

Installation Instructions

0 to 100% Downflow Dry Bulb Economizer

Packaged Cooling and Gas/Electric
12.5 to 25 Tons

Model Number:
FIAECON003*

Used With:
T/YS*180-300, W/D/GS*150-300

SAFETY WARNING

Only qualified personnel should install and service the equipment. The installation, starting up, and servicing of heating, ventilating, and air-conditioning equipment can be hazardous and requires specific knowledge and training. Improperly installed, adjusted or altered equipment by an unqualified person could result in death or serious injury. When working on the equipment, observe all precautions in the literature and on the tags, stickers, and labels that are attached to the equipment.

August 2022

ACC-SVN232A-EN

Introduction

Read this manual thoroughly before operating or servicing this unit.

Warnings, Cautions, and Notices

Safety advisories appear throughout this manual as required. Your personal safety and the proper operation of this machine depend upon the strict observance of these precautions.

The three types of advisories are defined as follows:

⚠ WARNING Indicates a potentially hazardous situation which, if not avoided, could result in death or serious injury.

⚠ CAUTION Indicates a potentially hazardous situation which, if not avoided, could result in minor or moderate injury. It could also be used to alert against unsafe practices.

NOTICE Indicates a situation that could result in equipment or property-damage only accidents.

Important Environmental Concerns

Scientific research has shown that certain man-made chemicals can affect the earth's naturally occurring stratospheric ozone layer when released to the atmosphere. In particular, several of the identified chemicals that may affect the ozone layer are refrigerants that contain Chlorine, Fluorine and Carbon (CFCs) and those containing Hydrogen, Chlorine, Fluorine and Carbon (HCFCs). Not all refrigerants containing these compounds have the same potential impact to the environment. Trane advocates the responsible handling of all refrigerants-including industry replacements for CFCs and HCFCs such as saturated or unsaturated HFCs and HCFCs.

Important Responsible Refrigerant Practices

Trane believes that responsible refrigerant practices are important to the environment, our customers, and the air conditioning industry. All technicians who handle refrigerants must be certified according to local rules. For the USA, the Federal Clean Air Act (Section 608) sets forth the requirements for handling, reclaiming, recovering and recycling of certain refrigerants and the equipment that is used in these service procedures. In addition, some states or municipalities may have additional requirements that must also be adhered to for responsible management of refrigerants. Know the applicable laws and follow them.

⚠ WARNING

Proper Field Wiring and Grounding Required!

Failure to follow code could result in death or serious injury.

All field wiring **MUST** be performed by qualified personnel. Improperly installed and grounded field wiring poses **FIRE** and **ELECTROCUTION** hazards. To avoid these hazards, you **MUST** follow requirements for field wiring installation and grounding as described in **NEC** and your local/state/national electrical codes.

⚠ WARNING

Personal Protective Equipment (PPE) Required!

Failure to wear proper PPE for the job being undertaken could result in death or serious injury. Technicians, in order to protect themselves from potential electrical, mechanical, and chemical hazards, **MUST** follow precautions in this manual and on the tags, stickers, and labels, as well as the instructions below:

- Before installing/servicing this unit, technicians **MUST** put on all PPE required for the work being undertaken (Examples; cut resistant gloves/sleeves, butyl gloves, safety glasses, hard hat/bump cap, fall protection, electrical PPE and arc flash clothing). **ALWAYS** refer to appropriate Safety Data Sheets (SDS) and OSHA guidelines for proper PPE.
- When working with or around hazardous chemicals, **ALWAYS** refer to the appropriate SDS and OSHA/ GHS (Global Harmonized System of Classification and Labeling of Chemicals) guidelines for information on allowable personal exposure levels, proper respiratory protection and handling instructions.
- If there is a risk of energized electrical contact, arc, or flash, technicians **MUST** put on all PPE in accordance with OSHA, NFPA 70E, or other country-specific requirements for arc flash protection, **PRIOR** to servicing the unit. **NEVER PERFORM ANY SWITCHING, DISCONNECTING, OR VOLTAGE TESTING WITHOUT PROPER ELECTRICAL PPE AND ARC FLASH CLOTHING. ENSURE ELECTRICAL METERS AND EQUIPMENT ARE PROPERLY RATED FOR INTENDED VOLTAGE.**

⚠ WARNING

Follow EHS Policies!

Failure to follow instructions below could result in death or serious injury.

- All Trane personnel must follow the company's Environmental, Health and Safety (EHS) policies when performing work such as hot work, electrical, fall protection, lockout/tagout, refrigerant handling, etc. Where local regulations are more stringent than these policies, those regulations supersede these policies.
- Non-Trane personnel should always follow local regulations.

Copyright

This document and the information in it are the property of Trane, and may not be used or reproduced in whole or in part without written permission. Trane reserves the right to revise this publication at any time, and to make changes to its content without obligation to notify any person of such revision or change.

Trademarks

All trademarks referenced in this document are the trademarks of their respective owners.

Table of Contents

General Information	5
Inspection	5
Parts List - Precedent™	5
Field Installed Option	5
Factory Installed Option	5
Installation - Precedent	6
Field Installed Option	6
Factory Installed Option (Field Set-Up)	8
Mist Eliminator Servicing	9
Minimum Position Setting	9
Dry Bulb Settings	10
Reference Enthalpy Settings	10
Wiring Connections	10

General Information

Inspection

1. Unpack all components of the kit.
2. Check carefully for shipping damage. If any damage is found, report it immediately, and file a claim against the transportation company.
3. Visually inspect the components for shipping damage as soon as possible after delivery, before it is stored. Concealed damage must be reported within 15 days.
4. If concealed damage is discovered, stop unpacking the shipment.

5. Do not remove damaged material from the receiving location. Take photos of the damage, if possible. The owner must provide reasonable evidence that the damage did not occur after delivery.
6. Notify the carrier's terminal of damage immediately by phone and by mail. Request an immediate joint inspection of the damage by the carrier and the consignee.

Note: Do not attempt to repair any damaged parts until the parts are inspected by the carrier's representative.

Parts List

Field Installed Option

Figure 1. Major economizer components

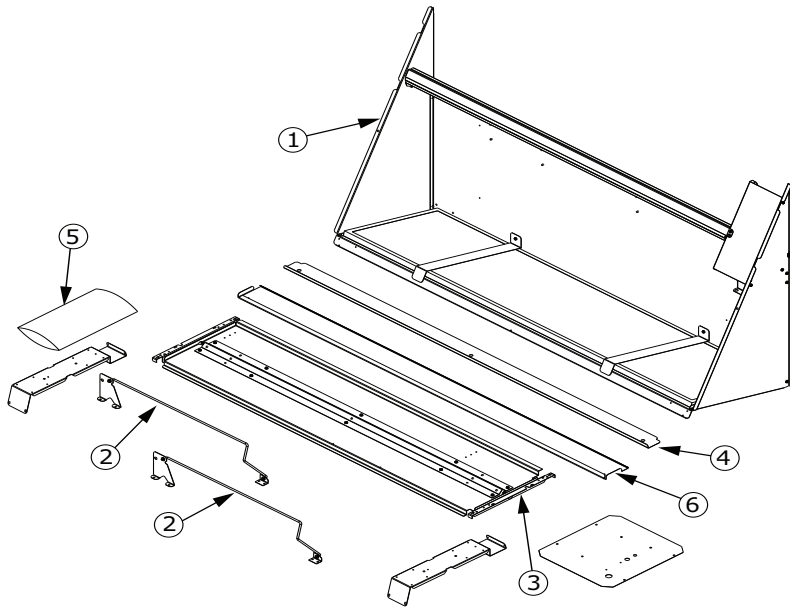

Item	Description	Qty
1	Outside air damper assembly	1
2	Connecting rod assembly	2
3	Return air damper assembly	1
4	Block-off	1
5	Plastic bag of miscellaneous parts	1
	Screws	
	Edge protector	1
	Installation Instructions manual	1
6	Rain diverter	1

Note: Verify all the parts are available for installation.

Factory Installed Option

Item	Description	Qty
1	Block-off	1
2	Plastic bag containing Screws	1

Installation

⚠ WARNING

Hazardous Service Procedures!

Failure to follow all precautions in this manual and on the tags, stickers, and labels could result in death or serious injury.

Technicians, in order to protect themselves from potential electrical, mechanical, and chemical hazards, **MUST** follow precautions in this manual and on the tags, stickers, and labels, as well as the following instructions: Unless specified otherwise, disconnect all electrical power including remote disconnect and discharge all energy storing devices such as capacitors before servicing. Follow proper lockout/tagout procedures to ensure the power can not be inadvertently energized. When necessary to work with live electrical components, have a qualified licensed electrician or other individual who has been trained in handling live electrical components perform these tasks.

Field Installed Option

⚠ WARNING

Hazardous Voltage w/Capacitors!

Failure to disconnect power and discharge capacitors before servicing could result in death or serious injury. Disconnect all electric power, including remote disconnects and discharge all motor start/run capacitors before servicing. Follow proper lockout/tagout procedures to ensure the power cannot be inadvertently energized. Verify with a CAT III or IV voltmeter rated per NFPA 70E that all capacitors have discharged.

1. Assemble connecting rods 4 to return air damper 3 by aligning holes 1 and 2, and attach rods using two screws as shown below.

Figure 2. Assemble connecting rods

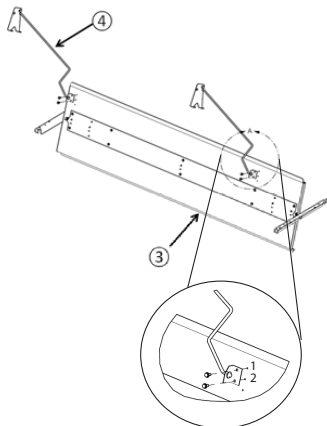

2. Remove the filter/fan compartment access panel and the unit end panel (evaporator end).

Figure 3. Remove panels

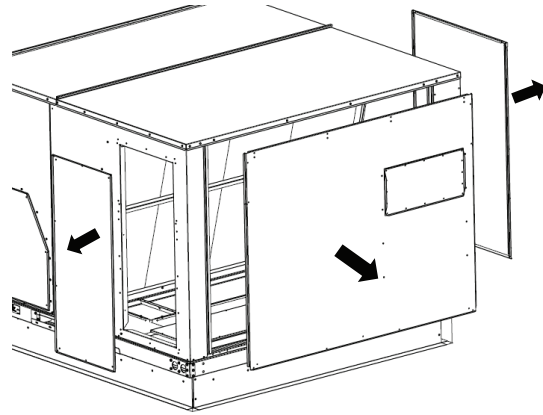

- a. Place the return air damper assembly into the return air opening as illustrated in Figure 4. Confirm damper is positioned with the sheet metal lip in the upward position.
- b. Attach the pivotal brackets to the unit using two screws per bracket.
- c. Raise the damper and rods into the vertical position. Position the connecting rods against the filter rack to prevent them from interfering with the economizer. See Figure 4.
- d. Confirm damper is positioned with sheet metal lip in the upward position as illustrated in following figure.

Figure 4. Install return air damper assembly

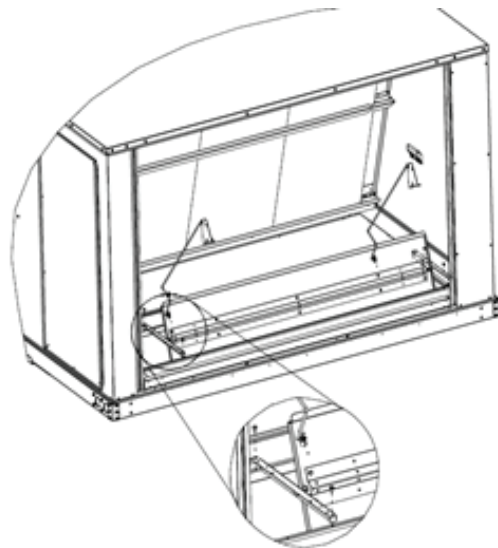

3. Block-off installation

- a. Attach block-off 5 to unit using four screws as illustrated in Figure 5.

The block-off is designed to close the opening created between the economizer and the base, when the economizer assembly is in its operating position.

Figure 5. Install block-off

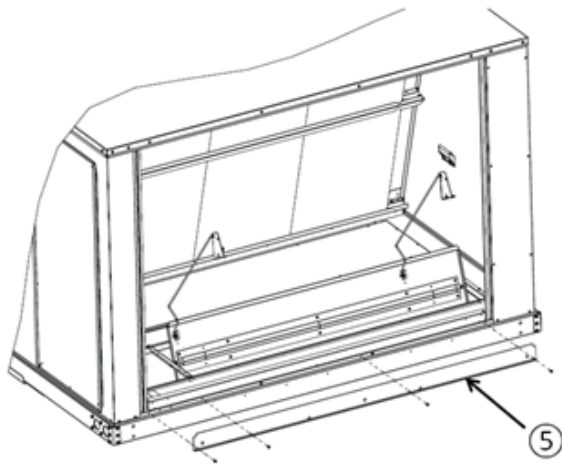

- b. Remove approximately 3-inch of gasket material from the bottom of each corner post to expose the holes used to attach the economizer assembly to the unit, as illustrated in Figure 6 detail "A".

Note: There are two holes, a (large) clearance hole and a (small) engagement hole. Their function will be discussed later.

Figure 6. Remove gasket material

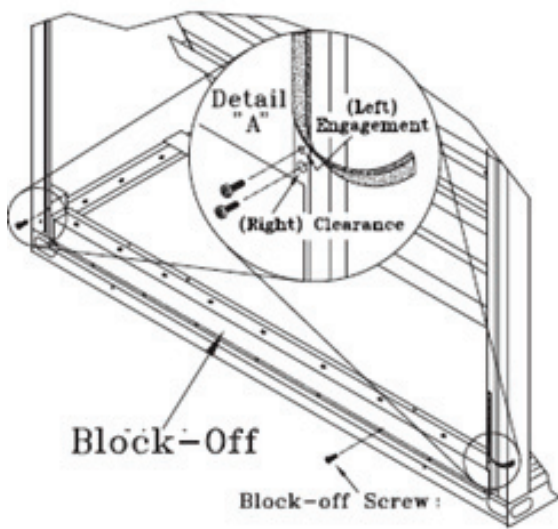

4. Economizer assembly installation

- a. Place tape (refer to "Parts List," p. 5) where shipping screws were removed.

- b. Place the economizer assembly into the opening with the back right flange, on the economizer, behind the corner post flange, as illustrated in following figure.

Figure 7. Install economizer assembly

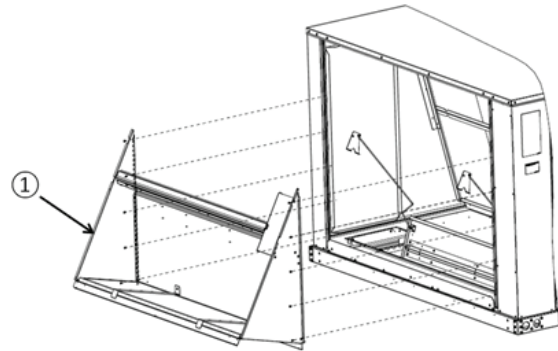

- c. Position the left side flange on the economizer in front of the corner post flange.
- d. With the screws provided, secure the bottom right hand side of the economizer assembly by inserting the screws through the clearance holes in the corner post and into the engagement holes in the economizer assembly. Refer to Figure 7.
- e. Secure the bottom left hand side of the economizer assembly by inserting the screws through the clearance holes in the economizer assembly and into the engagement holes of the corner post. Refer to Figure 7.
- f. Secure economizer using four screws on left side and 4 screws on right side as illustrated in Figure 7.
- g. Attach connecting rod bracket to outdoor damper blade using two screws on each side as illustrated in following figure, detail "B". Check for binding by slowly operating the dampers by hand.

Figure 8. Attach connecting rod bracket

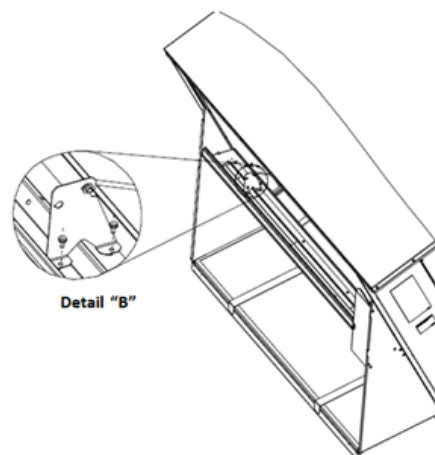

Installation

- Attach end panel back to unit.

Figure 9. Attach end panel

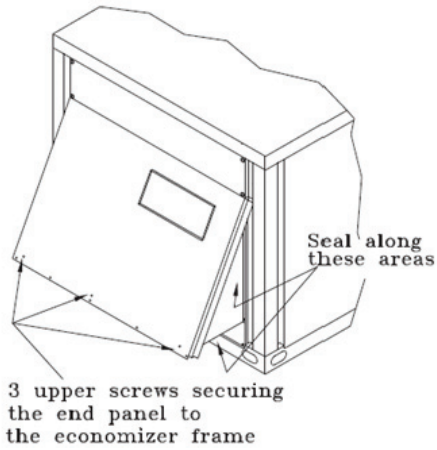

Factory Installed Option (Field Set-Up)

⚠ WARNING

Hazardous Voltage w/Capacitors!

Failure to disconnect power and discharge capacitors before servicing could result in death or serious injury. Disconnect all electric power, including remote disconnects and discharge all motor start/run capacitors before servicing. Follow proper lockout/tagout procedures to ensure the power cannot be inadvertently energized. Verify with a CAT III or IV voltmeter rated per NFPA 70E that all capacitors have discharged.

Each economizer ships inside the unit and requires partial assembling and setup in the field.

- Remove the filter/fan compartment access panel.
- Remove the lower screws in the end panel. See [Figure 11](#). Lay block-off angle aside for later installation.
- Remove and discard shipping bracket.

Figure 10. Remove filter access panel

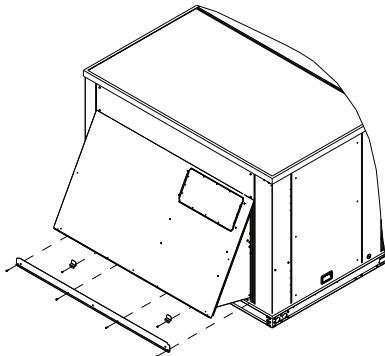
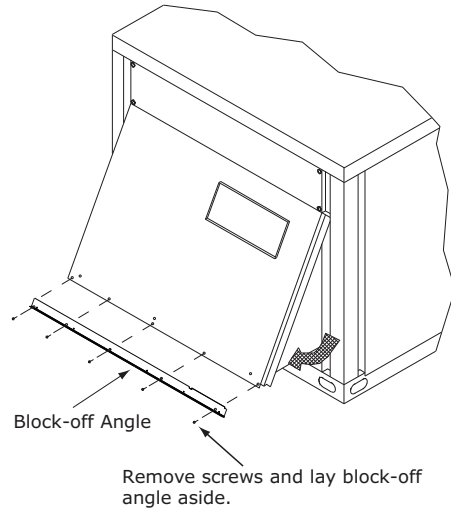
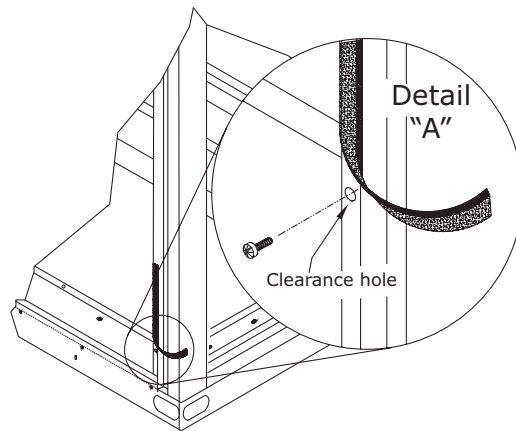

Figure 11. Pull economizer assembly outward



- Do not remove the screws in the upper row of the end panel.
- Grasp the bottom of the end panel and pull the economizer assembly outward into the operating position. See [Figure 11](#).
- Remove approximately 3-inch of gasket material from the bottom of each corner post to expose the holes used to attach the economizer assembly to the unit. See [Figure 12](#).
- With the screws provided, secure each side of the economizer assembly by inserting a screw through the clearance hole in the bottom of the corner post and into the engagement hole in the economizer assembly. Refer to following figure.

Figure 12. Remove gasket material



8. Install the block-off angle underneath the economizer. Refer to [Figure 13](#). The block-off angle is designed to close the opening created between the economizer and the base when the economizer assembly is in its operating position.
 - a. Holding the block-off angle with the holes at the bottom and the bottom angle outward, tilt the top forward and insert it into the opening between the economizer and the unit base.
 - b. Press the bottom of the block-off angle against the unit and line up the holes. Using the provided screws, secure it into place.
 - c. Apply sealant between block-off and base as shown below.

Figure 13. Block-off installation

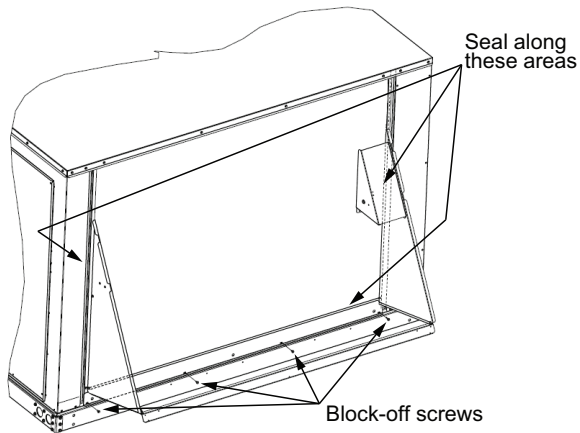

9. Attach filter and rear access panels.
10. Install rain diverter as shown in [Figure 14, p. 9](#) using 4 screws provided.

Figure 14. Rain diverter installation

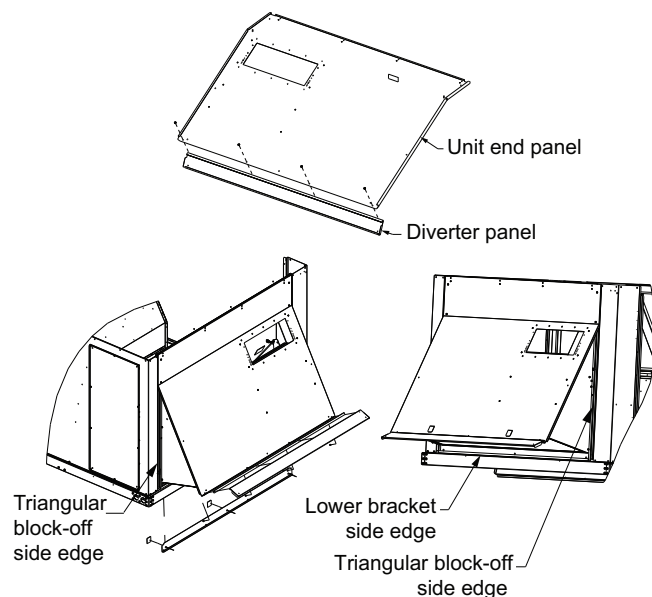

11. Using field supplied silicone sealant, seal all seams, cracks and gaps around the back panel and vertical edge of the hood panels.

Figure 15. Sealant application location (both sides)

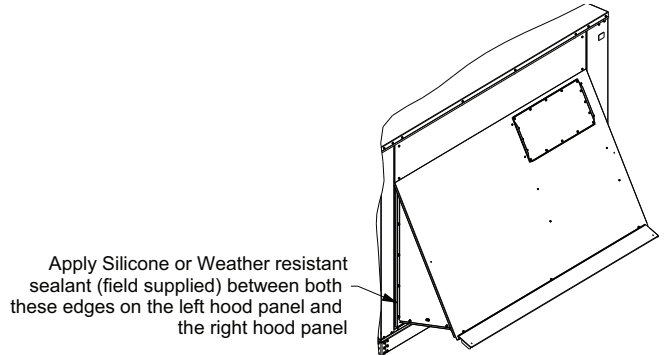

Mist Eliminator Servicing

1. Remove screws from end panel that secure it to the unit and economizer.
2. Set end panel aside.
3. Remove mist eliminator brackets.
4. Remove mist eliminators and clean.
5. Install and secure the mist eliminator brackets.
6. Install end panel and secure to unit and economizer.

Figure 16. Mist eliminator removal

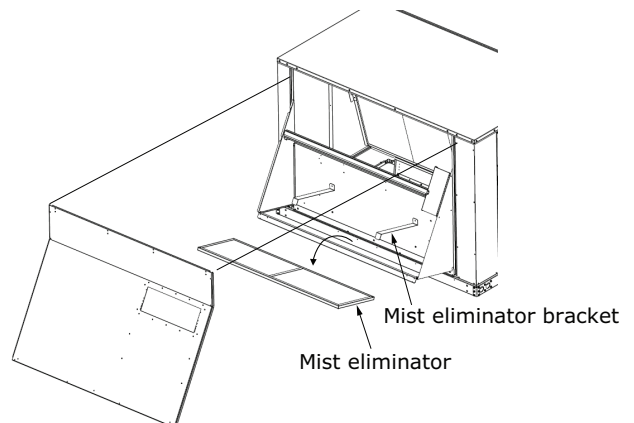

Installation

Minimum Position Setting

To adjust the minimum position setting and check out the economizer, the power must be connected.

1. Close the unit disconnect and place the zone sensor fan selector in the fan **ON** position and the heat/cool selector in the **OFF** position. This will place the damper in the minimum ventilation position.
2. To adjust the minimum position setting for the required ventilation air, use the Symbio™ service and installation mobile app or Symbio™ 700 on-board UI to adjust the economizer minimum position setpoint BAS in the fresh/return air settings menu. The damper will open to this setting each time the blower circuit is energized.

When adjusting minimum position, the damper may move to the new setting in several small steps. Once the damper has remained in position for 10 - 15

seconds without movement, it can be assumed it is at the new position.

3. Replace the filter access panel.

The damper will close when the blower circuit is de-energized.

Dry Bulb Settings

Standard economizer dry bulb changeover is field selectable and has a range of 50-140°F.

Reference Enthalpy Settings

Economizer enthalpy changeover is field selectable and has a range of 50-140°F. The default is 60°F. This selection can be made using the Symbio service and installation mobile app or Symbio™ 700 on-board UI.

Table 1. Precedent economizer control options

Control Option	Enable Conditions	Optional Sensors Required
Comparative Enthalpy	Outside Air Enthalpy < Return Air Enthalpy – Econ Enthalpy Offset AND Outside Air Temperature < Economizer Drybulb Setpoint – Econ DryBulb Offset	Outdoor Air Temperature Sensor Outdoor Air Humidity Sensor Return Air Temperature Sensor Return Air Humidity Sensor
Reference Enthalpy	Outside Air Enthalpy < Reference Enthalpy Setpoint – Econ Enthalpy Offset AND Outside Air Temperature < Economizer Drybulb Setpoint – Econ DryBulb Offset	Outdoor Air Temperature Sensor Outdoor Air Humidity Sensor
Dry Bulb	OA Temp < [Economizer Outdoor Air Enable Setpoint BAS - Economizer Dry Bulb Enable Offset]	Outdoor Air Temperature Sensor
Differential Dry Bulb	OA Temp < RA Temp - Economizer Dry Bulb Enable Offset - Economizer Dry Bulb Disable Return Air Offset	Outdoor Air Temperature Sensor Return Air Temperature Sensor

Wiring Connections

Refer to main unit schematic sheet 6 for electrical connections to Fresh air module located in return section control box, See [Figure 17, p. 10](#).

Figure 17. Fresh air options module location



Fresh air options module access (B and C cabinet)

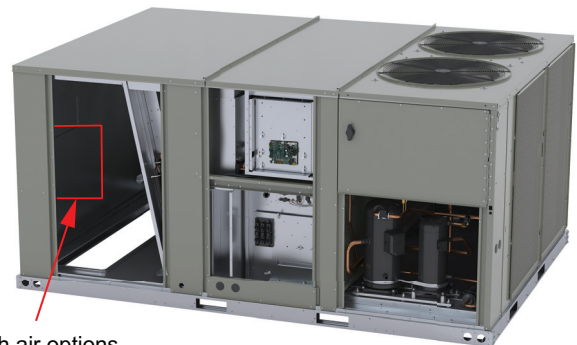

Fresh air options module access (D cabinet)

After installation is complete, the Symbio™ 700 UC configuration will need to be updated to enable this installed feature. Refer to Symbio Applications Guide.

Trane and American Standard create comfortable, energy efficient indoor environments for commercial and residential applications. For more information, please visit trane.com or americanstandardair.com.

Trane and American Standard have a policy of continuous product and product data improvement and reserve the right to change design and specifications without notice. We are committed to using environmentally conscious print practices.