



TRANE™

Tracker™

Building Management System

Installation Guide

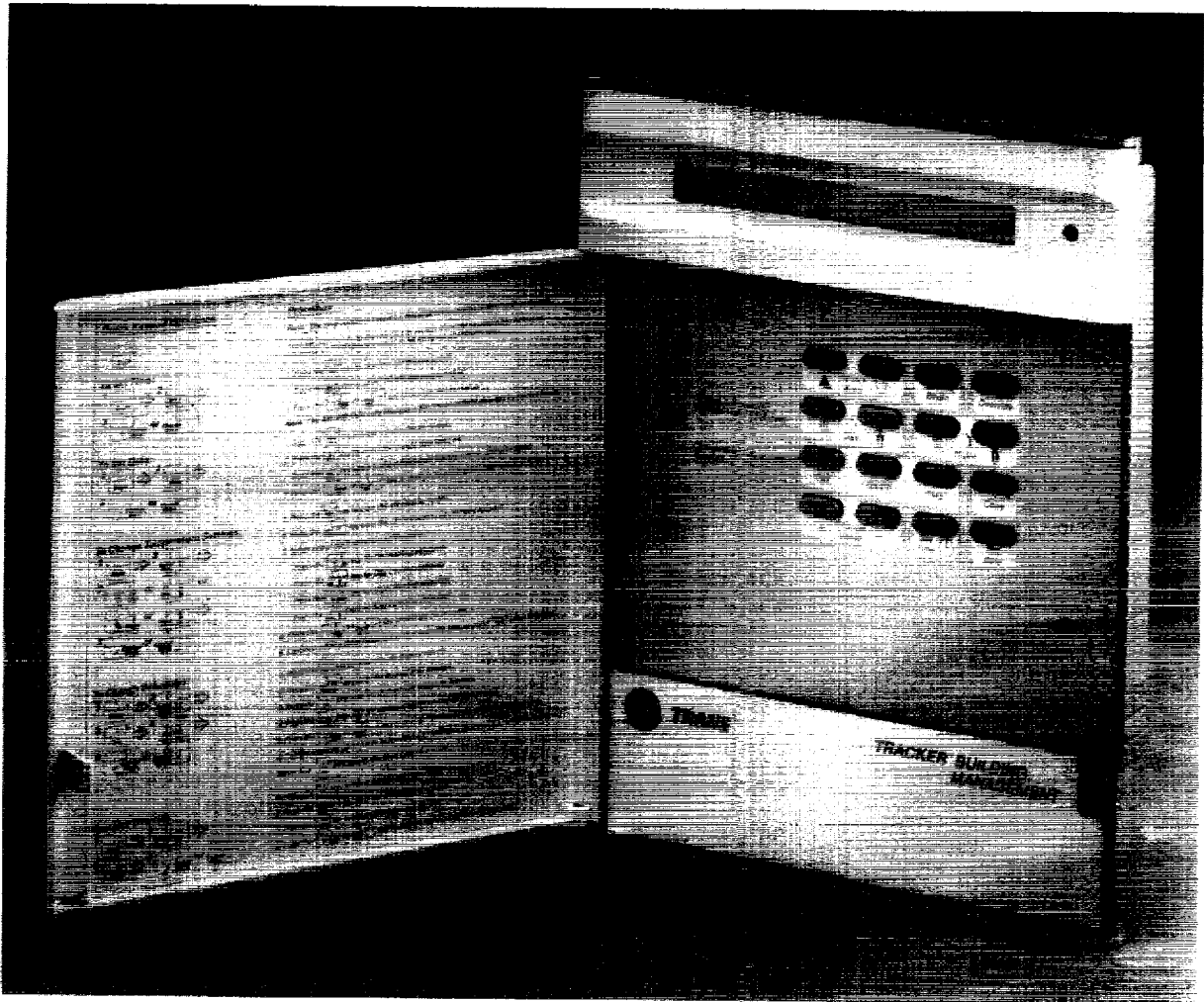

Software Version 6.0

Includes Trackers used with:

- Thermostat Control Modules™
- Voyager™ Rooftop Units
- VariTrac™ II Central Control Panels

Table of Contents

About This Manual	1	Input Wiring	19
FCC Information	3	Input Wiring Requirements	19
Specifications	5	Outdoor Air Temperature Sensor	
Power Requirements	5	– Analog Input Wiring	19
Operating Environment	5	Binary Input Wiring	21
Storage Environment	5	Edit Terminal (RS-232) Interface	21
Cabinet	5	Settings on External Devices	23
Mounting	5	Modem Interface for Edit Terminal	23
Dimensions	5	Setup Requirements for Modem at Remote PC	24
Weight	5	Tracker Installation Checkout	24
Communication Link Wiring	5	ON/OFF Switch	24
Analog Temperature Input	5	Status LEDs	24
Binary Input	5	Installation Checklist	25
U.L. Approval	5	Troubleshooting	27
Memory Backup	5	ICS Communication Link	27
General Information	7	Cable for Communication Link	28
Unit Description	7	Hardware for Troubleshooting	28
Communication Link	9	Index	Index-1
Shipment	9		
Storage	9		
Installation	11		
Unit Mounting	11		
Location Within Building	11		
Operating Environment	11		
Clearances	11		
Mounting	11		
AC Power Wiring	13		
Power Supply	13		
AC Power Connections	13		
AC Power Checkout	13		
Communication Link Wiring	14		
DIP Switch Settings	17		
DIP Switch Settings 6-8 on VariTrac II Central			
Control Panel	19		

Since The Trane Company has a policy of continuous product improvement, it reserves the right to change specifications and design without notice. The equipment referred to in this booklet should be installed and serviced by qualified, experienced technicians.

About This Manual

Contents

This manual describes the steps required to properly install, set up, and operate the Tracker building management system. Sections in this manual are as follows:

- **FCC Information:** Information about FCC approval and possible radio and telephone interference.
- **Specifications:** Technical specifications for the Tracker unit.
- **General Information:** A brief description of the Tracker building management system, including an illustration of a typical Tracker application.
- **Installation:** Detailed installation information such as mounting, wiring, and switch settings. Includes an Installation Checklist.
- **Troubleshooting:** General troubleshooting guidelines for common problems.

Tracker Naming Conventions

The use of the name *Tracker* in this manual implies Tracker Stat 16 and Tracker Stat 7. In any case where information is unique to one model, the model will be specified.

Warnings and Cautions

Where appropriate, cautionary statements are used to signal procedures or conditions that require particular attention. A **WARNING** alerts installing contractors and service personnel to potential hazards that could result in personal injury or death. A **CAUTION** alerts the user to the risk of equipment damage. Your personal safety and the proper operation of these systems depend upon the strict observance of these precautions.

Related Literature

- Tracker Operator's Guide
- Tracker Quick Reference
- Thermostat Control Module Installation/Operation/Maintenance
- VariTrac II Central Control Panel Installation Guide
- VariTrac II Central Control Panel Operator's Guide

Software Change History

A chronological history of the changes made to Tracker software is in the Tracker Operator's Guide.

FCC Information

Tracker Internal Modem (50100745)

The Tracker internal modem is used to communicate with an external edit terminal. The following is FCC information that applies to the internal modem.

FCC Registration

FCC68: 1ZWUSA-65439-AL-E
Ringer Equivalence Number: 0.8B
FCC15: Class A

The Tracker internal modem complies with Part 68 of the FCC Rules. On the modem circuit board is a label that contains the FCC Registration Number and Ringer Equivalence Number (REN) for the modem.

Telephone Company

The telephone company may request the telephone number or numbers to which the modem is connected and the FCC information listed on the label on the modem circuit board. If the telephone company has any questions, ask them to call The Trane Company Technical Service Department at **1-800-TRACER1** (1-800-872-2371).

Do not use the modem on coin or party telephone lines. If the modem malfunctions, it may affect the telephone lines. In this case, disconnect the modem telephone line until the problem is corrected.

Tracker Radio and Television Interference

The Tracker generates, uses, and can radiate radio frequency energy and if not installed and used in accordance with the instruction manual, may cause interference to radio and television reception. The Tracker has been tested and found to comply with the limits for a Class A computing device in accordance with the specifications in Subpart J of Part 15 of FCC rules, which are designed to provide reasonable protection against such interference in a commercial installation.

There is no guarantee that interference will not occur in a particular installation. If the Tracker does cause interference, consult a radio or television technician for suggestions to correct the problem. Also, the booklet *How to Identify and Resolve Radio-TV Interference Problems* is available from the U.S. Government Printing Office, Washington, D.C. 20402. Order stock #004-000-00345-4.

Specifications

Power Requirements	20-30 VAC, 60 Hz, 1 Ph 20 VA Minimum Class 2 Transformer Required
Operating Environment	32 to 120° F 10 to 90% relative humidity, non-condensing
Storage Environment	-40 to 140° F 10 to 90% relative humidity, non-condensing
Cabinet	NEMA 1 Enclosure
Mounting	Mount directly on wall surface or mount on recessed 4" x 4" conduit box.
Dimensions	12" high x 9-3/4" wide x 2-3/4" deep
Weight	4 pounds
Communication Link Wiring	Communication link wiring must be 18 AWG twisted, shielded pair wire. Each conductor must be stranded tinned copper. The maximum total wire length is 5,000 feet. Wire must meet the specifications of Trane wire ordering number 400-20-28. See Figure 1 for specifications.
Analog Temperature Input	Thermistor device, range -30 to 150° F
Binary Input	Voltage Provided: 10 - 14 VDC Current Provided: 10 - 14 mA
U.L. Approval	The Tracker is U.L. approved.
Memory Backup	Upon a power loss, all operator-edited data stored in the Tracker, such as area names, setpoints, and Time of Day schedules, will be maintained permanently. System time and date will be maintained for a minimum of 14 days at a temperature below 104° F (40° C).

Figure 1
Communication Link Wire Specifications
400-20-28 - 18 AWG Plenum-Rated Shielded Pair Cable

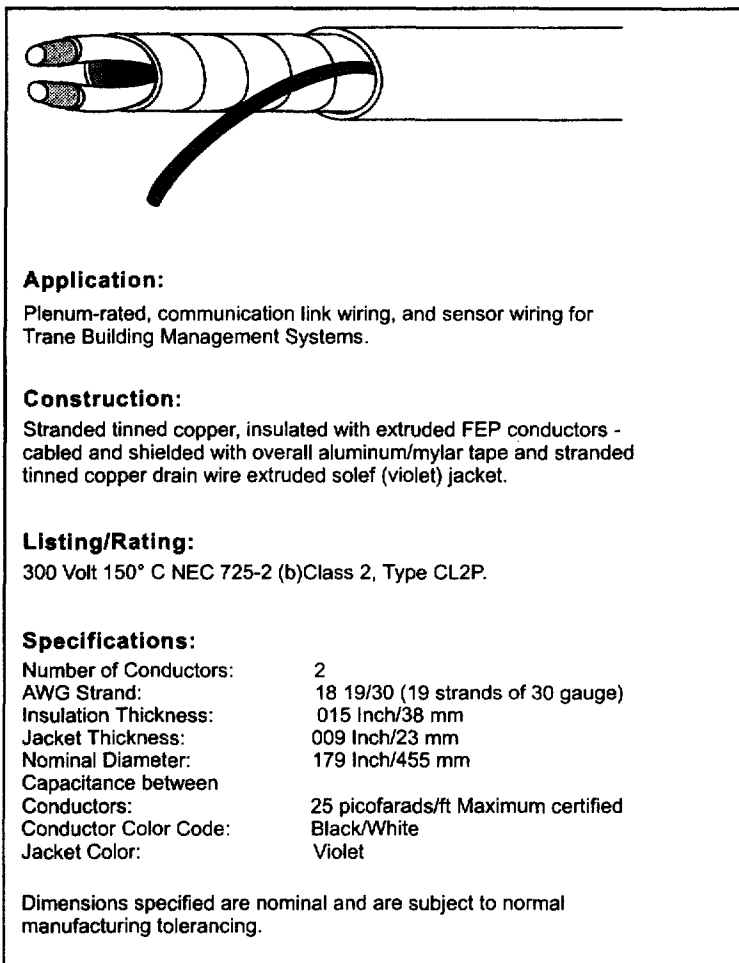

General Information

Unit Description

The Tracker is a building management system designed to provide centralized access (status and setup) to the following Trane devices:

- Thermostat Control Module (TCM: thermostat 2H2C, heat pump, and slave)
- Voyager Rooftop Unit
- VariTrac II Central Control Panel and zone damper Unit Control Module (UCM)

The two models of the Tracker panel are the Stat 7 and the Stat 16. The Tracker Stat 7 is a smaller version, meant to communicate with a limited number of units. The Tracker Stat 16 includes all Tracker Stat 7 capabilities, but is able to communicate to a greater number of units, and is additionally capable of Demand Limiting.

The Tracker provides input monitoring and output control based on distributed control through the Thermostat Control Modules, Voyager Rooftops, and VariTrac II Central Control Panels. The Tracker provides one thermistor input for an outdoor air temperature sensor. The Stat 16 model also provides one binary input for a pulse meter.

The Tracker maintains time and date, and provides time of day (TOD) scheduling for the connected devices. Also, Tracker provides setpoint control for day/night heating and cooling temperatures of the connected devices.

The Tracker ships with a default set of pre-programmed comfort operating parameters, and automatically assigns default point names to undefined devices with which it is communicating. The Tracker also automatically names binary outputs for slave TCMs. This feature minimizes the amount of operator editing required to start up a system and serves as an example for customizing names.

The operator interface with the Tracker includes both a 16-key front panel keypad with a two line by 40 character display, and a full access RS-232 edit terminal communications port that is used with a CRT terminal. A second communication port on the modem board can be used for remote communications over phone lines. This optional internal modem is a separate circuit board inside the Tracker panel.

Additional building control features of the Tracker include the following:

- Alarming of communication failures, high and low temperature conditions, and system/unit diagnostics which can be viewed at the front panel display, the edit terminal port using a CRT terminal, or remotely via the optional internal modem.
- Trend logging to record space temperatures and other data at fixed intervals.
- A slave Thermostat Control Module whose outputs can be operator controlled and assigned to TOD schedules, and whose inputs can monitor temperatures and status values.
- Optimal start.
- Holiday and exception scheduling.
- Four-character password security protection.
- Demand Limiting (Tracker Stat 16 model only).

Figure 2 illustrates a typical Tracker application. Figure 3 shows the major Tracker terminator card components.

Figure 2
Typical Tracker Application

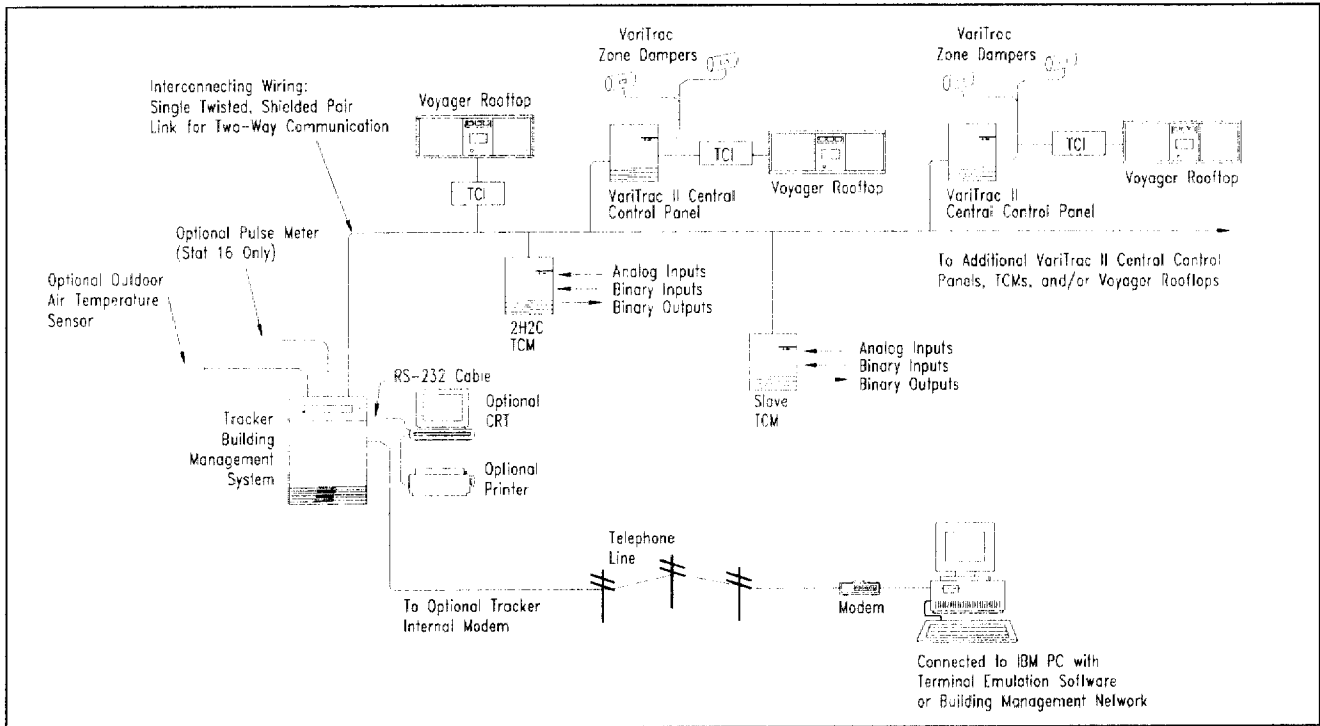
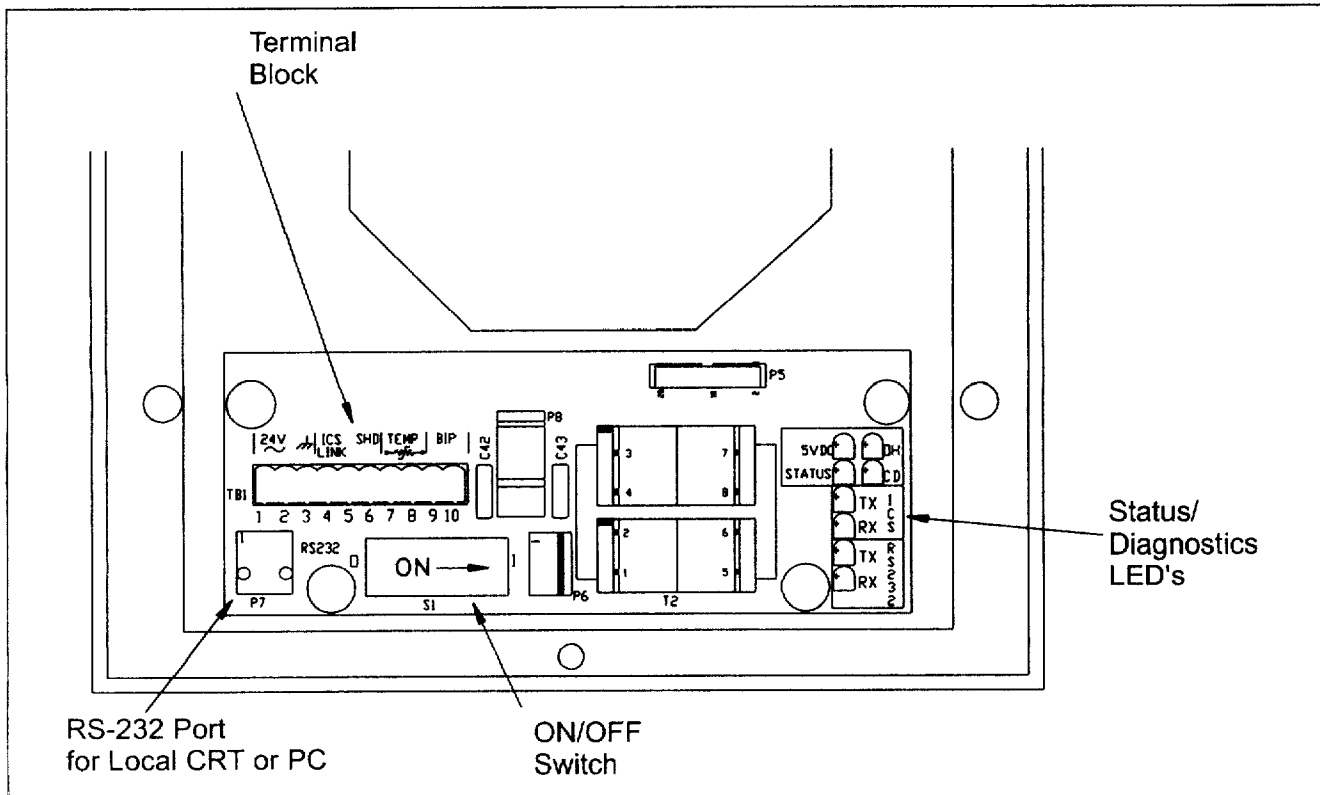

Figure 3
Tracker Terminator Card Component Layout



Communication Link

The Tracker has a serial communication link to allow it to communicate with Thermostat Control Modules, Voyager Rooftop Units and VariTrac II Central Control Panels. Table 1 lists the total device counts for each Tracker model.

Table 1
Device Counts for Tracker Models

Tracker Model	Number of Devices Allowed				
	TCM	Voyager Rooftop	VariTrac I Comfort Manager	VariTrac II Central Control Panel	Slave TCM
Stat 16	12	12	0	8	2
Stat 7	7	7	0	4	2

Note: Total device count on a Tracker Stat 16 may not exceed 16 plus 2 Slave TCMS. Total device count on a Tracker Stat 7 may not exceed 7 plus 2 Slave TCMS.

Shipment

The Tracker and service literature are shipped in the same package. When unpacking, make sure that the literature is not lost or discarded with the packing material.

Visually inspect the Tracker for obvious defects or damage. All components are thoroughly inspected before leaving the factory. Any claims for damage incurred in shipping should be filed with the carrier.

Storage

If the unit is to be stored for a period of time, the storage temperature should be -40° to 140° F. The relative humidity of the storage location should be 10 to 90 percent, non-condensing. A controlled indoor environment is recommended for storage.

Installation

Unit Mounting

Location Within Building

Mount the Tracker with the LCD at eye level to allow for easy on-site adjustments by building personnel. If possible, locate the Tracker near the controlled equipment to reduce wiring cost.

Operating Environment

The Tracker is designed for indoor use only. It should be located in a dust-free and corrosive-free environment, within a range of 32° to 120° F, and 10 to 90% humidity (non-condensing).

Clearances

The Tracker can be mounted on any vertical flat surface. The Tracker panel is approximately 12 inches high, 9-3/4 inches wide, and 2-3/4 inches deep (see Figure 4). With the front cover open, the installer has access to the front, top, and bottom panels.

When mounted, the Tracker should be easily accessible for making wiring connections and for servicing. Provide two inches of clearance on the left and right sides, and sufficient clearance above the unit to make conduit connections. At least 24 inches should be available in front of the unit for making wiring connections and performing maintenance.

Mounting

1. Remove the Tracker panel from the shipping carton.
2. Remove the screw at the bottom right corner (see Figure 5) and open the cover.
3. Remove the two screws on the right side of the faceplate. Swing open the faceplate.
4. Mount the enclosure to the wall. Three 3/16" holes are provided for mounting; use #8 mounting screws. Use the enclosed mounting template for marking and drilling mounting holes. As an alternate mounting method, a 4" x 4" knockout is provided for mounting the Tracker to a 4" x 4" recessed metal conduit box; use two #8 mounting screws. Figure 4 shows the Tracker mounting dimensions and the recommended mounting height. The unit weighs approximately four pounds.

CAUTION: *To avoid damaging the circuit board, do not use the knockout at the bottom of the panel. A warning sticker is attached to the bottom knockout. This sticker can be removed, and residue can be cleaned off with rubbing alcohol.*

5. Complete the wiring to the enclosure:
 - 24 VAC power
 - ICS communication link

Refer to the following sections on *AC Power Wiring* on page 13 and *Communication Link Wiring* on page 14.

6. Turn on the power switch. Refer to Figure 3.
7. Close the faceplate and tighten the two screws to secure.
8. Close the front cover. For additional local security, reinstall the screw at the bottom right corner. See Figure 5.

Figure 4
Dimensions for Tracker Enclosure

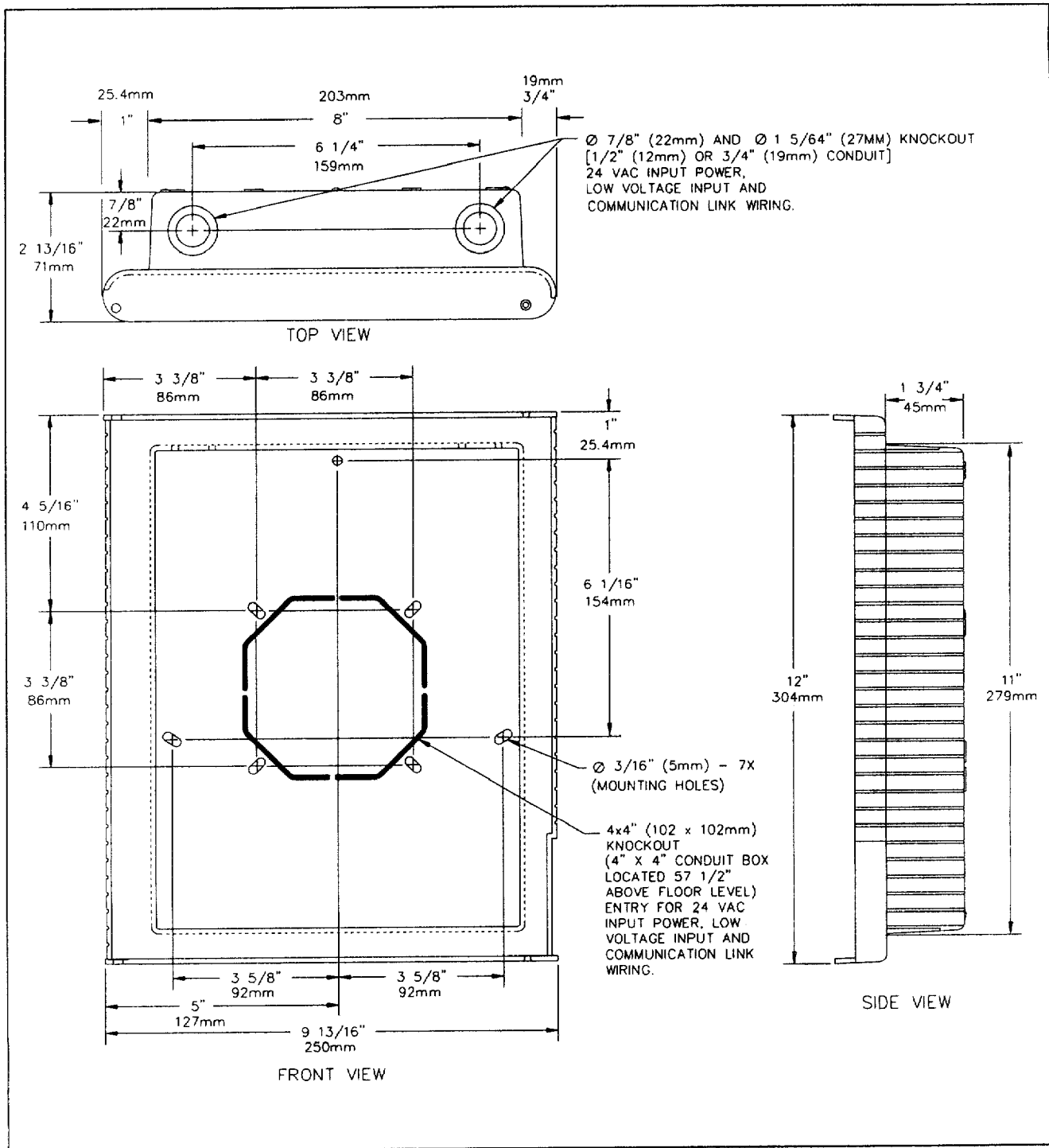
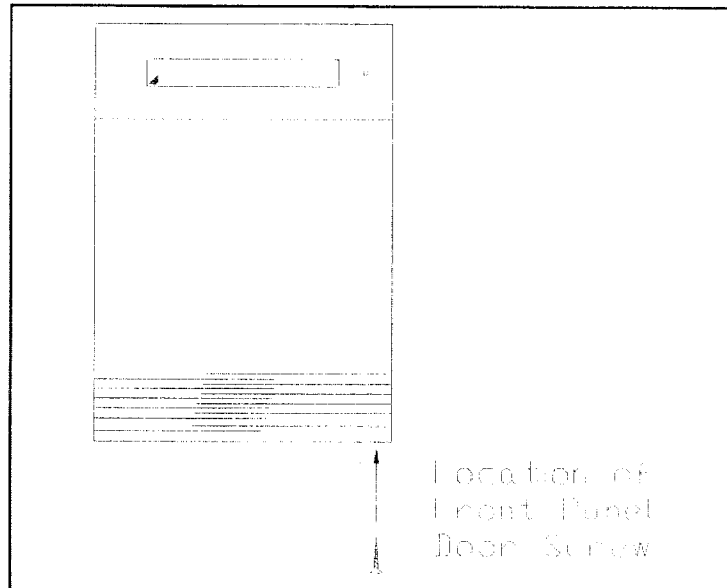

Figure 5
Location of Front Panel Door Screw



AC Power Wiring

Power Supply

A dedicated 24 VAC, 20 VA class 2 transformer is required to power the Tracker.

CAUTION: *The 24 VAC power supply must not be used to power any devices other than the Tracker. This could result in malfunction of the Tracker due to electrical noise.*

The Tracker requires 3-wire service with a nominal voltage of 24 VAC and a utilization range of 20 to 30 VAC. We recommend you use 16 AWG wire and metal conduit. All wiring must comply with the National Electrical Code and local codes.

WARNING: *To prevent injury or death from electrical shock, disconnect power external to the Tracker before making power connections.*

AC Power Connections

The 24 VAC line can enter the Tracker cabinet through the 4" x 4" knockout or through the knockouts in the top of the panel.

CAUTION: *To avoid damaging the circuit board, do not use the knockout at the bottom of the panel. A warning sticker is attached to the bottom knockout. Remove the sticker and clean off the residue with rubbing alcohol.*

Figure 4 shows the 24 VAC conduit entry holes. Connect the 24 VAC line to the unit at TB1, located on the terminator card inside the Tracker, as shown in Figure 3. Connect the 24 VAC wires to TB1-1 and TB1-2 and connect the ground wire from the circuit breaker panel ground to TB1-3. Use copper conductors only.

CAUTION: *Do not run AC power wires in the same conduit or wire bundle with any input/output or communication link wires. This may cause the Tracker to malfunction due to electrical noise.*

AC Power Checkout

1. After the 24 VAC connections have been made at TB1, apply AC power by closing the circuit breaker for the class 2 transformer.

2. Measure the voltages at TB1. The voltage between TB1-1 and TB1-2 should be 20 to 30 VAC.

WARNING: *When measurements must be made with the power on, use care to prevent injury or death from electrical shock.*

Communication Link Wiring

The Tracker communication link (TB1-4, 5, and 6) is for communication with Thermostat Control Modules, Voyager Rooftop Units and VariTrac II Central Control Panels. Field wiring for the communication link must meet the following requirements.

1. All wiring must be in accordance with the National Electrical Code and local codes.
2. Communication link wiring must be 18 AWG twisted, shielded pair wire (meets or exceeds specifications for Trane ordering number 400-20-28). Refer to Figure 1.
3. At the Tracker, the communication link wires must be connected to Terminals TB1-4 and TB1-5. Refer to Figure 7. **There is no polarity requirement for this connection.**
4. At the Tracker, connect the shield on the communication link wiring to TB1-6. At each connected ICS device, the shield should be spliced with the shield from the next section of communication link wiring and taped to prevent any contact between the shield and ground. At the end of the link, the shield should be cut and taped back.
5. The maximum total wire length is 5,000 feet for the communication link (Refer to Figure 1).
6. The communication link wiring cannot pass between buildings.
7. Units on the communication link can be connected in a “daisy chain” configuration. The daisy chain configuration is preferred over other wiring configurations, such as the star configuration, because it is easier to solve communication problems by isolating portions of the communication link. See Figure 6 for an example of a daisy chain configuration.

Note: If the wire length on a daisy chain configuration exceeds 2,500 feet, install a 100-ohm termination resistor at the far end of the communication link.

The termination resistor is wired across the link (example: from the black wire to the white wire).

Do not connect the termination resistor to ground.

If the wire length is less than 800 feet, install a 300-ohm (or 270 to 330-ohm) termination resistor at the far end of the communication link. If you use the star configuration, you may need to install a 300-ohm (or 270 to 330-ohm) termination resistor at the end of each branch. Fewer branches reduce the chance of having communication problems.

8. Refer to the appropriate installation manual for the connected ICS equipment for the communication link terminator connections.
9. Each Voyager Rooftop requires a Trane Communications Interface (TCI) board for connection to the Tracker communication link. If a Voyager Rooftop is to be controlled by a VariTrac II Central Control Panel, a TCI also is required. See Figure 2.

CAUTION: Do not run communication link wiring in the same conduit or wire bundle with AC power wires. This may cause the Tracker to malfunction due to electrical noise.

Figure 6
Daisy Chain Configuration for Communication Link Wiring

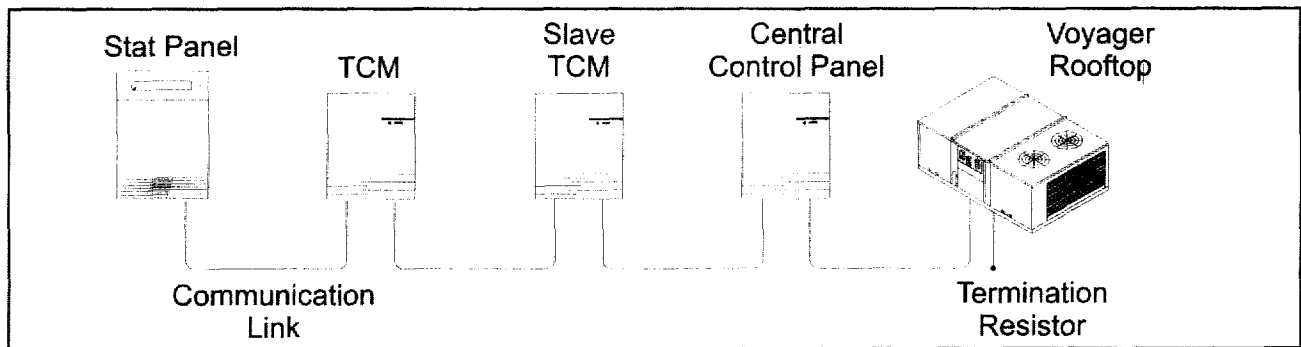
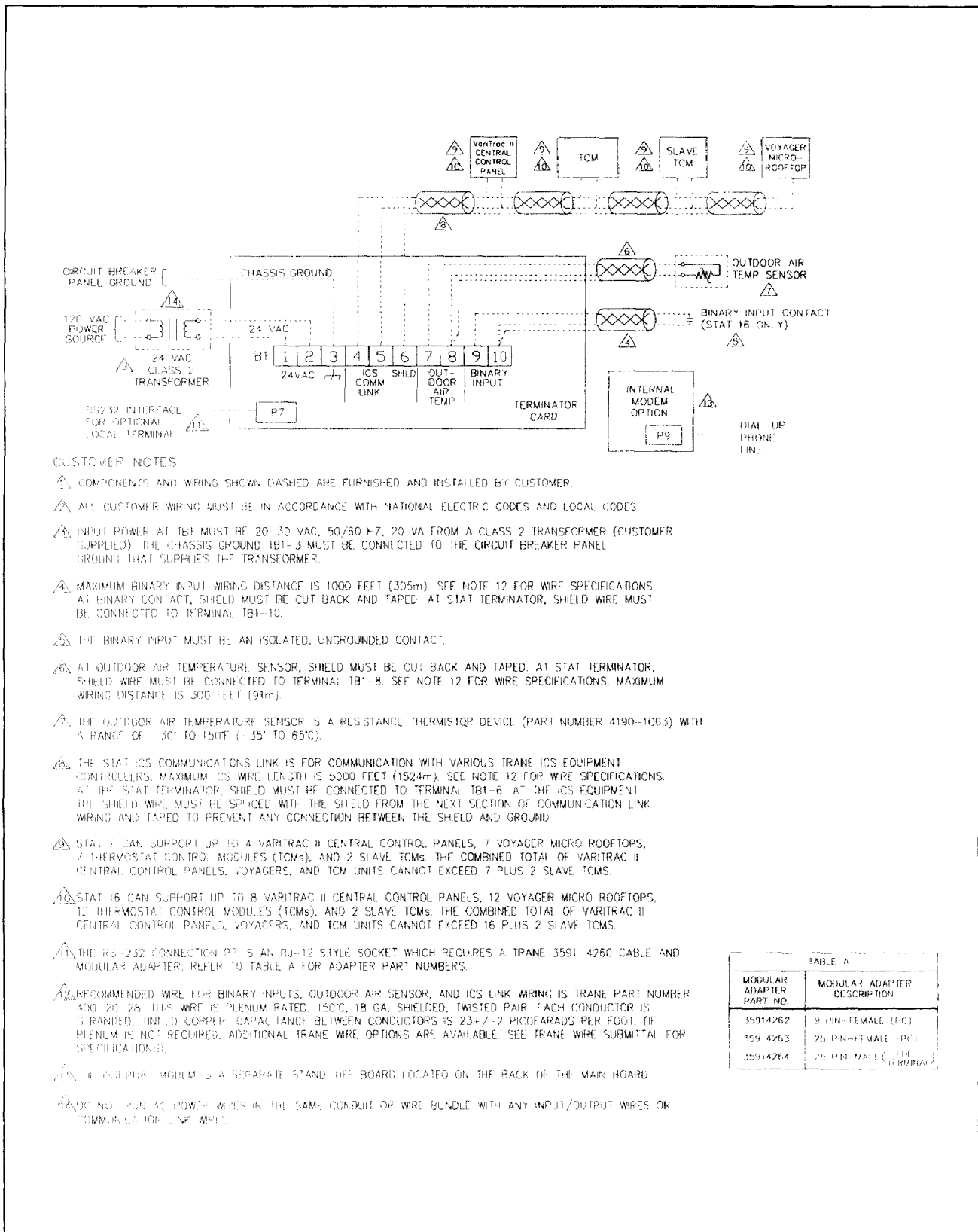

Figure 7
Tracker Field Wiring Connections



CUSTOMER NOTES

- ⚠ COMPONENTS AND WIRING SHOWN DASHED ARE FURNISHED AND INSTALLED BY CUSTOMER.
- ⚠ ALL CUSTOMER WIRING MUST BE IN ACCORDANCE WITH NATIONAL ELECTRIC CODES AND LOCAL CODES.
- ⚠ INPUT POWER AT T81 MUST BE 20-30 VAC, 50/60 HZ, 20 VA FROM A CLASS 2 TRANSFORMER (CUSTOMER SUPPLIED). THE CHASSIS GROUND T81-3 MUST BE CONNECTED TO THE CIRCUIT BREAKER PANEL GROUND THAT SUPPLIES THE TRANSFORMER.
- ⚠ MAXIMUM BINARY INPUT WIRING DISTANCE IS 1000 FEET (305m). SEE NOTE 12 FOR WIRE SPECIFICATIONS. AT BINARY CONTACT, SHIELD MUST BE CUT BACK AND TAPED. AT STAT TERMINATOR, SHIELD WIRE MUST BE CONNECTED TO TERMINAL T81-10.
- ⚠ THE BINARY INPUT MUST BE AN ISOLATED, UNGROUNDED CONTACT.
- ⚠ AT OUTDOOR AIR TEMPERATURE SENSOR, SHIELD MUST BE CUT BACK AND TAPED. AT STAT TERMINATOR, SHIELD WIRE MUST BE CONNECTED TO TERMINAL T81-8. SEE NOTE 12 FOR WIRE SPECIFICATIONS. MAXIMUM WIRING DISTANCE IS 300 FEET (91m).
- ⚠ THE OUTDOOR AIR TEMPERATURE SENSOR IS A RESISTANCE THERMISTOR DEVICE (PART NUMBER 4190-1063) WITH A RANGE OF -30° TO 150°F (-35° TO 65°C).
- ⚠ THE STAT ICS COMMUNICATIONS LINK IS FOR COMMUNICATION WITH VARIOUS TRANE ICS EQUIPMENT CONTROLLERS. MAXIMUM ICS WIRE LENGTH IS 5000 FEET (1524m). SEE NOTE 12 FOR WIRE SPECIFICATIONS. AT THE STAT TERMINATOR, SHIELD MUST BE CONNECTED TO TERMINAL T81-6. AT THE ICS EQUIPMENT THE SHIELD WIRE MUST BE SPLICED WITH THE SHIELD FROM THE NEXT SECTION OF COMMUNICATION LINK WIRING AND TAPED TO PREVENT ANY CONNECTION BETWEEN THE SHIELD AND GROUND.
- ⚠ STAT 7 CAN SUPPORT UP TO 4 VARITRAC II CENTRAL CONTROL PANELS, 7 VOYAGER MICRO ROOFTOPS, 7 THERMOSTAT CONTROL MODULES (TCMs), AND 2 SLAVE TCMs. THE COMBINED TOTAL OF VARITRAC II CENTRAL CONTROL PANELS, VOYAGERS, AND TCM UNITS CANNOT EXCEED 7 PLUS 2 SLAVE TCMs.
- ⚠ STAT 16 CAN SUPPORT UP TO 8 VARITRAC II CENTRAL CONTROL PANELS, 12 VOYAGER MICRO ROOFTOPS, 12 THERMOSTAT CONTROL MODULES (TCMs), AND 2 SLAVE TCMs. THE COMBINED TOTAL OF VARITRAC II CENTRAL CONTROL PANELS, VOYAGERS, AND TCM UNITS CANNOT EXCEED 16 PLUS 2 SLAVE TCMs.
- ⚠ THE RS-232 CONNECTION P7 IS AN RJ-12 STYLE SOCKET WHICH REQUIRES A TRANE 3591-4260 CABLE AND MODULAR ADAPTER. REFER TO TABLE A FOR ADAPTER PART NUMBERS.
- ⚠ RECOMMENDED WIRE FOR BINARY INPUTS, OUTDOOR AIR SENSOR, AND ICS LINK WIRING IS TRANE PART NUMBER 400-20-28. THIS WIRE IS PLENUM RATED, 150°C, 18 GA., SHIELDED, TWISTED PAIR. EACH CONDUCTOR IS STRANDED, TINNED COPPER. CAPACITANCE BETWEEN CONDUCTORS IS 23+/ -2 PICOFARADS PER FOOT. (IF PLENUM IS NOT REQUIRED, ADDITIONAL TRANE WIRE OPTIONS ARE AVAILABLE. SEE TRANE WIRE SUBMITTAL FOR SPECIFICATIONS).
- ⚠ IF INTERNAL MODEM IS A SEPARATE STAND OFF BOARD LOCATED ON THE BACK OF THE MAIN BOARD.
- ⚠ DO NOT RUN AC POWER WIRES IN THE SAME CONDUIT OR WIRE BUNDLE WITH ANY INPUT/OUTPUT WIRES OR COMMUNICATION LINK WIRES.

TABLE A	
MODULAR ADAPTER PART NO.	MODULAR ADAPTER DESCRIPTION
35914262	9 PIN-FEMALE (FC)
35914263	25 PIN-FEMALE (FC)
35914264	25 PIN-MALE (TERMINAL)

DIP Switch Settings

Each device connected to the Tracker must have its DIP switch set to a specific address. No two devices (of the same type) can have the same address. Tables 2, 5, 4, and 7 list the address settings for units that can be connected to a Tracker.

In addition to setting the address, the program option must be set for each TCM. Table 6 lists the DIP switch settings for TCM program selections.

Table 2
DIP Switch Settings (on TCI) for Voyager Rooftop Addresses

Voyager Number	DIP Switch Settings					
	SW1-1	SW1-2	SW1-3	SW1-4	SW1-5	SW1-6
01	Off	Off	Off	Off	Off	Off
02	Off	Off	Off	Off	Off	ON
03	Off	Off	Off	Off	ON	Off
04	Off	Off	Off	Off	ON	ON
05	Off	Off	Off	ON	Off	Off
06	Off	Off	Off	ON	Off	ON
07	Off	Off	Off	ON	ON	Off
The following are used for the Stat 16 model only:						
08	Off	Off	Off	ON	ON	ON
09	Off	Off	ON	Off	Off	Off
10	Off	Off	ON	Off	Off	ON
11	Off	Off	ON	Off	ON	Off
12	Off	Off	ON	Off	ON	ON

Note: DIP Switch 1 should be set to ON if using a high temperature limit switch on TB2-1,2 on the TCI.

Table 3
DIP Switch Settings (on TCI) for VariTrac II Central Control Panel

VariTrac II Central Control Panel	DIP Switch Settings					
	SW1-1	SW1-2	SW1-3	SW1-4	SW1-5	SW1-6
All	Off*	ON	ON	ON	ON	ON

* **Note:** SW1-1 is used to enable (ON) or disable (OFF) the optional high temperature limit switch binary input (TB2 on the TCI board).

Table 4
DIP Switch Settings for Slave TCM Addresses

Slave TCM Number	DIP Switch Settings					
	S1-1	S1-2	S1-3	S1-4	S1-5	S1-6
01	ON	ON	ON	ON	Off	Off
02	Off	ON	ON	ON	Off	Off

Note: Slave TCM DIP Switches 7 and 8 must be configured as per Table 6.

Table 5
DIP Switch Settings for TCM Addresses

TCM Number	DIP Switch Settings					
	S1-1	S1-2	S1-3	S1-4	S1-5	S1-6
01	Off	ON	ON	ON	Off	ON
02	ON	Off	ON	ON	Off	ON
03	Off	Off	ON	ON	Off	ON
04	ON	ON	Off	ON	Off	ON
05	Off	ON	Off	ON	Off	ON
06	ON	Off	Off	ON	Off	ON
07	Off	Off	Off	ON	Off	ON
The following are used for the Stat 16 model only:						
08	ON	ON	ON	Off	Off	ON
09	Off	ON	ON	Off	Off	ON
10	ON	Off	ON	Off	Off	ON
11	Off	Off	ON	Off	Off	ON
12	ON	ON	Off	Off	Off	ON

Table 6
DIP Switch Settings for TCM Program Options

Option	S1-7	S1-8
Slave TCM	Off	Off
Air Conditioning Thermostat	Off	ON
Heat Pump Thermostat	ON	Off

Note: Slave TCM DIP Switches 1-6 must be configured as per Table 4.

Table 7
DIP Switch Settings for VariTrac II Central Control Panel

VariTrac II Central Control Panel	DIP Switch Settings				
	SW2-1	SW2-2	SW2-3	SW2-4	SW2-5
01	ON	Off	Off	Off	Off
02	Off	ON	Off	Off	Off
03	ON	ON	Off	Off	Off
04	Off	Off	ON	Off	Off
The following are used for the Stat 16 model only:					
05	ON	Off	ON	Off	Off
06	Off	ON	ON	Off	Off
07	ON	ON	ON	Off	Off
08	Off	Off	Off	ON	Off

DIP Switch Settings 6-8 on VariTrac II Central Control Panel

DIP Switch 2-#6 - Type of Bypass Control

If DIP switch #6 is OFF (down), the VariTrac II Central Control Panel controls the bypass damper using velocity control. When the DIP switch is in the ON (up) position, the VariTrac II Central Control Panel controls the bypass using static pressure control. The control type is determined at installation. See the VariTrac II Central Control Panel Installation Guide for more information.

DIP Switch 2-#7 - RS-232 Baud Rate Override

When DIP switch #7 is in the OFF (down) position, the RS-232 port on the VariTrac II Central Control Panel operates at the edited baud rate set up in the Central Control Panel System Setup menu. When the DIP switch is in the ON (up) position, the RS-232 port is overridden to 1200 baud.

DIP Switch 2-#8 - Local Test Mode

If DIP switch #8 is in the OFF (down) position, the VariTrac II Central Control Panel operates normally. When the DIP switch is in the ON (up) position, the VariTrac II Central Control Panel is in the Local Test Mode. See the *Local Test Mode* section of the VariTrac II Central Control Panel Operator's Guide for an explanation of Local Test Mode operation.

Input Wiring

Input Wiring Requirements

Note: All input wiring must comply with applicable electrical codes. Metal conduit may be required by local codes when running wires for the temperature sensor input or binary input.

Use only stranded, tinned copper conductors for input wiring. The temperature sensor input and binary input wiring must be shielded, twisted pair (meets or exceeds specifications for Trane ordering number 400-20-28). The recommended wire size is 18 gauge. Do not run input wires in the same conduit or wire bundle with any AC power wires.

CAUTION: Running input wires in the same conduit or wire bundle with any AC power wires may cause the Tracker to malfunction due to electrical noise.

For the Tracker enclosure, the input wires should enter the cabinet through the conduit entry holes shown in Figure 4. Input wiring connections at the Tracker are shown in Figure 7.

Outdoor Air Temperature Sensor - Analog Input Wiring

The Tracker analog (outdoor air) input temperature sensor must be a resistance thermistor device. Make all connections according to job wiring diagrams and in compliance with national and local codes.

Twisted, shielded pair wire is required for this temperature sensor wiring. We recommend using 18 gauge wire (meets or exceeds specifications for Trane ordering number 400-20-28). Use only stranded, tinned copper conductors. Do not run the temperature sensor wires in the same conduit or wire bundle with any AC power wires.

CAUTION: Running sensor wires in the same conduit or wire bundle with any AC power wires may cause a malfunction due to electrical noise.

The maximum wire length for the temperature sensor wiring is limited to 300 feet because of possible electrical noise problems with longer runs. Figures 8 and 9 show the proper methods of making wiring connections at the Tracker and at the temperature sensor.

Figure 8
Schematic Diagram of Outdoor Air Temperature Sensor

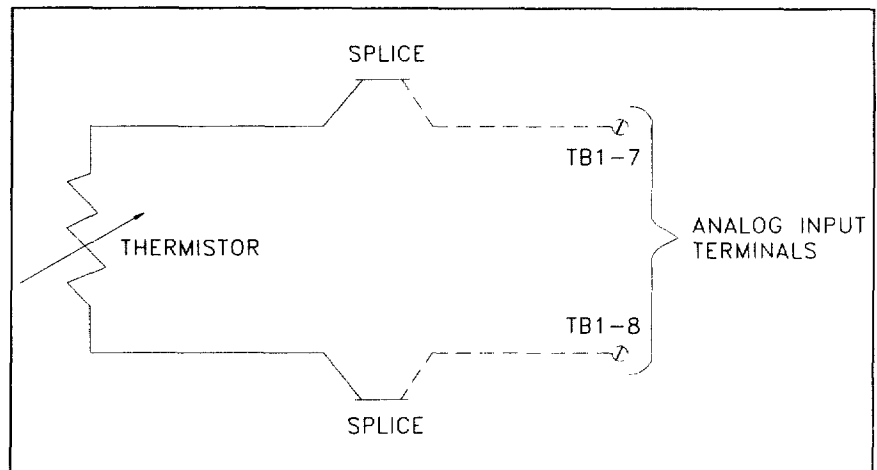

Connect one input lead at terminal TB1-7 on the Tracker terminator card. Connect the bare shield wire and the other input lead at terminal TB1-8. At the sensor, cut back and tape the bare shield wire and the shield to prevent any connection between the shield and ground.

CAUTION: *The shield must be taped at the sensor because any connection between the shield and ground will cause a malfunction.*

Figure 9 illustrates typical input wiring connections and Figure 4 shows the conduit entry locations on the Tracker. Table 8 lists the temperature sensor electrical characteristics.

Figure 9
Wire Connections at the Terminator Card and Temperature Sensor

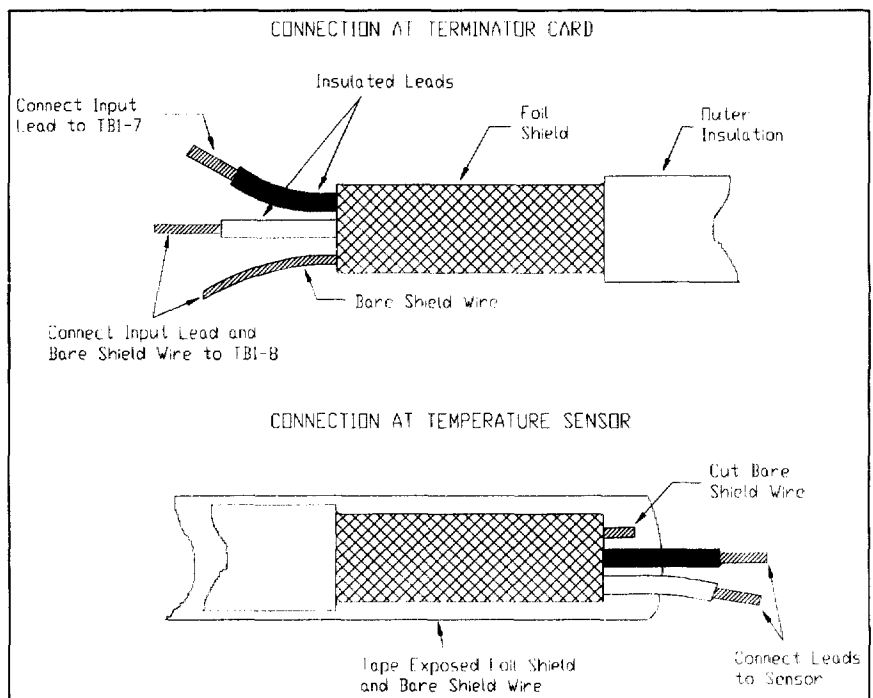

Table 8
Outdoor Air Temperature Sensor Electrical Characteristics

Temperature (° F)	Sensor Resistance (Ohms)
0	87,511
10	63,769
20	46,919
30	34,839
40	26,221
50	19,955
60	15,333
70	11,889
80	9,298
90	7,330
100	5,824
110	4,662
120	3,757
130	3,051
140	2,493
150	2,049

Binary Input Wiring

(Stat 16 Model Only)

The binary input is connected at terminals on TB1-9 and TB1-10. The binary input must have an isolated and ungrounded contact. The Tracker provides 14 VDC at 14 mA for the binary input circuit. Twisted pair wire is required for binary inputs. We recommend using 18 gauge wire (meets or exceeds specifications for Trane ordering number 400-20-28). Cut back and tape the shield at the contact to prevent any contact between the shield and ground. At the Tracker terminator card, the shield must be connected to terminal TB1-10.

CAUTION: Any connection between the shield and ground could result in an equipment malfunction.

Limit the length of the wire run to 1,000 feet or less. This 1,000 foot maximum should not be exceeded because of possible electrical noise problems with longer wire runs.

The binary input is connected at terminals on TB1-9 and TB1-10.

Edit Terminal (RS-232) Interface

An ASCII edit terminal device can be connected to the Tracker for initial system setup. It is not required for day-to-day operation of the Tracker.

Any ASCII terminal device such as a CRT or portable computer can be connected to the Tracker to monitor system status or edit changes.

The RS-232 connection at the Tracker is an RJ-12 style socket, which requires a Trane-supplied cable and a Trane-supplied modular adapter.

To connect the RJ-12 cable, remove the two screws from the right side of the face plate and swing open the face plate. Plug the cable into the RS-232 receptacle. Figure 10 shows the location of the RJ-12 port. If you connect a PC to the Tracker, terminal emulation software is required.

Figure 10
Location of RJ-12 Receptacle

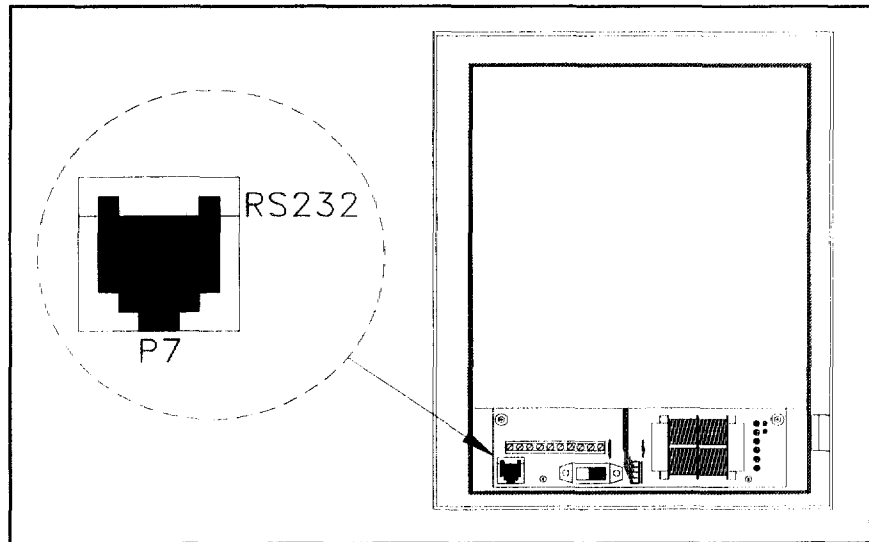
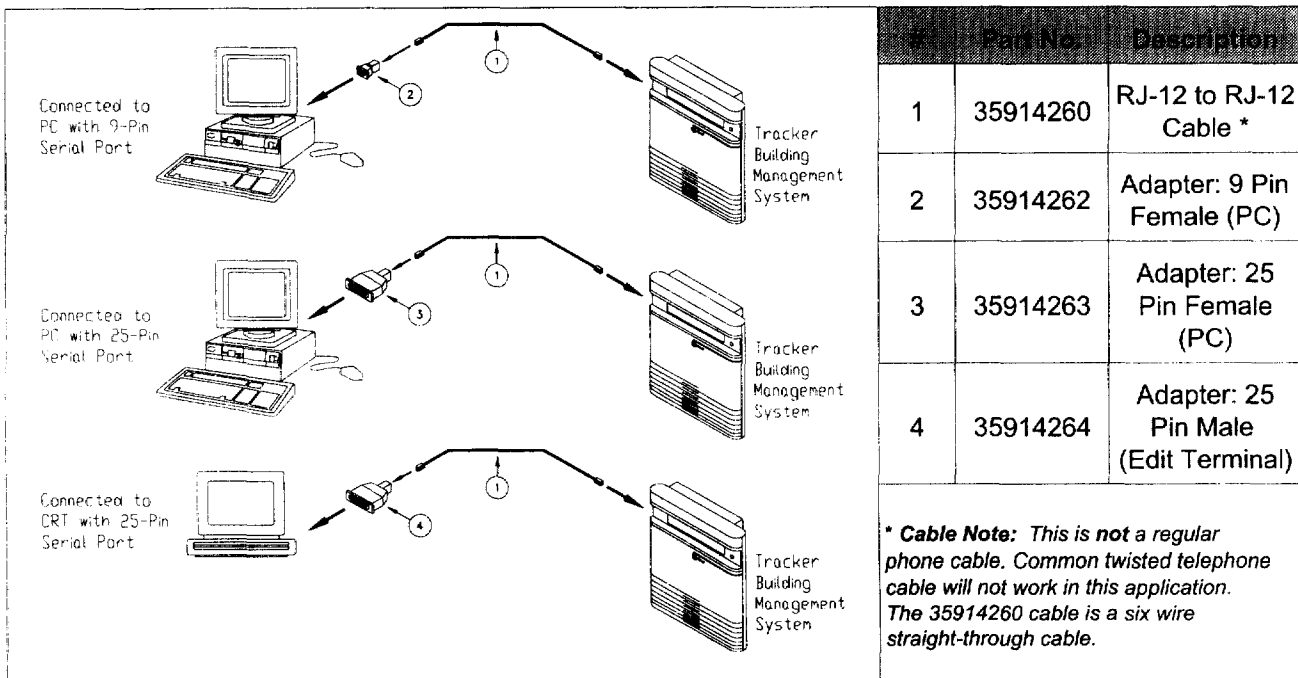

Figure 11 illustrates the connections for different edit terminals and lists the available modular adapters and cable.

Figure 11
Modular Adapters, Cable, and Connections for Edit Terminal (RS-232) Communication Devices



Settings on External Devices

When a CRT terminal or PC with terminal emulation software is used with the Tracker, the baud rate must be programmed into the Tracker memory by the operator. The baud rate is the rate of data exchange between the Tracker and the external device. The Tracker and the external device must have the same baud rate setting.

The default baud rate of the Tracker edit terminal port is 9600. Available baud rates for the Tracker are 300, 1200, 2400, 4800, and 9600. Use the highest baud rate common to both the Tracker and the external device. Refer to the operator's manual supplied with the external device to determine the available baud rates.

Other communications interface functions may also have to be set on the external device. Some of these functions and settings are listed in Table 9.

Table 9
Edit Terminal Device Settings

Function	Setting
Baud Rate	Same as Tracker
Half or Full Duplex	Full Duplex
Parity	0, Space, None
Upper/Lower Case	Upper Case Only
Auto Line Feed	Off
Number of Data Bits	8
Number of Stop Bits	1

Modem Interface for Edit Terminal

The optional Tracker 2400 baud modem interface provides a port for modem communications to a remote personal computer with terminal emulation software and a modem. Refer to the terminal emulation software literature for setup and operation requirements.

Only one communication port can be used at a time, permitting only one operator to have access to the Tracker. Figure 12 shows Tracker communication connections, including the P9 phone line jack location and the optional modem card.

Figure 12
Location of the P9 Jack and Optional Modem Card

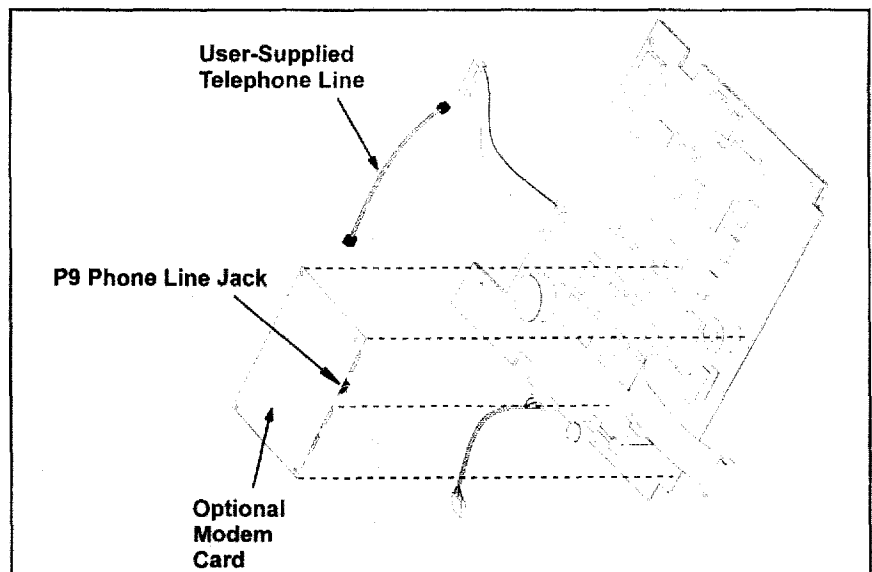

Setup Requirements for Modem at Remote PC

Trane does not support the use of non-recommended modems. Because modem specifications are subject to change, we recommend that only Trane-supplied modems be used. Other modems may work; however, it is the user's responsibility to determine the correct setup.

Tracker Installation Checkout

ON/OFF Switch

Refer to Figure 3 for the location of the major components on the Tracker terminator card.

The Tracker terminator card has an ON/OFF switch (S1), which can be used to interrupt the 24 VAC power to the card and disable all Tracker operations. This switch must be in the ON position for the Tracker to operate.

Status LEDs

The Tracker has eight red LEDs near the lower right corner of the terminator card. Figure 13 shows the Tracker LEDs.

Figure 13
Tracker Terminator Card LEDs

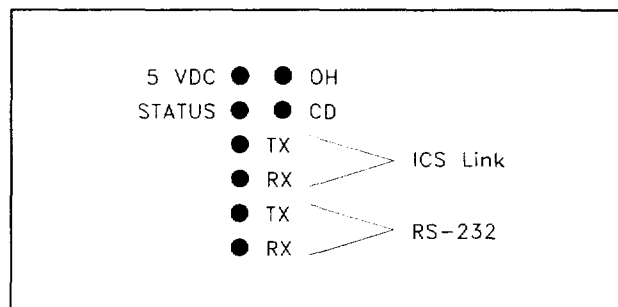

These LEDs perform the following functions:

5 VDC - This LED is lit continuously when the Tracker internal power supply is on.

Status - This LED blinks slowly for about 20 seconds at Tracker power-up. After power-up, it blinks to indicate processor activity.

OH (Off Hook) - This LED is for optional modem operation only. It is lit continuously as long as the Tracker is online (communicating) through its internal modem.

CD (Carrier Detect) - This LED is for optional modem operation only. It is lit only as communications through the phone line are initiated, and a carrier is detected. It goes out after the carrier is detected.

TX ICS (Transmit Data) - This LED is lit when the Tracker is transmitting data to any of the UCMs (Thermostat Control Modules, Voyager Rooftops, and/or VariTrac II Central Control Panels) over the communication link.

RX ICS (Receive Data) - This LED is lit when the Tracker is receiving data from any of the UCMs over the communication link.

TX RS232 (Transmit Data) - This LED is lit when the Tracker is transmitting data through the edit terminal port (P7) to an external editing device.

RX RS232 (Receive Data) - This LED is lit when the Tracker is receiving data through the edit terminal port from an external editing device.

Installation Checklist

Complete this checklist as the Tracker is installed to verify that all recommended installation procedures are accomplished before the unit is started. This checklist does not replace the detailed instructions provided in the manual. Read the entire manual carefully to become familiar with the installation procedures before installing the unit.

Shipment

- Tracker inspected for shipping damage and claim filed, if necessary.

Unit Location

- Tracker installed in environment that meets temperature and humidity requirements.
- Tracker securely mounted on wall at eye level.
- Proper clearances around Tracker.

AC Power Wiring

- Field installed AC power wiring complies with all applicable codes.
- 24 VAC line from dedicated class 2 transformer connected to Tracker at TB1.
- Voltage measured at TB1-1 to TB1-2 is 20 to 30 VAC. TB1-3 is connected to reliable earth ground.

Input Wiring

- Field installed input wiring complies with all applicable codes.
- Temperature sensor is installed with twisted, shielded pair wiring.
- Binary input is installed with twisted, shielded pair wiring (Stat 16 model only).

Communication Link Wiring

- Field installed communications wiring complies with all applicable codes.
- Tracker communication link wiring connected at TB1-4, TB1-5, and TB1-6.
- Communication link wire shields spliced at each device and taped.

Troubleshooting

Following are some troubleshooting guidelines. For problems that cannot be resolved using these guidelines, contact your Trane representative for service help.

ICS Communication Link

A common light emitting diode (LED) is useful for checking the ICS communication link. An LED such as this is available from any electronics supply source. The LED can be placed directly across the link at any UCM that is not communicating to see if the Tracker is scanning that UCM. See Figure 14.

Figure 14
Placement of LED for ICS Link Troubleshooting

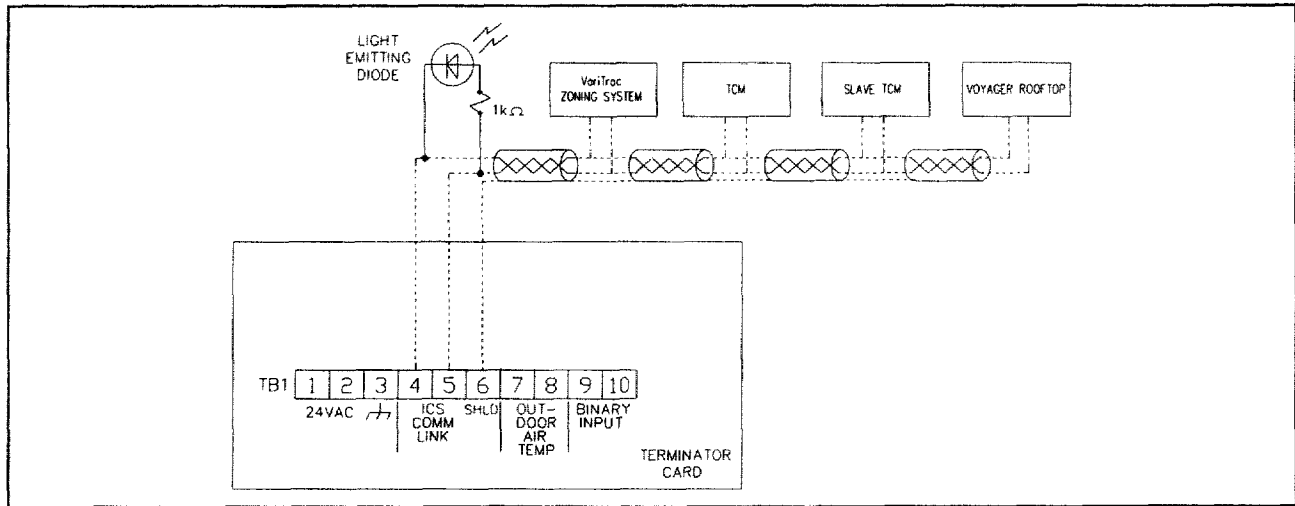

Any time the ICS transmit (TX) LED flashes on the Tracker terminator card, the LED across the UCM should flash. If not, there is a wiring problem. Check for shorts, open wires, or faulty connections on the communications link.

If the LED flashes, but the ICS receive (RX) LED never flashes, there is a UCM problem. This may be due to an incorrect address, power loss, faulty UCM, or other causes.

Figure 15 shows the Tracker terminator card LEDs. Refer to *Tracker Installation Checkout* on page 25 for descriptions of the LEDs.

Figure 15
Tracker Terminator Card LEDs

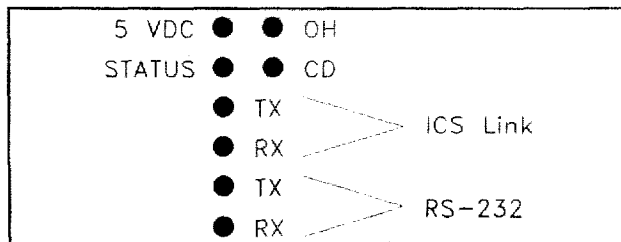

Cable for Communication Link

Many communication problems can be attributed to using the incorrect type of cable. The cable required for communications with a local CRT or PC is *not* common telephone cord. To assure using the correct type of cable, order part number 35914260 from Trane.

Hardware for Troubleshooting

A digital voltmeter cannot be used to check for ICS activity because it does not have sufficient band width. The best tool for troubleshooting ICS problems is the oscilloscope.

INDEX

B

Baud rate	23
Binary input	
Recommended wire	21
Terminal connection	21

C

Cable	
Trane ordering number	28
Caution	1
Clearance around the Tracker	11
Communication link	9

D

Daisy chain	
Example of configuration for wiring	15
Device count	9
Digital voltmeter	28
Dimensions of the Tracker	5, 11
Example	12
DIP switches	17, 18
Settings 6-8 on VariTrac II Central Ctrl Pnl	19

E

External device	
Settings	23

F

FCC registration number	3
Front panel	
Location of the panel door screw	13

H

High temperature limit switch	
Note about DIP switch settings	17
Settings for VariTrac II Central Ctrl Panel	17

I

ICS communication link	
Placement of LED for troubleshooting	27
Troubleshooting	27
Installation checklist	25

L

LEDs	
5 VDC	24
CD (Carrier Detect)	24
Example of terminator card LEDs	27
OH (Off Hook)	24
RX ICS (Receive Data)	24
RX RS232 (Receive Data)	24

Status	24
TX ICS (Transmit Data)	24
TX RS232 (Transmit Data)	24
Use with ICS communication link	27
Local test mode	
DIP switch settings	19

M

Modem	
CD (Carrier Detect) LED	24
FCC information about internal modem	3
Interface for edit terminal	23
Location of optional modem card	23
OH (Off Hook) LED	24
Setting up at remote PC	24
Mounting	
Caution about mounting	11
List of steps	11

O

Operating environment	5, 11
Operator interface	7
Outdoor air temperature sensor	
Example of wire connections	20
Maximum wire length	19
Schematic diagram	20

P

P9 jack location	23
Polarity requirement	14
Power loss	5
Power specifications	5
Power supply	13
Caution about power supply	13
Voltage measurements	14
Pulse meter	
Use with Stat 16	7

R

RJ-12	
Location of the RJ-12 port	22
Note about cable	22
RS-232	
Connection	22
DIP switch settings	19
Interface	21, 22

S

Setpoint control	7
Slave TCM	
DIP switch settings	17
Number of devices allowed on a Tracker	9

Stat 16		Operator interface	7
Binary input wiring information	21	Radio and television interference	3
Definition of Stat 16	7	What happens upon loss of power	5
Number of devices allowed	9	Trane	
Stat 7		Ordering number for wire	5
Definition of Stat 7	7	Telephone number for Service department	3
Number of devices allowed	9	Type of bypass control - DIP switches	19
Storage temperature	9		
T			
Tables		V	
DIP switch settings for slave TCM addresses	17	VAC	
DIP switch settings for TCM addresses	18	Connecting to the ComforTrac	13
DIP switch settings for TCM program options	18	VariTrac I Comfort Manager	
DIP switch settings for Voyager Rooftop	17	Number of devices allowed on a Tracker	9
DIP switches - VariTrac II Central Ctrl Panel	17	VariTrac II Central Control Panel	
DIP switches for VariTrac II Central Ctrl Pnl	18	Number of devices allowed on a Tracker	9
Edit terminal device settings	23	Voyager Rooftop	
Temperature sensor electrical characteristics	21	DIP switch settings on TCI	17
TCM		Number of devices allowed on a Tracker	9
Definition of TCM	7	W	
Number of devices allowed on a Tracker	9	Warning	1
Program options	18	Weight of the Tracker	5
Slave	7	Wiring	
Telephone number for Trane	3	Binary inputs	21
Terminator card		Communication link wiring type	5
Example of card component layout	8	Daisy chain configuration	15
Example of LEDs	24	Example of field wiring connections	16
Example of wire connections	20	Input wiring requirements	19
On/Off switch	24	Maximum length for binary inputs	21
Tracker	1	Maximum length for temperature sensor	19
Definition of Tracker	7	Outdoor air temperature sensor	19
Device counts	9	Recommended gauge	19
Example of typical application	8	Specifications for communication link wiring	6
Mounting information	5, 11	Trane ordering number	14, 19, 21

Price \$8.00

The Trane Company
Building Automation Systems Division
20 Yorkton Court
St. Paul, MN 55117

© American Standard Inc. 1996

Library	Service Literature
Product Section ..	Electronic Systems and Controllers
Product	Building Automation Systems
Model	EMTK
Literature Type	Installation Guide
Sequence	6
Date	April 15, 1996
File No.....	SV-ES-BAS-EMTK-IN-7-495
Supersedes	SV-ES-BAS-EMTK-IN-5-295 R01
File No.....	22-6036-05
Supersedes	22-6036-04