

# Installation

## C-Series Outdoor Unit Series

Models:

4TUK4512A10N0\*  
4TUK4518A10N0\*  
4TUK4524A10N0\*  
4TUK4530A10N0\*

4TUK4536A10N0\*  
4TUK4542A10N0\*  
4TUK4548A10N0\*

### SAFETY WARNING

Only qualified personnel should install and service the equipment. The installation, starting up, and servicing of heating, ventilating, and air-conditioning equipment can be hazardous and requires specific knowledge and training. Improperly installed, adjusted or altered equipment by an unqualified person could result in death or serious injury. When working on the equipment, observe all precautions in the literature and on the tags, stickers, and labels that are attached to the equipment.



# Introduction

## Warnings, Cautions, and Notices

Safety advisories appear throughout this manual as required. Your personal safety and the proper operation of this machine depend upon the strict observance of these precautions.

---

The three types of advisories are defined as follows:

 <b>WARNING</b>	Indicates a potentially hazardous situation which, if not avoided, could result in death or serious injury.
 <b>CAUTION</b>	Indicates a potentially hazardous situation which, if not avoided, could result in minor or moderate injury. It could also be used to alert against unsafe practices.
<b>NOTICE</b>	Indicates a situation that could result in equipment or property-damage only accidents.

---

## Important Environmental Concerns

Scientific research has shown that certain man-made chemicals can affect the earth's naturally occurring stratospheric ozone layer when released to the atmosphere. In particular, several of the identified chemicals that may affect the ozone layer are refrigerants that contain Chlorine, Fluorine and Carbon (CFCs) and those containing Hydrogen, Chlorine, Fluorine and Carbon (HCFCs). Not all refrigerants containing these compounds have the same potential impact to the environment. Trane advocates the responsible handling of all refrigerants-including industry replacements for CFCs such as HCFCs and HFCs.

## Important Responsible Refrigerant Practices

Trane believes that responsible refrigerant practices are important to the environment, our customers, and the air conditioning industry. All technicians who handle refrigerants must be certified. The Federal Clean Air Act (Section 608) sets forth the requirements for handling, reclaiming, recovering and recycling of certain refrigerants and the equipment that is used in these service procedures. In addition, some states or municipalities may have additional requirements that must also be adhered to for responsible management of refrigerants. Know the applicable laws and follow them.

### **WARNING**

#### **Proper Field Wiring and Grounding Required!**

**Failure to follow code could result in death or serious injury. All field wiring MUST be performed by qualified personnel. Improperly installed and grounded field wiring poses FIRE and ELECTROCUTION hazards. To avoid these hazards, you MUST follow requirements for field wiring installation and grounding as described in NEC and your local/state electrical codes. Failure to follow code could result in death or serious injury.**

**⚠ WARNING****Personal Protective Equipment (PPE) Required!**

Failure to wear proper PPE for the job being undertaken could result in death or serious injury. Technicians, in order to protect themselves from potential electrical, mechanical, and chemical hazards, **MUST** follow precautions in this manual and on the tags, stickers, and labels, as well as the instructions below:

- Before installing/servicing this unit, technicians **MUST** put on all PPE required for the work being undertaken (Examples; cut resistant gloves/sleeves, butyl gloves, safety glasses, hard hat/bump cap, fall protection, electrical PPE and arc flash clothing). **ALWAYS** refer to appropriate Material Safety Data Sheets (MSDS)/Safety Data Sheets (SDS) and OSHA guidelines for proper PPE.
- When working with or around hazardous chemicals, **ALWAYS** refer to the appropriate MSDS/SDS and OSHA/GHS (Global Harmonized System of Classification and Labelling of Chemicals) guidelines for information on allowable personal exposure levels, proper respiratory protection and handling instructions.
- If there is a risk of energized electrical contact, arc, or flash, technicians **MUST** put on all PPE in accordance with OSHA, NFPA 70E, or other country-specific requirements for arc flash protection, **PRIOR** to servicing the unit. **NEVER PERFORM ANY SWITCHING, DISCONNECTING, OR VOLTAGE TESTING WITHOUT PROPER ELECTRICAL PPE AND ARC FLASH CLOTHING. ENSURE ELECTRICAL METERS AND EQUIPMENT ARE PROPERLY RATED FOR INTENDED VOLTAGE.**

## Copyright

This document and the information in it are the property of Trane, and may not be used or reproduced in whole or in part without written permission. Trane reserves the right to revise this publication at any time, and to make changes to its content without obligation to notify any person of such revision or change.

## Trademarks

All trademarks referenced in this document are the trademarks of their respective owners.

## Revision History

- Added 12 MBH capacity unit.
- Corrected error in electrical data for electrical heater power supply connections.
- Added additional indoor unit models.
- Added notes for wind baffle.
- Removed warranty information which is shipped as a stand-alone document.

# Table of Contents

Model Number Description .....	6
Preparing for Installation .....	7
Dimensions and Weights .....	7
Minimum Operating Clearances .....	9
Location Considerations .....	11
Moving the Outdoor Unit .....	13
Unit Installation .....	14
Wall Mounting .....	14
Roof or Ground Installation .....	14
Wind Baffle .....	16
Air Guide Duct .....	18
Refrigerant Piping .....	19
Selecting Refrigerant Piping .....	19
Pipe Diameter .....	19
Refrigerant Piping Minimum Thickness .....	20
Refrigerant Piping Maximum Length and Height Differences .....	20
Storing Refrigerant Piping .....	20
Installing Refrigerant Piping .....	21
Overview .....	21
Pipe Cutting .....	21
Nitrogen Flushing While Brazing .....	22
Flared Pipe Connections .....	22
Connecting Piping to the Outdoor Unit .....	24
Electrical Wiring .....	25
Power Wiring .....	25
Grounding .....	28
Installing a Grounding Rod .....	28
Installing the Grounding Cable .....	28
Communications Wiring .....	30
System Leak Testing Procedure .....	31
System Evacuation Procedure .....	33
Connecting the Drain Line .....	34
Insulation .....	35
Insulating Refrigerant Piping .....	35
Insulating the Drain Line .....	35
Refrigerant .....	36

---

Calculating the Refrigerant .....	36
Charging the Refrigerant .....	37
Control System .....	38
Configuring the System .....	39
Model 4TUK4512/18* .....	39
Models 4TUK4524/30/36/42/48 .....	39
Monitoring System Settings .....	41
Changing an Outdoor Unit Address .....	42
Pre-Start Checks .....	43
Test Operation .....	44
Service: Pump Down Procedure .....	46
Relocating the Outdoor Unit .....	47

# Model Number Description

4	T	U	K	4	5	1	8	A	1	0	N	0	*
1	2	3	4	5	6	7	8	9	10	11	12	13	14

**Digit 1: Refrigerant**

4 = R-410A

**Digit 2: Brand Name**

T = Mini-split outdoor unit

**Digit 3: System type**

U = Universal match heat pump

**Digit 4: Configuration type**

K = Heat pump

**Digit 5: Family**

4 = Standard model

**Digit 6: Series number**

5 = Standard model

**Digit 7, 8 = Nominal capacity (Btu/h x 1,000)**

- 18 = 18,000 Btu/h
- 24 = 24,000 Btu/h
- 30 = 30,000 Btu/h
- 36 = 36,000 Btu/h
- 42 = 42,000 Btu/h
- 48 = 48,000 Btu/h

**Digit 9: Major development sequence**

A = First development sequence

**Digit 10: Electric power supply characteristics**

1 = 208-230/60/1

**Digit 11: Reserve for future use**

0 = Not currently used

**Digit 12: Region of sale**

N = North America (UL or ETL)

**Digit 13: Reserved for future use**

0 = Not currently used

**Digit 14: Minor design sequence**

A = First design sequence

**Digit 15: Service digit (not used for ordering)**

- A = First sequence
- B = Second sequence

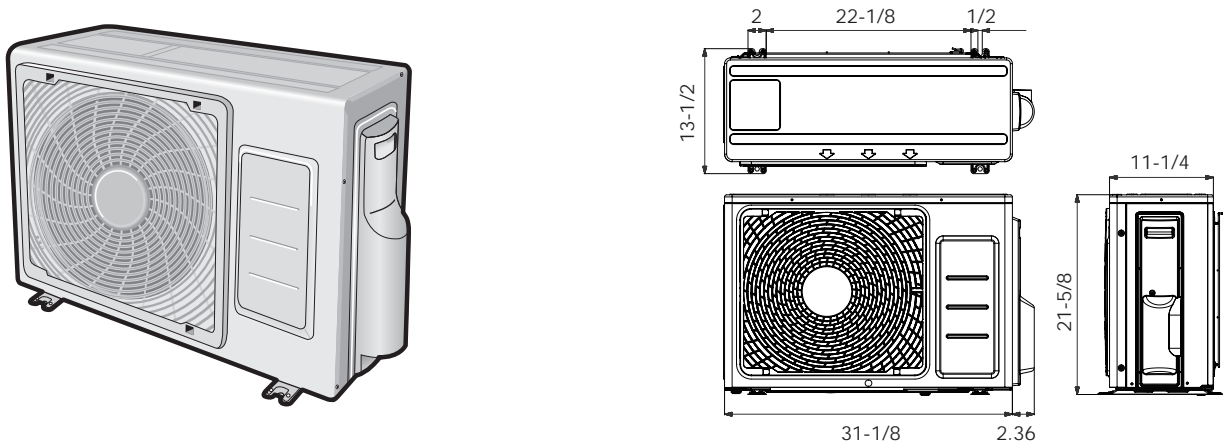
# Preparing for Installation

## Dimensions and Weights

**Table 1. Dimensions and weights for 12 MBH capacity units**

Outdoor unit capacity (MBH)	Model number	Dimensions: WxHxD (in.)	Weight (lb)	Shipping dimensions: WxHxD (in.)	Shipping weight (lb)
12	4TUK4512A10N0*	31-1/8 x 11-1/4 x 21-5/8	79.8	36.46 x 15.2 x 25.2	85.5

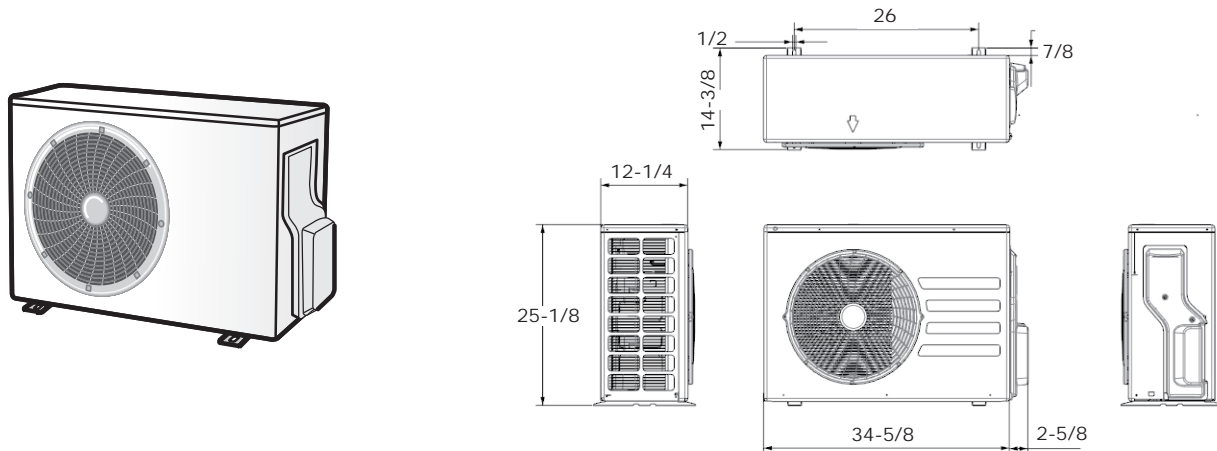
**Figure 1. Dimensional drawing for 12 MBH capacity units:**



**Table 2. Dimensions and weights for 18 MBH capacity units**

Outdoor unit capacity (MBH)	Model number	Dimensions: WxHxD (in.)	Weight (lb)	Shipping dimensions: WxHxD (in.)	Shipping weight (lb)
18	4TUK4518A10N0*	34-5/8 x 25-1/8 x 12-1/4	99.2	40-1/4 x 29-1/2 x 16-1/4	105.8

**Dimensional drawing for 18 MBH capacity units**

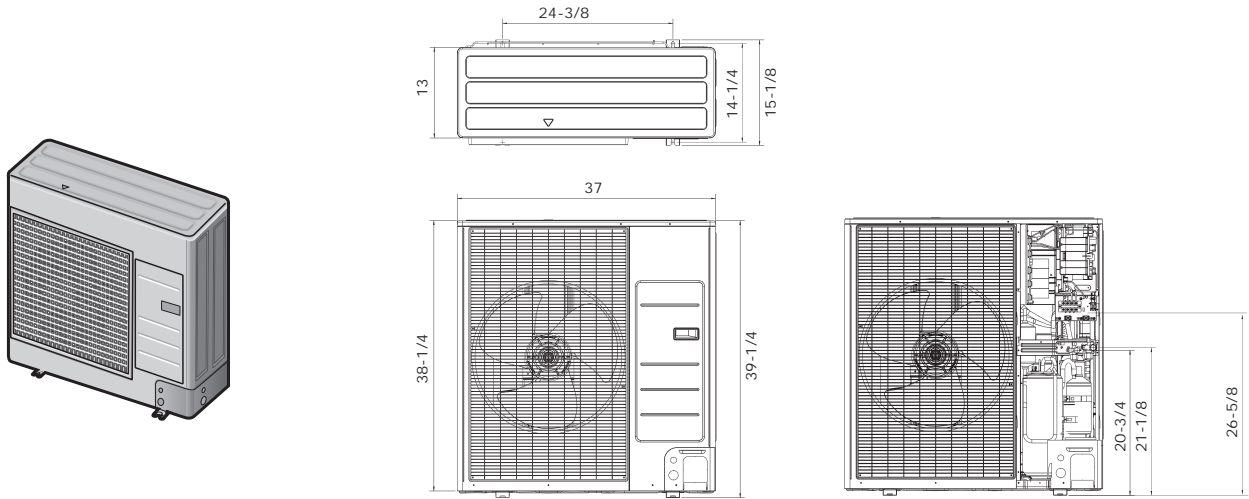


## Preparing for Installation

**Table 3. Dimensions and weights for 24 and 30 MBH capacity units**

Outdoor unit capacity (MBH)	Model number	Dimensions: WxHxD (in.)	Weight (lb)	Shipping dimensions: WxHxD (in.)	Shipping weight (lb)
24	4TUK4524A10N0*	37 x 39-1/4 x 13	142.20	39-1/8 x 43-1/8 x 16-3/4	153.22
30	4TUK4530A10N0*		154.22		163.14

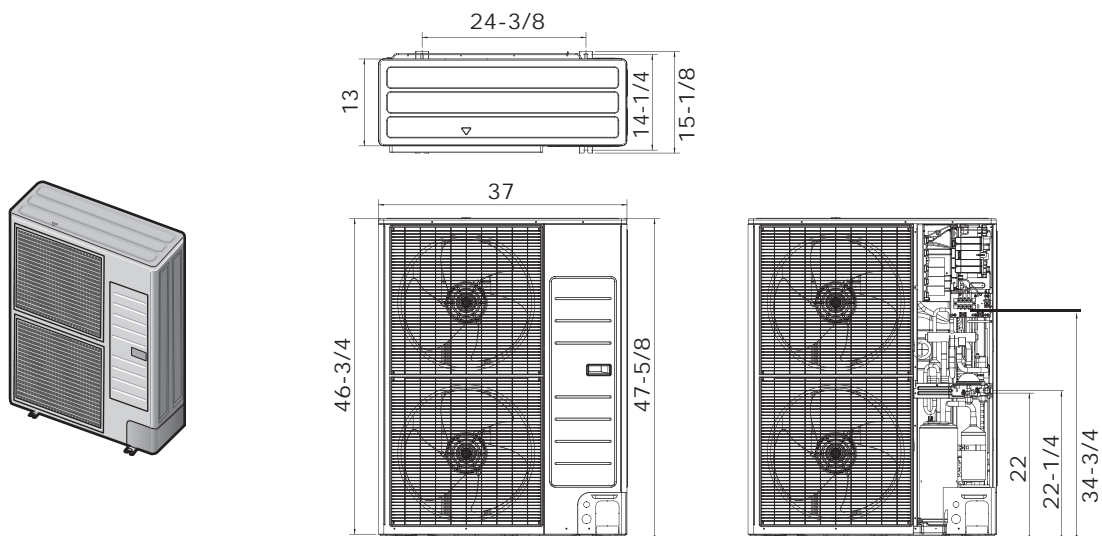
**Figure 2. Dimensional drawing for 24 and 30 MBH capacity units**



**Table 4. Dimensions and weights for 36, 42, and 48 MBH capacity units**

Outdoor unit capacity (MBH)	Model number	Dimensions: WxHxD (in.)	Weight (lb)	Shipping dimensions: WxHxD (in.)	Shipping weight (lb)
36	4TUK4536A10N0*	37 x 47-5/8 x 13	194.01	39-1/8 x 54-5/8 x 16-3/4	216.05
42	4TUK4542A10N0*				
48	4TUK4548A10N0*				

**Figure 3. Dimensional drawing for 36, 42, and 48 MBH capacity units**





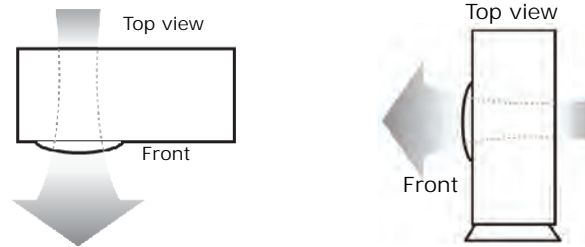
## Minimum Operating Clearances

Install units as shown in the illustrations below (Figure 4, p. 9, Figure 5, p. 9, and Figure 6, p. 10), observing ventilation and service requirements. Space requirements are based on cooling mode operation and an outdoor temperature of 95°F (35°C). More space is required if the outdoor temperature is higher than 95°F (35°C) or if the area is easily heated by solar radiation.

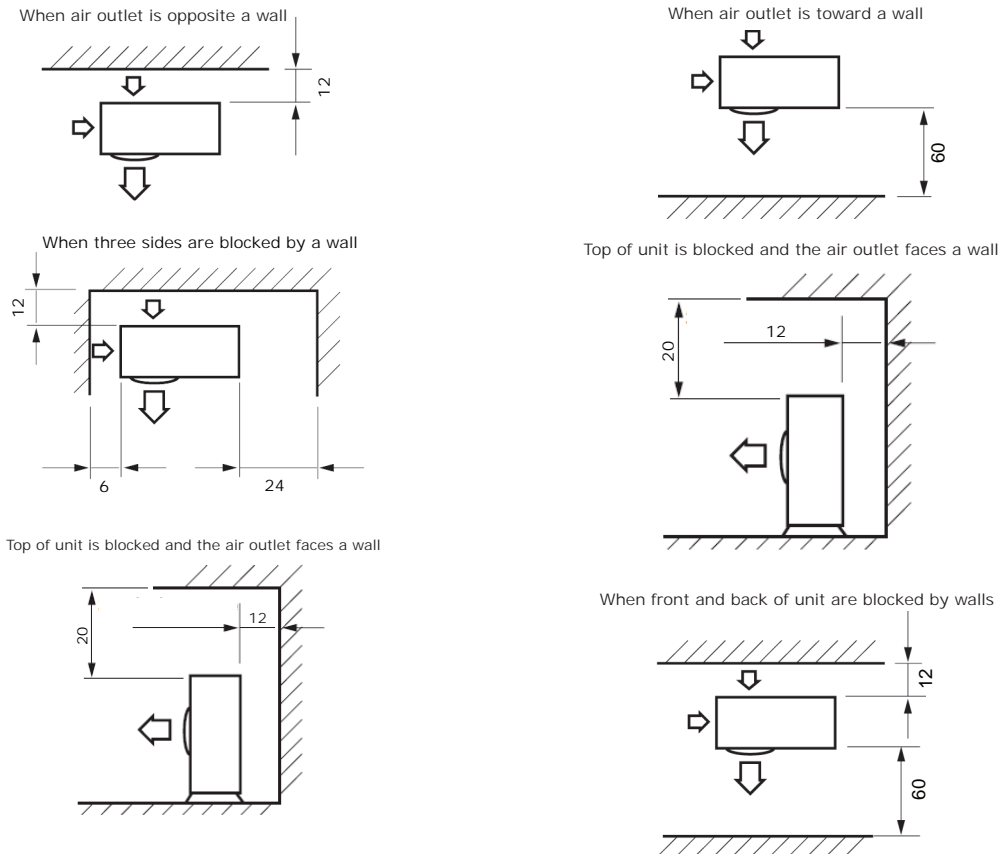
**Notes:**

- The front of the unit is curved and has the name brand logo on it.
- Clearances listed in this manual are minimum for system operation. All installations shall comply with codes and standards adopted by the Authority Having Jurisdiction (AHJ).
- If a wind baffle is installed, measure the clearance from the front of the unit rather than from the front of the wind baffle, as shown in the following illustrations.

**Figure 4. Air flow direction**



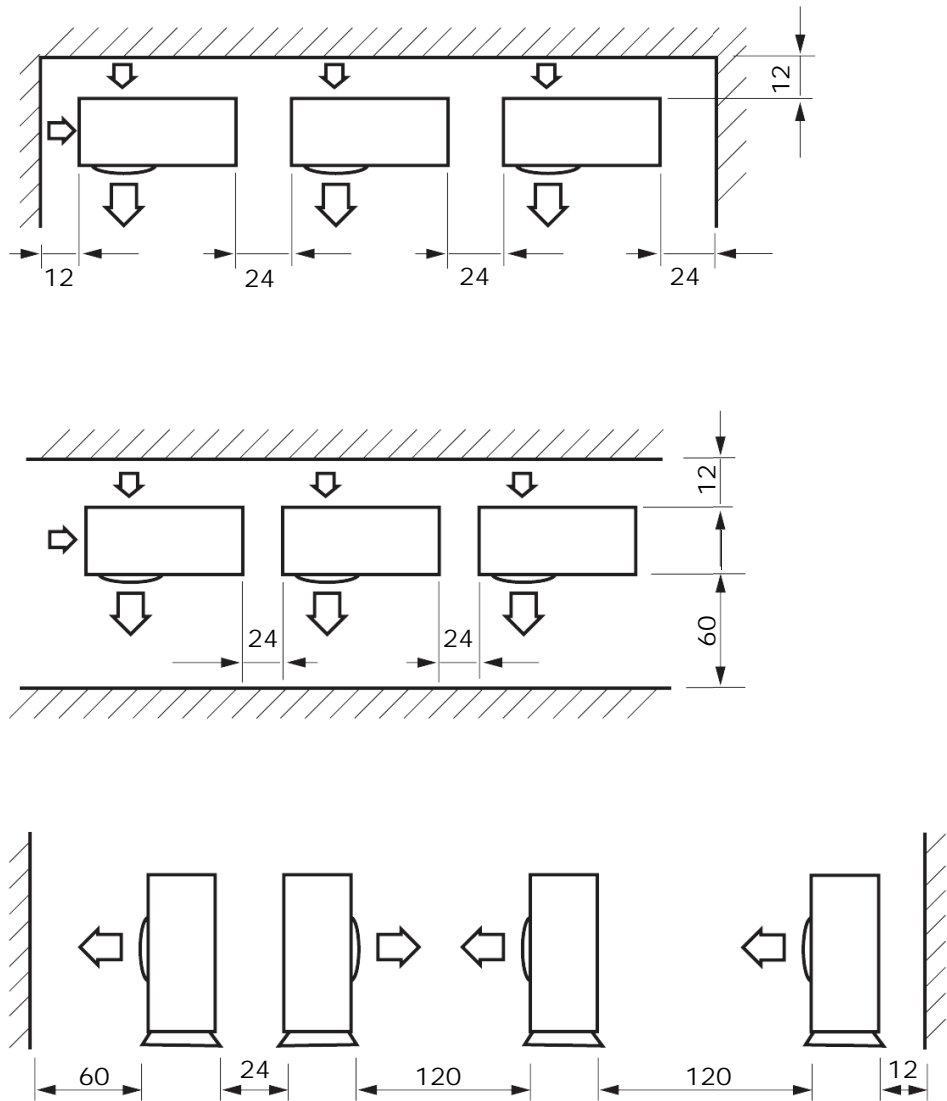
**Figure 5. Minimum operating clearances for a single unit installation**



**Figure 6. Minimum operating clearances for a multiple-unit installation**

**Notes:**

- The front of the unit is curved and has the name brand logo on it.
- Clearances listed in this manual are minimum for system operation. All installations shall comply with codes and standards adopted by the Authority Having Jurisdiction (AHJ).
- If a wind baffle is installed, measure the clearance from the front of the unit rather than from the front of the wind baffle, as shown in the following illustrations.

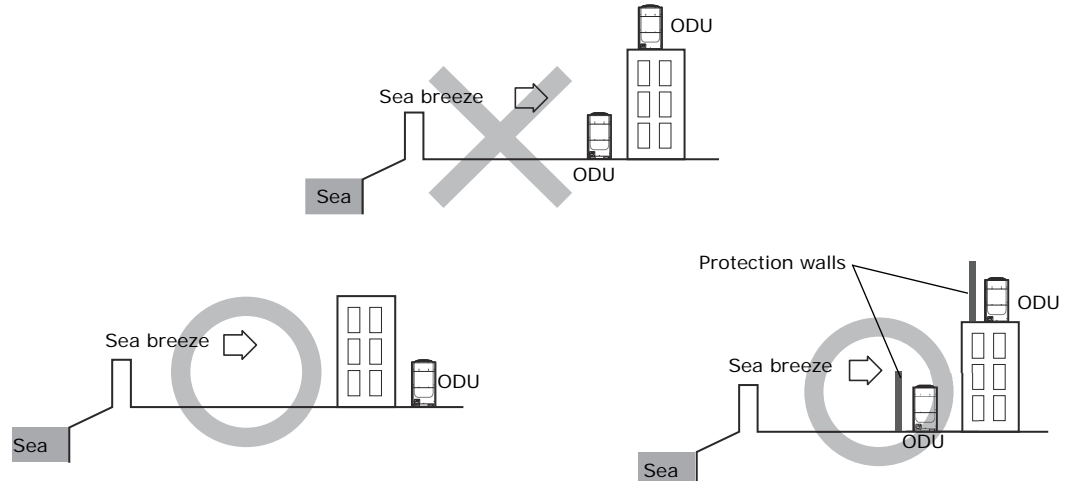


## Location Considerations

Choose an installation location based on the following considerations:

- Install the outdoor unit:
  - On a supporting structure that can bear the weight of the outdoor unit.
  - With sufficient clearances around the unit for service and repairs.
  - On a flat surface that does not collect rain water.
  - Upright (not on its side or upside down).
  - In a well ventilated location.
  - Away from strong wind.
  - So that passageways and thoroughfares are not blocked.
  - Where there is no risk of flammable gas leakage.
  - Where there is no exposure to salt, machine oil, sulfide gas, or corrosive environmental conditions.
  - Away from sea breeze.

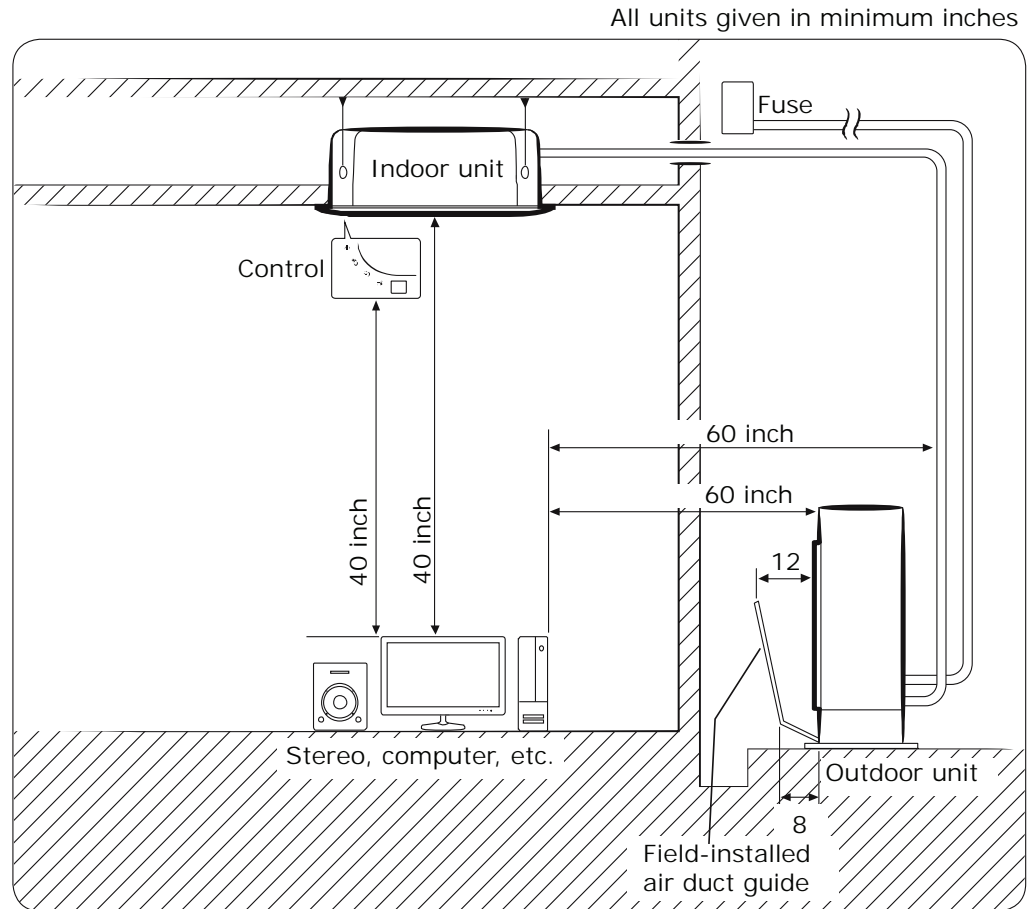
**Note:** For seacoast applications, block the unit from direct exposure to sea breeze by installing the unit behind a structure (such as a building) or a protective wall that is 1.5 times higher than the unit, leaving 28 in. of space between the wall and unit for air circulation. Consult an installation expert about taking anti-corrosion measures, such as removing salinity on the outdoor coil and applying a rust inhibitor more frequently than once a year.



- At least 9.84 ft away from equipment that generates electromagnetic waves.

## Preparing for Installation

- Maintaining sufficient clearances from equipment such as radios, computers, stereo equipment.



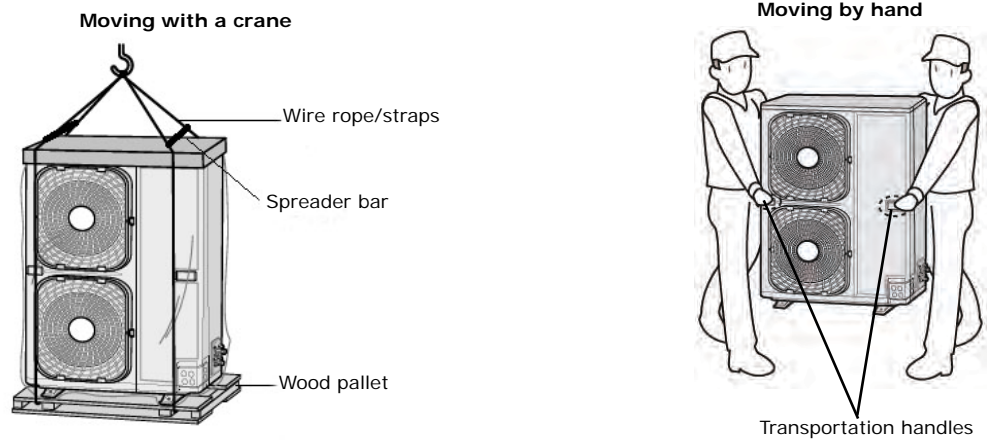
- Far enough away from people living and working nearby so that hot discharge air or noise do not disturb them. For installations other than roof or ground, the minimum recommended height is 6.6 ft to prevent passersby from being exposed to hot discharge air.
- Away from flammable materials.
- Ensure that condensate water generated by the outdoor unit can drain smoothly away from the unit.
- Install the power and communication cables in a separately installed enclosure.
- If installing on a high place such as a roof, a fence or guard rail should be installed around it to safeguard it from falling.
- If there is a potential for accumulated snow to block the air inlet or heat exchanger, install the unit on a higher base.
- R-410A refrigerant is a safe, nontoxic and nonflammable refrigerant. However, if there is a concern about a dangerous level of refrigerant concentration in the case of refrigerant leakage, add extra ventilation.
- Avoid installing the outdoor unit where corrosive gases, such as sulfur oxides, ammonia, and sulfurous gas, are produced. If unavoidable, consult with an installation specialist about using a corrosion-proof or anti-rust additive to protect the unit coils.

## Moving the Outdoor Unit

Follow these guidelines when moving the outdoor unit:

- Before moving the unit, determine a path that can support its weight.
- Do not lay the unit on its side and do not slant the unit more than 30 degrees.
- Take care to avoid injury while moving the unit; the surface of the heat exchanger is sharp.
  - If moving the unit with a crane, fasten the wire rope as shown in [Figure 7](#). To protect damage or scratches to the unit, use a spreader bar.
  - If the unit is being moved a short distance by hand, two people should lift and carry it together using the transportation handles on the side of the unit, as shown in [Figure 7](#).

**Figure 7. Moving the outdoor unit**



# Unit Installation

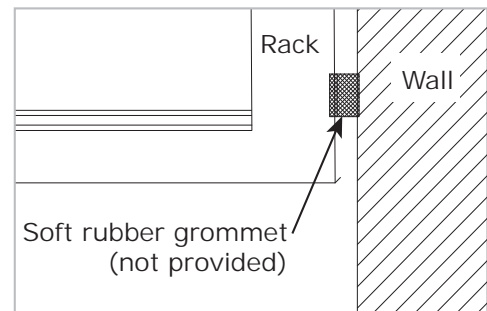
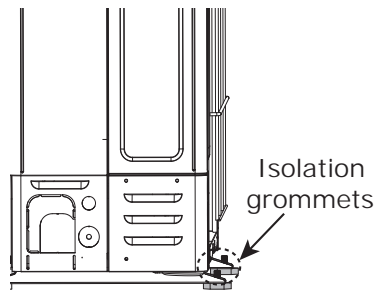
Follow these guidelines for installing an outdoor unit.

**Important:** *The manufacturer is not responsible for damage incurred for installations that have not followed these guidelines.*

## Wall Mounting

**Important:** *If the unit weighs over 133 lb, suspending it from a wall is not recommended.*

- If installing the unit on a wall, ensure that the wall is able to support the weight of the outdoor unit and rack.
- For better weight distribution, install the rack as close to a supporting column as possible.
- To reduce vibration and to minimize noise, install isolation grommets (not provided):
  - Between the supporting rack and the wall.
  - Beneath the feet of the unit.
  - Between the unit and the rack.

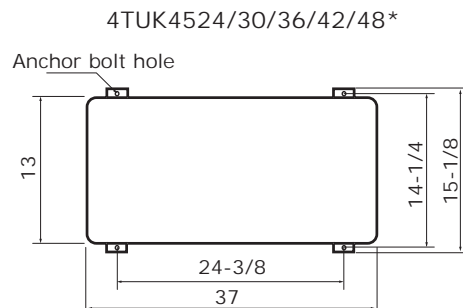
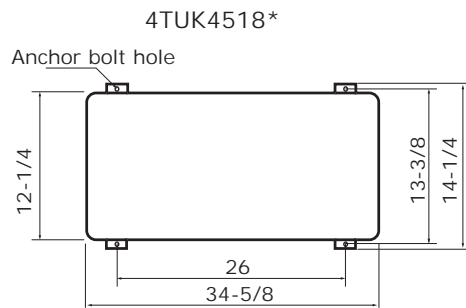
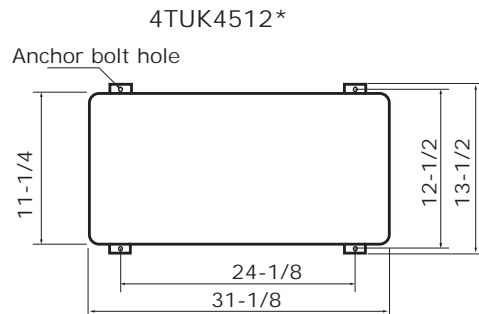
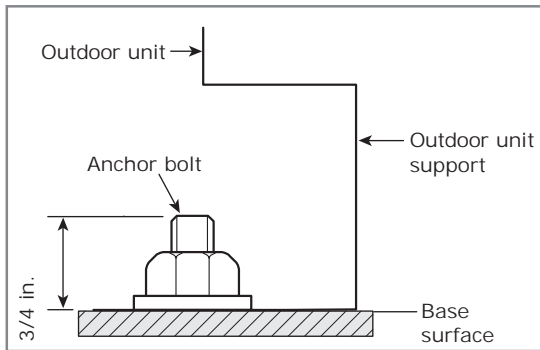
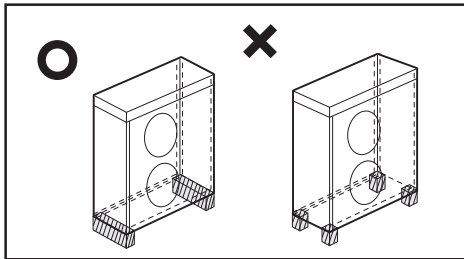


## Roof or Ground Installation

Follow these requirements and refer to [Figure 8, p. 15](#):

- If installing the unit on the ground or on a roof, secure it to a rigid and stable base using M10 anchor bolts.
- Use zinc-plated or stainless steel nuts and bolts.
- Use a rubber washer between the bolt and the unit to prevent bimetallic corrosion.
- Consult with the Authority Having Jurisdiction (AHJ) regarding adopted building codes and standards that detail securing the unit to withstand wind and seismic interruptions.
- The anchor bolt must be 3/4 inch or higher from surface of the base.
- Make a drain pit around the base to ensure proper drainage.

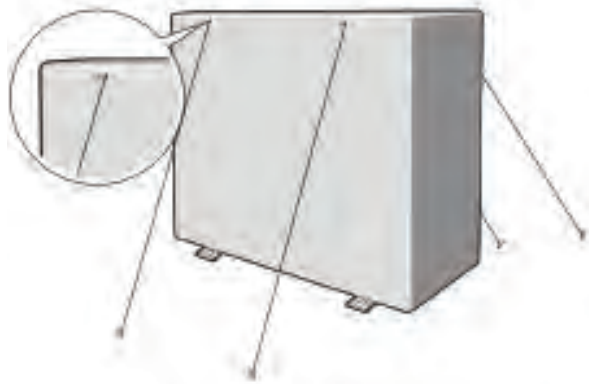
**Figure 8. Securing the unit to the roof or ground**



If you cannot attach the unit to the base or if the unit needs additional support, secure it with wires as follows:

1. Loosen the four screws at the top of the unit and wrap wire around each of them.
2. Tighten the screws.
3. Stake the wires to the ground.

**Figure 9. Securing the unit with wire**



### Wind Baffle

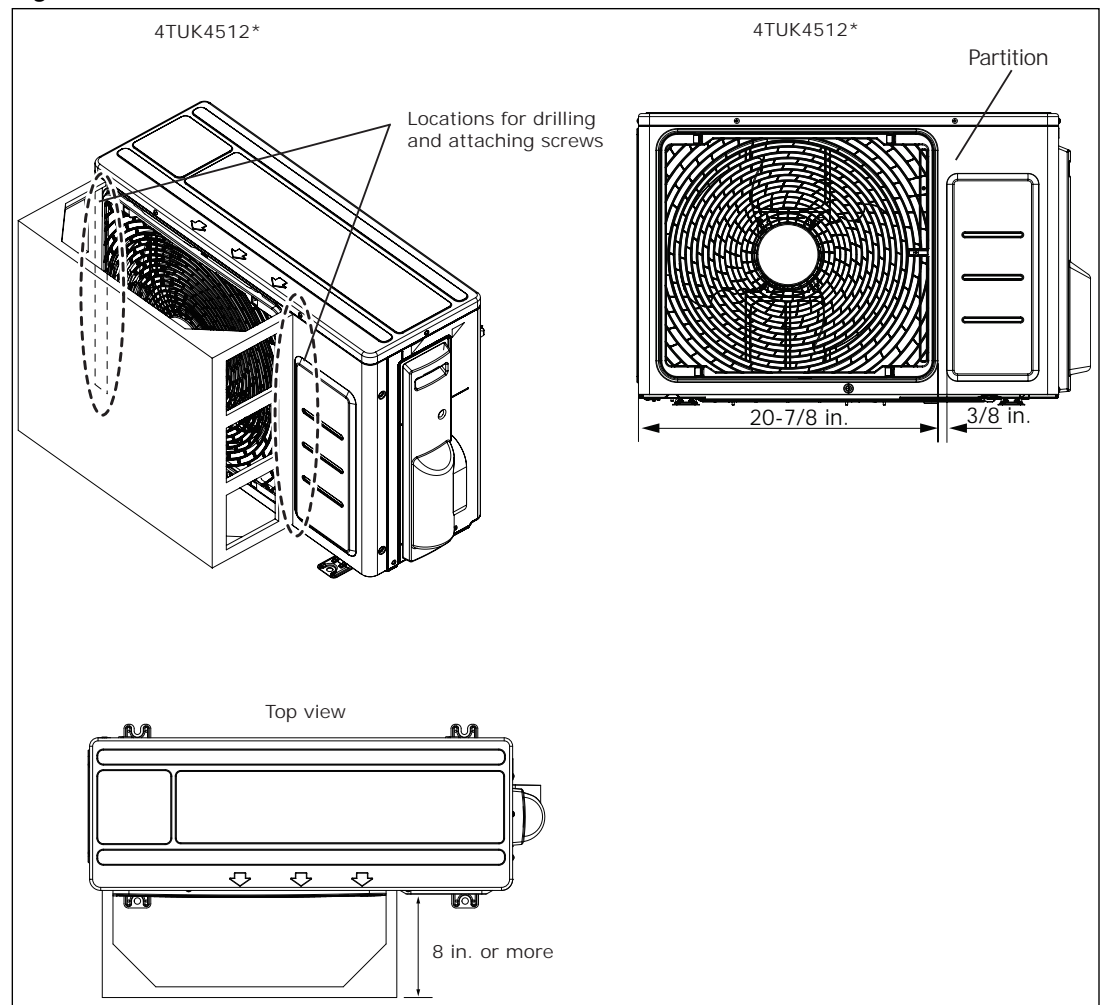
If the outdoor unit is exposed to direct strong winds, or when low ambient cooling is between 0°F and 23°F, a wind baffle is required.

Refer to [Figure 10](#). Follow the instructions provided with the wind baffle kit to ensure proper installation.

**Notes:**

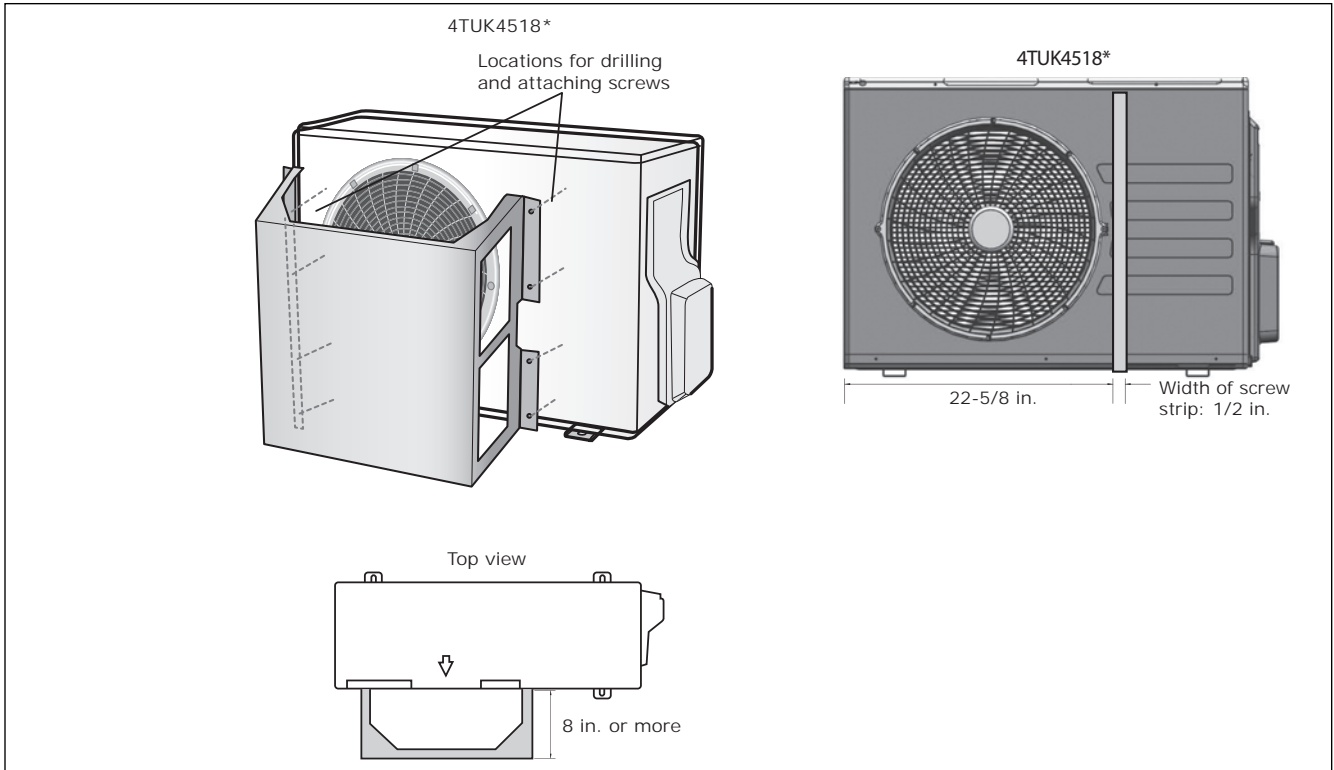
- The wind baffle should be used only when the baffle is installed into the prevailing wind. The rear of the unit should be oriented towards an adequately sized wall or wind block. The wind baffle may not be effective if wind impinges on the sides or rear of the unit.
- Do not install a wind baffle if there are obstructions to the sides or above the unit.
- The outdoor unit must comply with operating clearances as described in “[Minimum Operating Clearances](#)” p. 9.
- If the application does not conform to the above recommendations, contact your local manufacturer sales office for further assistance.

**Figure 10. Wind baffle installation: 4TUK4512\***

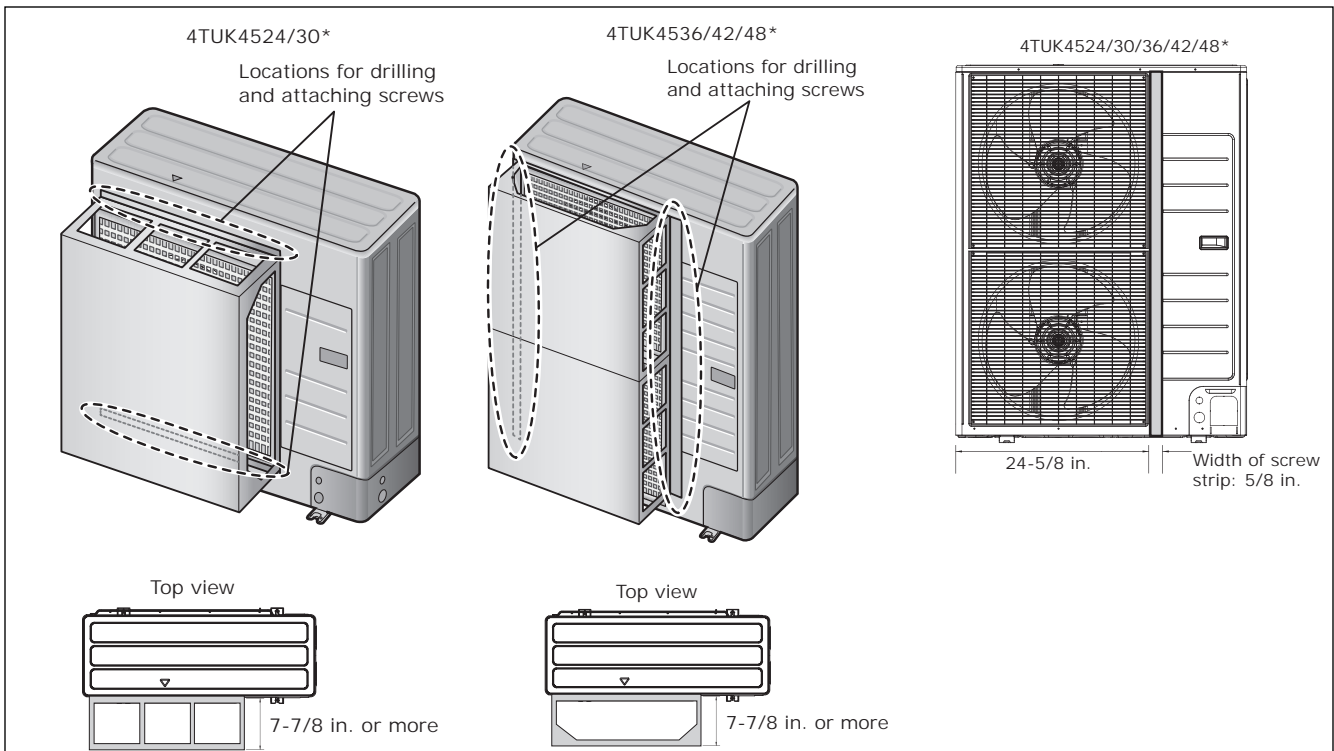




**Figure 11. Wind baffle installation: 4TUK4518\***



**Figure 12. Wind baffle installation: 4TUK4524/30/36/42/48\***



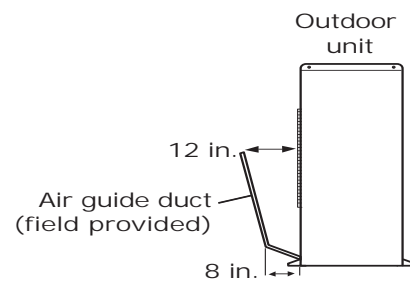
## Unit Installation

---

### Air Guide Duct

An air guide duct (not available through Trane) can be installed on the guard fan. Make sure that the installation screws for the air guide duct do not damage the copper piping.

Maintain clearances between the air guide duct and the unit as shown.



# Refrigerant Piping

This section contains information on selecting, storing, and connecting refrigerant piping.

## Selecting Refrigerant Piping

Refrigerant piping diameter, thickness, and temper is selected according to length, as specified in this section.

**Notes:**

- Use ACR piping, as specified in ASTM B280-13, Standard Specification for Seamless Copper Tube for Air Conditioning and Refrigeration Field Service.
- If there is a risk of decreased performance caused by pipe length, use piping that is one size larger than that specified in this section.

All systems must be selected through the manufacturer’s provided selection software and reviewed by the local sales office to ensure that all required components are accounted for and that system performance meets the specific job requirements.

Use the following procedure:

1. Obtain the selection report from the designer.
2. Mark the piping “tree” diagram with job site changes:
  - Line length changes
  - Vertical changes between components
  - Indoor unit location changes
  - Outdoor unit location changes
3. Submit changes to the designer and obtain the final report to ensure that the refrigeration lines are correctly sized and the system weigh-in charge is accurate.

## Pipe Diameter

**Table 5. Outdoor unit pipe diameter based on unit capacity**

Outdoor unit capacity (MBH)	Liquid pipe (in.)	Gas pipe (in.)
12	1/4	3/8
18		1/2
24		5/8
30	3/8	
36		
42		
48		

## Refrigerant Piping

### Refrigerant Piping Minimum Thickness

**Important:** Use copper piping that is approved for R-410A according to state and local codes.

**Table 6. Refrigerant piping minimum thickness based on pipe diameter**

Outer diameter (in.)	Minimum thickness (in.)
1/4	0.028
3/8	0.028
1/2	0.031
5/8	0.039
3/4	0.035
7/8	0.035

### Refrigerant Piping Maximum Length and Height Differences

Table 7 gives the maximum total refrigerant piping length and the allowable height differences between the outdoor and indoor unit.

**Table 7. Maximum refrigerant piping length and height difference between indoor and outdoor units**

Unit model (MBH)	Maximum total piping length (ft)	Maximum piping height difference between indoor and outdoor units (ft)
12	65	49
18	98	65
24	164	98
30		
36	246	
42		
48		

### Storing Refrigerant Piping

To prevent foreign materials or water from entering the pipe, storing method and sealing method (especially during installation) is very important. Apply correct sealing method depending on the environment (see Table 8).

**Table 8. Refrigerant pipe storage factors**

Storage location	Storage time	Sealing type
Outdoor	Longer than one month	Pipe pinch
	Shorter than one month	Taping
Indoor	—	Taping

## Installing Refrigerant Piping

### ⚠ WARNING

#### Hazard of Explosion and Deadly Gases!

Failure to follow all proper safe refrigerant handling practices could result in death or serious injury. Never solder, braze or weld on refrigerant lines or any unit components that are above atmospheric pressure or where refrigerant may be present. Always remove refrigerant by following the guidelines established by the EPA Federal Clean Air Act or other state or local codes as appropriate. After refrigerant removal, use dry nitrogen to bring system back to atmospheric pressure before opening system for repairs. Mixtures of refrigerants and air under pressure may become combustible in the presence of an ignition source leading to an explosion. Excessive heat from soldering, brazing or welding with refrigerant vapors present can form highly toxic gases and extremely corrosive acids.

### NOTICE:

#### System Component Damage!

Do not remove the seal caps from refrigerant connections, or open the service valves until prepared to braze refrigerant lines to the connections. Excessive exposure to atmosphere (> 5 min.) may allow moisture or dirt to contaminate the system, damaging valve seals and causing ice formation in system components.

## Overview

1. Cut or extend field-supplied piping as needed. To extend pipes, braze or using flared pipe connections (not supplied). Refer to ["Pipe Cutting"](#) p. 21, ["Nitrogen Flushing While Brazing"](#) p. 22, and ["Flared Pipe Connections"](#) p. 22.)
2. Make sure that pipes are free of dirt, debris, and moisture, and do not leak. (Refer to ["System Leak Testing Procedure"](#) p. 31).
3. Braze or use flared pipe connections to install piping. Refer to ["Connecting Piping to the Outdoor Unit"](#) p. 24).

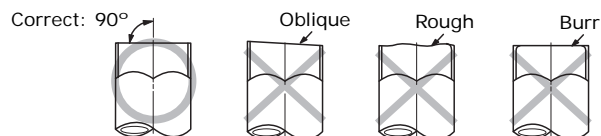
## Pipe Cutting

Required tools:

- Pipe cutter
- Reamer
- Pipe holder

1. Using a pipe cutter, cut the pipe so that the cut edge is at 90° to the side of the pipe.
2. Use a reamer to remove all burrs at the cut edge.

Examples of correctly and incorrectly cut pipes.



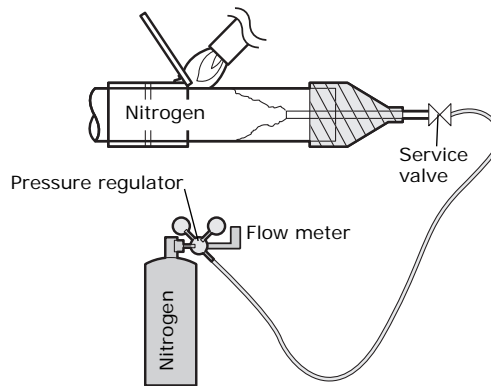
## Nitrogen Flushing While Brazing

**NOTICE**

**Avoid Unit Damage!**  
**Never braise pipe connections without performing nitrogen flushing. Failure to perform this procedure will damage the unit, resulting in capacity loss and reduced long-term reliability.**

While brazing refrigerant pipes, flush them with nitrogen gas. Use a pressure regulator to maintain a flow rate of 1.76 ft<sup>3</sup>/h (0.05 m<sup>3</sup>/h) or more.

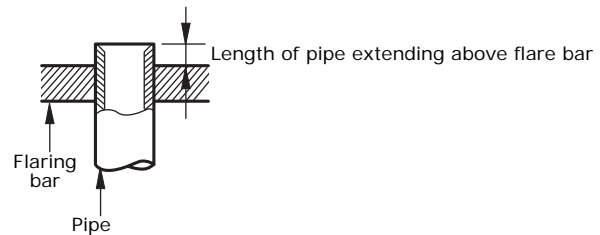
**Figure 13. Nitrogen flushing while brazing refrigerant pipes**


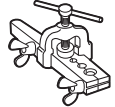


## Flared Pipe Connections

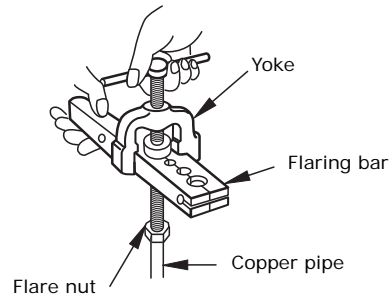
Clutch type and wing nut type flare tools are available for flared pipe connections.

1. Slide the flare nut over the pipe to be flared.
2. Slide the end of the pipe into the hole on the flaring bar that fits the pipe, leaving a length of pipe, determined by tool type (see table), extending above the flaring bar. Clamp it down.

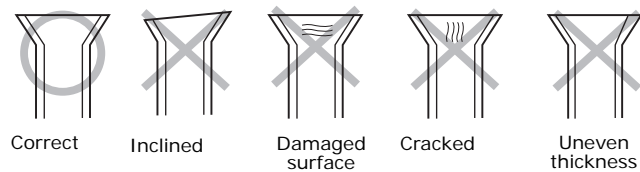


R-410A clutch type	Conventional flare tool	
	Clutch type	Wing nut type
0–1/32 in.	1/32–1/16 in.	1/16–13/16 in.
		

3. Attach the yoke to the flaring bar, centering the conical part over the end of the pipe that is extending above the flaring bar.
4. Tighten the yoke securely to flare the end of the pipe.



5. Remove the pipe. The end of the pipe that you flared should look like the end of a trumpet. See examples of correctly and incorrectly flared pipes.



6. Align the pipes and tighten the flare nuts manually and then with a spanner torque wrench, applying the torque according to pipe dimensions:

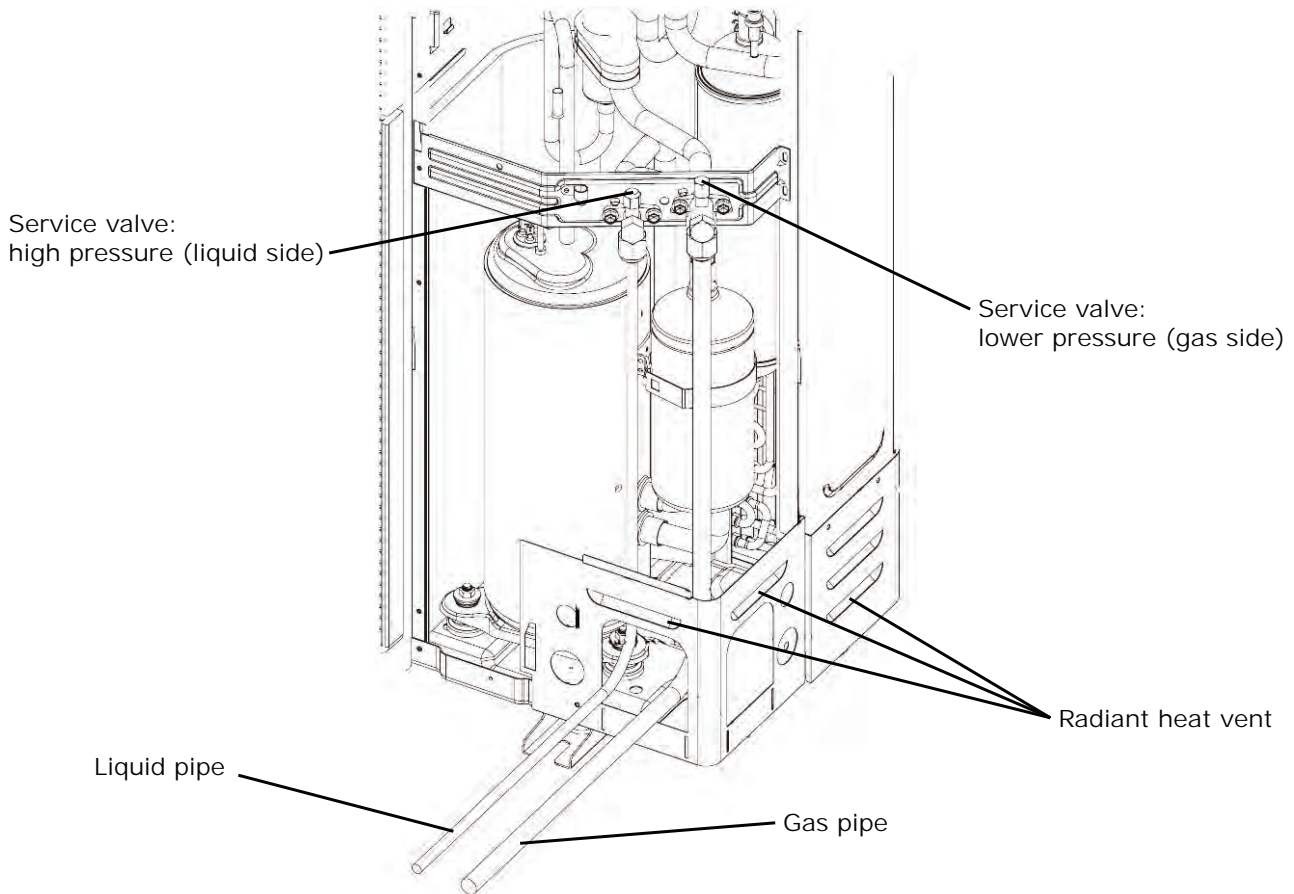
Outer diameter in.	Connection torque (ft·lb)	Flare dimension (in.)	Flare shape (in.)
1/4	10.3–13.3 ft·lb	3/8	
3/8	25.1–31.0 ft·lb	1/2	
1/2	36.1–45.0 ft·lb	5/8	
5/8	50.2–60.5 ft·lb	3/4	

### Connecting Piping to the Outdoor Unit

Pipes can be connected to the outdoor unit at the front, back, bottom, left, or right of the unit.

1. Remove the pipe cover from the unit. See [Figure 14](#).

**Figure 14. Pipe connections on unit**



2. Remove the knock-out that you are going to use, taking care to prevent damage to the exterior of the unit.
  - Remove burrs from knock-out hole edges and apply rust inhibitor.
  - Unused knock-outs should remain closed to prevent damage to the unit.
3. Connect the pipes to the unit using flared connections or by brazing. If brazing the pipe connection, avoid damaging the service valves by wrapping them with a wet cloth.
  - Avoid damaging the temperature sensor.
  - Ensure that the connected pipes do not touch each other or make contact with the unit.
  - Ensure that all pipe connections are accessible for servicing and maintenance.
4. After making electrical connections (see [“Electrical Wiring” p. 25](#)) and insulating the pipes (see [“Insulation” p. 35](#)), replace the pipe cover and close the remaining gap. Make sure the radiant heat vents ([Figure 14, p. 24](#)) are not blocked.



# Electrical Wiring

Observe the following precautions when making electrical connections. Refer to [Figure 15](#) for a typical system installation diagram.

## **⚠ WARNING**

### **Hazardous Voltage!**

**Disconnect all electric power, including remote disconnects before servicing. Follow proper lockout/tagout procedures to ensure the power can not be inadvertently energized. Failure to disconnect power before servicing could result in death or serious injury.**

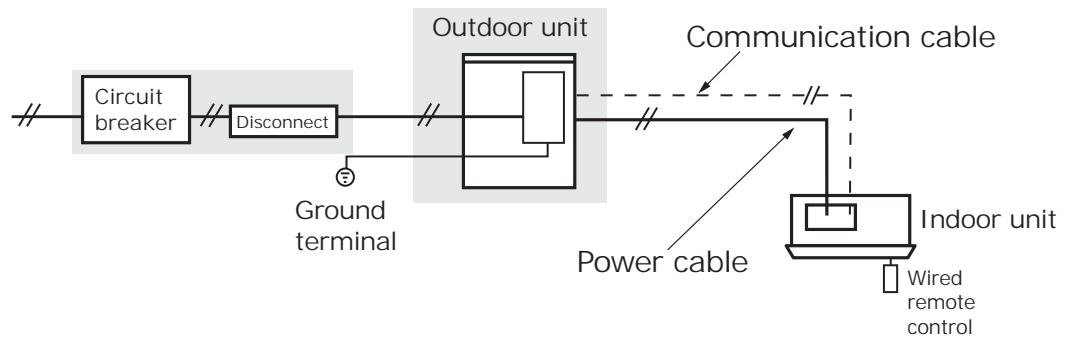
## **NOTICE**

### **Use Copper Conductors Only!**

**Unit terminals are not designed to accept other types of conductors. Failure to use copper conductors could result in equipment damage.**

- Make all electrical connections in accordance with electrical codes and ordinances.
- All wiring must be protected from weather and damage.
- Do not disconnect or change the factory wiring inside the unit.

**Figure 15. Typical system installation wiring**



## Power Wiring

- Multi-pole circuit breaker or disconnect is required to fully isolate the unit from all power.
- Install circuit breakers/disconnects in accordance with local and national codes.
- Select the power cable in accordance with relevant local and national regulations.
- Power cable specifications are based on an underground/ambient temperature of 86°F (30°C) and single multi-conductor cables. If conditions are different from these, consult an electrical installation expert and re-select the power cable. If the length of power cable exceeds 164 ft, re-select the power cable considering the voltage drop.
- Do not use power cable that has exposed wire.
- Unbalanced power must be maintained within 2% of supply rating among all indoor units or the unit will stop and an error code will be generated. (Significantly unbalanced power may shorten the life of the system.)
- Use a power cable made out of incombustible material for the insulator (inner cover) and the sheath (outer cover).

## Electrical Wiring

- Provide strain relief for power cables.

<b>⚠ WARNING</b>	
<b>Avoid Risk of Fire or Explosion!</b>	
Do not let the power cable come into contact with the pipes inside the outdoor unit. If the power supply cable touches the pipes, the vibration of the compressor will be transferred to the pipes and can damage the power supply cables or pipes. The damage could result in fire or explosion, causing death or serious injury.	

Follow these steps for wiring the outdoor unit:

1. Refer to [Table 9](#) for circuit breaker and power cable specifications.

**Table 9. Circuit breaker and power cable specifications**

Model		Power		RLA	FLA				MCA	MOP		
Outdoor	Indoor	Hz	V		Outdoor fan 1 (A)	Outdoor fan 2 (A)	Indoor fan 1 (A)	Indoor fan 2 (A)				
4TUK4512A10N0*	4MUW4512A10N0*	60	208–230	8.1	0.17	—	0.4	—	10.7	15		
4TUK4518A10N0*	4MUC4518A10N0*			6.1	0.13	—	0.13	—	0.33	—	10.0	15
	4MUD4518A10N0*								0.85	—		
	4MUS4518A10N0*								0.33	—		
	4MUW4518A10N0*								0.7	—		
	4MUM4518B10N0*								1.55	—		
	4MUD4518B10N0*								1.1	—		
4TUK4524A10N0*	4MUC4524A10N0*			9.0	0.48	—	0.48	—	0.33	—	14.0	20
	4MUD4524A10N0*								0.85	—		
	4MUS4524A10N0*								0.33	—		
	4MUW4524A10N0*								0.7	—		
	4MUM4524B10N0*								1.85	—		
	4MUD4524B10N0*								1.5	—		
4TUK4530A10N0*	4MUC4530A10N0*			15.1	0.48	—	0.48	—	0.35	—	24.0	30
	4MUD4530A10N0*	1.9	1.9									
	4MUS4530A10N0*	0.35	—									
	4MUW4530A10N0*	0.9	—									
	4MUM4530B10N0*	2.35	—									
	4MUD4530B10N0*	1.5	1.5									
4TUK4536A10N0*	4MUC4536A10N0*	17.0	0.48	0.48	0.48	0.48	0.35	—	26.5	35		
	4MUD4536A10N0*						1.9	1.9				
	4MUS4536A10N0*						0.35	—				
	4MUW4536A10N0*						0.9	—				
	4MUM4536B10N0*						4.15	—				
	4MUD4536B10N0*						2	2				
4TUK4542A10N0*	4MUC4542A10N0*	17.0	0.48	0.48	0.48	0.48	0.35	—	26.5	35		
	4MUD4542A10N0*						1.9	1.9				
	4MUS4542A10N0*						0.35	—				
	4MUM4542B10N0*						4.15	—				
	4MUD4542B10N0*						2	2				
	4TUK4548A10N0*						4MUC4548A10N0*	17.0			0.48	0.48
4MUD4548A10N0*		1.9	1.9									
4MUS4548A10N0*		0.35	—									
4MUM4548B10N0*		4.15	—									
4MUD4548B10N0*		2	2									

**Notes:**

- Voltage tolerance is  $\pm 2\%$ .
- RLA: Rated load ampere; FLA: Full load ampere; MCA: Minimum circuit amperes; MOP: Maximum overcurrent protective device (amperes).

- Cut the power cable to an appropriate length and connect it to terminals L1 and L2 in the power supply box with a solderless ring terminal (see Figure 16).

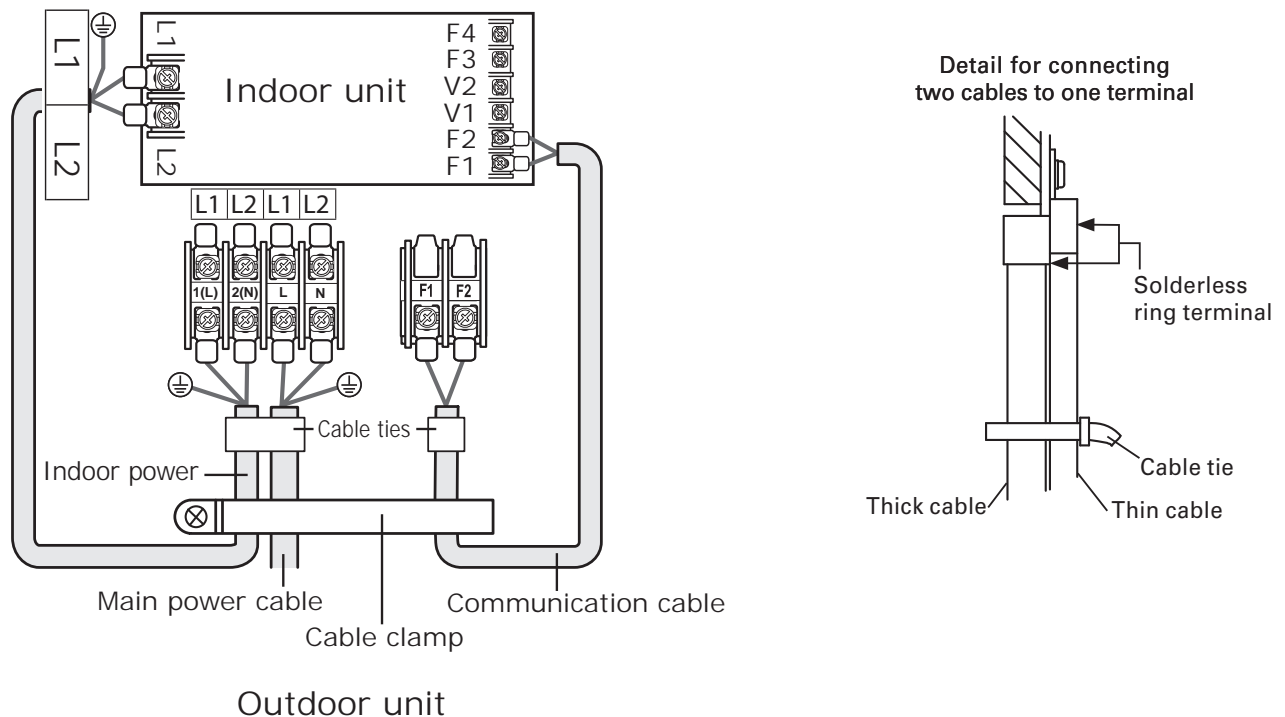
Unit capacity	Screw	Tightening torque for terminal	Terminals
12, 18 MBH	M4	0.9–1.3 lbf/ft	AC power: L1, L2 and Communication: F1, F2
24, 30, 36, 42, 48 MBH	M3	0.4–0.5 lbf/ft	Communication: F1, F2
	M5	1.5–2.2 lbf/ft	AC power: L1, L2

- If two cables are connected to one terminal, place the cables back to back with the thin cable upward and the thick cable downward, as shown in the detail in Figure 16.
- Secure the cable(s) with a cable tie and provide strain relief.
- Replace the cover on the terminal board.

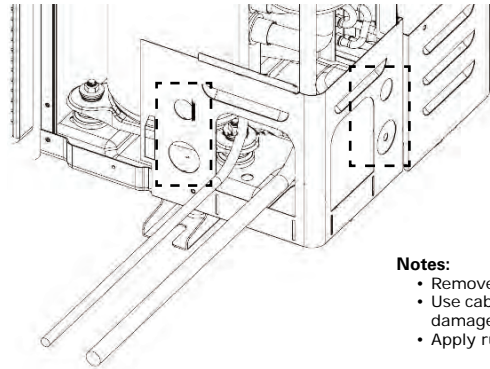
**Note:** Make sure that the section of the power supply cable that has the sheath removed is inside the power supply box. If this is not possible, connect the power cable conduit to the power supply box.

- Pull the power cable through one of the designated knock-outs at the bottom right of the outdoor unit (refer to Figure 17, p. 28).

**Figure 16. Power wiring terminals**



**Figure 17. Power cable knock-outs**



**Notes:**

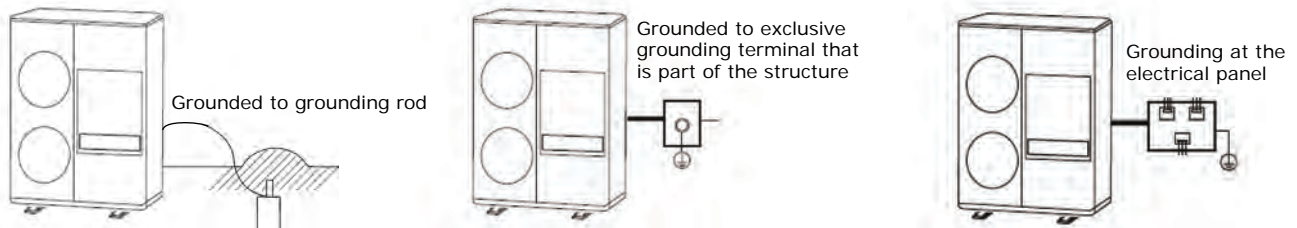
- Remove burrs from the knock-out hole.
- Use cable conduit and bushing to prevent cables from being damaged when passing through the knock-out holes.
- Apply rust-resistant paint around the knock-out hole.

## Grounding

**Important:** Grounding must be done by a qualified electrician. The unit cannot be ground by a gas or water pipe, a lightning rod, or a telephone line grounding wire.

Ground the unit at an exclusive grounding terminal, at the electrical panel (see [Figure 18](#)), or to a grounding rod if the power distribution circuit is not grounded or its grounding does not comply with electrical codes and specifications.

**Figure 18. Outdoor unit grounding examples**



## Installing a Grounding Rod

If the installation requires a grounding rod is required, follow this procedure:

1. Select a grounding rod that complies with national and local codes.
2. Select a location for the grounding rod that:
  - Contains hard damp soil rather than loose sand or gravel.
  - Is located away from underground structures such as gas and water pipes, telephone lines, and underground cables.
  - Is at least 6-1/2 ft away from a lightning conductor.
3. Install the grounding rod in accordance with national and local codes.
4. Proceed with "[Installing the Grounding Cable.](#)"

## Installing the Grounding Cable

1. Select rated grounding cable by referring to the outdoor unit power cable specifications ([Table 9, p. 26](#)).
2. Connect the grounding cable to the grounding hole inside the power supply box and pull it through the designated grounding knock-out.

**Note:** If the grounding cable length needs to be extended, make the cable connection in accordance with national and local codes.

3. If a grounding rod was installed to ground the unit, measure the resistance with a ground resistance tester. Refer to [Table 10](#) for resistance requirements.
  - If the resistance is above the requirements, drive the grounding rod deeper into the ground or increase the number of grounding rods until the resistance requirement is achieved.
  - If you have grounded the unit to a grounding terminal or electrical panel, ensure that the resistance meets the requirements.

**Table 10. Grounding resistance requirements**

Power condition at installation site	High or average humidity	Low humidity
Voltage to ground is $\leq 150$ V	<ul style="list-style-type: none"> <li>• Ensure that the grounding resistance is <math>&lt; 100 \Omega</math>.</li> <li>• If a circuit breaker is installed that disconnects the circuit within 0.5 second, the allowable grounding resistance is <math>30\text{--}500 \Omega</math>.</li> </ul>	<ul style="list-style-type: none"> <li>• Ideally, grounding resistance should be <math>&lt; 100 \Omega</math>, and should not exceed <math>250 \Omega</math>.</li> </ul>
Voltage to ground is $> 150$ V		<ul style="list-style-type: none"> <li>• Ensure that the grounding resistance is <math>&lt; 100 \Omega</math>.</li> <li>• If a circuit breaker is installed that disconnects the circuit within 0.5 second, the allowable grounding resistance is <math>30\text{--}500 \Omega</math>.</li> </ul>

## Communications Wiring

Use 18 AWG, 25 pF/ft nom., 60.7  $\Omega$  impedance, braid or foil shielded, twisted pair wire for communications wiring.

### ⚠ WARNING

#### Hazardous Voltage!

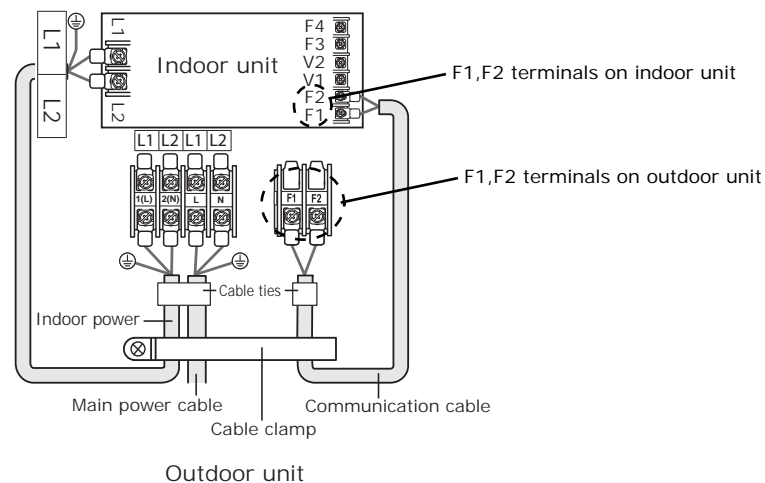
Disconnect all electric power, including remote disconnects before servicing. Follow proper lockout/tagout procedures to ensure the power can not be inadvertently energized. Failure to disconnect power before servicing could result in death or serious injury.

1. Connect the communications cable wires to terminals F1 and F2, as shown in [Figure 19](#).

#### Notes:

- Ensure that more than 1 in. of the outer sheath of the power and communication cable conduit are inside the electrical component box.
- To reduce interference, ensure that power and communication cables run in parallel with a minimum space of 2 in. between the cables or, if crossing is necessary, cross at 90 degrees.
- The communication cable between outdoor units and between indoor and outdoor units has no polarity.

**Figure 19. Wiring terminals for communication between indoor and outdoor units**



2. Provide strain relief for the communications cable.
3. Pull the communications cable through the designated knock-out at the bottom right of the outdoor unit (refer to [Figure 17, p. 28](#)).

# System Leak Testing Procedure

Before leak testing pipe connections, read all safety precautions and notes.

## WARNING

### Confined Space Hazards!

Do not work in confined spaces where refrigerant or other hazardous, toxic or flammable gas may be leaking. Refrigerant or other gases could displace available oxygen to breathe, causing possible asphyxiation or other serious health risks. Some gases may be flammable and or explosive. If a leak in such spaces is detected, evacuate the area immediately and contact the proper rescue or response authority. Failure to take appropriate precautions or to react properly to such potential hazards could result in death or serious injury.

## WARNING

### Explosion Hazard!

Never use an open flame to detect gas leaks. It could result in an explosion. Use a leak test solution for leak testing. Failure to follow recommended safe leak test procedures could result in death or serious injury or equipment or property-only-damage.

Use only dry nitrogen with a pressure regulator for pressurizing unit. Do not use acetylene, oxygen or compressed air or mixtures containing them for pressure testing. Do not use mixtures of a hydrogen containing refrigerant and air above atmospheric pressure for pressure testing as they may become flammable and could result in an explosion. Refrigerant, when used as a trace gas should only be mixed with dry nitrogen for pressurizing units. Failure to follow these recommendations could result in death or serious injury or equipment or property-only damage.

Do not exceed unit nameplate design pressures when performing a leak test. Failure to follow these instructions could result in an explosion causing death or serious injury.

### Notes:

- All required piping pressure tests must be completed in accordance with national and/or local codes.
- When leak-testing refrigerant systems, observe all safety precautions.
- Leak test only one circuit at a time to minimize system exposure to potentially harmful moisture in the air.
- Use R-410A refrigerant gas as a tracer for leak detection and use oil-pumped dry nitrogen to develop required test pressures.
- Use tools rated for R-410A.
- Do not remove the valve core of the charging port.
- Perform the leak test with the outdoor unit service valves closed.

## System Leak Testing Procedure

Use the following procedure for leak testing pipe connections.

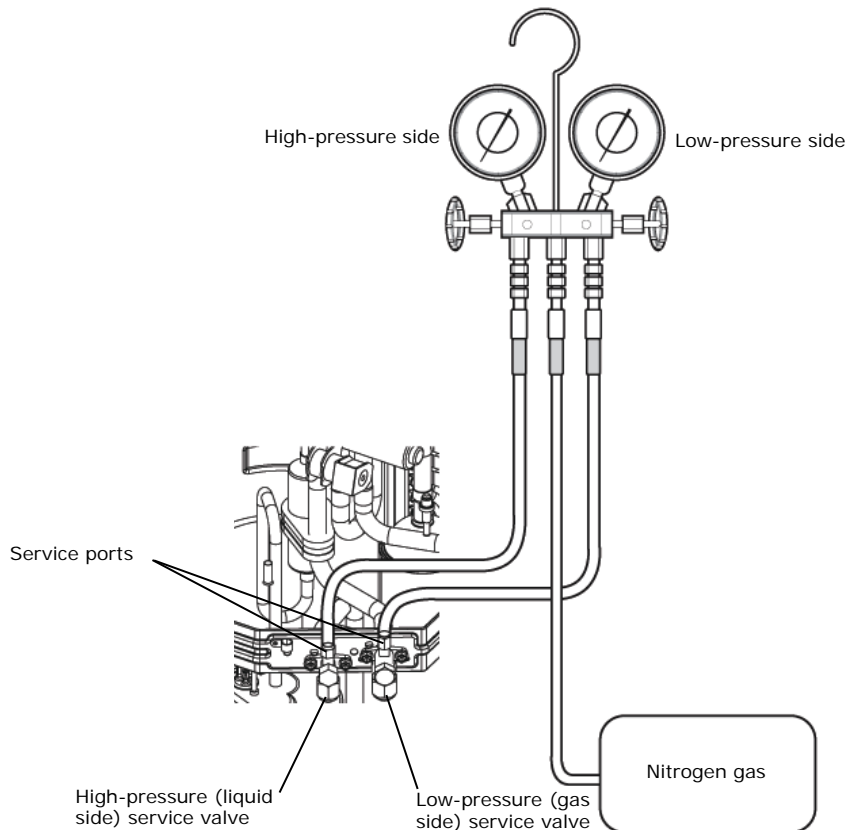
### NOTICE

#### Refrigerant Pipe Damage!

When performing a leak test, use a pressure regulator to prevent an excess amount of nitrogen (over 594.6 psi) from entering the pipes. If the pipe is filled with more than the specified amount of nitrogen in a short period of time, pipe damage may occur.

1. Connect the refrigerant manifold gauge hoses to the liquid side and gas side service ports on the unit, and connect the center hose to a nitrogen gas tank fitted with a pressure regulator (see Figure 20).

Figure 20. Leak testing pipe connections with a manifold gauge



2. Fill the lines with nitrogen to no more than 594.6 psi.
3. Monitor the pressure periodically for a minimum of 24 hours. If the pressure drops, use soapy water to check for leaks. Bubbles will occur if joints are not tight.
4. Release pressure in pipelines gradually.
5. Repair leaks.
6. Repeat the previous steps until the pressure remains constant.
7. Maintain 145 psi of pressure for 15 minutes and check for further leakage. If the pressure drops, check for leaks and repair them. Repeat this step as necessary until 145 psi of pressure is maintained for 15 minutes.
8. Remove hoses from service ports.

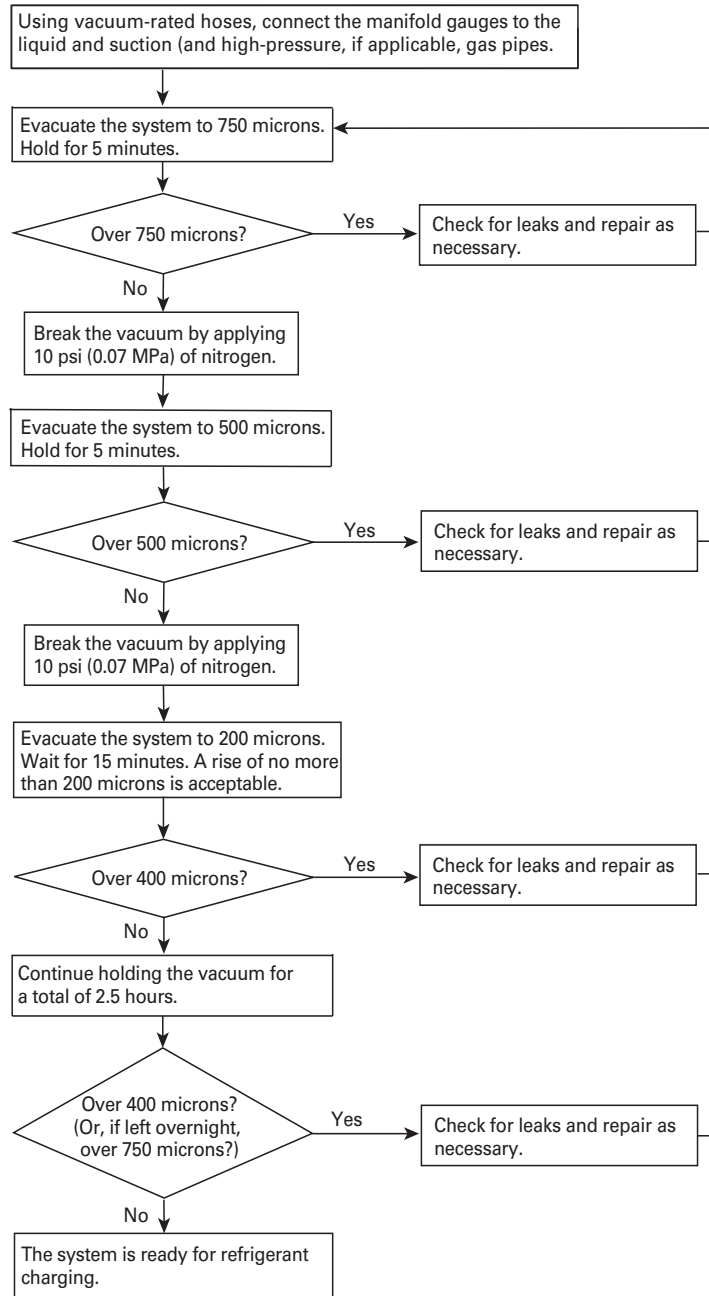


# System Evacuation Procedure

After performing a leak test, use a vacuum pump to triple evacuate the system as described in the following flow chart:

**Notes:**

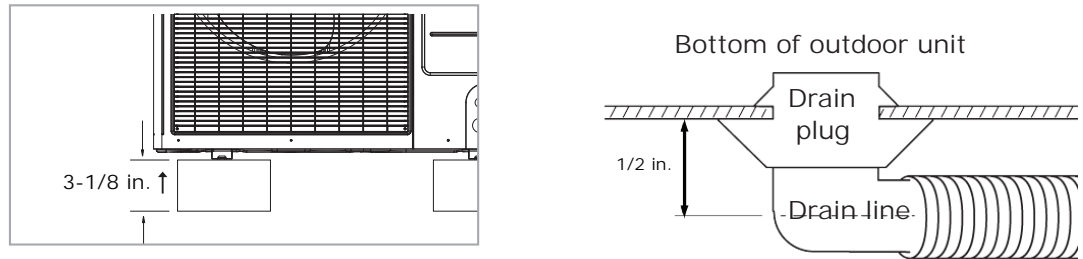
- Use a vacuum pump with a check valve to prevent pump oil from flowing backward while the vacuum pump is closed.
- Completely close the liquid-gas side service valve of the outdoor unit.



# Connecting the Drain Line

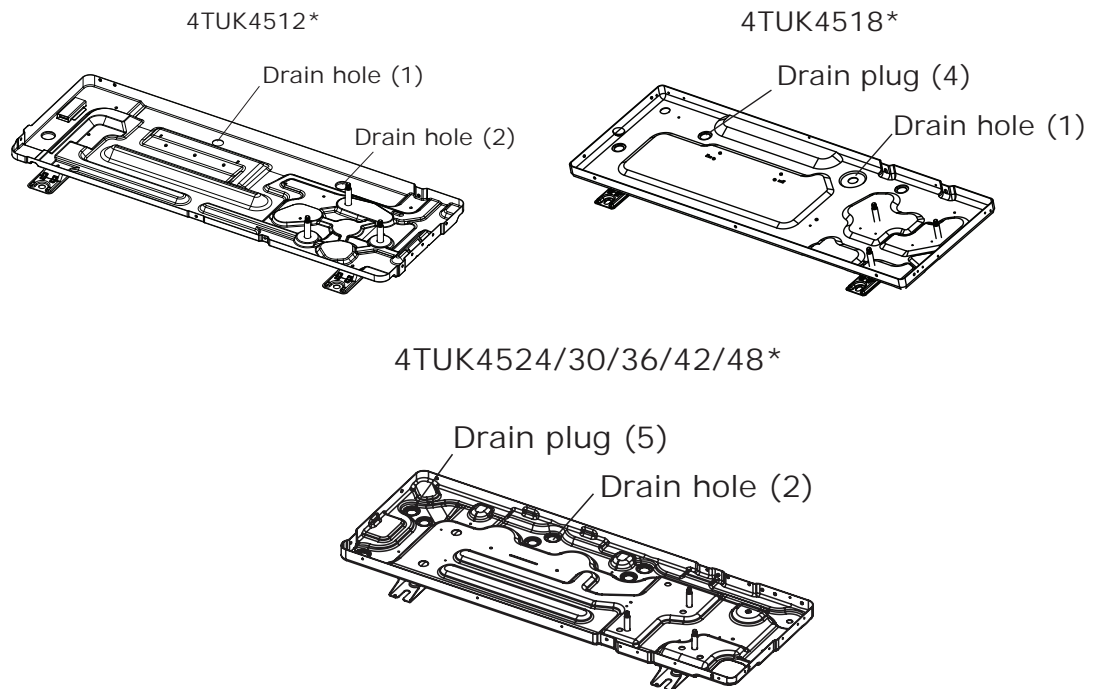
Condensed water must be safely drained away from the unit through a drain line.

**Note:** A minimum space of 2 in. must be allowed between the bottom of the outdoor unit and the supporting base to facilitate drain line installation.



To install the drain line:

1. Insert the drain connector into the drain hole on the underside of the outdoor unit.
2. Connect the drain line to the drain connector.
3. Plug the unused drain holes with drain plugs.



# Insulation

After determining that there are no leaks in the refrigerant pipes or drainage hose, insulate them as described in these sections.

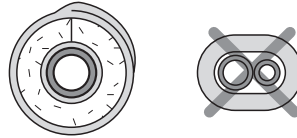
## Insulating Refrigerant Piping

- Use the table below to select the insulation thickness according to pipe size and humidity conditions.

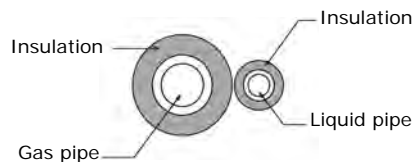
Pipe	Pipe size (in.)	Insulation Type, EPDM or NBR (in.)	
		Standard conditions (86°F [30°C], < 85%)	High humidity conditions <sup>(a)</sup> (86°F [30°C], ≥ 85%)
Liquid pipe	1/4–3/8	3/8 (9)	3/8 (9)
	1/2–2	1/2 (13)	1/2 (13)
Gas pipe <sup>(b)</sup>	1/4	1/2 (13)	3/4 (19)
	3/8	3/4 (19)	1.0 (25)
	1/2		
	5/8		
	3/4		

- (a) When installing insulation in any of the following environments, use insulation required for high humidity conditions: Buildings with close proximity to bodies of water or hot springs or on the side of a hill in which the building is partly covered by earth; ceilings frequently exposed to moisture such as in restaurants, saunas, swimming pools, and corridors of dormitories or studios near a frequently used outdoor exit; buildings with no ventilation system.
- (b) Internal temperature of gas pipe is higher than 248°F (120°C).

- Wrap insulation around the entire surface of each pipe, including the refrigerant pipes from the indoor unit to the service valves inside the outdoor unit, the branch joints, distribution header, and connection points on each pipe.
  - Do not wrap the gas and liquid refrigerant pipes together.



- If gas and liquid pipes are in contact with one another, use thicker insulation and make sure the pipes are not pressing tightly against one another.



- Overlap insulation to avoid gaps.
- Avoid compressing the insulation as much as possible.
- Be sure there are no cracks or deformities in the insulation at bends in pipes or where hangers are attached to pipes.
- If necessary, double the insulation to prevent condensation from forming in warm or humid areas.

## Insulating the Drain Line

Insulate (field supplied) the entire surface of the drain pipe that is inside the building, including the connection between the drain line and drain stub. Clamp tightly.

# Refrigerant

After successful leak testing and vacuum drying, calculate the amount of refrigerant needed and then charge the system, as specified in this section.

## Calculating the Refrigerant

The unit is shipped from the factory with the refrigerant holding charge given in [Table 11](#).

Refer to [Table 12](#) for the additional refrigerant charge quantity.

**Table 11. Refrigerant holding charge for each outdoor unit model**

	Model						
	4TUK4512*	4TUK4518*	4TUK4524*	4TUK4530*	4TUK4536*	4TUK4542*	4TUK4548*
Refrigerant holding charge (lb)	2.31	2.87	4.63	5.73	6.17	6.17	6.17
<b>Note:</b> The holding charge amount takes into account the indoor unit and 25 ft of pipe.							

**Table 12. Total additional refrigerant charge for each outdoor unit model**

	Model						
	4TUK4512*	4TUK4518*	4TUK4524*	4TUK4530*	4TUK4536*	4TUK4542*	4TUK4548*
Additional refrigerant charge (oz/ft)	0.11			0.24	0.35		

## Charging the Refrigerant

After calculating the correct amount of refrigerant needed by the system (see [“Calculating the Refrigerant”](#) p. 36), charge the system as described in the following procedure:

### ⚠ WARNING

#### Hazard of Explosion and Deadly Gases!

Do not heat the refrigerant container to speed up the charging process. An explosion could result, resulting in death or serious injury.

### NOTICE

#### Risk of Unit Malfunction!

Do not leave the front panel open while charging refrigerant. If the front panel is open, the amount charged into the unit will be incorrect.

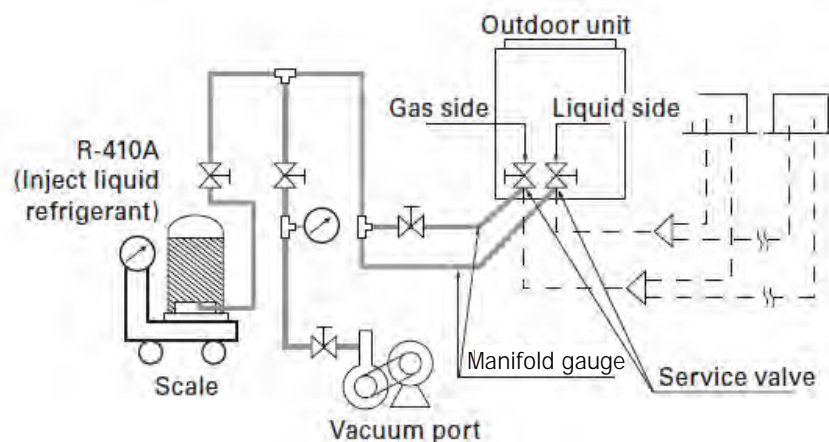
### NOTICE

#### Unit Component Damage!

Open the gas side and liquid side service valves completely after charging the refrigerant. If you operate the unit with the service valves closed, the unit may be damaged.

1. Attach the liquid manifold hose to the liquid side service port and open the manifold gauge valve.
2. Add the liquid refrigerant, making sure the refrigerant bottle is held in an upright position. Use a scale to determine that the correct amount has been added.
3. Close the refrigerant container immediately after adding the refrigerant.

**Figure 21. Charging additional refrigerant**



4. Open the outdoor unit service valves to release the charge from the outdoor unit.
5. After charging the refrigerant, replace the caps.

# Control System

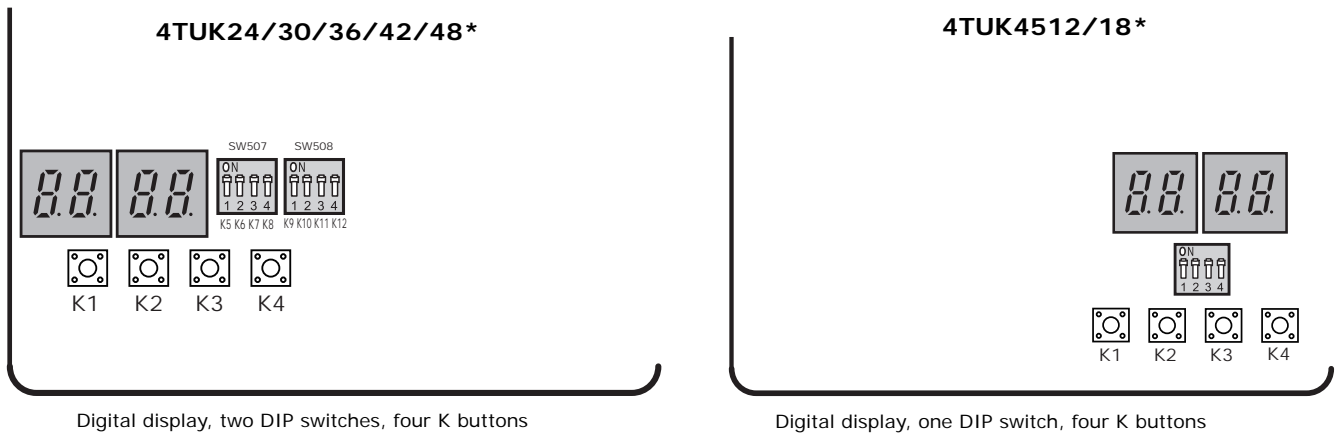
The functions of the digital display, DIP switches, and K buttons are explained in this section. Refer to [Figure 22](#) for how their location on the control board.

**⚠ WARNING**

**Hazardous Voltage!**

Before making contact with the inverter circuit board, wait for at least 15 minutes after powering down the outdoor unit to allow the unit to fully discharge high DC voltage. Failure to allow the high DC voltage to discharge completely could result in death or serious injury.

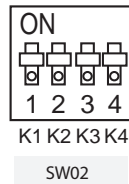
Figure 22. Location of the digital display, DIP switches, and K buttons on control board



## Configuring the System

### Model 4TUK4512/18\*

Units with a capacity of 18 MBH have a control board with one DIP switch (Figure 22 shows its location). DIP switch configurations are explained in Table 13.



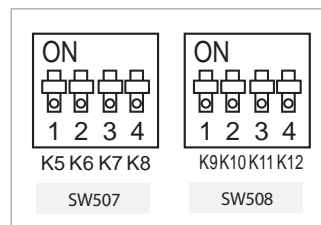
**Table 13. Model 4TUK4518: DIP switch SW02 (K1–K4)**

DIP switch	Setting	Function description
<b>Snow prevention control</b>		
K1	On	Disables snow prevention control (default)
	Off	Enables snow prevention control <sup>(a)</sup>
<b>Silence mode control</b>		
K3	On	Disable silence mode option
K4	On	
K3	On	Silence mode 1st step
K4	Off	
K3	Off	Silence mode 2nd step
K4	On	
K3	Off	Silence mode 3rd step
K4	Off	

(a) When snow prevention control is enabled, eco mode (standby mode) is not functional.

### Models 4TUK4524/30/36/42/48

Units with a capacity of 24/30/36/42/48 MBH have a control board with two DIP switches (Figure 22 shows their locations). DIP switch configurations are explained in Table 15 and Table 14.



**Table 14. Model 4TUK4524/30/36/42/48: DIP switch SW508 (K9–K12)**

SW508	On (default)	Off
K9	Auto Silence Mode <sup>(a)</sup>	Manual Silence Mode <sup>(b)</sup>
K10	Not used.	
K11		
K12		

(a) Auto Silence Mode requires a locally purchased time relay, which enables remote control of this function.  
 (b) Manual Silence Mode requires further configuration using DIP switch SW507 (see Table 15).

**Table 15. Model 4TUK4524/30/36/42/48: DIP switch SW507 (K5–K8)**

SW507	Setting	Function description
<b>Snow prevention control</b>		
K6	On	Disables snow prevention control (default)
	Off	Enables snow prevention control <sup>(a)</sup>
<b>Silence mode control (for manual function; see Table 14)</b>		
K7	On	Disable silence mode option
K8	On	
K7	On	Silence mode 1st step
K8	Off	
K7	Off	Silence mode 2nd step
K8	On	
K7	Off	Silence mode 3rd step
K8	Off	

(a) When snow prevention control is enabled, Eco mode (standby mode) is not functional.



## Monitoring System Settings

Button K4 is pushed once to view system settings, as described in [Table 16](#)

**Table 16. Button K4: System settings**

Number of times button K4 is pressed	Setting	Digital display				Unit
		Digit 1	Digit 2	Digit 3	Digit 4	
1	Order frequency	1	Hundreds' digit	Tens' digit	Ones' digit	Hz
2	Current frequency	2	Hundreds' digit	Tens' digit	Ones' digit	Hz
3	Number of connected indoor units	3	0	0	1	Each
4	Sensor for outdoor intake	4	±	Tens' digit	Ones' digit	°C
5	Discharge sensor	5	Hundreds' digit	Tens' digit	Ones' digit	°C
6	Eva-Mid sensor	6	±	Tens' digit	Ones' digit	°C
7	Condensate sensor	7	±	Tens' digit	Ones' digit	°C
8	Current	8	Tens' digit	Ones' digit	Tenths' digit (decimal)	A
9	Fan speed	9	Thousands' digit	Hundreds' digit	Tens' digit	rpm
10	Target discharge sensor	A	Hundreds' digit	Tens' digit	Ones' digit	°C
11	MAIN EEV	B	Hundreds' digit	Tens' digit	Ones' digit	step
12	Capacity sum of indoor units	C	Tens' digit	Ones' digit	Tenths' digit (decimal)	kW
13	Protective control	D	0: Cooling 1: Heating	Protective control 0: No protective control 1: Freezing 2: Non-stop defrosting 3: Overload 4: Discharge 5: Total electric current	Frequency status 0: Normal 1: Hold 2: Down 3: Up limit 4: Down limit	—
14	Temperature of heat radiating plate	E	Hundreds' digit	Tens' digit	Ones' digit	—
15	Software version	F	—	—	—	—

## Control System

Button K4 is pushed in sequence to view software versions and unit addresses, as described in [Table 17](#).

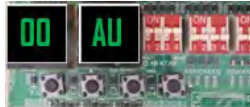



**Table 17. Button K4: Software versions and unit addresses**

Button K4 is pressed in sequence (number of times)	Software version/ Unit address	Digital display			
		Digit 1: Year (Hex)	Digit 2: Month (Hex)	Digit 3: Date (Tens' digit)	Digit 4: Date (Ones' digit)
1, and held 3 seconds	Main circuit board version				
1	Inverter board version				
1	EEPROM version				
		Digit 1	Digit 2	Digit 3	Digit 4
1	Automatically assigned unit addresses	A	0	0	1
1	Manually assigned unit addresses	A	0	0	1

## Changing an Outdoor Unit Address

If multiple outdoor units are connected to a VRF System Controller or a VRF Touchscreen, it may be necessary to manually address the outdoor units. Addresses available for outdoor units range from 00 to 15. Refer to [Table 18](#).

**Table 18. Address change for multiple outdoor units using a VRF System Controller or a VRF Touchscreen**

Button K2 action	Operation	Display view
Press <b>K2</b> and hold for 2 seconds	Displays outdoor unit address. If auto addressed, <b>00 AU</b> will appear.	
	If manually addressed, the display will show <b>00 00</b> through <b>00 15</b> . The example in the next column shows that the address was manually set to <b>03</b> .	
Press and release <b>K2</b> repeatedly	Cycles through OD unit addresses: <b>00 00, 00 01, 00 02, . . . 00 15</b> , then back to <b>00 AU</b> .	
Press <b>K2</b> and hold until display flashes and relays click.	Saves the address that appears on the display. The example in the next column shows that the address was manually set to <b>02</b> .	

**Notes:**

- To exit without saving, press and release **K1**.
- After saving the address setting, wait at least 3 minutes before starting the system
- After the manually set address is saved, the display will begin scrolling through the indoor unit addresses.

# Pre-Start Checks

After installation and before the test operation is conducted, perform the following pre-start checks:

<b>NOTICE</b>
<b>Avoid Damage to the Communication Circuit!</b>
<b>Do not measure the communication terminal with an insulation tester. Doing so will damage the communication circuit.</b>

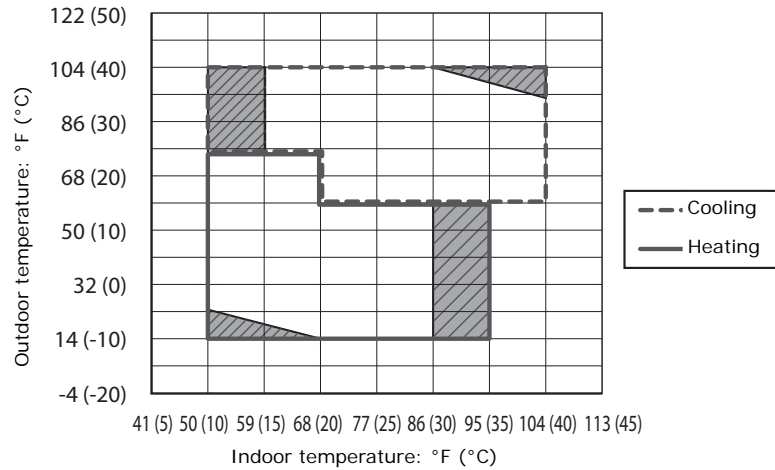
- Ensure that the auxiliary circuit breaker is providing power to the outdoor unit: 1-phase power supply (L1,L2).
- Ensure that the thermistor sensor, drain pump and hose, and wireless receiver are correctly connected.
- Ensure that the power and communication cables of the indoor and outdoor units are properly connected.
- Before supplying power, use a resistance tester to verify that resistance to ground is greater than 30 MΩ .
- Ensure that the indoor unit is connected.
- Check for a short-circuit between the communication terminal and ground.
- Ensure that the pre-start checklist (Table 19) has been completed.

**Table 19. Pre-start checklist**

<b>Installation</b>	<b>Outdoor unit</b>	<ul style="list-style-type: none"> <li>• Have you checked the external surface and the inside of the unit for damage?</li> <li>• Is there any possibility of short circuit due to the heat produced by the outdoor unit?</li> <li>• Is the place well-ventilated and meets recommended requirements for clearances and service?</li> <li>• Is the outdoor unit installed securely to withstand external forces?</li> </ul>
	<b>Indoor unit</b>	<ul style="list-style-type: none"> <li>• Have you checked the external surface and the inside of the indoor unit?</li> <li>• Is there enough space for service?</li> <li>• Have you ensured that the center of the indoor unit is installed horizontally and is level?</li> </ul>
<b>Refrigerant pipe</b>		<ul style="list-style-type: none"> <li>• Have you selected the correct pipes?</li> <li>• Are the liquid and gas valve open?</li> <li>• Is the total number of connected indoor units within the allowable range?</li> <li>• Are the length and the height difference between the refrigerant pipes within the allowable range?</li> <li>• Has the connection of liquid and gas pipes been correctly performed?</li> <li>• Have you selected correct insulator for pipes and insulated them correctly?</li> <li>• Is the pipe or connection part properly insulated?</li> <li>• Is the quantity of the additional refrigerant correctly weighed in? (You must record the amount of additional refrigerant charging on the service record paper placed outside the outdoor unit.)</li> </ul>
<b>Drain pipe</b>		<ul style="list-style-type: none"> <li>• Have you checked whether the drain pipes of the indoor unit and outdoor unit are connected together?</li> <li>• Have you completed the drain test?</li> <li>• Is the drain pipe properly insulated?</li> </ul>
<b>Electrical</b>		<ul style="list-style-type: none"> <li>• Are the power cable and communication cable tightened firmly on the terminal board within the rated torque recommendations?</li> <li>• Have you checked for cross connection of the power and communication cables?</li> <li>• Have the outdoor unit been properly grounded?</li> <li>• Is the communication cable shielded?</li> <li>• Is the wire length within the recommended limit?</li> <li>• Is the wiring route correct?</li> </ul>
<b>Setting address</b>		<ul style="list-style-type: none"> <li>• Are the address of the indoor and outdoor units properly set?</li> <li>• Are the address of the indoor and outdoor units properly set, if multiple remote controllers are to be used?</li> </ul>
<b>Option</b>		<ul style="list-style-type: none"> <li>• Ensure that the vibration-isolation structure is correctly installed or if one needs to be installed.</li> </ul>

# Test Operation

After all pre-start checks (refer to “Pre-Start Checks” p. 43) have been completed, run the test operation under the following conditions:



**Notes:**

- Within the temperature range marked with hashed lines, system protection control may trigger during the test operation. If this occurs, test results may be inaccurate.
- If the unit responds to outdoor conditions by operating in defrost mode, test results may be inaccurate.
- If the temperature is outside of the guaranteed range, test accuracy may decrease to the borderline area shown in the graph.

**⚠ WARNING**

**Hazardous Voltage, Rotating Components!**  
 Do not operate the product with the panel or duct outlet protection net off. There is risk of personal injury from parts that rotate or contain high voltage.

**⚠ CAUTION**

**Risk of Burn or Frostbite!**  
 Refrigerant pipe may be hot or cold during or right after the operation depending on the status of the refrigerant which flows through the refrigerant pipe, compressor, and other parts of the refrigerant cycle. Do not touch the refrigerant pipe during or immediately after the operation to avoid getting burned or frostbitten.



**NOTICE**

**Avoid Unit Damage!**  
 Wait at least 5 minutes before turning off the main power after the test operation is finished. If you do not, water leakage or other problems may occur.  
 Wait at least 3 hours after power is supplied to the outdoor unit before operating it to allow time for the crank case heater to pre-heat. If the crank case heater is not pre-heated before operation, unit parts are at risk of being seriously damaged.




1. Before powering the unit, heed the precautions given above for the test operation.  
*Note: When power is supplied to the outdoor unit, it will check for and verify communications with the indoor unit.*
2. Ensure that the front of the outdoor unit is closed.

3. Press buttons K1 or K2 to run the test operation as described in the [Table 20, p. 45](#) and [Table 21, p. 45](#).
4. The first two digits of the digital display respond as shown in the last column of the tables.

**Table 20. Button K1**

	Operation	Digital display: Digits 1 and 2
1	Heating test mode	
2	Defrost test mode	

**Table 21. Button K2**

	Operation	Digital display: Digits 1 and 2
1	Cooling test mode	
2	Inverter check function (load control board inspection operation).	
3	Pump down in cooling mode	

5. After 12 minutes of stable operation, check the following:
  - Cooling mode (indoor unit check): Inlet air temperature–outlet air temperature  $\geq 18^{\circ}\text{F}$  ( $-7.8^{\circ}\text{C}$ ) (reference only)
  - Heating mode (indoor unit check): Inlet air temperature–outlet air temperature  $\geq 19.8^{\circ}\text{F}$  ( $-6.8^{\circ}\text{C}$ ) (reference only)
  - In heating mode, the indoor fan motor can remain off to avoiding blowing cold air into the heated space.
6. Press the K3 button for more than 1 second to reset the outdoor unit power supply, to deactivate test mode, or to reset an error code.

# Service: Pump Down Procedure

## ⚠ WARNING

### Refrigerant under High Pressure!

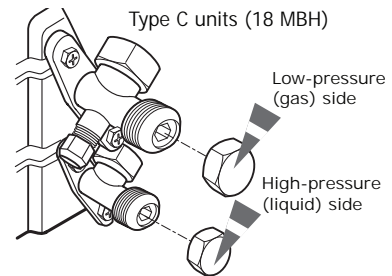
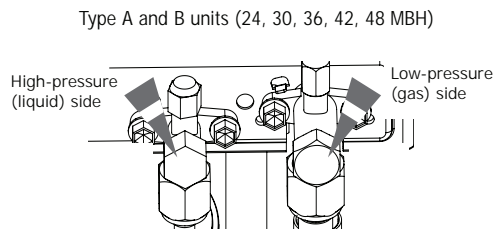
Failure to follow code concerning could result in an explosion which could result in death or serious injury or equipment damage. The refrigerant container used to collect refrigerant from the system must be one that is exclusively designed for that purpose.

## NOTICE

### Equipment Damage!

Do not allow the amount of system refrigerant that is pulled into the outdoor unit during the pump down process to exceed the capacity of the outdoor unit or equipment damage may occur.

1. Remove the cap from the low pressure side.



2. Close the gas side service valve, connect a manifold gauge to the valve, and open the valve again.
3. Press the K2 button once on the outdoor unit control board to set the unit to the cooling test mode. (Make sure the compressor is running.)
4. Close the liquid side service valve.
5. When the manifold gauge indicates that the pressure is lower than 0 psig (0 MPa), close the gas side service valve.
6. Press the K3 button once to reset the system and stop the pump down procedure.
7. Remove the manifold gauge.
8. Cap each valve.

## Relocating the Outdoor Unit

If the outdoor unit is to be moved to a different location, follow this procedure:

1. Perform the pump down procedure ([“Service: Pump Down Procedure” p. 46](#)).
2. Remove the power cord.
3. Disconnect the assembly cable from the indoor and outdoor units.
4. Remove the flare nut that connects the indoor unit to the refrigerant pipe and disconnect them.
5. Cap or plug the disconnected pipes to keep foreign matter out of them.
6. Disconnect the refrigerant pipe from the outdoor unit.
7. Cap or plug the disconnected pipes to keep foreign matter out of them.
8. Store the connection pipes with the cables, making sure you do not bend the pipes.
9. Move the indoor and outdoor units to the new location.
10. Remove the mounting plate for the indoor unit and move it to a new location.



Ingersoll Rand (NYSE:IR) advances the quality of life by creating comfortable, sustainable and efficient environments. Our people and our family of brands—including Club Car®, Ingersoll Rand®, Thermo King® and Trane®—work together to enhance the quality and comfort of air in homes and buildings; transport and protect food and perishables; and increase industrial productivity and efficiency. We are a global business committed to a world of sustainable progress and enduring results.



[ingersollrand.com](http://ingersollrand.com)

Ingersoll Rand has a policy of continuous product and product data improvement and reserves the right to change design and specifications without notice.  
We are committed to using environmentally conscious print practices.