



Installation Instructions

Packaged Rooftop Air Conditioners IntelliPak 1 4 to 1 (Full) and Limited Modulation Gas Heat Actuator and Auxiliary Switch for 20 to 130 Tons

Model Number:
X13611434010 or ACT00672/Trane Actuator
X13612070001 or SWT04018/Trane Auxiliary Switch

Used With:
S*HL, S*HK

SAFETY WARNING
Only qualified personnel should install and service the equipment. The installation, starting up, and servicing of heating, ventilating, and air-conditioning equipment can be hazardous and requires specific knowledge and training. Improperly installed, adjusted or altered equipment by an unqualified person could result in death or serious injury. When working on the equipment, observe all precautions in the literature and on the tags, stickers, and labels that are attached to the equipment.

March 2018 RT-SVN026B-EN © 2018 Ingersoll Rand

1 Warnings, Cautions, and Notices

Read this manual thoroughly before operating or servicing this unit. Safety advisories appear throughout this manual as required. Your personal safety and the proper operation of this machine depend upon the strict observance of these precautions.

- The three types of advisories are defined as follows:
- WARNING** Indicates a potentially hazardous situation which, if not avoided, could result in death or serious injury.
 - CAUTION** Indicates a potentially hazardous situation which, if not avoided, could result in minor or moderate injury. It could also be used to alert against unsafe equipment or property-damage only accidents.
 - NOTICE** Indicates a situation that could result in equipment or property-damage only accidents.

Important Environmental Concerns
Scientific research has shown that certain man-made chemicals can affect the earth's naturally occurring stratospheric ozone layer when released to the atmosphere. In particular, several of the identified chemicals that may affect the ozone layer are refrigerants that contain Chlorine, Fluorine and Carbon (CFCs) and those containing Hydrogen, Chlorine, Fluorine and Carbon (HCFCs). Not all refrigerants containing these compounds have the same potential impact to the environment. Trane advocates the responsible handling of all refrigerants-including industry replacements for CFCs such as HCFCs and HFCs.

Important Responsible Refrigerant Practices
Trane believes that responsible refrigerant practices are important to the environment, our customers, and the air conditioning industry. All technicians who handle refrigerants must be certified according to local rules. For the USA, the Federal Clean Air Act (Section 608) sets forth the requirements for handling, reclaiming, recovering and recycling of certain refrigerants and the equipment that is used in these service procedures. In addition, some states or municipalities may have additional requirements that must also be adhered to for responsible management of refrigerants. Know the applicable laws and follow them.

2

WARNING
Proper Field Wiring and Grounding Required!
Failure to follow code could result in death or serious injury. All field wiring MUST be performed by qualified personnel. Improperly installed and grounded field wiring poses FIRE and ELECTROCUTION hazards. To avoid these hazards, you MUST follow requirements for field wiring installation and grounding as described in NEC and your local/state electrical codes.

WARNING
Personal Protective Equipment Required!
Installing/servicing this unit could result in exposure to electrical, mechanical and chemical hazards. Before installing/servicing this unit, technicians MUST put on all Personal Protective Equipment (PPE) recommended for the work being undertaken. ALWAYS refer to appropriate MSDS sheets and OSHA guidelines for proper PPE. When working with or around hazardous chemicals, ALWAYS refer to the appropriate MSDS sheets and OSHA guidelines for information on allowable personal exposure levels, proper respiratory protection and handling recommendations. If there is a risk of arc or flash, technicians MUST put on all necessary Personal Protective Equipment (PPE) in accordance with NFPA70E for arc/flash protection PRIOR to servicing the unit. Failure to follow recommendations could result in death or serious injury.

WARNING
Follow EHS Policies!
Failure to follow instructions below could result in death or serious injury.
• All Ingersoll Rand personnel must follow Ingersoll Rand Environmental, Health and Safety (EHS) policies when performing work such as hot work, electrical, fall protection, lockout/tagout, refrigerant handling, etc. All policies can be found on the BOS site. Where local regulations are more stringent than these policies, those regulations supersede these policies.
• Non-Ingersoll Rand personnel should always follow local regulations.

3 General Information

Inspection
1. Verify all components are present.
2. Check carefully for any shipping damage. If any damage is found it must be reported immediately and a claim made against the transportation company.

- Parts List**
- 1 Aux Switch - SWT04018
 - 1 Actuator - ACT00672
 - 2 Screw - SCR02577(8-18 X 3/4 Pan Head Self-Drilling Screw)
 - 1 Spacer - SPC00211(0.34 ID X 0.44 OD X 0.25)
 - 1 Installation Instructions

Installation Procedure (Field Installed)

NOTICE
Equipment Damage!
Electrostatic discharge can short equipment circuitry. Ensure that you are properly grounded before handling the actuator.

- Refer to Figures 2 through 4 for the following steps.
1. Turn off power to the entire IntelliPak unit.
 2. Disconnect all wires attached to both the Honeywell actuator and aux switch.
 3. Remove Honeywell aux switch from actuator.
 4. Remove the anti-rotation screw and the spacer at the top of the actuator. Keep the spacer for use with the Trane actuator (4).
 5. Remove the actuator by loosening the set screws from the damper shaft.
 6. Turn the damper shaft arm (14) until it is at its lowest position, which should be approximately at 5 o'clock position.
 7. Orient actuator vertically upside down (power leads should be on top) and place the actuator (4) on the damper shaft (13).

4

8. Slide the curved 't' portion of the universal mounting bracket (6) into the center recess on top of the actuator (4), install spacers (7) under universal mounting bracket's mounting holes and secure it to the damper (12) with screws (5).
9. Press the override button (2) and rotate the universal clamp clockwise until mechanical stop is reached. Torque the two 10mm universal clamp nuts to 5 ft-lbs. Do not over torque. Press override button (2) and verify the movement is smooth with no binding. see Figure 6, p. 2.
10. Set the direction dial (3) to "0".
11. Place aux switch (10) onto the front of the actuator (4), see Figure 7, p. 2. Use the LM guiding grooves on the sides of the actuator, closest to the override button (2). The two black prongs on the back side of the aux switch go into the two holes on the universal clamp (1). The aux switch should snap into place.
12. Fully open air damper by pressing override button (2) and rotating damper shaft arm (14) counter-clockwise until it stops.
13. Check for continuity between the S1 (PUR) and S3 (WHT) aux switch (10) wires with the air damper fully open. If it reads open, then rotate aux switch dial (9) until continuity is achieved.

Note: Arrow should be pointing toward S1/S3 normally-closed indicator. (See figure below.)

Figure 1. Indicator - S1/S3 normally-closed

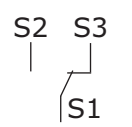

5

14. Actuator Wiring
 - a. Cut off the white Belimo connector and strip the leads.
 - b. Use field provided wire connectors to make the following wire changes:
 - i. BLK (1) - Common to 587D and 589A
 - ii. RED (2) - 24VAC to 588A
 - iii. WHT (3) - 0-10VDC Input to 590A
15. Aux Switch Wiring
 - a. Use field provided wire connectors to make the following wire changes:
 - i. PUR (S1) to 369C
 - ii. RED (S2) - Not Used
 - iii. WHT (S3) to 368B
16. Apply power to the IntelliPak 1 unit.
17. Enter Service Mode and verify proper operation per Engineering Bulletin SZ-SB-55.

6

Figure 2. Trane actuator and parts

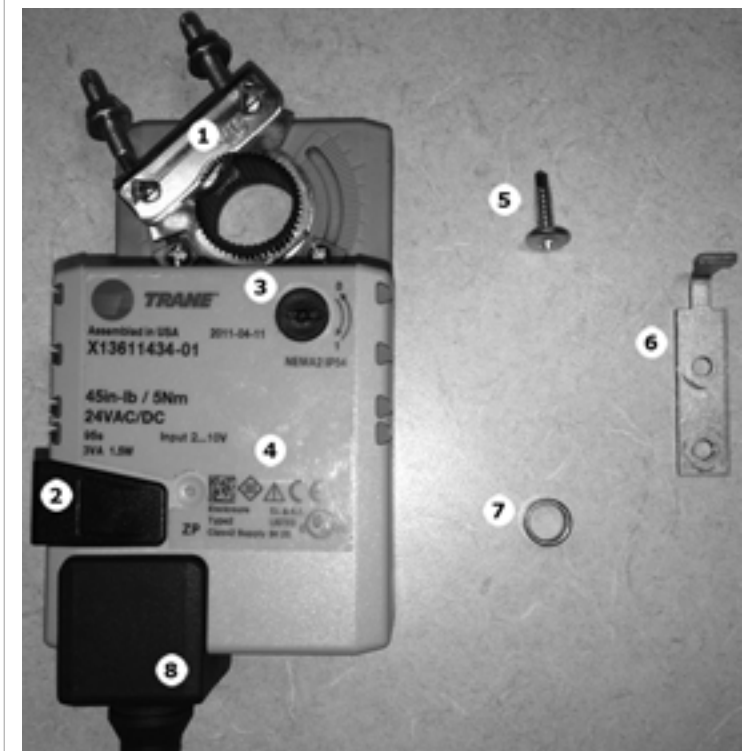

7

Figure 3. Auxiliary switch and position indicator



8

Figure 4. Actuator damper shaft

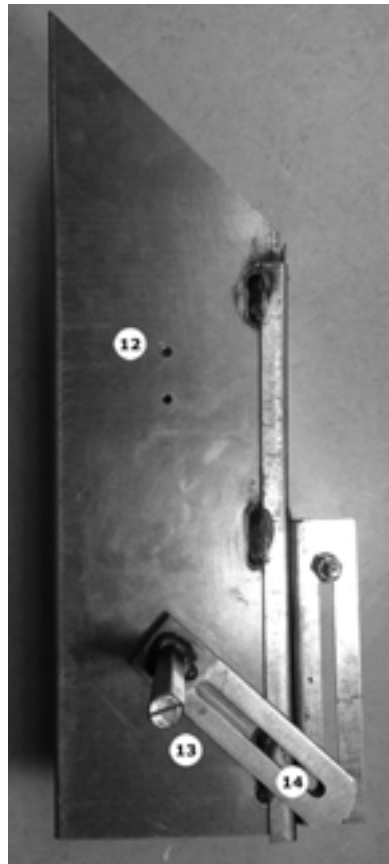

9

Figure 5. Universal mounting bracket

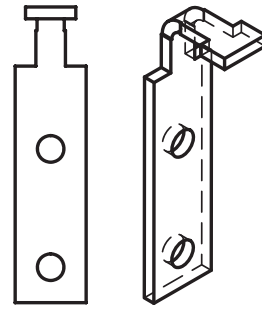

10

Figure 6. Actuator clamp position



11

Figure 7. Auxiliary switch and position indicator

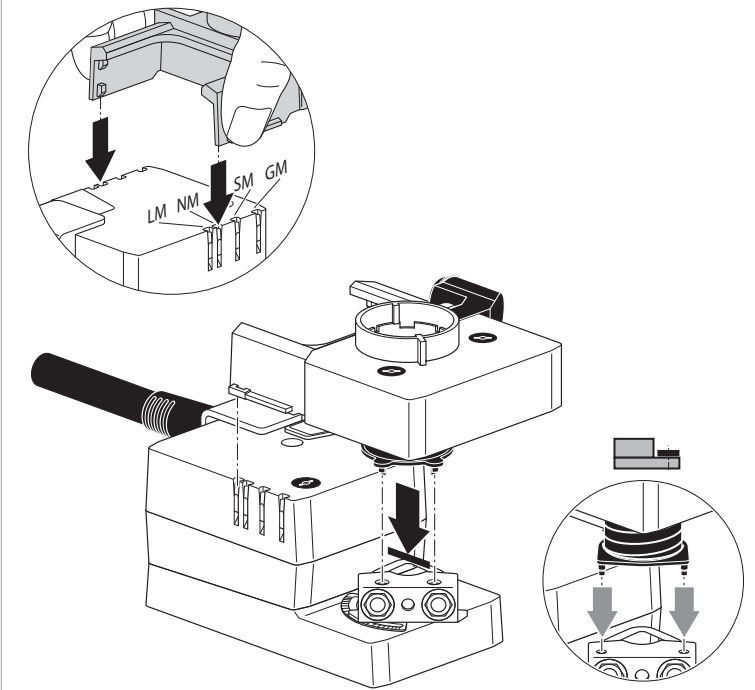

12

Figure 8. Auxiliary switch setting (full open)



Ingersoll Rand (NYSE:IR) advances the quality of life by creating comfortable, sustainable and efficient environments. Our people and our family of brands—including Club Car®, Ingersoll Rand®, Thermo King® and Trane®—work together to enhance the quality and comfort of air in homes and buildings; transport and protect food and perishables; and increase industrial productivity and efficiency. We are a global business committed to a world of sustainable progress and enduring results.



ingersollrand.com

Ingersoll Rand has a policy of continuous product and product data improvement and reserves the right to change design and specifications without notice. We are committed to using environmentally conscious print practices.

RT-SVN026B-EN 28 Mar 2018
Supersedes RT-SVN026A-EN (Jan 2017)

©2018 Ingersoll Rand