



TRANE™

General Service Bulletin

RTHA-SB-5A

Library	Service Literature
Product Section	Refrigeration
Product	Rotary Liquid Chillers - Water-Cooled
Model	RTHA
Literature Type	General Service Bulletin
Sequence	5A
Date	February 7, 1991
File No.	SV-RF-RLC-RTHA-SB-5A-291
Supersedes	RTHA-SB-5-5/5/90

Literature Change History:

RTHA-SB-5 (5/90) -- Original Service Bulletin

RTHA-SB-5A (2/91) -- Bulletin revised to update electrical schematics and provide additional information on UCM Dip switch settings.

Subject: Control Operation, Setup and Troubleshooting for RTHA (Series R) Liquid Chiller Control Panel.

Introduction:

The purpose of this Service Bulletin is to provide control operation and general troubleshooting information for Trane CenTraVac model RTHA microprocessor control panels.

Discussion:

This bulletin is intended to serve as a supplement to the operation and maintenance literature for RTHA units. Subjects covered in this bulletin are intended to provide more comprehensive information for RTHA units.

Caution: Be sure to refer to wiring diagrams that apply specifically to the design sequence of the unit being serviced.

Note:

The Trane Company urges all HVAC servicers working on Trane equipment, or any manufacturer's products, make every effort to eliminate, if possible, or vigorously reduce the emission of CFC, HCFC and HFC refrigerants to the atmosphere resulting from installation, operation, routine maintenance, or major service on this equipment. Always act in a responsible manner to conserve refrigerants for continued use even when acceptable alternatives are available.

Since The Trane Company has a policy of continuous product improvement, it reserves the right to change specifications and design without notice. The installation and servicing of the equipment referred to in this booklet should be done by qualified, experienced technicians.

Table of Contents

3	Control Panel Codes and Menu Charts	27	Temperature Sensor Check-out Procedure
3	UCP Overview	35	Troubleshooting with Control Panel Diagnostics
6	RTHA Compressor Electrical Phasing	35	b A3 Evaporator Refrigerant Temperature Range
7	-Correcting Improper Electrical Phase Sequence	35	b A4, A7, A8 Motor Temperature Sensors
7	Phase Monitor Operation for Remote and Unit Mounted Starts	36	b Ab Leaving (Evaporator) Water Temperature Sensor
7	2U1 United Mounted Starter Phase Reversal Monitor	36	b Ad Evaporator Refrigerant Temperature Sensor
7	4U1 Remote Mounted Starter Phase Reversal Monitor	36	b AE Ambient Temperature Sensor (Optional)
7	RTHA Electrical Diagrams	36	b d9 Extended Power Loss
16	Factory Setup for UCM Dip Switches	36	b dc Condenser Water Flow Overdue
16	Switch Block S11: Unit Address	37	b E2 Momentary Power Loss
16	Switch Block S9: Unit Identification; Temperature Range; Unit of Measure	37	b E3 Phase Imbalance (Optional)
16	-Hot Gas Bypass	37	b E4 Phase Loss
16	-Pressure	39	b E5 Phase Reversal
17	-Temperature Range	39	b E7 High Motor Temperature
17	-Unit of Measure	39	b F2 Proving Oil Flow
17	Switch Block S3: Frequency; Phase Imbalance	39	b E8 Oil Flow Switch Closed
17	-Frequency Adjustment (50/60 Hz)	40	b E9 Stop Relay
17	-Unit of Measure	40	b EC Running Overload
17	Switch Block S1: Rated Load Amps (RLA) Setpoint	40	b Ed Chilled Water Flow
21	Input Connections (and Terminal Designations)	41	b FO Transition
21	Terminal Strip 1TB6: Bidirectional Communications Link	42	b F1 Running External Interlock
21	Terminal Strip 1TB3	42	Power Supply Checkout Procedure
21	-Leaving Evaporator Water Temperature Sensor (1TB3-1, -2)	42	Overview
22	-Entering Evaporator Water Temperature Sensor (1TB3-3, -4)	42	-Power Supply Output Module 1U2 Checkout (Figure 8)
22	-Spare Temperature Sensors (1TB3-5, -6; 1TB3-7, -8)	45	-Power Transformer (1T1) Checkout (Figure 8)
22	-Condenser Refrigerant Pressure Transducer (1TB3-9, -10, -11)	47	Compressor Transition Relay 1U2K5 and Current Transformer Checkout Procedures
22	-Evaporator Refrigerant Temperature Sensor (1TB3-12, -13)	48	Faulty current-sensing inputs (1TB4-7 thru -12)
23	-Ambient Temperature Sensor (1TB3-14, -15)	48	Defective micro module (1U3)
23	-External Inhibit (1TB3-16, -17)	48	Defective power supply output module (1U2)
24	-Proof of Chilled Water Flow (1TB3-20, 21)	48	Faulty starter component(s) or wiring
24	-Proof of Condenser Water Flow (1TB3-22, 23)	48	Faulty "proof-of-transition" circuit
24	-Low Pressure Cutout (1TB3-24, -25)	49	1U2K5 Checkout Procedure
25	Terminal Strip 1TB4	49	Current Transformer Check-out
25	-Proving Oil Flow (1TB4-1, -2)	52	Checkout Procedure for Slide Valve Operation
25	-Running External Interlock (1TB4-3, -4)	52	Slide Valve Control Switch
25	-"Transition Complete" Contacts (1TB4-5, -6)	52	Pressure Gauge
25	-3-Phase Current-Sensing Input (1TB4-7 thru -12)	52	Load
26	-Discharge Temp Sensor (1TB4-19, -20)	52	Hold
26	-Motor Winding Temperature Sensors (1TB4-15 thru -18)	52	Unload
		52	Auto
		52	Condenser Water Pump Relay Checkout
		52	Relay Operation
		52	Relay Troubleshooting

Control Panel Codes And Menu Charts

UCP Overview

The microprocessor-based, UCP control panel visually indicates chiller operating and diagnostic codes at the display window; see Figure 1. If the UCM (i.e., unit control module) detects a diagnostic condition, it alternately flashes the 3-digit unit operating mode (i.e., code prefix A) at the time the unit shutdown and the 3-digit diagnostic code (i.e., code prefix B) on the display.

Figure 1
UCP Micro Module 1U3

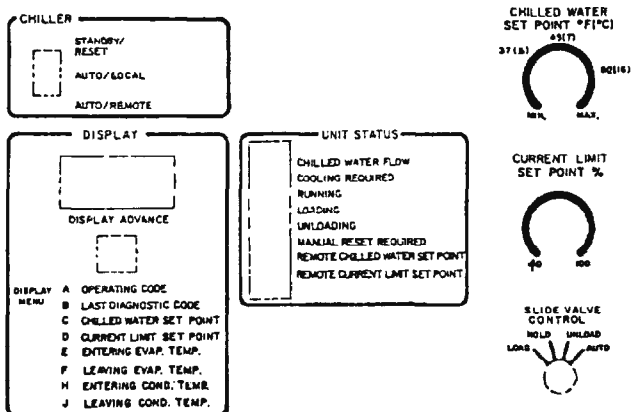

Note: A latching diagnostic condition (i.e., one requiring manual reset) detected by the unit control panel cannot be cleared from a higher level device (i.e., an SCP, Tracer or generic BAS). A manual reset must be performed at the UCP control panel.

Complete listings of the codes used to identify RTHA operating modes and diagnostic conditions, along with the display menus, are provided in Tables 1, 2 and 3, respectively.

**Table 1
Codes for Unit
Operating Modes**

3-Character Code	Description of Operating Mode
Blank	Power Off
A 0	Standby/Reset
A 1	Auto (Local or Remote)
A 70	Restart Inhibit
A 71	Establish Condenser Water Flow
A 72	Start
A 74	Run: Normal
A 75	Run: Current Limit (1)
A 76	Run: Condenser Limit (2)
A 77	Run: Evaporator Limit (3)
A 7A	Run: Hot Gas Bypass
A 100	External Inhibit
A 7C	Stop: Minimum Off Time
A 88	Reset

Notes:

- As the current limit setpoint is approached, the UCM restricts further advancing of the compressor slide valve.
- As the condenser limit setpoint is reached, the UCM restricts additional compressor loading to avoid shutdown on high condenser pressure (b F5), and initiates a "head relief request" (i.e., optional relay).
- The UCM restricts further retraction of the compressor slide valve to avoid a unit shutdown on low evaporator refrigerant temperature (b Fb).

**Table 2
Unit Diagnostic Codes**

3-Character Code	Diagnostic Description	System Reset
b A3	Evaporator Refrigerant Temp. Range	Manual
b A4	Sensor Failure - Motor Temp. Sensor #1	Manual
b A7	Sensor Failure - Motor Temp. Sensor #2	Manual
b A8	Sensor Failure - Motor Temp. Sensor #3	Manual
b Ab	Sensor Failure - Evap. Leaving Water Temperature Sensor	Manual
b Ac	Sensor Failure - Condenser Refrigerant Pressure Sensor	Manual
b Ad	Sensor Failure - Evaporator Refrigerant Temperature Sensor	Manual
b Ae	Sensor Failure - Ambient Temperature Sensor (Opt.)	Manual
b 80	Sensor Failure - Discharge Gas. Temp. Sensor	Manual
b b5	Low Evaporator Refrigerant Pressure	Manual
b d9	Extended Power Loss	Automatic
b dc	Condenser Water Flow Overdue	Manual
b E2	Momentary Power-Loss	Automatic
b E3	Phase Imbalance	Manual
b E4	Phase Loss	Manual
b E5	Phase Reversal	Manual
b E7	High Motor Temperature	Manual
b E8	Oil Flow Switch Closed	Manual
b E9	Stop Relay	Manual
b Ec	Running Overload	Manual
b Ed	Chilled Water Flow Failure	Automatic
b F0	Starter Transition Failure	Manual
b F1	Running External Interlock (Opt.)	Manual
b F2	Low Oil Flow	Manual
b F5	High Condenser Refrigerant Pressure	Manual
b F7	Condenser Water Flow Failure	Automatic
b F8	Improper Unit Identification	Manual
b Fb	Low Evaporator Refrigerant Temperature	Manual
b FF	Unit Control Module	Manual
b 84	High Discharge Gas Temperature	Manual

Notes:

- Check the "Manual Reset Required" status indicator light to determine if manual reset is necessary.
- It is not possible to clear a latching diagnostic condition (i.e., one requiring manual system reset) at the unit from a higher level device (e.g., a system control panel, Tracer, or generic BAS).

**Table 3
Display Menus**

Operator's Menu		Serviceman's Menu (1, 3) (Slide Valve Control Switch at "Hold")	
Code Prefix	Parameter Description and Display Range	Code Prefix	Parameter Description Diagnostic Code and Display Range
A	Operating Mode (see Table 3)	A	Operating Mode (see Table 3)
b	Last Diagnostic (see Table 4)	b	Last Diagnostic (see Table 4)
C	Chilled Water Setpoint Standard-range: 37 thru 60 F Extended-range: 20 thru 70 F	F	Panel Chilled Water Setpoint Range: ---, 20 thru 70 F ---
d	Active Current Limit Setpoint Range: 40 thru 100% RLA	—	Panel Current Limit Setpoint Range: ---, 40 thru 100% RLA ---
E	Entering Evaporator Water Temperature (Opt.) Range: ---, 12 thru 91 F ---	—	Evaporator Refrigerant Temp. (2) Diag. Code: <u>b Ad</u> Range: -4 thru 42 F ---
F	Leaving Evap Water Temp. Diag. Code: <u>b Ab</u> Range: 12 F thru 91 F	L	Control Response Setpoint Range: 1 thru 237
H	Entering Condenser Water Temperature (Opt.) Range: ---, 28 thru 142 F	□	Start Differential Setpoint Range: 2 thru 10F
J	Leaving Condenser Water Temperature (Opt.) Range: ---, 28 thru 142 F, --	F	Condenser Limit Setpoint Range: 80 thru 120% HPC
(Blank)		□	Evaporator Refrigerant "Trip" Setpoint (Diag. Code: <u>b A3</u>) Standard-range = 29 thru 34 F Extended-range = 0 thru 34 F

Notes:

1. To switch from "operator's menu" to the "serviceman's menu" on the UCM display, turn the Slide Valve Control Switch to "Hold". To switch back to "operator's menu", turn the switch to any position other than "Hold".
2. For further information on any of the items listed in the "serviceman's menu", contact a qualified service organization.

RTHA Compressor Electrical Phasing

Note: It is essential that proper rotation of the RTHA compressor be established before the machine is started. Proper motor rotation requires confirmation of the electrical phase sequence of the power supply. The motor is internally connected for clockwise rotation with the inlet power supply phased A, B, C.

To confirm the correct phase sequence (ABC), use a Model 45 Associated Research Phase Indicator or equivalent. See Figure 2.

Basically, voltages generated in each phase of a polyphase alternator or circuit are called phase voltages. In a three-phase circuit, three sine wave voltages are generated, differing in phase by 120 electrical degrees. The order in which the three voltages of a three-phase system succeed one another is called phase sequence or phase rotation. This is determined by the direction of rotation of the alternator. When rotation is clockwise, phase sequence is usually called "ABC", when counterclockwise, "CBA".

This direction may be reversed outside the alternator by interchanging any two of the line wires. It is this possible interchange of wiring that makes a phase sequence indicator necessary if the operator is to quickly determine the phase rotation of the motor.

Figure 2
Associated Research Model 45
Phase Sequence Indicator

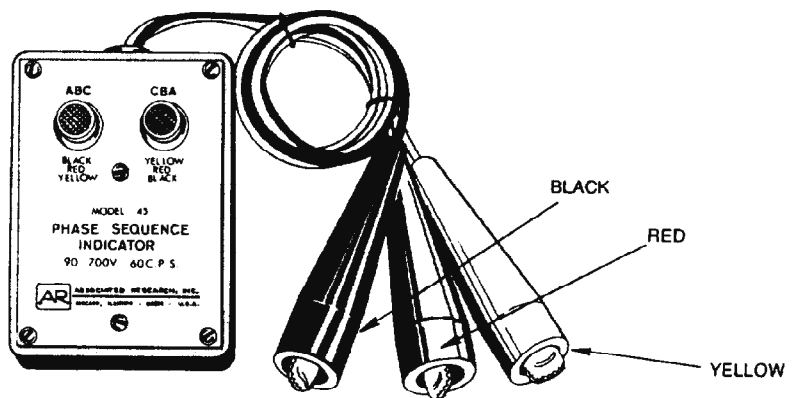

Note: It is essential to confirm that proper phase rotation is established, Phase A to L1, Phase B to L2, and Phase C to L3. It is extremely important that phase rotation be checked with a phase sequence indicator before start-up of chiller due to the possibility of catastrophic damage to compressor occurring if rotation is reversed.

Do not rely on the phase sequence relay in the starter panel (remote or unit mounted) or motor terminal box to indicate phase rotation on initial start-up or if building power has been modified. If rotation is incorrect, change the phasing at the incoming power to the starter. Do not attempt to change rotation at the motor terminals.

Correcting Improper Electrical Phase Sequence

Proper compressor motor electrical phasing can be quickly determined and corrected before starting the unit. Use a quality instrument such as an Associated Research Model 45 Phase Sequence Indicator and follow this procedure:

1. Turn chiller switch on the UCM to STOP/RESET position.
2. Open the electrical disconnect or circuit protection switch that provides line power to the line power terminal block (2CB1 or 2TB2) in the control panel or to the unit-mounted disconnect.
3. Connect the phase sequence indicator leads to 2CB1 or 2TB2 (or disconnect) as follows:

Phase Seq. Lead	2CB1 or 2TB2 Terminal
Black (Phase A)	1
Red (Phase B)	2
Yellow (Phase C)	3

4. Turn power on by closing the unit supply power fused disconnect switch.
5. Read the phase sequence displayed on the indicator. The "ABC" LED on the face of the phase indicator will glow if phase sequence is ABC.

WARNING! To prevent injury or death due to electrocution, take extreme care when performing service procedures with electrical power energized.

6. If the "CBA" indicator glows instead, open the unit main power disconnect and switch two line leads on 2CB1 or 2TB2. Re-close the main power disconnect and re-check phasing.
7. Reopen the unit disconnect and disconnect the phase indicator.

Phase Monitor Operation for Remote and Unit Mounted Starters

2U1 Unit Mounted Starter Phase Reversal Monitor will look at incoming power to make sure that a clockwise rotation is confirmed. If phasing is correct Pilot Relay (2K5) will pull in and begin the start procedure. In the event of a counterclockwise rotation, Phase Reversal Monitor (2U1) will not close its contact which will not allow Pilot Relay (2K5) to energize, therefore the start procedure will not occur. In some cases, when the C.T.'s do not sense current draw but a start is initiated and the Phase Monitor locks out (2K5), a phase-loss diagnostic may occur.

4U1 Remote Mounted Starter Phase Reversal Monitor monitors phasing at motor terminals T1, T2, and T3. When the starter contactor pulls in and phasing is incorrect the contactor will instantaneously drop out. When 4U1 detects a counterclockwise rotation 4U1 contacts will close, energizing 4K18. One contact of the Phase Reversal Lockout Relay (4K18) will open and the other set of contacts will close causing the Phase Reversal Indicator to light and lock in 4K18. When the normally closed contact of 4K18 opens, power is no longer allowed to 1U2 to continue the start procedure.

RTHA Electrical Diagrams

Refer to Figures 3 through 6 for typical RTHA wiring schematics and connection diagrams.

Figure 3
System Schematic Diagram for RTHA Units with Unit Mounted
"Wye-Delta" Starter (Page 1)

RTHA-SB-5

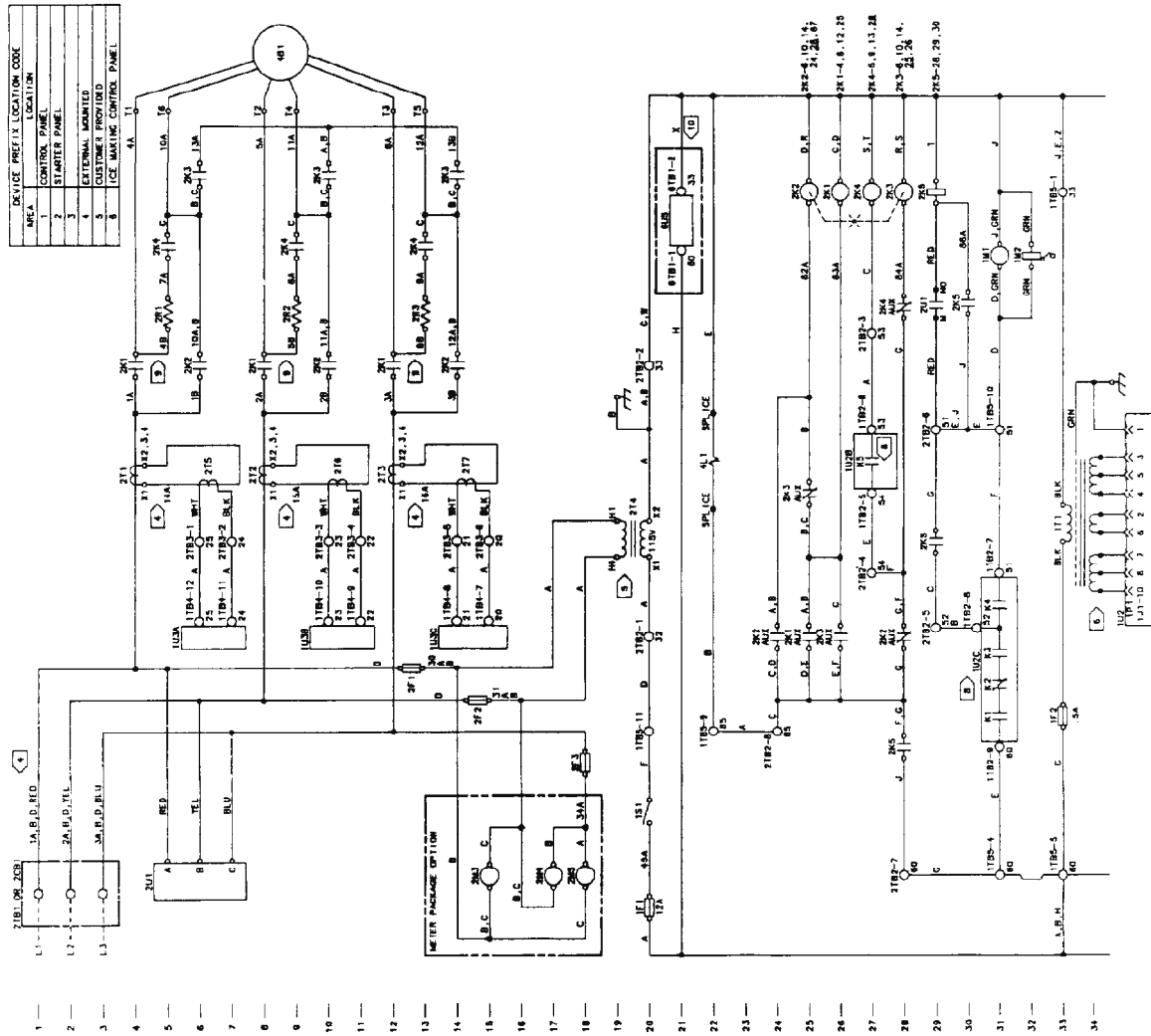

Continued on next Page

Continued from previous page

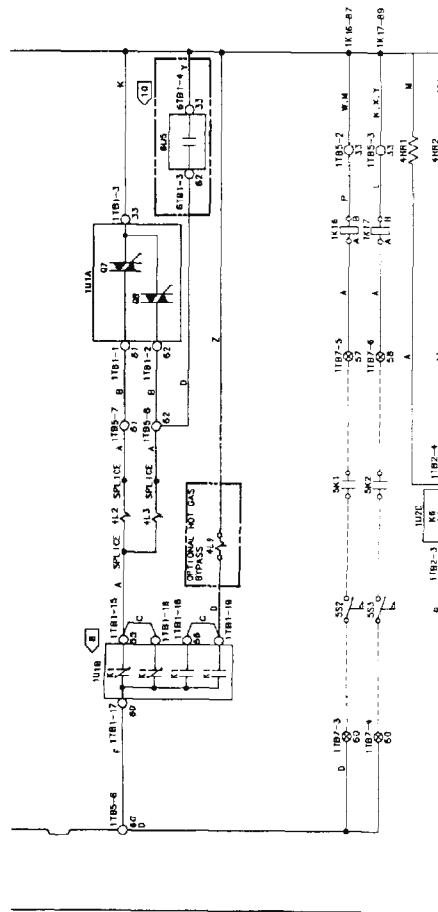

⚠ WARNING
 HAZARDOUS VOLTAGE!
 DISCONNECT ALL ELECTRIC POWER
 SUPPLY BEFORE SERVICING.
 FAILURE TO DISCONNECT POWER SUPPLY
 BEFORE SERVICING CAN CAUSE SEVERE
 PERSONAL INJURY OR DEATH DUE TO
 ELECTRICAL SHOCK.

⚠ AVERTISSEMENT
 VOLTAGE HAZARDEUX!
 DECONNECTEZ TOUTS LES INTERRUPTEURS
 AVANT D'EFFECTUER L'ENTRETIEN.
 FAUTE DE DECONNECTER LA SOURCE
 ELECTRIQUE AVANT D'EFFECTUER
 L'ENTRETIEN PEUT CAUSER DES BLESSURES
 SEVERES OU LA MORT PAR ELECTROCUTION.

⚠ IMPORTANT
 USE COPPER CONDUCTORS ONLY
 FOR ALL WIRING. COPPER IS THE ONLY
 UNIT TERMINALS ARE NOT DESIGNED
 TO ACCEPT ANY OTHER WIRING.

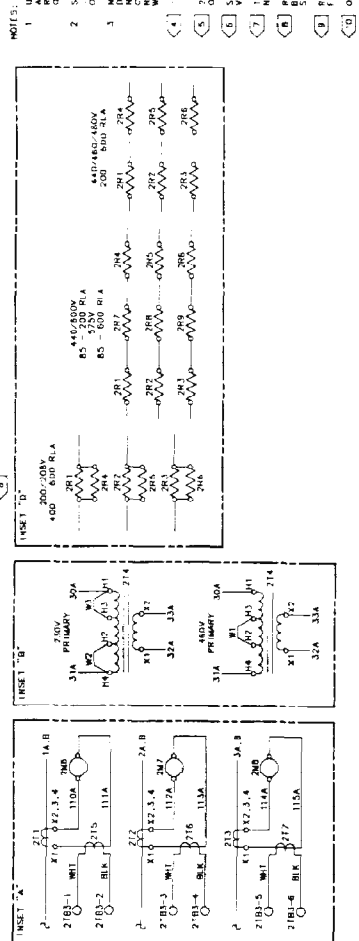

- NOTES:
1. UNLESS OTHERWISE NOTED, ALL SWITCHES AND RELAYS ARE TO BE OPERATED WITH ALL LINES TURNED OFF AND AFTER A NORMAL SHUTDOWN HAS OCCURRED.
 2. INDICATED WIRING PHANTOM LINES INDICATE OPTIONAL FEATURES.
 3. NUMBERS ALONG THE RIGHT SIDE OF THE SCHEMATIC NUMBER AN UNDERLINED NUMBER INDICATES A TERMINAL NUMBER PRINTING UPWARD INDICATES A TAPPED CONTACT WHICH BEGINS TAPPING WHEN ENERGIZED.
 4. METER PACKAGE OPTION IS REQUIRED SEE PAGE 14.
 5. THE METER PRIMARY SHOWN SEE INSET 'B' FOR OTHER VOLTAGES.
 6. SEE SERVICE MANUAL FOR INDIVIDUAL SECONDARY VOLTAGES.
 7. THREE PHASE POWER SUPPLY VOLTAGE SEE INSET 'B' FOR NAME PLATE.
 8. RELAY COILS NOT SHOWN CONTACTS ARE UNCONTROLLED SEQUENCE OF OPERATION LINES 102-115 PAGE 2.
 9. RESISTOR SHOWN FOR 200/200V AND 200-100-0-200V FOR OTHER VOLTAGES AND RELAY SET INSET 'D'.
 10. OPTIONAL ICE MARKING CONTROL INPUT.

X39530056A

Figure 6
System Schematic for RTHA units with Remote-Mounted
"Wye-Delta" Starter (Page 1)

RTHA-SB-5

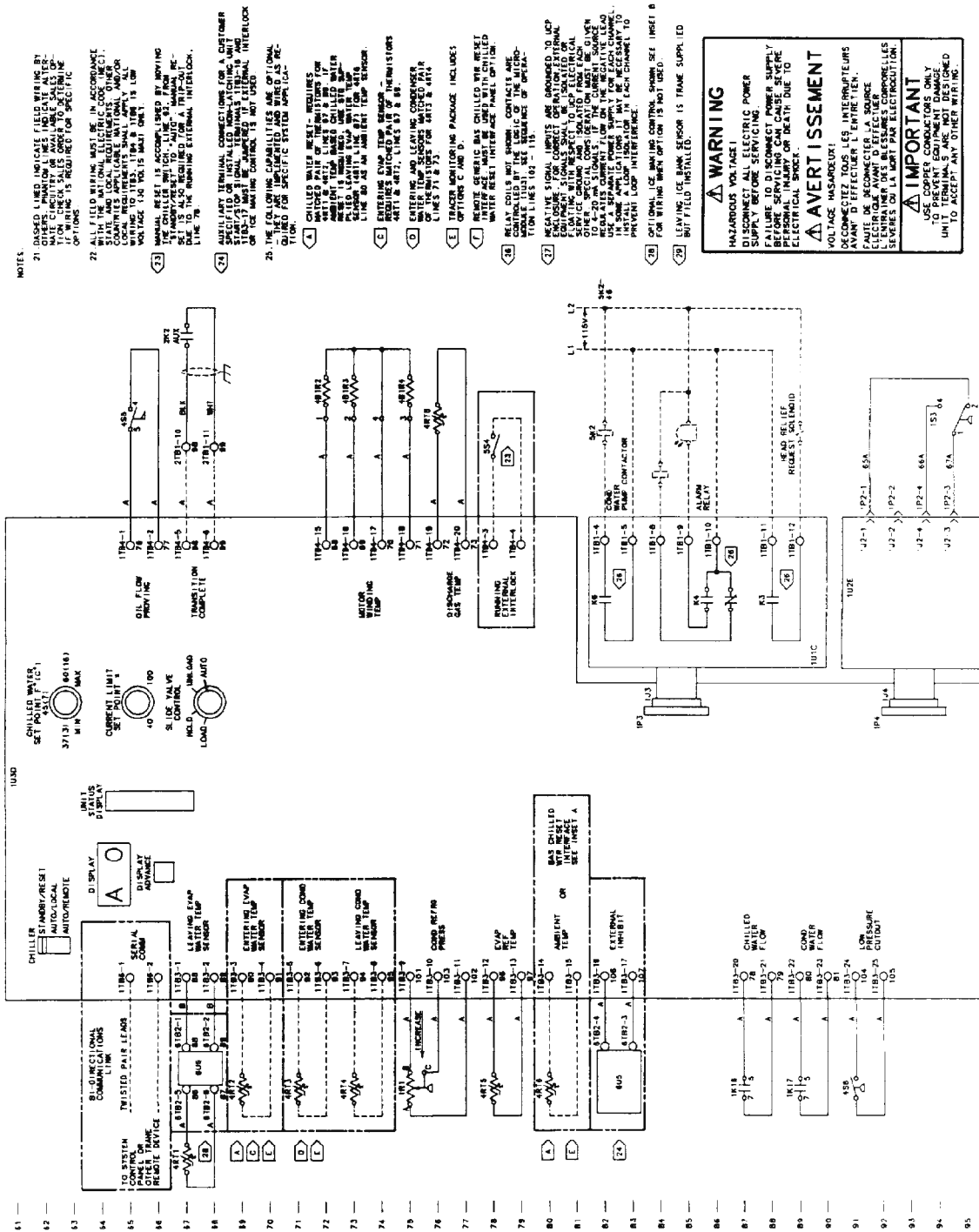

Continued on next page

Continued from previous page

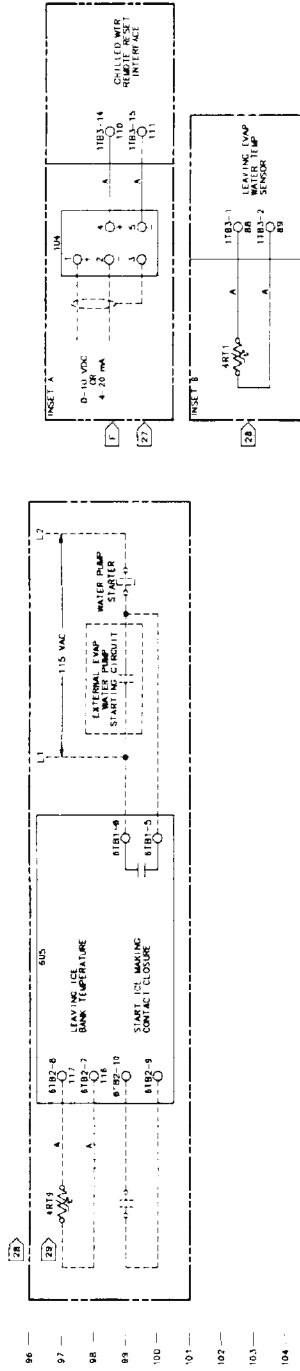

SEQUENCE OF OPERATION

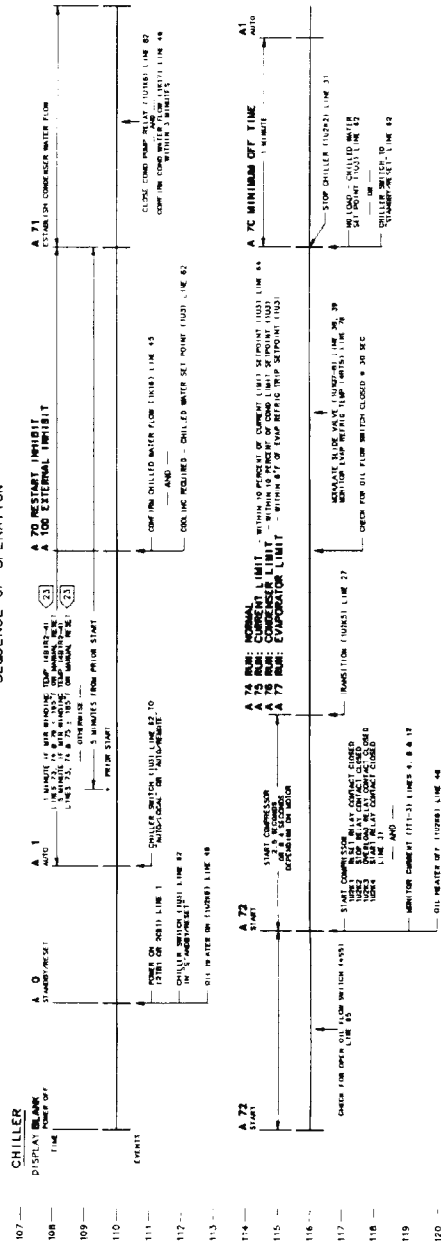

X39530062A

Factory Setup for UCM DIP Switches

Controls included in this section are factory-set, and do not require adjustment at initial start-up or during operation of the unit. Use the information provided here only to check the switch setting at initial start-up, or when a new micro module (1U3) is installed.

To access the UCM control components described below, open the unit control panel door and remove the access cover strip located at the top of the micro module. All of the necessary factory inputs are accomplished via 4 DIP switch blocks.

Switch Block S11: Unit Address

This DIP switch block must be set when the unit is used in conjunction with an SCP system control panel. The switches are adjusted to "tag" the chiller with a binary address of either "1", "2", or "3" as indicated below:

Dip Switch Settings					Corresponding Binary Unit Address
1	2	3	4	5	
On	On	On	On	Off	= 1
On	On	On	Off	On	= 2
On	On	On	Off	Off	= 3

Note: Remember that all units communicating with an SCP must have separate, unique addresses. If 2 or more units connected to an SCP share the same address, communications are automatically terminated.

Switch Block S9: Unit Identification; Temperature Range; Unit of Measure

Position	Description	On	Off
S9-1	SCP I.D.	RTHA	----
S9-2	Hot Gas Bypass	Not Installed	Installed
S9-3	Pressure	Standard	Heat Recovery
S9-4	Temp Range	Standard	Extended
S9-5	Unit of Measure	English	SI

System Control Panel (SCP) Identification

The position of DIP Switch No. 1 on switch block S9 must be ON when the chiller UCM is connected to a SCP (System Control Panel). This is applicable with UCM's that have a UCM I.D. No. of X13650329 (stamped on the right side of the UCM). If UCM has an I.D. No. of X13650401, this switch is not used.

Hot Gas Bypass

The position of DIP switch No. 2 on switch block S9 determines if the unit will operate in the Hot Gas Bypass mode.

Pressure

The position of DIP switch No. 3 on switch block S9 determines the limit of condenser pressure. Standard pressure selection will cause the 100% condenser limit to be 270 psig. Heat Recovery units will operate with a 100% condenser limit of 360 psig.

Note: When description is either "not used" or "not installed", DIP switch can be either off or on.

Temperature Range

The position of DIP switch No. 4 on switch block S9 determines the range of adjustability for the chilled water and evaporator refrigerant "trip" point potentiometers. The standard temperature range for the chilled water setpoint is 37 F to 60 F, and that of the evaporator refrigerant "trip" point is 29 F to 34 F. When the extended temperature range function is enabled, however, these control ranges are expanded to include 20 F to 70 F for the chilled water setpoint, and 0 F to 34 F for the evaporator refrigerant "trip" point.

Caution: DIP switch No. 4 should be On unless the unit is designed to operate beyond the standard temperature range. Improper chiller operation at "extended" temperature range conditions may result in catastrophic equipment failure.

Unit of Measure

DIP Switch No. 5 on switch block S9 determines whether the temperatures shown on the micro module's display are indicated in degrees F or degrees C. DIP switch No. 5 should remain in the "On" position for all domestic chiller applications.

Switch Block S3: Frequency; Phase Imbalance

Position	Description	On	Off
S3-1	Transition Time	2.8 Seconds	8.4 Seconds
S3-2	Transition Time	2.8 Seconds	8.4 Seconds
S3-3	Transition Time	2.8 Seconds	8.4 Seconds
S3-4	Transition Time	2.8 Seconds	8.4 Seconds
S3-5	Transition Time	2.8 Seconds	8.4 Seconds
S3-4	Transition Time	2.8 Seconds	8.4 Seconds
S3-5	Transition Time	2.8 Seconds	8.4 Seconds
S3-6	Frequency	50 Hertz	60 Hertz
S3-7	Phase Imbalance	Overridden	Operational

Transition Time

This is the time allotted from initial motor starting to the time the UCM initiates starter transition to place the motor across line (i.e., auto-transformer and Wye Delta starters). Transition time on an RTHA is strictly a function of time.

Dip Switches Nos. 1 thru 5 on switch block S3:

On UCM's with ID # of X13650329 (Right hand side of UCM) these switches are not used. The transition time of these UCM's is 2.8 seconds and is not adjustable.

On UCM's with ID # of X13650401 (Right hand side of UCM) October '90 and later production) these switches will determine transition time.

All 5 switches ON = 2.8 seconds for RTHA 130-215.

All 5 switches OFF = 8.4 seconds for RTHA 255-450.

All 5 switches must be set alike (i.e., all 5 ON or all 5 OFF).

Frequency Adjustment (50/60 Hz)

DIP switch No. 6 on switch block S3 allows the UCM to accept either 50- or 60-hertz supply power, depending on its position. This DIP switch must be configured to match incoming power.

Phase Imbalance

DIP switch No. 7 of switch block S3 determines whether or not this motor protection function is operational. DIP switch No. 7 should remain in the "Off" position. However, if jobsite conditions cause nuisance "trips", this protection may be overridden temporarily until the problem is diagnosed and corrected.

Switch Block S1: Rated Load Amps (RLA) Setpoint

The RLA setpoint is factory set using DIP switches No. 1 through 8 of switch block S1, and is based on nameplate RLA, current transformer ratio selection, and other design constants. RLA "trip" point is based on current transformer (CT) selection, and adjustment resolution is 1% of RLA minimum. To determine the appropriate DIP switch setting combination, review the data provided in Tables 4 and 5. Use Steps 1 through 5 along with Table 4 to determine the appropriate RLA "factor" for your unit; then locate that "factor" in Table 5 to verify that the factory set S1 DIP switch arrangement is correct.

**Table 4
Unit RLA/Meter Scale
Conversion**

RLA Range	CT Ratio (1)	Primary Turns (2)	Meter Scale (3)
28.6 to 35.7	150 : 5	3	50
35.8 to 42.8	180 : 5	3	60
42.9 to 53.5	150 : 5	2	75
53.6 to 64.2	180 : 5	2	90
64.2 to 71.4	200 : 5	2	100
71.5 to 89.2	250 : 5	2	125
89.3 to 107.1	150 : 5	1	150
107.2 to 128.5	180 : 5	1	180
128.6 to 142.8	200 : 5	1	200
142.9 to 178.5	250 : 5	1	250
178.6 to 214.2	300 : 5	1	300
214.3 to 250.0	350 : 5	1	350
250.1 to 285.7	400 : 5	1	400
285.8 to 357.1	500 : 5	1	500
357.2 to 428.5	600 : 5	1	600
428.6 to 500.0	700 : 5	1	700
500.1 to 571.4	800 : 5	1	800
571.5 to 714.2	1000 : 5	1	1000
714.3 to 857.1	1200 : 5	1	1200
857.2 to 1071.4	1500 : 5	1	1500
1071.5 to 1285.7	1800 : 5	1	1800
1285.8 to 1500	2100 : 5	1	2100
1500.1 to 1785.7	2500 : 5	1	2500

Notes:

1. The CT (current transformer) ratio represents the size of the current transformers used with the specified RLA range.
2. Each "primary turns" (PRI) value indicates the number of times that the main power line passes through its current transformer.

Examples:

PRI = 1

PRI = 2

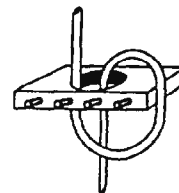
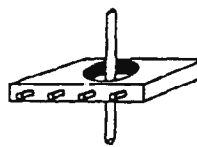

3. If ammeters are used with the CTs, their full-scale deflection will equal the "meter scale" values in this table.

Note: Meter Scale = $\frac{\text{CT Ratio (1)}}{\text{Primary Turns (2)}}$

Table 5
RLA Factor/S1 DIP Switch Settings
Conversion

RLA Factor	Switch Block S1 DIP Switches							
	1	2	3	4	5	6	7	8
0.799964	Off	Off	Off	Off	Off	Off	Off	Off
0.801220	Off	Off	Off	Off	Off	Off	Off	On
0.802480	Off	Off	Off	Off	Off	Off	On	On
0.803743	Off	Off	Off	Off	Off	On	Off	On
0.805011	Off	Off	Off	Off	Off	On	On	On
0.805022	Off	Off	Off	Off	On	Off	Off	Off
0.806294	Off	Off	Off	Off	On	Off	Off	On
0.807570	Off	Off	Off	Off	On	Off	On	On
0.808850	Off	Off	Off	Off	On	On	Off	On
0.810134	Off	Off	Off	Off	On	On	On	On
0.810180	Off	Off	Off	On	Off	Off	Off	Off
0.811468	Off	Off	Off	On	Off	Off	Off	On
0.812761	Off	Off	Off	On	Off	Off	On	On
0.814058	Off	Off	Off	On	Off	On	Off	On
0.815359	Off	Off	Off	On	Off	On	On	On
0.815370	Off	Off	Off	On	On	Off	Off	Off
0.816676	Off	Off	Off	On	On	Off	Off	On
0.817985	Off	Off	Off	On	On	Off	On	On
0.819299	Off	Off	Off	On	On	On	Off	On
0.820220	Off	Off	Off	On	Off	Off	Off	Off
0.820617	Off	Off	Off	On	On	On	On	On
0.821541	Off	Off	On	Off	Off	Off	Off	On
0.822867	Off	Off	On	Off	Off	Off	On	On
0.824197	Off	Off	On	Off	Off	On	Off	On
0.825531	Off	Off	On	Off	Off	On	On	On
0.825543	Off	Off	On	Off	On	Off	Off	Off
0.826881	Off	Off	On	Off	On	Off	Off	On
0.828224	Off	Off	On	Off	On	Off	On	On
0.829572	Off	Off	On	Off	On	On	Off	On
0.830924	Off	Off	On	Off	On	On	On	On
0.830972	Off	Off	On	On	Off	Off	Off	Off
0.832328	Off	Off	On	On	Off	Off	Off	On
0.833689	Off	Off	On	On	Off	Off	On	On
0.835055	Off	Off	On	On	Off	On	Off	On
0.836425	Off	Off	On	On	Off	On	On	On
0.836437	Off	Off	On	On	On	Off	Off	Off
0.837812	Off	Off	On	On	On	Off	Off	On
0.839192	Off	Off	On	On	On	Off	On	On
0.840576	Off	Off	On	On	On	On	Off	On
0.841964	Off	Off	On	On	On	On	On	On
0.842654	Off	On	Off	Off	Off	Off	Off	Off
0.844050	Off	On	Off	Off	Off	Off	On	On
0.845450	Off	On	Off	Off	Off	Off	On	On
0.846855	Off	On	Off	Off	Off	On	Off	On
0.848265	Off	On	Off	Off	Off	On	On	On
0.848278	Off	On	Off	Off	On	Off	Off	Off
0.849692	Off	On	Off	Off	On	Off	Off	On
0.851112	Off	On	Off	Off	On	Off	On	On
0.852536	Off	On	Off	Off	On	On	Off	On
0.853965	Off	On	Off	Off	On	On	On	On
0.854016	Off	On	Off	On	Off	Off	Off	Off
0.855450	Off	On	Off	On	Off	Off	Off	On
0.856889	Off	On	Off	On	Off	Off	On	On
0.858333	Off	On	Off	On	Off	On	Off	On
0.859782	Off	On	Off	On	Off	On	On	On
0.859794	Off	On	Off	On	On	Off	Off	Off

RLA Factor	Switch Block S1 DIP Switches							
	1	2	3	4	5	6	7	8
0.861248	Off	On	Off	On	On	Off	Off	On
0.862707	Off	On	Off	On	On	Off	On	On
0.864171	Off	On	Off	On	On	On	Off	On
0.865198	Off	On	On	Off	Off	Off	Off	Off
0.865640	Off	On	Off	On	On	On	On	On
0.866670	Off	On	On	Off	Off	Off	Off	On
0.868148	Off	On	On	Off	Off	Off	On	On
0.869631	Off	On	On	Off	Off	On	Off	On
0.871119	Off	On	On	Off	Off	On	On	On
0.871132	Off	On	On	Off	On	Off	Off	Off
0.872625	Off	On	On	Off	On	Off	Off	On
0.874123	Off	On	On	Off	On	Off	On	On
0.875627	Off	On	On	Off	On	On	Off	On
0.877136	Off	On	On	Off	On	On	On	On
0.877189	Off	On	On	On	Off	Off	Off	Off
0.878704	Off	On	On	On	Off	Off	Off	On
0.880223	Off	On	On	On	Off	Off	On	On
0.881748	Off	On	On	On	On	Off	On	Off
0.883278	Off	On	On	On	Off	On	On	On
0.883292	Off	On	On	On	On	Off	Off	Off
0.884828	Off	On	On	On	On	Off	Off	On
0.886369	Off	On	On	On	On	On	Off	On
0.887916	Off	On	On	On	On	On	Off	On
0.889468	Off	On	On	On	On	On	On	On
0.890515	On	Off	Off	Off	Off	Off	Off	Off
0.892076	On	Off	Off	Off	Off	Off	Off	On
0.893643	On	Off	Off	Off	Off	Off	On	On
0.895216	On	Off	Off	Off	Off	On	Off	On
0.896794	On	Off	Off	Off	Off	On	On	On
0.896808	On	Off	Off	Off	On	Off	Off	Off
0.896992	On	Off	Off	Off	On	Off	Off	On
0.899981	On	Off	Off	Off	On	Off	On	On
0.901577	On	Off	Off	Off	On	On	Off	On
0.903178	On	Off	Off	Off	On	On	On	On
0.903234	On	Off	Off	On	Off	Off	Off	Off
0.904841	On	Off	Off	On	Off	Off	Off	On
0.906454	On	Off	Off	On	Off	Off	On	On
0.908073	On	Off	Off	On	Off	On	Off	On
0.909697	On	Off	Off	On	Off	On	On	On
0.909712	On	Off	Off	On	On	Off	Off	Off
0.911342	On	Off	Off	On	On	Off	Off	On
0.912979	On	Off	Off	On	On	Off	On	On
0.914621	On	Off	Off	On	On	On	Off	On
0.916270	On	Off	Off	On	On	On	On	On
0.915773	On	Off	On	Off	Off	Off	Off	Off
0.917426	On	Off	On	Off	Off	Off	Off	On
0.919084	On	Off	On	Off	Off	Off	On	On
0.920749	On	Off	On	Off	Off	On	Off	On
0.922420	On	Off	On	Off	Off	On	On	On
0.922435	On	Off	On	Off	On	Off	Off	Off
0.924112	On	Off	On	Off	On	Off	Off	On
0.925795	On	Off	On	Off	On	Off	On	On
0.927485	On	Off	On	Off	On	On	On	Off
0.929180	On	Off	On	Off	On	On	On	On
0.929241	On	Off	On	On	Off	Off	Off	Off
0.930943	On	Off	On	On	Off	Off	Off	On

Table 5 (Concluded)

RLA Factor	Switch Block S1 DIP Switches							
	1	2	3	4	5	6	7	8
0.932652	On	Off	On	On	Off	Off	On	On
0.934367	On	Off	On	On	Off	On	Off	On
0.936088	On	Off	On	On	Off	On	On	On
0.936103	On	Off	On	On	On	Off	Off	Off
0.937831	On	Off	On	On	On	Off	Off	On
0.939566	On	Off	On	On	On	Off	On	On
0.941307	On	Off	On	On	On	On	Off	On
0.943054	On	Off	On	On	On	On	On	On
0.943922	On	On	Off	Off	Off	Off	Off	Off
0.945680	On	On	Off	Off	Off	Off	Off	On
0.947444	On	On	Off	Off	Off	Off	On	On
0.949214	On	On	Off	Off	Off	On	Off	On
0.950992	On	On	Off	Off	Off	On	On	On
0.951008	On	On	Off	Off	On	Off	Off	Off
0.952792	On	On	Off	Off	On	Off	Off	On
0.954583	On	On	Off	Off	On	Off	On	On
0.956381	On	On	Off	Off	On	On	Off	On
0.958185	On	On	Off	Off	On	On	On	On
0.958249	On	On	Off	On	Off	Off	Off	Off
0.960061	On	On	Off	On	Off	Off	Off	On
0.961880	On	On	Off	On	Off	Off	On	On
0.963706	On	On	Off	On	Off	On	Off	On
0.965539	On	On	Off	On	Off	On	On	On
0.965555	On	On	Off	On	On	Off	Off	Off
0.967395	On	On	Off	On	On	Off	Off	On
0.969242	On	On	Off	On	On	Off	On	On
0.971097	On	On	Off	On	On	On	Off	On
0.972958	On	On	Off	On	On	On	On	On
0.972397	On	On	On	Off	Off	Off	Off	Off
0.974264	On	On	On	Off	Off	Off	Off	On
0.976138	On	On	On	Off	Off	Off	On	On
0.978019	On	On	On	Off	Off	On	Off	On
0.979907	On	On	On	Off	Off	On	On	On
0.979924	On	On	On	Off	On	Off	Off	Off
0.981820	On	On	On	Off	On	Off	Off	On
0.983723	On	On	On	Off	On	Off	On	On
0.985634	On	On	On	Off	On	On	Off	On
0.987553	On	On	On	Off	On	On	On	On
0.987621	On	On	On	On	Off	Off	Off	Off
0.989547	On	On	On	On	Off	Off	Off	On
0.991481	On	On	On	On	Off	Off	On	On
0.993423	On	On	On	On	Off	On	Off	On
0.995372	On	On	On	On	Off	On	On	On
0.995389	On	On	On	On	On	Off	Off	Off
0.997347	On	On	On	On	On	Off	Off	On
0.999312	On	On	On	On	On	Off	On	On
1.001284	On	On	On	On	On	On	Off	On
1.003265	On	On	On	On	On	On	On	On

1. Check the unit nameplate (or design specifications) to establish the chiller's RLA.

2. Determine the appropriate "meter scale" value from Table 4. To do this, compare the unit RLA with the RLA range values in Table 4; select the appropriate RLA range and read across the table to find the corresponding meter scale value.

3. Use the following equation to determine the "RLA factor".

$$\text{RLA Factor} = \frac{\text{RLA} \times 1.4}{\text{Meter Scale}}$$

4. Use Table 5 to find the S1 DIP switch settings that correspond to the RLA factor determined in Step 3. Select the RLA factor in Table 5 that is closest to the RLA factor calculated in Step 3.

5. Compare the DIP switch settings identified in Table 5 (Step 4) with the factory set S1 DIP switch setting combination.

Input Connections (and Terminal Designations)

All electrical connections made at micro module 1U3 are low voltage (i.e., 30 volts AC or less); never connect wires carrying more than 30 volts to terminal strips 1TB6, 1TB3 or 1TB4. Further, never route wiring carrying voltages exceeding 30 volts through the upper half of the unit control panel!

Caution: Connecting any device or wiring that carries more than 30 volts to 1TB6, 1TB3 or 1TB4 will destroy micro module 1U3.

Terminal strip connections for the micro module are illustrated in Figures 4 and 6 of this bulletin and are described in the following paragraphs.

Terminal Strip 1TB6: Bidirectional Communications Link (1TB6-1, -2)

This connection port is provided for a twisted-pair communications link; this link may be used with another machine, or with a higher level control panel (e.g., an SCP system control panel).

Note: Remember that there are no polarity requirements when connecting communication wires.

Terminal Strip 1TB3

Note: See sensor charts section of this bulletin for a breakdown of temperature and pressure input accuracies; only "displayed" accuracies are indicated below.

Leaving Evaporator Water Temperature Sensor (1TB3-1, -2)

Standard thermistor 4RT1, which monitors the temperature of the chilled water leaving the unit, is connected to these terminals.

Sensor and input specifications are as follows:

- [] Operating Range
15 F to 90 F
- [] Displayed Accuracy;
+/- 1.5 F from 20 F thru 70 F
+/- 2.5 F from 70 F thru 90 F and,
+/- 2.5 F from 15 F thru 20 F
- [] Indication
At front panel display (i.e., item "F" of operator's menu).
- [] Open
Diagnostic (on startup bAb)
- [] Shorted
No diagnostic; display reads "---".
- [] Leaving Water Temperature Low Limit
35.3 F for standard-range units only.

Note: The UCM's "differential-to-stop" criteria are typically used to cycle off the chiller - not this "low limit" function! Notice, too, that the "Cooling Required" status indicator light goes out when a "low limit" occurs; no diagnostic is generated.

Entering Evaporator Water Temperature Sensor (1TB3-3, -4)

The optional thermistor (4RT2) connected to these terminals monitors the temperature of the chilled water entering the unit.

Sensor and input specifications are as follows:

- [] Operating Range
15 F to 90 F
- [] Displayed Accuracy
+/- 1.5 F from 20 F to 70 F
+/- 2.5 F from 70 F to 90 F and,
+/- 2.5 F from 15 F to 20 F
- [] Indication
At front panel display (i.e., item "E" of operator's menu).
- [] Shorted
No diagnostic; display reads "---".
- [] Open
No diagnostic; display reads "---".

Spare Temperature Sensors (1TB3-5, -6; 1TB3-7, -8)

Thermistors (i.e., 4RT3 and 4RT4) connected to terminals 5 through 8 on 1TB3 are optional. These "spare temperature" inputs are expected to be used for monitoring entering (1TB3-5, 1TB3-6) and leaving (1TB3-7, 1TB3-8) condenser water temperatures. Actual sensor temperatures can then be viewed on the UCM display (i.e., menu item "H" for entering condenser water, and "J" for leaving condenser water).

Sensor and input specifications are as follow:

- [] Operating Range
30 F to 140 F
- [] Displayed Accuracy
+/- 1.8 F from 60 F to 110 F
+/- 2.5 F from 30 F to 60 F and,
+/- 2.5 F from 110 F to 140 F
- [] Indication
At front panel display (i.e., items "H" and "J" of operator's menu).
- [] Shorted
No diagnostic; display reads "---".
- [] Open
No diagnostic; display reads "---".

Condenser Refrigerant Pressure Transducer (1TB3-9, -10, -11)

This pressure transducer (1R1) is mounted inside the unit control panel and is "T'd" into the condenser gauge line. Transducer output is of the 3-wire, variable resistance type. To assure proper operation, these 3 wires must be connected to terminals 9, 10 and 11 of 1TB3.

Pressure transducer and input specifications follow:

- [] Operating Range
0 psig to 500 psig
- [] Indication
None
- [] Shorted (1TB3-10 TO -11)
Diagnostic b AC
- [] Open
No diagnostic

Evaporator Refrigerant Temperature Sensor (1TB3-12, -13)

This standard thermistor (4RT5) monitors evaporator refrigerant temperature.

Sensor and input specifications follow:

- Operating Range
-5 to 150 F
- Displayed Accuracy
 - +/- 1.0 F at 29.0 F
 - +/- 1.5 F at 30.0 F
 - +/- 2.5 F from 0 F thru 28 F
 - +/- 2.5 F from 31 F thru 34 F
 - +/- 5.5 F from -5 F thru -1 F and,
 - +/- 5.5 F from 35 F thru 40 F

The UCP displays evaporator refrigerant temperatures ranging from -4 F thru 42 F. See "Temperature Sensor Checkout Procedure" in this bulletin for accuracies outside the display range.

- Indication
At front panel display (i.e., item " " of serviceman's menu).
- Shorted
Diagnostic b Ad; must not trip < 150 F
- Open
Diagnostic b Ad; must not trip > -5 F

Ambient Temperature Sensor (1TB3-14, -15)

This optional thermistor (4RT6) is used with the optional, ambient-based, chilled water reset function. A visual indication (i.e., on the UCM's display) of the temperature registered by this sensor is not available.

Sensor and input specifications follow:

- Operating Range
-40 F to 150 F; see sensor conversion data for accuracies.
- Indication
None
- Shorted
Diagnostic b AE; must not trip < 150 F
- Open
No diagnostic

Note: Input terminals 1TB3-14 and -15 are also used when the chiller is controlled by an SCP System Control Panel equipped with the condenser limit option. (For further information, refer to the appropriate SCP installation manual and operator's guide.)

External Inhibit (1TB3-16, -17)

Auxiliary terminal connections for a customer specified or installed non-latching unit start/stop signal. Terminals 1TB3-16 and 1TB3-17 must be jumpered if this external interlock is not used.

Note:

If the unit is supplied with Ice-Making Control, the external inhibit terminals will be occupied by ice-making controls.

Diagnostic A100. Refer to Figures 4 and 6, notice that the unit ships from the factory with a jumper installed between the external inhibit terminals. The unit will not operate unless Terminals 1TB3-16 and 1TB3-17 are shorted.

External inhibit input specifications follow:

- Circuit is monitored by a 12 VDC, 45 mA current.
- Customer-supplied devices connected to these terminals must be compatible with current described above; gold-plated contacts are recommended to avoid oxidation resistance.

Note: Use an isolation relay to limit electrical noise interference, and to reduce the possibility of feeding voltage into micro module 1U3.

Proof of Chilled Water Flow (1TB3-20, -21)

These terminals monitor the status of the chilled water pump relay (1K16) contacts.

If the contacts of 1K16 are closed (i.e., terminals 1TB3-20 and -21 are shorted), proof of closure is signalled by the illumination of the "chilled water flow" status indicator light. (These contacts must only close when there is actually chilled water flow - i.e., both chilled water flow switch 5S2 and auxiliary chilled water pump contactor 5K1 are closed.) A built-in time delay of two seconds (i.e. maximum without flow) is designed to eliminate nuisance tripouts caused by a fluttering flow.

If 1K16's contacts are open, the input at terminals 1TB3-20 and -21 should also be open and the "chilled water flow" status indicator light off. Nonlatching diagnostic b Ed is generated if the chiller switch is set at one of the "Auto" positions and a start-up is attempted at this time. (The UCM will not generate a b Ed diagnostic if the chiller switch is set at "Standby/Reset".)

Note: 1K16's contacts must open whenever the chilled water flow rate is either below the minimum acceptable level, or nonexistent (i.e., 5S2 or 5K1 are open).

Remember that the customer-supplied flow/pressure switch and pump interlock circuit must be connected to terminals 1TB7-5 and 1TB7-3 in the high-voltage section of the unit control panel; this circuit powers chilled water pump relay 1K16.

Caution: Do not connect the 120V flow switch interlock circuit to terminals 1TB3-20 and -21, or micro module 1U3 will be damaged.

Proof of Condenser Water Flow (1TB3-22, -23)

These terminals monitor the status of the condenser water pump relay (1K17) contacts.

If the contacts of 1K17 are closed (i.e., input terminals 1TB3-22 and -23 are shorted), proof of closure is signalled by advancement from operating code A 71 (i.e., "establish condenser water flow") to A 72 (i.e., "start").

Note: 1K17's contacts must only close when there is actually condenser water flow (i.e., proven by closure of both condenser water flow switch 5S3 and auxiliary condenser water pump contactor 5K2).

If 1K17's contacts are open, the input at terminals 1TB3-22 and -23 should also be open. In the event that condenser water flow is lost during chiller operation, the unit is shut down on nonlatching diagnostic b F7 and a restart is attempted. Latching diagnostic b dC is generated if condenser water flow is not established within 3 minutes of initiation of operating mode A 71.

Note: 1K17's contacts must open whenever condenser water flow is either below the minimum acceptable rate, or nonexistent (i.e. both 5S3 and 5K2 are open).

Remember that the customer-supplied flow/pressure switch and pump interlock circuit must be connected to terminals 1TB7-6 and 1TB7-4 in the high-voltage section of the unit control panel; this circuit powers condenser water pump relay 1K17.

Caution: Do not connect the 120V flow switch interlock circuit to terminals 1TB3-22 and -23, or micro module 1U3 will be damaged beyond repair.

Low Pressure Cutout (1TB3-24, -25)

These terminals monitor the pressure in the evaporator. If the pressure falls below 45 +/- 10 psig for design sequence A thru E closure of 4S6 between 1TB3-24 and 1TB3-25 will shut down the unit giving a latching diagnostic (b b5). For design sequence F and on the low pressure cutout is 26 +/- 10 psig.

Terminal Strip 1TB4

Proving Oil Flow (1TB4-1, -2)

Sufficient oil flow through bearing oil supply system must be confirmed within 30 seconds by closing oil flow switch 4S5, or unit locks out on low oil flow b F2.

Note: If 4S5 is closed before compressor start-up, b E8 is displayed. This checks for an oil flow switch that is not functioning properly.

Running External Interlock (1TB4-3, -4)

Terminals 3 and 4 of 1TB4 accept a switch input that indicates a system fault (i.e., detected by a customer-supplied remote device) requiring a unit shutdown. This function is only active when the unit is running and transition is complete.

Notice that as long as the micro "sees" an open input at Terminals 3 and 4, no fault is detected. If the input is shorted, however, a fault requiring unit shutdown occurred, and micro module 1U3 responds by initiating latching diagnostic condition b F1. Unit requires manual reset.

Specifications for the running external interlock input are as follows:

- [] This fault circuit is monitored by a 12 VDC, 45 mA current.
- [] Customer-supplied devices connected to these terminals must be compatible with the current described above; gold-plated contacts are recommended to avoid oxidation resistance.

Notes: Use an isolation relay to limit noise interference, and to reduce the possibility of feeding voltage into micro module 1U3.

"Transition Complete" Contacts (1TB4-5, -6)

This terminal input allows the micro module to monitor the main run starter contactor (2K2) to determine whether transition has occurred. A shorted input indicates that transition is complete, while an open input "tells" the micro that transition is not occurred.

Note: The shield wire must be taped off at the 2K2 contacts and grounded to a ground lug provided in the starter panel (i.e., at the 2TB1 terminal strip end of these leads). These leads are not shielded between the starter panel and unit control panel.

Following is the specification for the "transition complete" input to micro module 1U3:

- [] The "transition complete" circuit is monitored by a 12 VDC, 45 mA current.

3-Phase Current-Sensing Input (1TB4-7 thru -12)

These 6 terminals accept 3 AC signal inputs that are representative of the compressor motor's AC current draw. Line current is stepped down by 2 sets of current transformers. Each set of current transformers contains 3 transformers; the first steps the line current down to a 0-5 amp signal, and the second further steps down the 0-5 amp signal to a milliamper (mA) signal.

Caution: Do not connect the 0-5 amp output signal of the primary transformer directly to micro module 1U3, or destruction of the module will result.

Following are specifications for the 3-phase current-sensing input:

- [] Overall Accuracy
5 to 140 +/- 5% RLA
- [] Open
Diagnostic b E2 (i.e., momentary power loss), diagnostic b E4 (i.e., phase loss), or diagnostic b E5 (i.e., phase reversal).

Connections at terminals 7 through 12 are as follows:

- [] Terminals 1TB4-7 and -8 are connected to secondary transformer 2T7 on L3.
- [] Terminals 1TB4-9 and -10 are connected to secondary transformer 2T6 on L2.
- [] Terminals 1TB4-11 and -12 are connected to secondary transformer 2T5 on L1.

Note: It is essential that the correct polarity is maintained in all current transformer connections. Consult the appropriate starter wiring diagram to confirm that proper connection polarity is established.

Discharge Temp Sensor (1TB4-19, -20)

The temperature sensor that monitors compressor discharge temperature (i.e., thermistor 4RT8) is connected to these terminals.

Note: Remember that the discharge temperature setting is not adjustable.

Specifications for the discharge temperature sensor input are as follows:

- [] Operating Range
40 F to 250 F
- [] Shorted
Diagnostic b A9; must not trip < 195 F
- [] Open
Diagnostic b A9; must not trip > 90 F
- [] Discharge Temp Sensor "Off" Point
205 F; results in a latching diagnostic b 80

Motor Winding Temperature Sensors (1TB4-15 thru -18)

The leads of the 3 temperature sensors (4B1R2, 4B1R3, 4B1R4) buried in the compressor motor windings are connected to these input terminals. Check the unit wiring diagram to properly identify individual sensor wires.

Note: Notice that the "common" leg of each sensor is connected to terminal 1TB4-17.

Specifications for the motor winding temperature sensor inputs are as follows:

- [] Operating Range
50 F to 310 +/- 5 F
- [] Open
Diagnostic b A4, b A7 or b A8, as applicable
- [] Shorted
No diagnostic
- [] Winding Temp \geq 165 F - 5 min
Start Delay (operating code A70)
- [] Winding Temp \leq 165 F - 2 min
Start Delay (operating code A70)
- [] Trip Point Temp = 265 +/- 5 F

Temperature Sensor Checkout Procedure

With the exception of the resistance sensors embedded in the compressor motor windings, all of the temperature sensors used with the UCM (i.e., unit control module) are thermistors. Micro module 1U3 "reads" the temperature at each sensor by sending a current through it and then measuring the voltage that develops across the sensor.

Use the procedure described below to check the thermistors and micro module (1U3) for proper operation:

WARNING: To prevent injury or death due to electrical shock, use care when measurements, adjustments, or other service-related operations are performed with power on.

Note: Micro module sensor inputs are "slew-rate limited"; because of this, they may respond slowly to changes in temperature. When using the diagnostic procedure described below, be certain that the temperature reading is stable.

1. Measure the temperature at the sensor using an accurate thermometer; record the temperature reading observed.
2. With the sensor leads connected to micro module 1U3, and 1U3 powered, measure the DC voltage across the sensor leads at the terminal strip; record the voltage observed.

Note: Always use a meter with a 10-megohm (or greater) input resistance to avoid interference with sensor resistance. Using a meter with a smaller input resistance will result in misleading voltage/resistance variances.

3. Select the appropriate sensor from Tables 6 through 12. Then, compare the temperature (in the table) corresponding to the voltage reading recorded in Step 2 with the actual temperature observed in Step 1. If the actual temperature measured falls within the allowable tolerance range, both the sensor and micro module 1U3 are operating properly. However, if the actual temperature is outside the allowable sensor tolerance range, proceed to Step 4.
4. Again, measure the temperature at the sensor with an accurate thermometer; record the temperature reading observed.
5. Remove the sensor leads from the 1U3 terminal strip and measure the resistance through the sensor with a digital volt-ohmmeter. Record the resistance observed.
6. Select the appropriate sensor table at the end of this section and locate the resistance value recorded in Step 5. Verify that the temperature corresponding to this resistance value matches (i.e., within the tolerance range specified for that sensor) the temperature measured with the thermometer in Step 4.

If the sensor temperature is out of range, replace the sensor. However, if the sensor temperature is within tolerance while the temperature determined by the voltage reading in Steps 1 through 3 is out of tolerance, micro module 1U3 is defective and must be replaced.

Table 6
Sensor Conversion Data:
Optional Condenser Refrigerant
Pressure (1R1) on RTHA

Actual Pressure (Psig)	Actual Resistance (Ohms)		Input Voltage at 1783-10, -11 (Volts)
	1783-10, -11	1783-9, -10	
0.000	8000.000	2000.000	4.356436
4.000	7940.000	2060.000	4.323763
8.000	7880.000	2120.000	4.291089
12.000	7820.000	2180.000	4.258416
16.000	7760.000	2240.000	4.225742
20.000	7700.000	2300.000	4.193069
24.000	7640.000	2360.000	4.160396
28.000	7580.000	2420.000	4.127723
32.000	7520.000	2480.000	4.095050
36.000	7460.000	2540.000	4.062376
40.000	7400.000	2600.000	4.029703
44.000	7340.000	2660.000	3.997030
48.000	7280.000	2720.000	3.964356
52.000	7220.000	2780.000	3.931683
56.000	7160.000	2840.000	3.899010
60.000	7100.000	2900.000	3.866337
64.000	7040.000	2960.000	3.833663
68.000	6980.000	3020.000	3.800990
72.000	6920.000	3080.000	3.768317
76.000	6860.000	3140.000	3.735644
80.000	6800.000	3200.000	3.702970
84.000	6740.000	3260.000	3.670297
88.000	6680.000	3320.000	3.637624
92.000	6620.000	3380.000	3.604950
96.000	6560.000	3440.000	3.572277
100.000	6500.000	3500.000	3.539604
104.000	6440.000	3560.000	3.506931
108.000	6380.000	3620.000	3.474257
112.000	6320.000	3680.000	3.441585
116.000	6260.000	3740.000	3.408911
120.000	6200.000	3800.000	3.376238
124.000	6140.000	3860.000	3.343564
128.000	6080.000	3920.000	3.310891
132.000	6020.000	3980.000	3.278218
136.000	5960.000	4040.000	3.245545
140.000	5900.000	4100.000	3.212872
144.000	5840.000	4160.000	3.180198
148.000	5780.000	4220.000	3.147525
152.000	5720.000	4280.000	3.114852
156.000	5660.000	4340.000	3.082178
160.000	5600.000	4400.000	3.049505
164.000	5540.000	4460.000	3.016832
168.000	5480.000	4520.000	2.984159
172.000	5420.000	4580.000	2.951485
176.000	5360.000	4640.000	2.918812
180.000	5300.000	4700.000	2.886139
184.000	5240.000	4760.000	2.853466
188.000	5180.000	4820.000	2.820792
192.000	5120.000	4880.000	2.788119
196.000	5060.000	4940.000	2.755446

Actual Pressure (Psig)	Actual Resistance (Ohms)		Input Voltage at 1783-10, -11 (Volts)
	1783-10, -11	1783-9, -10	
200.000	5000.000	5000.000	2.722772
204.000	4940.000	5060.000	2.690099
208.000	4880.000	5120.000	2.657426
212.000	4820.000	5180.000	2.624753
216.000	4760.000	5240.000	2.592079
220.000	4700.000	5300.000	2.559406
224.000	4640.000	5360.000	2.526733
228.000	4580.000	5420.000	2.494059
232.000	4520.000	5480.000	2.461386
236.000	4460.000	5540.000	2.428713
240.000	4400.000	5600.000	2.396039
244.000	4340.000	5660.000	2.363366
248.000	4280.000	5720.000	2.330693
252.000	4220.000	5780.000	2.298020
256.000	4160.000	5840.000	2.265347
260.000	4100.000	5900.000	2.232673
264.000	4040.000	5960.000	2.200000
268.000	3980.000	6020.000	2.167327
272.000	3920.000	6080.000	2.134654
276.000	3860.000	6140.000	2.101980
280.000	3800.000	6200.000	2.069307
284.000	3740.000	6260.000	2.036634
288.000	3680.000	6320.000	2.003960
292.000	3620.000	6380.000	1.971287
296.000	3560.000	6440.000	1.938614
300.000	3500.000	6500.000	1.905941
304.000	3440.000	6560.000	1.873267
308.000	3380.000	6620.000	1.840594
312.000	3320.000	6680.000	1.807921
316.000	3260.000	6740.000	1.775248
320.000	3200.000	6800.000	1.742574
324.000	3140.000	6860.000	1.709901
328.000	3080.000	6920.000	1.677228
332.000	3020.000	6980.000	1.644555
336.000	2960.000	7040.000	1.611881
340.000	2900.000	7100.000	1.579208
344.000	2840.000	7160.000	1.546535
348.000	2780.000	7220.000	1.513861
352.000	2720.000	7280.000	1.481188
356.000	2660.000	7340.000	1.448515
360.000	2600.000	7400.000	1.415842
364.000	2540.000	7460.000	1.383168
368.000	2480.000	7520.000	1.350495
372.000	2420.000	7580.000	1.317822
376.000	2360.000	7640.000	1.285149
380.000	2300.000	7700.000	1.252475
384.000	2240.000	7760.000	1.219802
388.000	2180.000	7820.000	1.187129
392.000	2120.000	7880.000	1.154456
396.000	2060.000	7940.000	1.121782
400.000	2000.000	8000.000	1.089109

Table 7
Sensor Conversion Data:
Evaporator Leaving Water Temperature (4RT1)
Optional Evaporator Entering Water Temperature (4RT2)

Actual Temp. (F)	Actual Resistance (Ohms)	Thermistor Voltage (Note 3)	Actual Temp. (F)	Actual Resistance (Ohms)	Thermistor Voltage (Note 3)
15.000	54,635.59	4.236	53.000	18,420.49	2.992
16.000	52,987.21	4.208	54.000	17,939.01	2.957
17.000	51,393.36	4.180	55.000	17,471.74	2.922
18.000	49,852.12	4.152	56.000	17,018.23	2.887
19.000	48,361.55	4.123	57.000	16,578.03	2.852
20.000	46,919.86	4.094	58.000	16,150.71	2.817
21.000	45,525.32	4.064	59.000	15,735.84	2.782
22.000	44,176.24	4.034	60.000	15,333.03	2.747
23.000	42,871.04	4.004	61.000	14,941.88	2.713
24.000	41,608.12	3.973	62.000	14,562.03	2.678
25.000	40,386.01	3.942	63.000	14,193.10	2.643
26.000	39,203.26	3.911	64.000	13,834.75	2.609
27.000	38,058.56	3.879	65.000	13,486.65	2.575
28.000	36,950.50	3.847	66.000	13,148.46	2.541
29.000	35,877.84	3.814	67.000	12,819.88	2.507
30.000	34,839.39	3.782	68.000	12,500.59	2.473
31.000	33,833.91	3.749	69.000	12,190.32	2.440
32.000	32,861.74	3.715	70.000	11,888.77	2.406
33.000	31,935.73	3.683	71.000	11,595.68	2.373
34.000	31,039.07	3.649	72.000	11,310.78	2.340
35.000	30,170.77	3.616	73.000	11,033.81	2.308
36.000	29,329.83	3.582	74.000	10,764.53	2.275
37.000	28,515.28	3.549	75.000	10,502.71	2.243
38.000	27,726.22	3.515	76.000	10,248.11	2.211
39.000	26,961.78	3.481	77.000	10,000.51	2.179
40.000	26,221.09	3.446	78.000	9,759.70	2.148
41.000	25,503.33	3.412	79.000	9,525.47	2.117
42.000	24,807.73	3.377	80.000	9,297.62	2.086
43.000	24,133.52	3.343	81.000	9,075.96	2.055
44.000	23,479.98	3.308	82.000	8,860.30	2.024
45.000	22,846.40	3.273	83.000	8,650.45	1.994
46.000	22,232.11	3.238	84.000	8,446.26	1.964
47.000	21,636.47	3.203	85.000	8,247.54	1.935
48.000	21,058.83	3.168	86.000	8,054.13	1.906
49.000	20,498.61	3.133	87.000	7,865.87	1.877
50.000	19,955.21	3.098	88.000	7,682.62	1.848
51.000	19,428.09	3.062	89.000	7,504.22	1.820
52.000	18,916.69	3.027	90.000	7,330.53	1.791

Notes:

1. Sensor 4RT1 is connected between Terminals 1TB3-1 and -2 on micro module 1U3; optional sensor 4RT2 is connected between Terminals 1TB3-3 and -4.

2. Overall accuracy for sensors 4RT1 and 4RT2 is as follows:

- ± 1 F from 20 F to 70 F;
- ± 2 F from 70 F to 90 F; and,
- ± 2 F from 15 F to 20 F.

3. As you compare a thermistor resistance (or input voltage) reading with the "actual" temperature indicated by the thermometer, be sure to consider the precision of the thermometer when you decide whether or not the thermistor is out of range.

Table 8
Sensor Conversion Data:
Optional Condenser Entering (4RT3) and
Leaving (4RT4) Water Temperature

Actual Temp. (F)	Actual Resistance (Ohms)	Thermistor Voltage (Note 3)	Actual Temp. (F)	Actual Resistance (Ohms)	Thermistor Voltage (Note 3)
30.000	34,839.39	4.553	65.000	13,486.65	3.642
31.000	33,833.91	4.532	66.000	13,148.46	3.612
32.000	32,861.74	4.511	67.000	12,819.88	3.581
33.000	31,935.73	4.489	68.000	12,500.59	3.551
34.000	31,039.07	4.467	69.000	12,190.32	3.520
35.000	30,170.77	4.445	70.000	11,888.77	3.489
36.000	29,329.83	4.422	71.000	11,595.68	3.458
37.000	28,515.28	4.399	72.000	11,310.78	3.427
38.000	27,726.22	4.376	73.000	11,033.81	3.396
39.000	26,961.78	4.352	74.000	10,764.53	3.364
40.000	26,221.09	4.327	75.000	10,502.71	3.333
41.000	25,503.33	4.304	76.000	10,248.11	3.302
42.000	24,807.73	4.280	77.000	10,000.51	3.270
43.000	24,133.52	4.255	78.000	9,759.70	3.238
44.000	23,479.98	4.230	79.000	9,525.47	3.207
45.000	22,846.40	4.205	80.000	9,297.62	3.175
46.000	22,232.11	4.179	81.000	9,075.96	3.143
47.000	21,636.47	4.153	82.000	8,860.30	3.112
48.000	21,058.83	4.127	83.000	8,650.45	3.080
49.000	20,498.61	4.100	84.000	8,446.26	3.048
50.000	19,955.21	4.073	85.000	8,247.52	3.016
51.000	19,428.09	4.046	86.000	8,054.13	2.985
52.000	18,916.69	4.019	87.000	7,865.87	2.953
53.000	18,420.49	3.991	88.000	7,682.62	2.921
54.000	17,939.01	3.963	89.000	7,504.22	2.890
55.000	17,471.74	3.935	90.000	7,330.53	2.859
56.000	17,018.23	3.907	91.000	7,161.41	2.827
57.000	16,578.03	3.878	92.000	6,996.74	2.795
58.000	16,150.71	3.850	93.000	6,836.36	2.764
59.000	15,735.84	3.820	94.000	6,680.17	2.733
60.000	15,333.03	3.791	95.000	6,528.05	2.702
61.000	14,941.88	3.762	96.000	6,379.86	2.671
62.000	14,562.03	3.732	97.000	6,235.50	2.640
63.000	14,193.10	3.702	98.000	6,094.87	2.609
64.000	13,834.75	3.672	99.000	5,957.84	2.578

Actual Temp. (F)	Actual Resistance (Ohms)	Thermistor Voltage (Note 3)	Actual Temp. (F)	Actual Resistance (Ohms)	Thermistor Voltage (Note 3)
100.000	5,824.32	2.548	120.000	3,756.95	1.973
101.000	5,694.22	2.517	121.000	3,678.12	1.947
102.000	5,567.42	2.487	122.000	3,601.11	1.921
103.000	5,443.84	2.457	123.000	3,526.48	1.895
104.000	5,323.39	2.427	124.000	3,453.62	1.869
105.000	5,205.97	2.397	125.000	3,382.47	1.844
106.000	5,091.51	2.368	126.000	3,313.00	1.819
107.000	4,979.91	2.338	127.000	3,245.16	1.794
108.000	4,871.11	2.309	128.000	3,178.90	1.769
109.000	4,765.02	2.280	129.000	3,114.19	1.745
110.000	4,661.56	2.251	130.000	3,050.99	1.721
111.000	4,560.67	2.222	131.000	2,989.25	1.697
112.000	4,462.27	2.194	132.000	2,928.94	1.673
113.000	4,366.29	2.165	133.000	2,870.02	1.650
114.000	4,272.67	2.137	134.000	2,812.45	1.627
115.000	4,181.34	2.109	135.000	2,756.20	1.604
116.000	4,092.24	2.082	136.000	2,701.24	1.581
117.000	4,005.31	2.054	137.000	2,647.54	1.559
118.000	3,920.49	2.027	138.000	2,595.05	1.536
119.000	3,837.72	2.000	139.000	2,543.76	1.515
			140.000	2,493.62	1.493

Notes:

- Optional sensor 4RT3 is connected between Terminals 1TB3-5 and -6 on micro module 1U3, while sensor 4RT4 is connected between 1TB3-7 and -8.
- Overall accuracy for sensors 4RT3 and 4RT4 is as follows:
 ± 1 F from 60 F to 110 F;
 ± 2 F from 30 F to 60 F; and,
 ± 2 F from 110 F to 140 F.
- As you compare a thermistor resistance (or input voltage) reading with the "actual" temperature indicated by the thermometer, be sure to consider the precision of the thermometer when you decide whether or not the thermistor is out of range.

Table 9
Sensor Conversion Data:
Evaporator Refrigerant Temperature (4RT5)

Actual Temp. (F)	Actual Resistance (Ohms)	Thermistor Voltage (Note 3)	Actual Temp. (F)	Actual Resistance (Ohms)	Thermistor Voltage (Note 3)	Actual Temp. (F)	Actual Resistance (Ohms)	Thermistor Voltage (Note 3)	Actual Temp. (F)	Actual Resistance (Ohms)	Thermistor Voltage (Note 3)
-5.000	102,906.40	4.082	75.000	10,502.71	1.379	35.000	30,170.77	2.655	115.000	4,181.34	0.652
-4.000	99,604.04	4.052	76.000	10,248.11	1.354	36.000	29,329.83	2.618	116.000	4,092.24	0.640
-3.000	96,417.76	4.022	77.000	10,000.51	1.330	37.000	28,515.28	2.581	117.000	4,005.31	0.628
-2.000	93,343.04	3.991	78.000	9,759.70	1.305	38.000	27,726.22	2.545	118.000	3,920.49	0.616
-1.000	90,375.79	3.960	79.000	9,525.47	1.282	39.000	26,961.78	2.508	119.000	3,837.72	0.604
+0.000	87,511.82	3.928	80.000	9,297.62	1.258	40.000	26,221.09	2.471	120.000	3,756.95	0.593
1.000	84,747.29	3.896	81.000	9,075.96	1.235	41.000	25,503.33	2.435	121.000	3,678.12	0.582
2.000	82,078.42	3.864	82.000	8,860.30	1.213	42.000	24,807.73	2.399	122.000	3,601.11	0.571
3.000	79,501.66	3.831	83.000	8,650.45	1.191	43.000	24,133.52	2.363	123.000	3,526.48	0.561
4.000	77,013.47	3.798	84.000	8,446.26	1.169	44.000	23,479.98	2.328	124.000	3,453.62	0.550
5.000	74,610.62	3.764	85.000	8,247.54	1.147	45.000	22,846.40	2.292	125.000	3,382.47	0.540
6.000	72,290.00	3.730	86.000	8,054.13	1.126	46.000	22,232.11	2.257	126.000	3,313.00	0.530
7.000	70,048.44	3.700	87.000	7,865.87	1.105	47.000	21,636.47	2.222	127.000	3,245.16	0.520
8.000	67,883.04	3.661	88.000	7,682.62	1.085	48.000	21,058.83	2.187	128.000	3,178.90	0.511
9.000	65,790.95	3.626	89.000	7,504.22	1.065	49.000	20,498.61	2.153	129.000	3,114.19	0.501
10.000	63,769.60	3.591	90.000	7,330.53	1.045	50.000	19,955.21	2.119	130.000	3,050.99	0.492
11.000	61,816.30	3.555	91.000	7,161.41	1.026	51.000	19,428.09	2.085	131.000	2,989.25	0.483
12.000	59,928.60	3.520	92.000	6,996.74	1.007	52.000	18,916.69	2.052	132.000	2,928.94	0.474
13.000	58,104.07	3.484	93.000	6,836.36	0.988	53.000	18,420.49	2.019	133.000	2,870.02	0.466
14.000	56,340.49	3.447	94.000	6,680.17	0.970	54.000	17,939.01	1.986	134.000	2,812.45	0.457
15.000	54,635.59	3.411	95.000	6,528.05	0.951	55.000	17,471.74	1.953	135.000	2,756.20	0.449
16.000	52,987.21	3.374	96.000	6,379.86	0.934	56.000	17,018.23	1.921	136.000	2,701.24	0.440
17.000	51,393.36	3.337	97.000	6,235.50	0.916	57.000	16,578.03	1.889	137.000	2,647.54	0.432
18.000	49,852.12	3.300	98.000	6,094.87	0.899	58.000	16,150.71	1.858	138.000	2,595.05	0.425
19.000	48,361.55	3.262	99.000	5,957.84	0.882	59.000	15,735.84	1.827	139.000	2,543.76	0.417
20.000	46,919.66	3.225	100.000	5,824.32	0.866	60.000	15,333.03	1.796	140.000	2,493.62	0.409
21.000	45,525.32	3.187	101.000	5,694.22	0.850	61.000	14,941.88	1.766	141.000	2,444.62	0.402
22.000	44,176.24	3.149	102.000	5,567.42	0.834	62.000	14,562.03	1.736	142.000	2,396.72	0.395
23.000	42,871.04	3.111	103.000	5,443.84	0.818	63.000	14,193.10	1.706	143.000	2,349.89	0.387
24.000	41,608.12	3.073	104.000	5,323.39	0.803	64.000	13,834.75	1.677	144.000	2,304.11	0.380
25.000	40,386.01	3.035	105.000	5,205.97	0.788	65.000	13,486.65	1.648	145.000	2,259.35	0.374
26.000	39,203.26	3.000	106.000	5,091.51	0.773	66.000	13,148.46	1.619	146.000	2,215.59	0.367
27.000	38,058.56	2.959	107.000	4,979.91	0.758	67.000	12,819.88	1.591	147.000	2,172.80	0.360
28.000	36,950.50	2.920	108.000	4,871.11	0.744	68.000	12,500.59	1.563	148.000	2,130.95	0.354
29.000	35,877.84	2.882	109.000	4,765.02	0.730	69.000	12,190.32	1.536	149.000	2,090.03	0.347
30.000	34,839.39	2.844	110.000	4,661.56	0.717	70.000	11,888.77	1.508	150.000	2,050.01	0.341
31.000	33,833.91	2.806	111.000	4,560.67	0.703	71.000	11,595.68	1.482			
32.000	32,861.74	2.768	112.000	4,462.27	0.690	72.000	11,310.78	1.455			
33.000	31,935.73	2.730	113.000	4,366.29	0.677	73.000	11,033.81	1.429			
34.000	31,039.07	2.693	114.000	4,272.67	0.664	74.000	10,764.53	1.404			

Notes:

- Sensor 4RT5 is connected between terminals 1TB3-12 and -13 on micro module 1U3.
- Overall accuracy of sensor 4RT5 is as follows:
 ± 0.60 F at 29.0 F;
 ± 1.0 F at 30.0 F;
 ± 2.0 F from 0 F to 28 F, and from 31 F to 34 F;
 ± 5.0 F from -10 F to -1 F, and from +35 F to 70 F.
- As you compare a thermistor resistance (or input voltage) reading with the "actual" temperature indicated by the thermometer, be sure to consider the precision of the thermometer when you decide whether or not the thermistor is out of range.

Table 10
Sensor Conversion Data:
Optional Ambient Temperature (4RT6)

Actual Temp. (F)	Actual Resistance (Ohms)	Thermistor Voltage (Note 3)	Actual Temp. (F)	Actual Resistance (Ohms)	Thermistor Voltage (Note 3)	Actual Temp. (F)	Actual Resistance (Ohms)	Thermistor Voltage (Note 3)	Actual Temp. (F)	Actual Resistance (Ohms)	Thermistor Voltage (Note 3)
- 5.000	102,906.40	4.449	65.000	13,486.65	1.963	30.000	34,839.39	3.240	100.000	5,824.32	1.063
- 4.000	99,604.04	4.421	66.000	13,148.46	1.931	31.000	33,833.91	3.201	101.000	5,694.22	1.044
- 3.000	96,417.76	4.393	67.000	12,819.88	1.900	32.000	32,861.74	3.162	102.000	5,567.42	1.025
- 2.000	93,343.04	4.364	68.000	12,500.59	1.868	33.000	31,935.73	3.123	103.000	5,443.84	1.007
- 1.000	90,375.79	4.335	69.000	12,190.32	1.837	34.000	31,039.07	3.085	104.000	5,323.39	0.988
+ 0.000	87,511.82	4.305	70.000	11,888.77	1.807	35.000	30,170.77	3.046	105.000	5,205.97	0.970
1.000	84,747.29	4.274	71.000	11,595.68	1.777	36.000	29,329.83	3.008	106.000	5,091.51	0.953
2.000	82,078.42	4.244	72.000	11,310.78	1.747	37.000	28,515.28	2.969	107.000	4,979.91	0.935
3.000	79,501.66	4.212	73.000	11,033.81	1.718	38.000	27,726.22	2.931	108.000	4,871.11	0.918
4.000	77,013.47	4.181	74.000	10,764.53	1.688	39.000	26,961.78	2.893	109.000	4,765.02	0.902
5.000	74,610.62	4.149	75.000	10,502.71	1.660	40.000	26,221.09	2.855	110.000	4,661.56	0.885
6.000	72,290.00	4.116	76.000	10,248.11	1.631	41.000	25,503.33	2.816	111.000	4,560.67	0.869
7.000	70,048.44	4.083	77.000	10,000.51	1.604	42.000	24,807.73	2.778	112.000	4,462.27	0.853
8.000	67,883.04	4.050	78.000	9,759.70	1.576	43.000	24,133.52	2.741	113.000	4,366.29	0.838
9.000	65,790.95	4.016	79.000	9,525.47	1.549	44.000	23,479.98	2.703	114.000	4,272.67	0.822
10.000	63,769.60	3.982	80.000	9,297.62	1.522	45.000	22,846.40	2.665	115.000	4,181.34	0.807
11.000	61,816.30	3.948	81.000	9,075.96	1.496	46.000	22,232.11	2.628	116.000	4,092.24	0.793
12.000	59,928.60	3.913	82.000	8,860.30	1.470	47.000	21,636.47	2.591	117.000	4,005.31	0.778
13.000	58,104.07	3.878	83.000	8,650.45	1.444	48.000	21,058.83	2.553	118.000	3,920.49	0.764
14.000	56,340.49	3.843	84.000	8,446.26	1.419	49.000	20,498.61	2.517	119.000	3,837.72	0.750
15.000	54,635.59	3.807	85.000	8,247.54	1.394	50.000	19,955.21	2.480	120.000	3,756.95	0.736
16.000	52,987.21	3.771	86.000	8,054.13	1.369	51.000	19,428.09	2.444	121.000	3,678.12	0.723
17.000	51,393.36	3.734	87.000	7,865.87	1.345	52.000	18,916.69	2.407	122.000	3,601.11	0.710
18.000	49,852.12	3.698	88.000	7,682.62	1.321	53.000	18,420.49	2.372	123.000	3,526.48	0.697
19.000	48,361.55	3.661	89.000	7,504.22	1.300	54.000	17,939.01	2.336	124.000	3,453.62	0.684
20.000	46,919.86	3.623	90.000	7,330.53	1.275	55.000	17,471.74	2.300	125.000	3,382.47	0.672
21.000	45,525.32	3.590	91.000	7,161.41	1.252	56.000	17,018.23	2.265	126.000	3,313.00	0.660
22.000	44,176.24	3.548	92.000	6,996.74	1.230	57.000	16,578.03	2.231	127.000	3,245.16	0.648
23.000	42,871.04	3.510	93.000	6,836.36	1.208	58.000	16,150.71	2.196	128.000	3,178.90	0.636
24.000	41,608.12	3.472	94.000	6,680.17	1.186	59.000	15,735.84	2.162	129.000	3,114.19	0.625
25.000	40,386.01	3.434	95.000	6,528.05	1.165	60.000	15,333.03	2.128	130.000	3,050.99	0.614
26.000	39,203.26	3.395	96.000	6,379.86	1.144	61.000	14,941.88	2.094	131.000	2,989.25	0.602
27.000	38,058.56	3.357	97.000	6,235.50	1.123	62.000	14,562.03	2.061	132.000	2,928.94	0.592
28.000	36,950.50	3.318	98.000	6,094.87	1.103	63.000	14,193.10	2.028	133.000	2,870.02	0.581
29.000	35,877.84	3.279	99.000	5,957.84	1.083	64.000	13,834.75	1.995	134.000	2,812.45	0.571
									135.000	2,756.20	0.560

Notes:

- Optional sensor 4RT6 is connected between Terminals 17B3-14 and -15 on micro module 1U3.
- Overall accuracy of sensor 4RT6 is as follows:
 + 3 F from 0 F to 70 F;
 + 5 F from -5 F to 0 F; and,
 + 8 F from 70 F to 135 F.
- As you compare a thermistor resistance (or input voltage) reading with the "actual" temperature indicated by the thermometer, be sure to consider the precision of the thermometer when you decide whether or not the thermistor is out of range.

Table 11
Sensor Conversion Data:
Discharge Temperature 4RT8

Actual Temp. (F)	Actual Resistance (Ohms)	Thermistor Voltage (Note 3)	Actual Temp. (F)	Actual Resistance (Ohms)	Thermistor Voltage (Note 3)
32.000	32,861.74	5.211	107.000	4,979.91	4.028
33.000	31,935.73	5.203	108.000	4,871.11	4.004
34.000	31,039.07	5.195	109.000	4,765.02	3.980
35.000	30,170.77	5.187	110.000	4,661.56	3.956
36.000	29,329.83	5.179	111.000	4,560.67	3.931
37.000	28,515.28	5.170	112.000	4,462.27	3.907
38.000	27,726.22	5.161	113.000	4,366.29	3.882
39.000	26,961.78	5.152	114.000	4,272.67	3.857
40.000	26,221.09	5.143	115.000	4,181.34	3.832
41.000	25,503.33	5.134	116.000	4,092.24	3.807
42.000	24,807.73	5.124	117.000	4,005.31	3.782
43.000	24,133.52	5.114	118.000	3,920.49	3.756
44.000	23,479.98	5.104	119.000	3,837.72	3.731
45.000	22,846.40	5.094	120.000	3,756.95	3.705
46.000	22,232.11	5.084	121.000	3,678.12	3.679
47.000	21,636.47	5.073	122.000	3,601.11	3.654
48.000	21,058.83	5.062	123.000	3,526.48	3.628
49.000	20,498.61	5.051	124.000	3,453.62	3.602
50.000	19,955.21	5.040	125.000	3,382.47	3.580
51.000	19,428.09	5.029	126.000	3,313.00	3.550
52.000	18,916.69	5.017	127.000	3,245.16	3.524
53.000	18,420.49	5.005	128.000	3,178.90	3.498
54.000	17,939.01	4.993	129.000	3,114.19	3.471
55.000	17,471.74	4.981	130.000	3,050.99	3.445
56.000	17,018.23	4.969	131.000	2,989.25	3.419
57.000	16,578.03	4.956	132.000	2,928.94	3.392
58.000	16,150.71	4.943	133.000	2,870.02	3.366
59.000	15,735.84	4.930	134.000	2,812.45	3.339
60.000	15,333.03	4.916	135.000	2,756.20	3.313
61.000	14,941.88	4.903	136.000	2,701.24	3.286
62.000	14,562.03	4.889	137.000	2,647.54	3.259
63.000	14,193.10	4.875	138.000	2,595.05	3.233
64.000	13,834.75	4.861	139.000	2,543.76	3.206
65.000	13,486.65	4.846	140.000	2,493.62	3.179
66.000	13,148.46	4.831	141.000	2,444.62	3.153
67.000	12,819.88	4.816	142.000	2,396.72	3.126
68.000	12,500.59	4.801	143.000	2,349.89	3.099
69.000	12,190.32	4.786	144.000	2,304.11	3.073
70.000	11,888.77	4.770	145.000	2,259.35	3.046
71.000	11,595.68	4.754	146.000	2,215.59	3.020

Actual Temp. (F)	Actual Resistance (Ohms)	Thermistor Voltage (Note 3)	Actual Temp. (F)	Actual Resistance (Ohms)	Thermistor Voltage (Note 3)
72.000	11,310.78	4.738	147.000	2,172.78	2.993
73.000	11,033.81	4.721	148.000	2,130.95	2.966
74.000	10,764.53	4.705	149.000	2,090.03	2.940
75.000	10,502.71	4.688	150.000	2,050.01	2.913
76.000	10,248.11	4.671	151.000	2,010.87	2.887
77.000	10,000.51	4.653	152.000	1,972.58	2.861
78.000	9,759.70	4.636	153.000	1,935.13	2.834
79.000	9,525.47	4.618	154.000	1,898.49	2.808
80.000	9,297.62	4.600	155.000	1,862.65	2.782
81.000	9,075.96	4.581	156.000	1,827.59	2.756
82.000	8,860.29	4.563	157.000	1,793.28	2.730
83.000	8,650.45	4.544	158.000	1,759.71	2.704
84.000	8,446.26	4.525	159.000	1,726.86	2.678
85.000	8,247.54	4.506	160.000	1,694.72	2.652
86.000	8,054.13	4.486	161.000	1,663.26	2.626
87.000	7,865.87	4.467	162.000	1,632.47	2.601
88.000	7,682.62	4.447	163.000	1,602.34	2.575
89.000	7,504.22	4.426	164.000	1,572.85	2.550
90.000	7,330.53	4.406	165.000	1,543.97	2.524
91.000	7,161.41	4.385	166.000	1,515.71	2.499
92.000	6,996.74	4.365	167.000	1,488.04	2.474
93.000	6,836.36	4.344	168.000	1,460.96	2.449
94.000	6,680.17	4.322	169.000	1,434.43	2.424
95.000	6,528.05	4.301	170.000	1,408.47	2.399
96.000	6,379.86	4.279	171.000	1,383.04	2.375
97.000	6,235.50	4.257	172.000	1,358.14	2.350
98.000	6,094.87	4.235	173.000	1,333.75	2.326
99.000	5,957.84	4.213	174.000	1,309.87	2.302
100.000	5,824.32	4.191	175.000	1,286.48	2.278
101.000	5,694.22	4.168	176.000	1,263.57	2.254
102.000	5,567.42	4.145	177.000	1,241.13	2.230
103.000	5,443.84	4.122	178.000	1,219.15	2.206
104.000	5,323.39	4.099	179.000	1,197.61	2.183
105.000	5,205.97	4.075	180.000	1,176.52	2.159
106.000	5,091.51	4.052			

Notes:

1. Discharge sensor 4RT8 is connected between Terminals 1TB4-13 and -14 on micro module 1U3; overall accuracy is as follows:

± 2 F from 100 F to 180 F; and,
± 5 F from 32 F to 100 F.

2. Optional bearing temperature sensors are connected between Terminals 1TB4-19 and -20 (4RTB), and 1TB4-21 and -22 (4RTB); sensor accuracy is ± 2 F.

3. As you compare a thermistor resistance (or input voltage) reading with the "actual" temperature indicated by the thermometer, be sure to consider the precision of the thermometer when you decide whether or not the thermistor is out of range.

Table 12
Sensor Conversion Data:
Winding Temperature (4B1R2, 4B1R3, 4B1R4)

Actual Temp. (F)	Sensor Voltage (Volts)	Nominal Resistance (Ohms)	Acceptable Resistance Values (Ohms)	
			Minimum	Maximum
50	0.321 ± 0.05	70.1 ± 2.7	67.4	72.8
55	0.326 ± 0.05	71.1 ± 2.7	68.4	73.8
60	0.330 ± 0.05	72.1 ± 2.7	69.4	74.8
65	0.334 ± 0.05	73.1 ± 2.7	70.4	75.8
70	0.338 ± 0.05	74.0 ± 2.6	71.4	76.6
75	0.342 ± 0.05	75.0 ± 2.6	72.4	77.6
80	0.347 ± 0.05	76.0 ± 2.6	73.4	78.6
85	0.351 ± 0.05	77.0 ± 2.6	74.4	79.6
90	0.355 ± 0.05	78.0 ± 2.6	75.4	80.6
95	0.359 ± 0.05	79.0 ± 2.6	76.4	81.6
100	0.364 ± 0.05	80.0 ± 2.6	77.4	82.6
110	0.372 ± 0.05	82.0 ± 2.5	79.5	84.5
120	0.381 ± 0.05	84.0 ± 2.5	81.5	86.5
130	0.390 ± 0.05	86.0 ± 2.5	83.5	88.5
140	0.397 ± 0.05	88.0 ± 2.5	85.5	90.5
150	0.407 ± 0.05	90.2 ± 2.4	87.8	92.6
160	0.415 ± 0.05	92.2 ± 2.4	89.8	94.6
170	0.424 ± 0.05	94.3 ± 2.3	92.0	96.6
180	0.433 ± 0.05	96.5 ± 2.3	94.2	98.8
190	0.441 ± 0.05	98.5 ± 2.3	96.2	100.8
200	0.450 ± 0.05	100.8 ± 2.3	98.5	103.1
210	0.459 ± 0.05	103.0 ± 2.2	100.8	105.2
220	0.468 ± 0.05	105.1 ± 2.2	102.9	107.3
230	0.476 ± 0.05	107.2 ± 2.1	105.1	109.3
240	0.486 ± 0.05	109.5 ± 2.0	107.5	111.5
250	0.494 ± 0.05	111.6 ± 2.0	109.6	113.6
260	0.504 ± 0.05	114.0 ± 2.0	112.0	116.0
270	0.514 ± 0.05	116.4 ± 2.1	114.3	118.5
280	0.523 ± 0.05	118.7 ± 2.2	116.5	120.9
290	0.532 ± 0.05	121.1 ± 2.2	118.9	123.3
300	0.542 ± 0.05	123.6 ± 2.3	121.3	125.9
310	0.552 ± 0.05	126.1 ± 2.3	123.8	128.4

Notes:

1. Sensor 4B1R2 is connected between Terminals 1TB4-15 and -17 on micro module 1U3; sensor 4B1R3 is connected between Terminals 1TB4-16 and -17, and sensor 4B1R4 is connected between Terminals 1TB4-18 and -17. Overall accuracy of these sensors is ± 15 F.

2. As you compare a thermistor resistance (or input voltage) reading with the "actual" temperature indicated by the thermometer, be sure to consider the precision of the thermometer when you decide whether or not the thermistor is out of range.

For those sensors with readings displayed at the front panel (i.e., entering and leaving evaporator water temperatures, entering and leaving condenser water temperatures, and evaporator refrigerant temperature), check the displayed temperature plus 0.5 F against the measured temperature. If the sensor checks out okay but the module reads in error, 1U3 must be replaced.

Note: In all instances where module replacement is indicated, perform these tests before module change out:

a. Check the power supply according to the information in Power Supply Checkout Procedure.

b. Repeat the checkout procedure using a new sensor.

Troubleshooting With Control Panel Diagnostics

b A3 Evaporator Refrigerant Temperature Range

Diagnostic b A3 appears on the control panel display when the setpoint determined by the "evaporator refrigerant trip" potentiometer is below the minimum allowable setting. A minimum setpoint of 29 F is permitted for standard range units; this value drops to 0 F for extended range unit applications.

To check the evaporator trip setpoint:

1. Turn the evaporator refrigerant "trip" setpoint potentiometer fully clockwise.
2. Adjust the chiller switch to "Standby/Reset". (If the chiller switch is already at "Standby/Reset", flip it to one of the "Auto" positions, then back to "Standby/Reset". This should clear the diagnostic and display operating code AO.)
3. Turn the slide valve control to "Hold".
4. Press the display advance push button until the evaporator trip setpoint code prefix I appears on the display. Latching diagnostic b A3 occurs if the setpoint is out-of-range low.
5. With the chiller switch still in "Standby/Reset" and the slide valve control knob at "Hold", readjust the evaporator refrigerant trip setpoint by turning the potentiometer screw until the desired setpoint is reached.

If the display does not change when this adjustment is made, interrupt control panel power for a minute or so; then restore power and repeat Step 4. If the display still does not respond, the micro module (1U3) may be defective. Use the Power Supply Checkout Procedure to determine whether the module must be replaced.

b A4, A7, A8 Motor Temperature Sensors

Any one of these diagnostics i.e., b A4, b A7 or b A8) is displayed, and the unit shut down, when the temperature measured at the corresponding sensor input (Table 13) is above $265 \pm F$. To determine whether the sensor is open or malfunctioning, or if micro module 1U3 is defective, follow the checkout procedure outlined in "Temperature Sensor Checkout".

Table 13
Motor Temperature Sensors

Sensor Designation	Electrical Designation	Electrical Connections (1U3)	Diagnostic Code*
Sensor #1	4B1R2	1TB4-15, -17	b A4
Sensor #2	4B1R3	1TB4-16, -17	b A7
Sensor #3	4B1R4	1TB4-18, -17	b A8

*These diagnostics occur only when the unit is not running—or when the chiller is reset.

b Ab Leaving (Evaporator) Water Temperature Sensor

Latching diagnostic b Ab occurs whenever the temperature measured by the leaving evaporator water temperature sensor (4RT1) drops below 15 F. (A leaving water temperature "low limit" stops chiller operation at 35.3 F on standard range units only.)

Use the instructions in "Temperature Sensor Checkout" to determine whether sensor 4RT1 is open or malfunctioning. (The sensor leads are connected to terminals 1TB3-1 and 1TB3-2 on micro module 1U3.)

If the results of the sensor checkout indicate that 4RT1 is functioning properly, determine why the leaving water temperature is so low; among the possible causes to consider are:

Chilled water flow problems (e.g., plugged strainers or heat exchangers, bypassed water, pump malfunction, or erratic return water temperature).

b Ad Evaporator Refrigerant Temperature Sensor

The evaporator refrigerant temperature sensor (4RT5) is factory-installed in a bulbwell located below the unit control panel, near the bottom of the evaporator shell. A latching diagnostic condition, b Ad, is initiated if 4RT5 senses an evaporator refrigerant temperature below -5 F or above 150 F.

Should this occur, use the sensor checkout procedure in "Temperature Sensor Checkout" to determine whether 4RT5 is open/shorted or malfunctioning. (4RT5 is connected to terminals 1TB3-12 and 1TB3-13 on micro module 1U3.)

Note: The b Ad sensor diagnostic normally occurs only during a nonoperating mode, since the evaporator trip setpoint is much higher than -5 F. No normal machine operating conditions will yield an evaporator refrigerant temperature lower than -5 F.

b AE Ambient Temperature Sensor (Optional)

Latching diagnostic b AE occurs when the optional ambient temperature sensor (4RT6) registers an outdoor air temperature exceeding 150 F. If b AE appears on the display, determine whether or not 4RT6 is shorted or malfunctioning. (Follow the sensor checkout procedure in Temperature Sensor Checkout section.)

The optional ambient temperature sensor is connected between micro module (1U3) terminals 1TB3-14 and 1TB3-15.

b d9 Extended Power Loss

Occurrence of this nonlatching "power-up" diagnostic indicates that the UCM detected a power loss lasting more than 30 line-cycles. Once power is restored, the b d9 diagnostic is retained in the "Last Diagnostic Code" register, and the UCM automatically indicates a "power-on" reset. See "b E2: Momentary Power Loss" for further information.

b dc Condenser Water Flow Overdue

During the start sequence, the UCM closes condenser water pump relay K6 (i.e., located between terminals 1TB1-4 and 1TB1-5 on relay output module 1U1). Closure of the K6 contacts issues a signal to start the condenser water pump. As the UCM checks for condenser water flow, the operating code appearing on the display changes from A 70 (restart inhibit) to A 71 (establish condenser water flow).

If flow is not proven (i.e., condenser water flow switch 5S3 does not close) within 3 minutes of K6 contact closure, the unit will shut down on latching diagnostic b dc.

A number of component malfunctions and operating problems can result in a "condenser water flow overdue" diagnostic; below is a partial list.

1. Faulty condenser water pump relay (K6).
2. Faulty condenser water pump contactor (5K2).
3. Faulty condenser water pump auxiliary contactor (5K2).
4. Faulty condenser water flow switch (5S3).
5. Faulty condenser water pump relay (1K17).
6. Closed condenser water circuit valves.
7. Condenser water circuit valves are open to too many machines.
8. Plugged condenser water circuit strainers.

Before restarting the chiller, determine why condenser water flow was not established and correct the problem.

Note: To troubleshoot the condenser water pump electrical circuit (i.e., Items 1 through 5 above), refer to checkout procedure for condenser water pump relay.

b E2 Momentary Power Loss

Occurrence of this nonlatching diagnostic indicates that there was a brief loss of power. Keep in mind that the power interruption must last at least 2 or 3 line-cycles in order for the micro module to detect it; 1U3 will then take the chiller off-line within 6 line-cycles (i.e., including detection time). Momentary power losses of this type are usually caused by an automatic switching gear in the main power lines.

A power loss lasting from 1 to 30 line-cycles results in a normal unit shutdown. The UCM undergoes a "power-on" reset and follows the normal start-up criteria. Diagnostic b E2 is then stored in the "Last Diagnostic Code" entry of the display menu.

If the power interruption lasts more than 30 line-cycles, the UCM identifies this as an "extended power loss" and initiates a "power-on" reset after power is restored. The b d9 diagnostic is retained in the "Last Diagnostic Code" register, and the unit follows the normal start-up criteria (e.g., restart inhibit, differential-to-start, etc.) (See b d9: Extended Power Loss.)

Note: The UCM identifies a "momentary power loss" condition when the incoming current is below 15% of the rated load amps (RLA) and the "main run" starter contactor (2K1) is closed.

b E3 Phase Imbalance (Optional)

Latching diagnostic b E3 occurs when a phase imbalance exceeding 15% occurs. The UCM recognizes that a phase imbalance condition exists when the following criteria are met:

- [] The chiller is operating in one of the "run" modes (see Table 1);
- [] The imbalance exists for longer than 1 second; and,
- [] the percent of imbalance is greater than 15%.

Note: The percent of imbalance is calculated using this equation—

$$\frac{I_{Ph\#} - I_{Avg}}{I_{Avg}} \times 100$$

where $I_{Ph\#}$ is one of the 3 phases, and $I_{Avg} = \frac{I_{Ph1} + I_{Ph2} + I_{Ph3}}{3}$

3

Two possible (but not the only) causes of a phase imbalance are: (1) a voltage imbalance of the incoming power, and (2) a resistance imbalance of the compressor motor windings. (The latter is very rare because of the stringent specifications employed by the motor manufacturer during the winding and testing of new motors.)

To determine whether the fault lies with the line power or the motor, follow the procedures outlined below.

WARNING: To prevent injury or death due to electrical shock, use extreme care when working with energized electrical equipment.

Note: Amperage measured must be line current (not phase current), and should be measured at the line side of the starter (i.e., incoming power lines). Measure voltage at the motor terminals while the unit is operating; any voltage imbalance related to the starter or to wiring resistance will be included in the imbalance calculations.

1. Voltage imbalance can be caused by a voltage drop across any of the starter panel components:

a. Measure voltage across each of the starter components to the motor terminals on each phase while the unit is operating.

b. Use the low (i.e., 0 to 5 volts) scale of a volt-ohmmeter to read the voltage on either side of the same electrical phase on all contactors, fuses, circuit breakers, leads, etc. There should not be any appreciable voltage drop across any of these circuits.

If a measured voltage drop is observed across a lead or contactor, a poor connection or worn contact is indicated. Repair or replace as necessary.

c. If the results of Steps 1a and 1b indicate that the voltage imbalance is not caused by the starter or motor leads, contact the power company.

2. If there is a current imbalance with no measurable voltage imbalance, determine whether a motor or line problem exists. To do this, rotate the line leads twice since the RTHA compressor is not designed to run backwards.

If the current imbalance follows one set of phase leads, the incoming power is at fault and may be the result of unbalanced impedance or resistance somewhere in the power system. Contact the power company for assistance.

If the current imbalance remains with a particular motor winding, contact the Pueblo Technical Service Department with complete nameplate information.

Note: To override the phase imbalance feature, move DIP switch no. 7 on DIP switch block S3 to the ON position.

b E4 Phase Loss

Occurrence of this latching diagnostic indicates that 1 leg of the 3-phase power supply has been lost. The phase loss "threshold" recognized by the UCM is any phase that drops below 15% of the RLA for more than 1 second.

A variety of causes can result in a phase loss condition; three of these include: (1) a blown fuse or breaker in one leg; (2) an incomplete or open line connector to one leg; and (3) a burned or open motor winding. Be sure to determine and correct the fault condition that created the phase loss before restarting the unit.

b E5 Phase Reversal

(Unit should not be started until phase rotation has been determined to be clockwise). Latching diagnostic b E5 is generated by the UCM within 1 second of its detection of a counterclockwise phase rotation in the incoming power. (For proper machine operation, the incoming power must be phased or clockwise rotation.)

Note: It is essential to check proper phase rotation prior to start-up.

Possible reasons for a phase reversal condition include, but are not limited to, these:

1. Incoming power is phased or counterclockwise rotation;
2. Current transformer polarity (i.e., primary or secondary) is reversed;
3. A current transformer wiring error; and,
4. An electrical connection error between the current transformer and micro module 1U3.

If phase rotation is incorrect, the unit will shut down on the b E5 diagnostic when a start-up is attempted. To reverse the rotation, change the phasing at the incoming power to the starter. Do not attempt to change rotation at the motor terminals!

WARNING: To prevent injury or death due to electrical shock, open chiller disconnect switch before reversing phasing.

If you determine that the incoming power is phased correctly, conduct a thorough checkout of the current transformer polarity and wiring. (Some additional information on current transformer checkout is provided in this service guide, i.e., "Checkout Procedure for Compressor Transition Relay".)

b E7 High Motor Temperature

Three RTD-type sensors embedded in the motor windings enable the UCM to monitor the temperature of the compressor motor. If the UCM detects a motor winding temperature exceeding 265 F (i.e., +/- 15 F, UCM error only), it initiates a latching diagnostic. Code b E7 flashes on the control panel display and the unit is shut down.

Below is a list of some of the circumstances that can result in a "high motor temperature" diagnostic:

1. Inaccurate sensor response or open sensor (i.e., check the sensors and micro module 1U3 using the instructions in the sensor conversation data.
2. "Low voltage" condition, resulting in over-ampage.
3. Motor operation in excess of the RLA.
4. Short cycling of motor (insufficient time between when motor sees LRA).

b F2 Proving Oil Flow

Sufficient oil flow through the bearing oil supply system must be confirmed within 30 seconds after start-up by closing flow switch 4S5, or the unit locks out on low oil flow. (Latching diagnostic b F2 will flash alternately with operating code A 74 on the display.) If latching diagnostic b F2 appears, check oil filter and service valves.

b E8 Oil Flow Switch Closed

If 4S5 oil flow switch is closed before start-up, b E8 diagnostic is displayed. This checks for an oil flow switch that is not functioning properly. Check for flashing between b E8/A 72. Check for defective 4S5.

b E9 Stop Relay

This latching diagnostic is generated if you attempt to shut down the chiller, but the UCM continues to detect current; when this situation occurs, the UCM takes the chiller off-line by opening the overload relay.

b EC Running Overload

Latching diagnostic b EC is generated by the UCM when the average 3-phase current drawn by the compressor motor exceeds 107% of the RLA. The "time-to-trip" interval graduates from 20 seconds to 107% RLA to 1 second at 140% RLA. Chiller control near the compressor RLA is comprised of a 5-step "corrective action" control sequence designed to minimize the likelihood of overload lockouts caused by normal operating fluctuations in amperage. The 5 steps in this corrective action sequence are:

1. Slide valve loading limited
2. Slide valve loading prevented
3. Modulated slide valve unloading
4. Hard slide valve unload
5. Chiller shut down on latching diagnostic b EC

b Ed Chilled Water Flow

Code b Ed represents a nonlatching diagnostic condition caused when the chilled water flow interlock circuit opens. A built-in time delay of 2 seconds (i.e., maximum without flow) is designed to eliminate nuisance tripouts caused by a fluttering flow switch.

Because this diagnostic is nonlatching, the chiller automatically attempts to restart when the interlock circuit closes. The b Ed code is then stored in the "Last Diagnostic Code" register of the display menu. Manual (i.e., from a remote source) start-up of the chilled water pump(s) is required.

Use the steps outlined below to determine why the chilled water flow diagnostic occurred:

1. Verify that the chilled water pump is turned on.
 - a. If the pump is not running, check for blown fuses, open disconnect switches, etc.
 - b. If the pump is running, check for plugged strainers. Also, ensure that pump capacity is sufficient to handle all of the chillers piped into the chilled water circuit.
2. Check the status of chilled water flow switch 5S2; if it is open, see Step 1b. In addition, be sure that the proper pressure drop is provided to the unit. If the flow rate is correct, flow switch 5S2 may be defective.
3. Check the status of the chilled water pump contactor auxiliary (5K1); it should be closed whenever the pump is running.
4. Verify that chilled water pump relay 1K16 (i.e., located in the unit control panel;) is energized and that its contacts are closed. Relay 1K16's contacts are connected between terminals 1TB3-20 and 1TB3-21 on micro module 1U3.
5. Determine whether micro module 1U3 is functioning correctly. To do this, install a jumper between terminals 1TB3-20 and 1TB3-21, and set the chiller switch at one of the "Auto" positions.

If the b Ed diagnostic code is cleared from this display, 1U3 is operating properly. However, if b Ed remains on the display, micro module 1U3 is defective and must be replaced.

Caution: To ensure proper chiller protection, never start the unit when the chilled water flow interlock circuit is jumpered! If jumper installation clears the diagnostic, remove the jumper immediately. If the diagnostic does not clear within 3 minutes, remove the jumper and replace 1U3.

b F0 Transition

Latching diagnostic b F0 occurs when the starter fails to complete transition. Micro module 1U3 monitors the status of a normally-open set of auxiliary contacts on the "run" contactor (2K2). (Relay 2K2 is located in the starter panel.) If these contacts do not close within 2.8 seconds +/- 10% after the transition signal is sent to the starter, the UCM shuts down unit operation on the b F0 diagnostic.

Notice that the auxiliary on contactor 2K2 is tied to terminals 2TB3-7 and 2TB3-8 in the starter panel and, from there, to terminals 1TB4-5 and 1TB4-6 on micro module 1U3 in the unit control panel. See Figures 3 through 6.

Among the possible reasons for a failure to transition are these:

Faulty wiring or bad connections in the proof-of-transition circuit.

Note: Be sure to verify that the normally-open 2K2 auxiliary contacts located between terminals 2TB3-7 and -8 close to provide a "transition complete" signal to micro module 1U3. If a voltage signal is present at terminals 1TB4-5 and -6 but 1U3 fails to recognize it, 1U3 is defective and must be replaced.

WARNING: Use extreme care when performing this checkout procedure with power on; carelessness can result in injury or death due to electrical shock.

Defective "run" contactor auxiliary (2K2).

Check for closure of the 2K2 auxiliary contacts when the main contactor closes. This circuit is monitored by a 12 VDC, 45 mA current. 2K2 auxiliary contacts connected to these terminals must be compatible with current described above: gold-plated contacts are recommended to avoid oxidation resistance.

Defective compressor transition relay (K5; located on power supply output module 1U2 in the unit control panel).

Note: Micro module 1U3 will not generate a b F0 diagnostic unless it sees the conditions necessary for transition and initiates the transition signal.

Monitor the status of the K5 relay contacts at terminals 1TB2-5 and 1TB2-6 on power supply output module 1U2. If the K5 contacts do not close, follow the transition relay troubleshooting instructions provided in Compressor Transition Relay Checkout Section. (This will isolate the malfunction at either 1U2 or 1U3.)

If the K5 contacts do close, the problem lies either in the starter or in the wiring connections to the starter. Use the "Electrical Sequence of Operation" in the unit Operation/Maintenance manual and the wiring diagrams provided with the starter as a guide for determining proper starter operation.

b F1 Running External Interlock

The UCM generates latching diagnostic condition b F1 when the field-supplied and field-installed run spare fault switch (5S4) closes during chiller operation. This switch input becomes active 1 second after transition, but is ignored by micro module 1U3 before and during start-up.

In the event that a b F1 diagnostic occurs, check the electrical connections made at terminals 1TB4-3 and 1TB4-4. Verify that these terminals are not jumpered, and that the device connected to them, if any, is functioning properly.

If the external circuit appears to be okay, remove the wires from 1TB4-3 and 1TB4-4 and operate the chiller. Disappearance of the b F1 diagnostic indicates that the problem is somewhere in the external circuit, while its reoccurrence implies that micro module 1U3 is defective and must be replaced.

Power Supply Checkout Procedure

Overview

Refer to Figure 7. Notice that the UCP control panel contains a power supply transformer (1T1) and a power supply output module (1U2) that furnish power to micro module 1U3. The information in this section describes a method for verifying that both of these components (i.e., 1T1 and 1U2) are operating properly. For your reference, a typical control panel connection diagram and electrical schematic for a standard RTHA unit (with unit-mounted starter and remote mounted starter) are illustrated in Figures 3 through 6.

Note: It is good practice to check the power supply components (i.e., 1T1 and 1U2) whenever troubleshooting the micro module. An improper voltage input to 1U3 can cause a good micro module to produce erratic output responses.

Power Supply Output Module 1U2 Checkout (Figure 8)

Refer to Figure 7 when performing the following steps for a power supply output module checkout.

1. Remove the cover strip located along the top of micro module 1U3, and find ribbon cable connector 1P4. See Figure 7. Verify that ribbon cable 1P4 is firmly and correctly connected to 1J4.

Note: Notice that, in this instance, the pins are numbered from left to right.

2. Using a digital VOM set to register DC voltage signals, connect the black (negative) VOM lead to Pin 1P4-14 (Figure 8).

3. Measure the voltages at Pins 1P4-10, -11, -12, -13, -16, -18, -19 and -20. Compare these voltage readings with the allowable voltage signal indicated in Figure 8.

4. Set the VOM to register AC voltage signals; then connect the black VOM lead to Pin 1P4-11 and the red VOM lead to Pin 1P4-10. Measure the voltage between these pins, and compare this value to the "AC component" range shown for Pins 10 and 11 in Figure 8.

Note: If any of the voltages measured in Steps 3 and 4 are out of range, and the power transformer checked out okay, a problem with the power supply output module is indicated.

Figure 7
UCP Layout

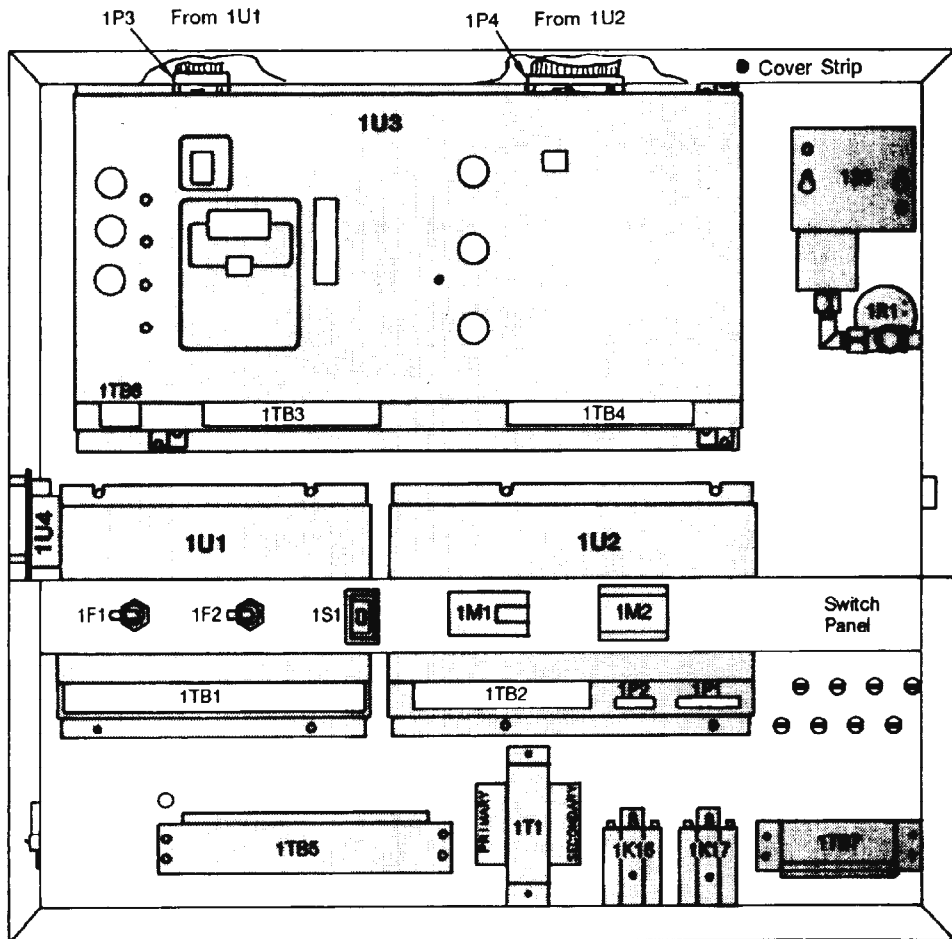

Legend

1F1 = Control Circuit Fuse	1T1 = Power Supply Transformer	6U5 = Ice Maker Optional
1F2 = 1T1 Primary Fuse	1TB1 = 1U1 Terminal Block	6U6 = Ice Maker Latch Panel
1K16 = Chilled Water Flow Switch Relay	1TB2 = 1U2 Terminal Block	
1K17 = Condenser Water Flow Switch Relay	1TB3 = 1U3 Terminal Block	
1M1 = Hour Meter	1TB4 = 1U3 Terminal Block	
1M2 = Start Counter	1TB5 = Control Voltage Terminal Block	
1R1 = Condenser Pressure Transducer	1TB6 = 1U3 Terminal Block	
1P1 = 1U2 Power Supply Plug	1TB7 = Control Voltage Terminal Block	
1P2 = 1U2 Power Supply Plug	1U1 = Relay Output Module	
1S1 = Unit Service Switch	1U2 = Power Supply Output Module	
1S3 = High Pressure Cutout	1U3 = Micro Module	
	1U4 = Chilled Water Reset Interface Module	

5708-0825D

Figure 8
Checkout Schematic for output module 1U2
Ribbon Cable 1P4 Identification and Voltages

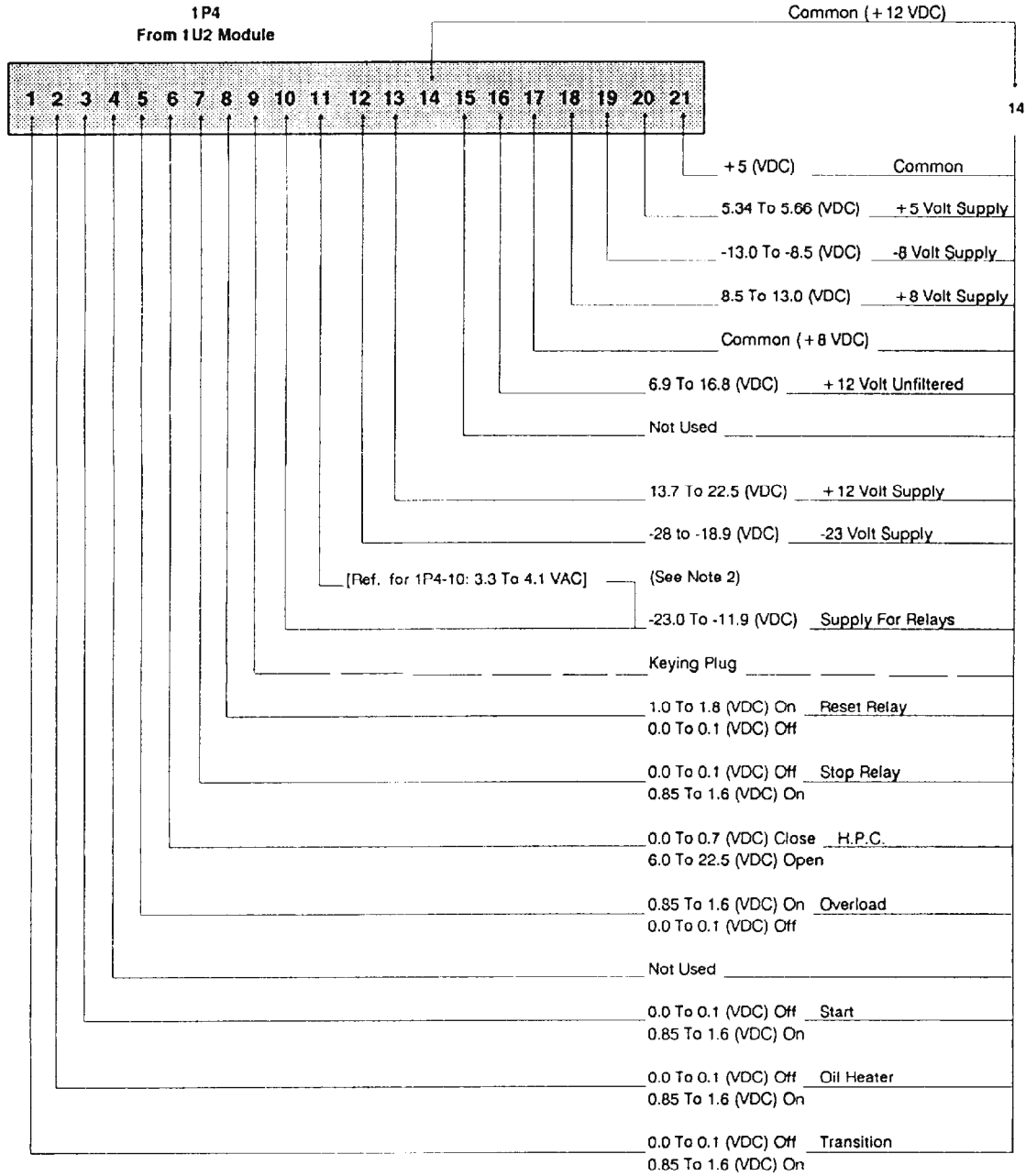

Notes:

1. Voltage values in this table apply only when ribbon connector 1P4 is connected to 1J4 of micro module 1U3. All voltage signal values shown are with respect to Terminal 1P4-14 unless otherwise indicated.
2. Reference 1P4-11 To 1P4-14 (-23.0 To -11.9 VDC).

Power Transformer (1T1) Checkout (Figure 9)

1. Check branch circuit fuse 1F2 for continuity.
2. Confirm that 120 VAC power is available across the 2 black leads of transformer 1T1.
3. Verify that the output cable (1P1) from power supply transformer 1T1 is firmly and correctly attached to 1J1 on power supply output module 1U2.

Before proceeding to Steps 4, 5 and 6, keep these points in mind when taking the requested measurements: (1) the pins on 1P1 are numbered from right to left; and (2) be sure that good contact is made with the metal of the pin.

4. Connect the black (negative) lead of a digital VOM-set to measure DC voltage to pin 1P1-1 (i.e., chassis common). Then, measure the voltages at Pins 1P1-2 thru -10, and compare the measured values with the allowable signal ranges shown in Figure 9.

Note: If any of the voltages measured in Step 4 are out of range, and the voltages measured in Steps 5 and 6 are in range, transformer 1T1 is okay but power supply output module 1U2 may be malfunctioning. Check 1U2's output before replacing either component.

5. Switch the digital VOM to register AC voltages, and, with the black VOM lead still connected to PIN 1P1-1, measure the voltages at Pins 1P1-2, -3, -4, -6 and -8. Compare these measured voltages with the allowable signal ranges indicated in Figure 9.

6. Move the black (negative) lead of the VOM to Pin 1P1-7; then measure the voltages at Pins 1P1-8 and -10. Compare the voltage readings obtained with the allowable signal ranges indicated in Figure 9.

Note: If any of the voltages measured in Steps 5 and 6 are out of range, a problem with power supply transformer 1T1 is indicated. Before replacing 1T1, use the blade of a small screwdriver to press the wires of 1J1 firmly into their sockets. Occasionally, the wire insulation is not cut completely when the wires were initially inserted into the connector.

Figure 9
Power Supply Transformer (1T1) Checkout.
Ribbon Cable Plug 1P1 Identification and Voltages.

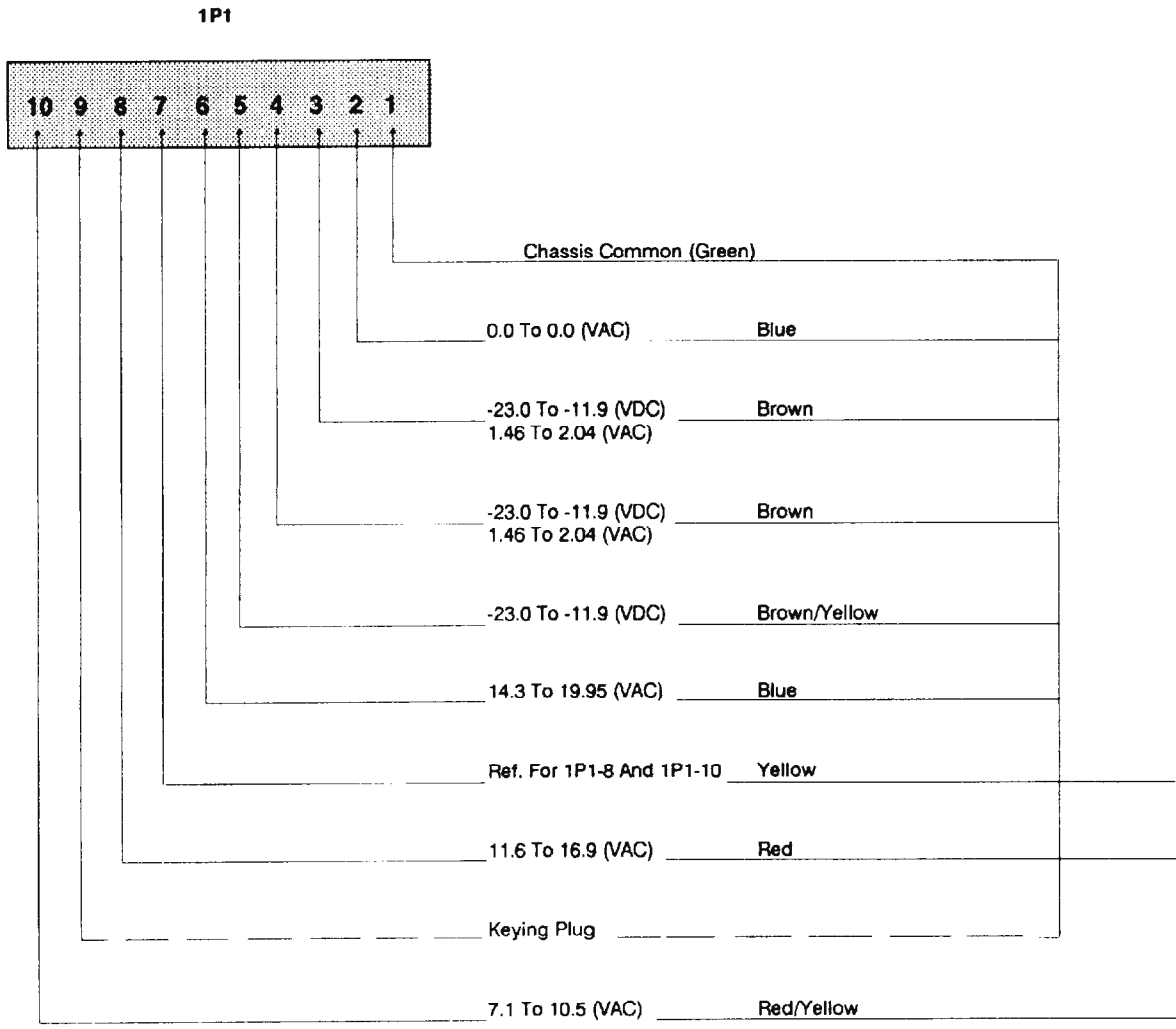

Notes:
 VAC are measured with respect to 1P1-7
 VDC are measured with respect to 1P1-1

Compressor Transition Relay 1U2K5 and Current Transformer Checkout Procedures

To effectively use the compressor transition relay (1U2K5) and current transformer (2T1, 2T2, 2T3, 2T5, 2T6 and 2T7) checkout procedures described in this section, it is important to first understand the normal operation of the control panel during start-up. Review the start sequence (along with the typical electrical schematic in Figures 3 thru 6 before attempting to check the integrity of 1U2K5.

1. Micro module 1U3 initiates a "start" signal.

Once all of the prestart criteria are satisfied (i.e., condenser and chilled water flows proven, etc.), micro module 1U3 initiates a "start" signal by "telling" the K1, K2, K3 and K4 relay contacts in power supply output module 1U2 to close.

Proper response to all 4 sets of contacts allows control voltage to flow from Terminal 1TB2-9 to 1TB2-7; from there, current passes to Terminal 1TB5-10 (and 2TB2-6) where it energizes the coil to pilot relay 2K5 in the starter panel.

2. "Start" windings of chiller compressor motor 4B1 energize.

Once energized, pilot relay 2K5 begins the compressor motor start process by energizing the coil of shorting contactor 2K3; this, in turn, energizes start contactor 2K1. Closure of 2K1's normally-open contacts allows line voltage to flow through the "start" windings of the compressor motor (4B1).

3. Micro module 1U3 initiates transition.

Milliampere signal inputs at Terminals 1TB4-7 through -12 allow micro module 1U3 to monitor compressor motor amperage draw via 3 pairs of current transformers.

Keep in mind that 1U3's control logic prevents it from initiating transition unless these two conditions are met:

- a. First, motor amp draw must exceed 15% of the rated load amps (RLA); and,
- b. 2.8 seconds must elapse after initiation of start signal.

If both of these requirements are satisfied, 1U3 initiates transition by energizing the compressor transition relay (1U2K5) in the power supply output module.

Note: 1U2K5 is energized when the voltage signal at Pin 1 (with respect to Pin 14) on ribbon connector 1P4 is 0.85 to 1.6 VDC. (See Figure 8).

4. Transition occurs successfully, and compressor motor 4B1 is operating in the normal run configuration.

Closure of the K5 compressor transition relay contacts in 1U2 allows current to reach the coil of the starter panel's transition contactor (2K4). As 2K4 energizes, its normally-closed auxiliary contacts open to de-energize shorting contactor 2K3.

Run contactor 2K2 energizes when 2K3's normally-closed auxiliary contacts re-close (Notice that the 2K4 transition contactor de-energizes as soon as the normally-open 2K2 auxiliary contacts in the transition circuit.)

When line voltage flows across the now-closed 2K2 contacts to the "delta" windings of 4B1, the compressor motor is in its normal "run" configuration.

5. Micro module 1U3 confirms that transition was successfully completed.

Notice that a normally-open set of auxiliary contacts on run contactor 2K2 is located in a "proof-of-transition" circuit connected to micro module input Terminals 1TB4-5 and -6.

Closure of these auxiliary 2K2 contacts "tells" micro module 1U3 that transition occurred successfully.

If these contacts do not close within 2 seconds after the transition signal is sent to the starter (see Step 3), micro module 1U3 assumes that the compressor motor failed to transition, and shuts down unit operation on latching diagnostic b F0.

Faulty current-sensing inputs (1TB4-7 thru -12)

Recall that in Step 3 of the preceding start sequence, 1U3 monitors the milliamperage signals it receives at input Terminals 1TB4-7 through -12 to determine whether or not compressor motor amp draw exceeds 15% or RLA. Control logic prevents 1U3 from initiating the transition signal unless this prerequisite is met.

Faulty current-sensing inputs may prevent 1U3 from "seeing" this amp draw (i.e., causing it to shut down unit operation on b E4 phase loss or b E2 momentary power loss).

Defective micro module (1U3)

Latching diagnostic b F0 can occur if micro module 1U3 receives the appropriate current-sensing inputs at Terminals 1TB4-7 through -12, but fails to issue a "close" signal to the normally-open 1U2K5 contacts because of an internal malfunction.

(Review Step 3 of the start sequence again. Notice that the existence of a 0.85 to 1.6 VDC voltage signal at Pin 1P4-1, with respect to Pin 1P4-14, confirms that 1U3 did tell the 1U2K5 contacts to close.)

Defective power supply output module (1U2)

Even though motor amp draw requirements are satisfied and 1U3 successfully transmits a "transition" signal to the power supply output module (1U2), transition will not occur if 1U2 is defective and fails to close its K5 compressor transition relay contacts.

Faulty starter component(s) or wiring

Refer again to Step 4 of the start sequence. Notice that closure of the 1U2K5 contacts should provide current to transition contactor 2K4 (and, ultimately, run contactor 2K2) in the starter panel. If the electrical connections between 1U3 and the starter panel are faulty, or if either 2K4, 2K3 or 2K2 is defective, transition will not occur, and 1U3 will generate a b F0 or b E2 ("momentary power loss") diagnostic.

Faulty "proof-of-transition" circuit

Keep in mind that the existence of a b F0 diagnostic may not necessarily mean that the starter failed to transition. It is equally possible that transition was completed successfully, but micro module 1U3 is not receiving "proof of transition" at input Terminals 1TB4-5 and -6. In this situation, either the auxiliary 2K2 contacts are malfunctioning, or the "transition complete" electrical circuit is defective.

Note: The 2K2 auxiliary contacts are rated for a dry circuit. Ensure that contacts are rated as such.

Whenever a b F0 (or, in some cases a b E4 or b E2) chiller diagnostic condition exists, use the following checkout procedure to isolate the source of the transition-related failure.

Note: The micro module checks for a faulty (shorted) transition contact before entering start sequence (b F0 diagnostic). The micro module allows 2 seconds to receive a confirmation of transition complete after transition is initiated.

1U2K5 Checkout Procedure

Note: The steps in this procedure were purposely arranged for ease of completion, and do not reflect the sequence of events previously described for a normal, attempted start-up.

WARNING: Use extreme care when performing this checkout procedure while the chiller is energized. Carelessness can result in injury or death.

1. Connect the voltmeter to Terminals 1TB2-5 and -6, and check for closure of the K5 contacts during the chiller start sequence.

If the K5 contacts do not close, go to Step 2 and complete the step-by-step instructions that follow to isolate the malfunction at power supply output module 1U2, micro module 1U3, or the current transformers (i.e., 2T1, 2T2, 2T3, 2T5, 2T6 and 2T7).

Note: If the K5 compressor transition relay contacts do close during the start sequence, the problem lies either in: (1) the starter itself, or (2) the wiring connections to the starter.

2. Set a digital VOM to register DC voltage; then connect the black (negative) VOM lead to Pin 1P4-14 and the red lead to Pin 1P4-1.

3. Repeat the chiller start sequence and check the VDC signal at Pin 1P4-1 when at most 2.8 seconds have elapsed since initiation of start signal.

If the signal measured at Pin 1P4-1 does not increase from 0.0-0.1 VDC to 0.85-1.6 VDC when the 2.8 seconds have elapsed, replace micro module 1U3.

Note: If input voltage at Pin 1P4-1 does increase to 0.85-1.6 VDC, but the 1U2K5 contacts do not close, power supply output module 1U2 may be defective. Perform the power supply checkout procedure described in this service guide. (An improper voltage input to 1U2 can cause a good micro module to produce erratic output responses.)

Current Transformer Checkout

Each phase of the incoming power supply to the compressor motor is provided with line (2T1, 2T2, 2T3) and auxiliary (2T5, 2T6, 2T7) current transformers. All of these CTs are mounted in the starter panel; current transformer connections are shown in Figure 10.

Note: Polarity is critical for proper setup of both line and auxiliary current transformers. Be sure to check each CT for proper polarity, and all CT wiring for faulty connections, before performing the checkout procedure described below. Use Table 14 to verify that correct line CT's are in use and check that proper terminals are connected using Figure 10.

WARNING: Use extreme care when performing this checkout procedure while the chiller is energized. Carelessness can result in injury or death.

1. Use the unit's design RLA value in conjunction with the data in Factory Set-up to verify that:

a. The primary current transformers (CTs: 2T1, 2T2 and 2T3) are properly sized.

b. Each primary CT is provided with the correct number of "primary turns" (i.e., number of times that the main power line passes through its CT); and,

c. The DIP switches used to establish the unit's RLA setpoint (i.e., DIP switch block S1, switch numbers 1 through 8) are properly positioned. (A step-by-step RLA-setpoint verification procedure is provided in this service guide.)

2. Use a series ammeter to monitor the output of Phase 1's line current transformer (2T1).

Figure 10
Current Transformer (CT)
Connections

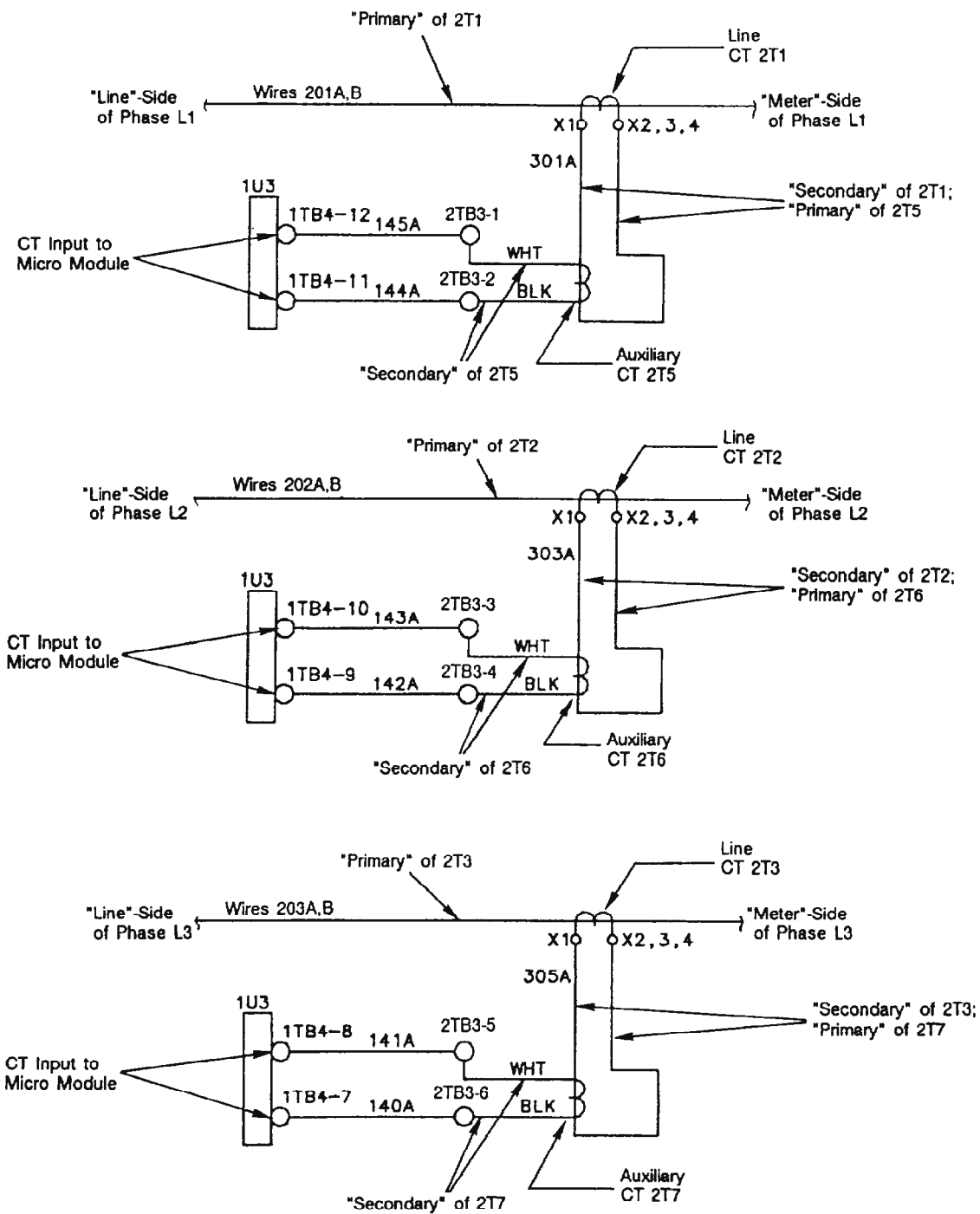

Note: This check cannot be made reliably with a clamp-on ammeter; always use a series ammeter on the CT secondary! In order to check the CT input and output voltages, CT line and secondary amp flows must be monitored while the unit is running.

3. Check the voltage at Terminals 1TB4-11 and -12 on micro module 1U3, and compare this value to the corresponding auxiliary CT primary amperage value shown in Table 14 to verify the integrity of 2T5.

4. Repeat Steps 1 through 3 for Phase 2 and Phase 3.

5. Check the integrity of auxiliary CT 2T6 and 2T7 as described in Step 3 by measuring the voltage at Terminals 1TB4-9 and -10, and Terminals 1TB4-7 and -8, respectively.

Table 14
Current Transformer Inputs to
Micro Module 1U3 (1)

Primary Current (I1) to Auxiliary CTs 2T5, 2T6 and 2T7	Input Voltage at: 1TB4-11, -12; 1TB4-9, -10; and 1TB4-7, -8, Respectively (See Note 3)
0.50 amps RMS	1.34 ± 0.05 volts RMS
1.00 amps RMS	1.83 ± 0.05 volts RMS
1.25 amps RMS	2.06 ± 0.05 volts RMS
1.50 amps RMS	2.28 ± 0.05 volts RMS
1.75 amps RMS	2.51 ± 0.05 volts RMS
2.00 amps RMS	2.73 ± 0.05 volts RMS
2.25 amps RMS	2.95 ± 0.05 volts RMS
2.50 amps RMS	3.17 ± 0.05 volts RMS
2.75 amps RMS	3.39 ± 0.05 volts RMS
3.00 amps RMS	3.62 ± 0.05 volts RMS
3.25 amps RMS	3.84 ± 0.05 volts RMS
3.50 amps RMS	4.06 ± 0.05 volts RMS
3.75 amps RMS	4.28 ± 0.05 volts RMS
4.00 amps RMS	4.51 ± 0.05 volts RMS
4.25 amps RMS	4.71 ± 0.05 volts RMS
4.50 amps RMS	4.93 ± 0.05 volts RMS
4.75 amps RMS	5.14 ± 0.05 volts RMS
5.00 amps RMS	5.37 ± 0.05 volts RMS
5.50 amps RMS	5.80 ± 0.05 volts RMS
6.00 amps RMS	6.24 ± 0.05 volts RMS
8.00 amps RMS	7.96 ± 0.05 volts RMS

Notes:

1. To calculate primary current (I1), use the following equation:

$$(I1) = \frac{\text{Line Current} \times 5}{\text{CTRA}}$$

where: (I1) is the primary current to the auxiliary current transformer (CT); the "CTRA" value is for 2T1, 2T2 and 2T3, respectively (see Table 2); and "Line Current" is the primary current thru the line CTs (2T1, 2T2 and 2T3).

To calculate % RLA, measure line current directly; then use the following equation:

$$\% \text{ RLA} = \frac{\text{Line Current}}{100\% \text{ of Unit RLA Rating}} \times 100\%$$

2. Accuracy of the line CT is ± 1%.
3. Excludes meter error.
4. RMS - root mean square (i.e., standard AC meter units).

Checkout Procedure For Slide Valve Operation

Slide Valve Control Switch

A 4-position, compressor slide valve control switch is located beneath the current limit setpoint control. Each switch position is described below.

Note: For 130 to 215 ton unload solenoid is on motor side of compressor.
For 255 to 300 ton unload solenoid is on discharge side of compressor.

Pressure Gauge

Connect a pressure gauge at the Schrader valve by the Load/Unload solenoids.

Load

With the switch in LOAD position, the slide valve load relay (1U1Q7) is continuously energized, manually loading the compressor. Manual load overrides automatic slide valve control during Normal Run mode (A 74). Verify that the pressure reading of the gauge approaches condensing pressure. If pressure remains the same or falls to evaporator pressure, check wiring at solenoid valve coils.

Manual load will not override automatic slide valve control during three other running modes. They are:

<u>Operating Code</u>	<u>Operating Mode</u>
A 75	Run - Current Limit
A 76	Run - Condenser Limit
A 77	Run - Evaporator Limit

Hold

With the slide valve control switch in HOLD position, both slide valve load relay (1U1Q7) and slide valve unload relay (1U1Q8) are de-energized (closed). The slide valve remains in present position. HOLD overrides automatic slide valve control during Normal Run mode (A74). Read pressure gauge and verify that pressure remains constant and does not fluctuate. HOLD will not override automatic slide valve control during three other running modes. They are:

<u>Operating Code</u>	<u>Operating Mode</u>
A 75	Run - Current Limit
A 76	Run - Condenser Limit
A 77	Run - Evaporator Limit

Note: Turning the slide valve control switch to HOLD changes UCM display from Operators menu to Serviceman's Menu. (See "Display" and Table 3.)

Unload

With slide valve control switch to UNLOAD position, slide valve unload relay (1U1Q8) is continuously energized. Manual unload overrides all other operating modes. Read pressure gauge and verify that pressure reading approaches evaporator pressure. If remains the same or rises to condenser pressure, check wiring and solenoid.

Auto

With slide valve control switch in AUTO (normal operating position), slide valve position is automatically controlled by the UCM. Gauge pressure will be somewhere between condenser and evaporator pressure.

Condenser Water Pump Relay Checkout

Relay Operation

Operation of the condenser water pump is controlled by a set of normally-open contacts (K6) on the control panel's relay output module (1U1). When operating code A 71 (i.e., establish condenser water flow) appears on the control panel display, micro module 1U3 "directs" 1U1 to close its K6 contacts, and these contacts should remain closed until unit operation is terminated.

Once these contacts close, continuity is established between terminals 1TB1-4 and 1TB1-5; this energizes the remotely-mounted condenser water pump contactor (5K2) which, in turn, energizes the condenser water pump.

When the condenser water pump is energized, micro module 1U3 monitors the contacts of condenser water pump interlock relay 1K17. If these contacts do not close (i.e., flow is not established) within 3 minutes of the K6 contact closure, the chiller will shut down on latching diagnostic b dC (i.e., condenser water flow overdue).

Note: This diagnostic code will flash alternately with operating code A 71 on the display.

Relay Troubleshooting

WARNING: To prevent injury or death due to electrical shock, use care when measurements, adjustments or other service-related operations are performed with power on.

Note: Micro module 1U3 must be "calling" for condenser pump operation while using the following procedure to check the condenser water pump control circuit. To "prompt" this signal, either:

- a. Manually start the condenser pump; then start the unit (i.e., the K6 contacts should be closed when the unit is operating); or,
- b. Go through a normal start sequence. When the display reads A71, the K6 contacts should be closed. (Remember that the K6 contacts will only remain closed for 3 minutes if the condenser interlock circuit does not "make").

If condenser water flow is not established within 3 minutes:

1. Measure the DC voltage at pins 3 and 11 on ribbon connector 1P3 (Figure 11) at micro module 1U3. Remember that A 71 must be on the display!

If the voltage reading is 0.0 to 0.1 VDC, 1U3 is failing to send a "close" signal to the K6 contacts on 1U1. Replace micro module 1U3.

Note: Always check the power supply output module before replacing micro module 1U3.

A voltage reading of 0.85 to 1.6 VDC indicates that 1U3 is functioning normally (i.e., is sending a "close" signal to the (1U1) K6). Check for closure of the K6 contacts (Step 2).

Figure 11
Checkout Schematic for Output Module (1U1),
Ribbon Cable Plug 1P3 Pin Identification
and Voltages

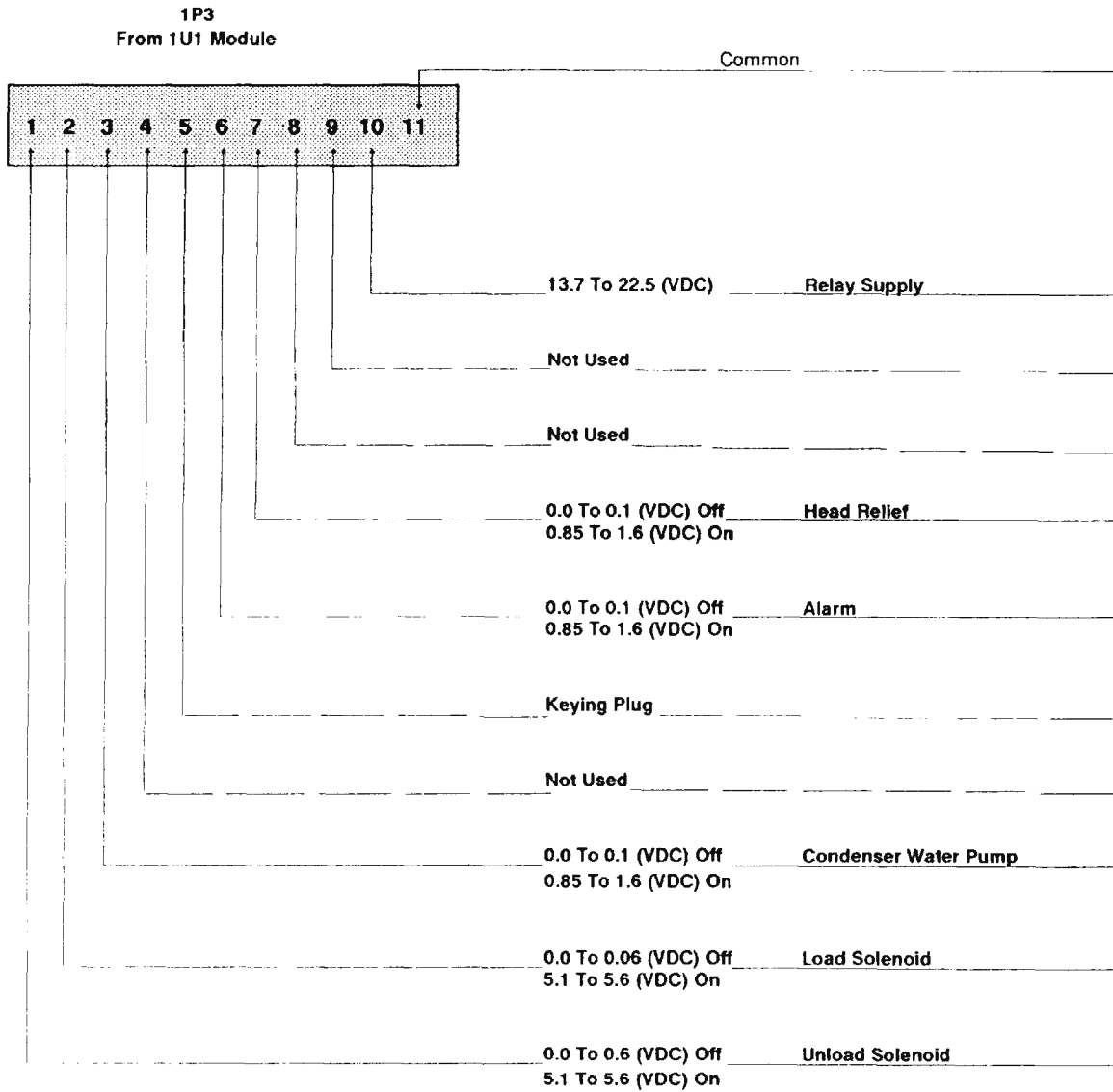

Note:
 All voltages are D.C. with respect to 1P3-11

2. Check for continuity between terminals 1TB1-4 and 1TB1-5 on 1U1 to determine if the normally-open K6 contacts are closed.

If the K6 contacts are still open, relay output module 1U1 is defective and must be replaced.

Note: Always check the power supply output module before replacing relay output module 1U2.

Closure of the K6 contacts indicates that the problem is outside of the UCP control panel; see Step 3.

3. Below is a partial list of the control components to check if the K6 contacts are closed:

Check for blown fuses or open circuit breakers in the condenser water pump circuit.

Verify that the condenser water pump contactor (5K2) is energized, and that its contacts are starting the pump.

Ensure that the valves in the condenser water circuit are open to allow flow through the chiller.

Verify that the condenser water flow switch (5S3) is functioning properly.

Check the auxiliary contacts on the condenser water pump contactor (5K2); they should close when the pump starts.

4. If the external portion of the condenser pump circuit is functioning properly a 110-volt signal should return to the control panel at terminal 1TB7-6. Verify that this circuit is energizing condenser water pump relay 1K17. Next, determine whether or not relay 1K17 is providing a "closed circuit" input to terminals 1TB3-22 and 1TB3-23 on micro module 1U3.

If the 1K17 contacts do not close between terminals 1TB3-22 and -23 when there is a 110-volt signal at 1TB7-6, the condenser water pump relay (1K17) is defective and must be replaced.

Unit shutdown on diagnostic b dC (i.e., condenser water flow overdue) in spite of closure of the 1K17 contacts within 3 minutes indicates that micro module 1U3 is malfunctioning and must be replaced.