

WARNING
HAZARDOUS VOLTAGE!
DISCONNECT ALL ELECTRIC POWER INCLUDING REMOTE DISCONNECTS AND FOLLOW LOCK OUT AND TAG PROCEDURES BEFORE SERVICING. INSURE THAT ALL MOTOR CAPACITORS HAVE DISCHARGED STORED VOLTAGE. UNITS WITH VARIABLE SPEED DRIVE, REFER TO DRIVE INSTRUCTIONS FOR CAPACITOR DISCHARGE. FAILURE TO DO THE ABOVE COULD RESULT IN DEATH OR SERIOUS INJURY.

AVERTISSEMENT
TENSION DANGEREUSE!
COUPER TOUTES LES TENSIONS ET OUVRIR LES SECTIONNEURS A DISTANCE, PUIS SUIVRE LES PROCEDURES DE VERROUILLAGE ET DES ETIQUETTES AVANT TOUTE INTERVENTION. VERIFIER QUE TOUTS LES CONDENSATEURS DES MOTEURS SONT DECHARGES. DANS LE CAS D'UNITES COMPORTANT DES ENTRAÎNEMENTS A VITESSE VARIABLE, SE REPORTER AUX INSTRUCTIONS DE L'ENTRAÎNEMENT POUR DECHARGER LES CONDENSATEURS. UN MANQUEMENT A LA PROCEDURE CI-DESSUS PEUT ENTRAÎNER DES BLESSURES GRAVES, VOIRE LA MORT.

ADVERTENCIA
VOLTAJE PELIGROSO!
DESCONECTE TODA LA ENERGIA ELÉCTRICA, INCLUSO LAS DESCONEXIONES REMOTAS Y SIGA LOS PROCEDIMIENTOS DE CIERRE Y ETIQUETADO ANTES DE PROCEDER AL SERVICIO. ASEGÚRESE DE QUE TODOS LOS CAPACITORES DEL MOTOR HAYAN DESCARGADO EL VOLTAJE ALMACENADO. PARA LAS UNIDADES CON TRANSMISIÓN DE VELOCIDAD VARIABLE, CONSULTE LAS INSTRUCCIONES PARA LA DESCARGA DEL CONDENSADOR. NO REALIZAR LO ANTEDICHO PUEDE PROVOCAR LA MUERTE O LESIONES GRAVES.

NOTICE
USE COPPER CONDUCTORS ONLY!
UNIT TERMINALS ARE NOT DESIGNED TO ACCEPT OTHER TYPES OF CONDUCTORS. FAILURE TO DO THE ABOVE COULD RESULT IN EQUIPMENT DAMAGE.

AVIS
N'UTILISER QUE DES CONDUCTEURS EN CUIVRE!
LES BORNES DE L'UNITÉ NE SONT PAS CONÇUES POUR RECEVOIR D'AUTRES TYPES DE CONDUCTEURS. UN MANQUEMENT A LA PROCEDURE CI-DESSUS PEUT ENTRAÎNER DES DOMMAGES A L'EQUIPEMENT.

AVISO
UTILICE ÚNICAMENTE CONDUCTORES DE COBRE!
LAS TERMINALES DE LA UNIDAD NO ESTÁN DISEÑADAS PARA ACEPTAR OTROS TIPOS DE CONDUCTORES. NO REALIZAR LO ANTEDICHO PUEDE PROVOCAR DAÑOS EN EL EQUIPO.

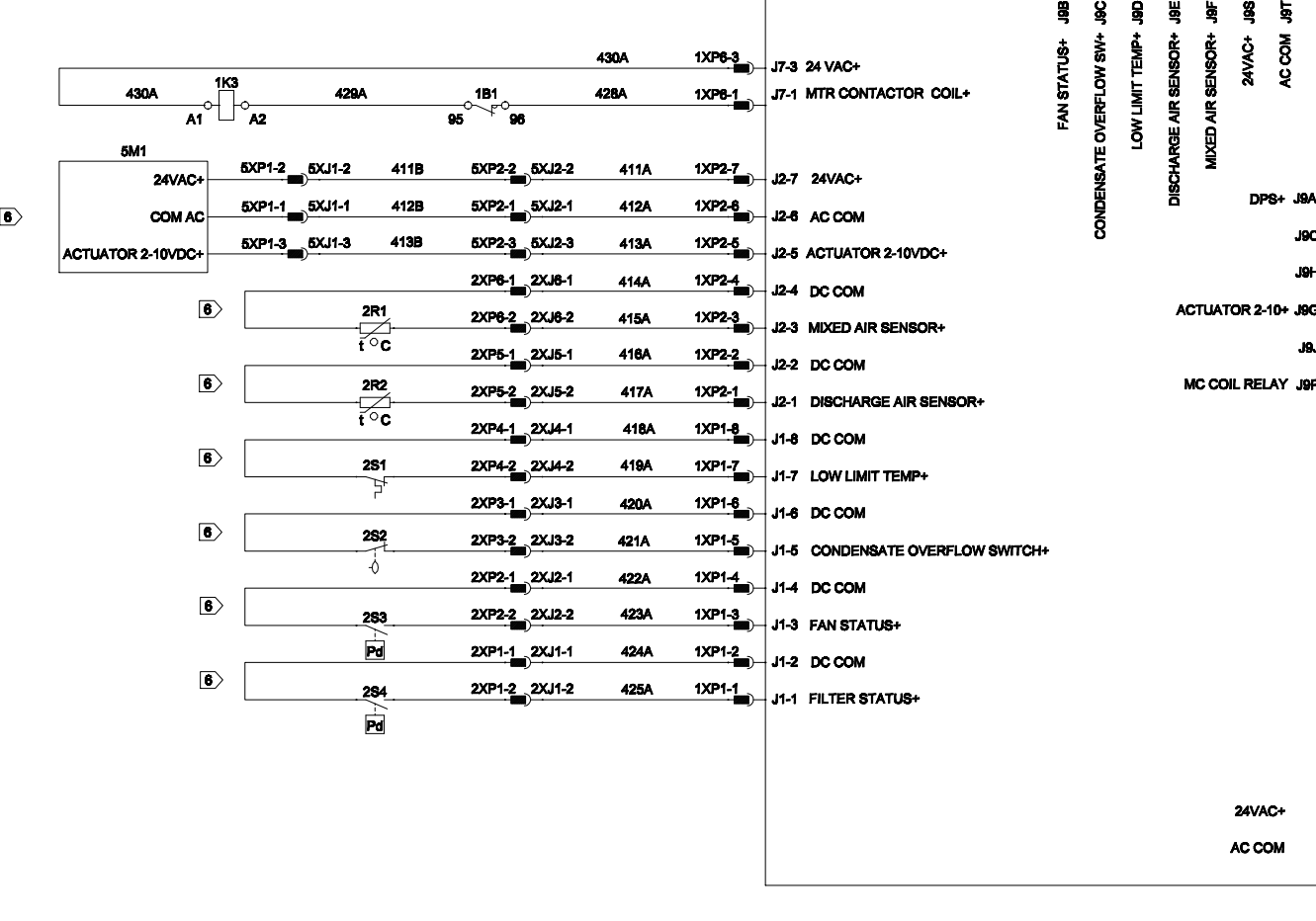
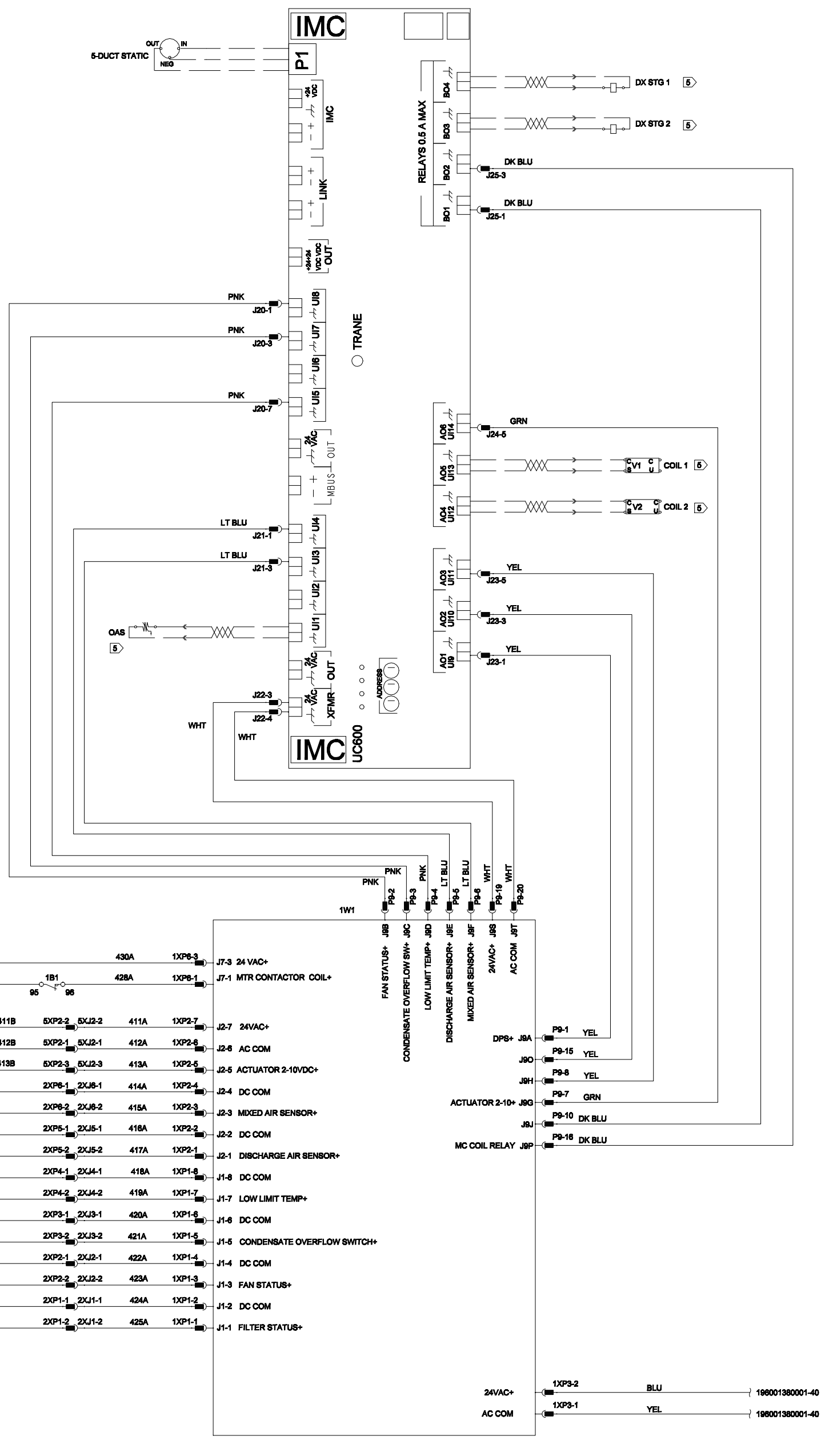

- NOTES:
- UNLESS OTHERWISE NOTED ALL SWITCHES ARE SHOWN AT 25 ° C (77 ° F), AT ATMOSPHERIC PRESSURE, AT 50% RELATIVE HUMIDITY, WITH ALL UTILITIES TURNED OFF, AND AFTER A NORMAL SHUTDOWN HAS OCCURRED.
 - DASHED LINES INDICATE RECOMMENDED FIELD WIRING BY OTHERS. DASHED LINE ENCLOSURES AND/OR DASHED DEVICE OUTLINES INDICATE COMPONENTS PROVIDED BY THE FIELD. PHANTOM LINE ENCLOSURES INDICATE ALTERNATE CIRCUITRY OR AVAILABLE SALES OPTIONS. SOLID LINES INDICATE WIRING BY TRANE.
 - NUMBERS ALONG THE RIGHT SIDE OF THE SCHEMATIC DESIGNATE THE LOCATION OF CONTACTS BY LINE NUMBER. AN UNDERLINED NUMBER INDICATES A NORMALLY CLOSED CONTACT. AN OPEN ARROWHEAD BELOW THE LINE NUMBER POINTING UPWARD INDICATES A TIMED CONTACT WHICH BEGINS TIMING WHEN ENERGIZED.
 - ALL FIELD WIRING MUST BE IN ACCORDANCE WITH THE NATIONAL ELECTRICAL CODE, STATE, AND LOCAL REQUIREMENTS. OTHER COUNTRIES APPLICABLE NATIONAL AND/OR LOCAL REQUIREMENTS SHALL APPLY. FIELD CONDUCTORS SHALL HAVE INSULATION RATING NOT LESS THAN 600V COPPER CONDUCTORS ONLY.

- 5 CONNECTIONS ARE INTENDED FOR CLASS 2 ONLY.
- 6 ALL AVAILABLE END DEVICES SHOWN. SEE UNIT CONFIGURATION FOR END DEVICES ON UNIT.

AREA	LOCATION
1	MAIN CONTROL PANEL
2	SUPPLY FAN & COIL SECTION
3	ELECTRIC HEAT CONTROL BOX
4	FILTER SECTION
5	MIXING BOX SECTION
6	COIL ACCESS SECTION
7	EXTERNAL PIPING
8	FIELD INSTALLED DEVICE
9	VFD CONTROL PANEL

DEVICE	DESCRIPTION	ZONE
1B1	RELAY, OVERLOAD	46
1K3	MOTOR CONTACTOR	46
1W1	ADAPTER BOARD UC600	66
2R1	MIXED AIR SENSOR	51
2R2	DISCHARGE AIR SENSOR	53
2S1	LOW LIMIT SWITCH	55
2S2	CONDENSATE OVERFLOW SWITCH	57
2S3	FAN STATUS SWITCH	59
2S4	FILTER STATUS SWITCH	61
5M1	DAMPER ACTUATOR	47

DRAWN BY: P. LOCHER
 © TRANE DATE: 03 JUL 2014
 MASTER FILE:
 REVISION DATE:
 REPLACES:
 SIMILAR TO:
 USED BY:

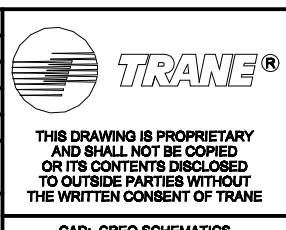

SCHEMATIC
 LOW VOLTAGE
 SINGLE MOTOR, NO VFD, NO ELECTRIC HEAT
 UC600
 208V, 230V, 480V, 575V

196001410008 SHEET
 REV A