

SIEMENS

I-T-E® Molded Case Circuit Breakers

FD-Frame
Information and
Instruction Guide



⚠ DANGER



Hazardous voltages are present inside the enclosures or panels in which the circuit breakers are installed. Electrocution, serious injury, and/or equipment damage will result if circuit breakers are improperly applied or precaution is not used.

De-energize all incoming power prior to installation of circuit breakers or associated accessories.

Only qualified personnel should work on or around this equipment.

Position of circuit breaker handles shown in this booklet is for illustration purposes only. Circuit breakers are to be installed in OFF or TRIPPED position only.

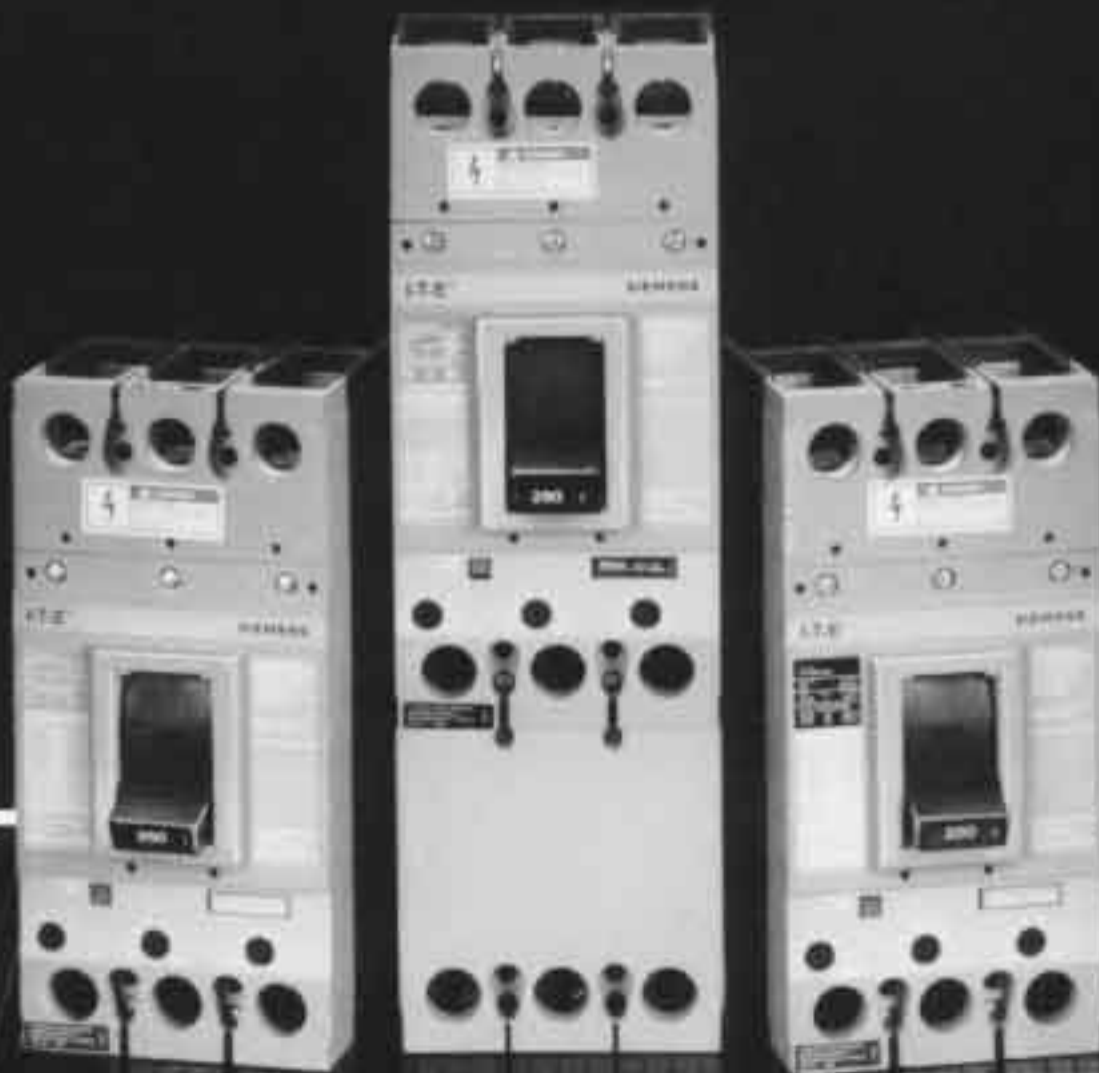

I-T-E® FD-Frame Circuit Breakers 2 and 3-Pole; 70-250 Amperes

Types FXD6A, FD6A, HFD6, HFXD6, HHFD6, HHFXD6, CFD6,
FXD6-ETI, CFD6-ETI

Table of Contents

Important Notices	2	Accessories (Cont'd):	
General Information	3, 4	Rotary Handle Operators (D11CFU1, D11CFU2)	24, 25
Dimensional Reference Drawings	5, 6	Rotary Handle Operators (CRHOFSD, CRHOFVD)	26, 27
Trip Unit Assembly	7	Rotary Handle Operator (F6RH1)	28, 29
Pressure Wire Connectors	8	Rotary Handle Operator (F6RHV9)	30-32
Compression Connector	9	Max-Flex™ Flange-Mount Handle Operator	33-37
Handle Blocking Device	10	Door Latch Mechanism	38, 39
Padlocking Device	10	TELEMAND® Electric Motor Operator	40-42
Rear Connecting Studs	11	Connecting Straps	43
Plug-In Adapters	12, 13	Enclosures	44, 45
Walking Beam Interlock, Panel and Plug-In Mounted Circuit Breakers	14,17	Operating Characteristics:	
Accessories:		Time Current Curves	46, 47
Shunt Trip, Undervoltage Trip, Auxiliary Switch and Bell Alarm Switch Installation	18-21	Let-Thru Curves	48, 49
Accessory Combinations	21	Ordering Information:	
Shunt Trip and Undervoltage Trip Electrical Check	22	Circuit Breaker Catalog Numbers	50-53
Auxiliary Switch and Bell Alarm Switch Electrical Check	23	Circuit Breaker Accessories Catalog Numbers	53-54
		Miscellaneous:	
		UL Listings and File Numbers	54
		Industry Specifications	54

Important

This equipment contains hazardous voltages. Death, serious personal injury or property damage can result if safety instructions are not followed. Only qualified personnel should work on or around this equipment after becoming thoroughly familiar with all warnings, safety notices and maintenance procedures contained herein. The successful and safe operation of this equipment is dependent upon proper handling, installation, operation and maintenance.

Qualified Person

For the purpose of this manual and product labels, a qualified person is one who is familiar with the installation, construction and operation of the equipment, and the hazards involved. In addition, he or she has the following qualifications:

- (a) Is trained and authorized to energize, de-energize, clear, ground and tag circuits and equipment in accordance with established safety practices.
- (b) Is trained in the proper care and use of protective equipment such as rubber gloves, hard hat, safety glasses or face shields, flash clothing, etc., in accordance with established safety practices.
- (c) Is trained in rendering first aid.

Definitions

Danger

For the purpose of this manual and product labels, **Danger** indicates an imminently hazardous situation which, if not avoided, will result in death or serious injury.

Warning

For the purpose of this manual and product labels, **Warning** indicates a potentially hazardous situation which, if not avoided, could result in death or serious injury.

Caution

For the purpose of this manual and product labels, **Caution** indicates a potentially hazardous situation which, if not avoided, may result in minor or moderate injury.

Information and Instruction Guide

General Information

General

FD-Frame Sentron™ Series circuit breakers, as shown on pages 5 and 6 are for use in individual enclosures, switchboards and panelboards. They are available as thermal magnetic with interchangeable trip unit (types FD6-A, HFD6), thermal magnetic with non-interchangeable trip unit (type FXD6-A), suitable for reverse feed applications, current limiting (type CFD6) instantaneous magnetic only (motor circuit protectors—types FXD6-ETI, CFD6-ETI) and molded case switches (types FXD6, CFD6).

HHFD6 and HHFXD6 type circuit breakers have been designed to extend the interruption capabilities without the use of a second set of contacts as used in the current limiting CFD6 design. HFD6, HFXD6, HHFXD6 and HHFD6 type circuit breakers meet current limiting criteria at 240 and 480 VAC.

CFD6 circuit breakers combine thermal magnetic construction for overload protection and an additional set of “blow-apart” contacts in conjunction with the FD-Frame’s standard “blow-apart” contacts. This arrangement provides for current limiting protection under high fault interrupting conditions as outlined in the National Electric Code, Article 240-11^① and UL 489^② standards. CFD6 circuit breakers are fuseless and therefore require no blown fuses to be located and replace should a high current fault occur. The common trip feature of the circuit breakers is completely retained so that all poles of the circuit breaker are open when caused to trip due to and overload or short circuit.

Pressure wire connectors, suitable for use with aluminum or copper wire, are available for all FD-Frame circuit breakers. Rear connection studs or plug-in connector assemblies are also available (2 and 3-pole). The latter mounting arrangement permits removal of the circuit breaker from a circuit without removing wiring leads. Special features such as a shunt trip, auxiliary and alarm switches and undervoltage trip devices are available for field adaptation. The installation and removal of these devices are mounted internally and Underwriters Laboratories listed, page 54. Information concerning these special devices is found on pages 18-23 and 53.

Thermal Magnetic

FXD6-A, FD6-A, HFD6, HFXD6, HHFD6, HHFXD6, CFD6 type circuit breakers provide complete overload and short circuit protection when applied within their design parameters. Overload and short circuit tripout is accomplished by time-delay thermal trip elements and instantaneous magnetic trip devices. Nominal instantaneous trip values are externally adjustable with eight trip points as shown below.

Breaker Ampere Rating	Nominal Instantaneous Values ^③							
	Low	2	3	4	5	6	7	High
70 - 90	600	640	690	730	770	810	850	900
100 - 110	700	770	840	920	990	1060	1140	1200
125 - 150	800	800	1000	1100	1200	1300	1400	1500
175 - 200	900	1060	1210	1370	1520	1780	1930	2000
225 - 250	1100	1100	1500	1700	1900	2100	2300	2500

^① National Electric Code (240-11)

“A current limiting overcurrent protective device, which when interrupting currents in its current limiting range, will reduce the current flowing in the faulted circuit to a magnitude substantially less than that obtainable in the same circuit, if the device were replaced with a solid conductor having comparable impedance.”

^② Underwriters Laboratories (UL 489, Par. 2.5)

“A circuit breaker that does not employ a fusible element and that when operating within its current limiting range, limits the let-through ¹t to a value less than the ¹t of a 1/2 cycle wave of the symmetrical prospective current.”

^③ All values based on tolerance levels covered by UL 489 standards.

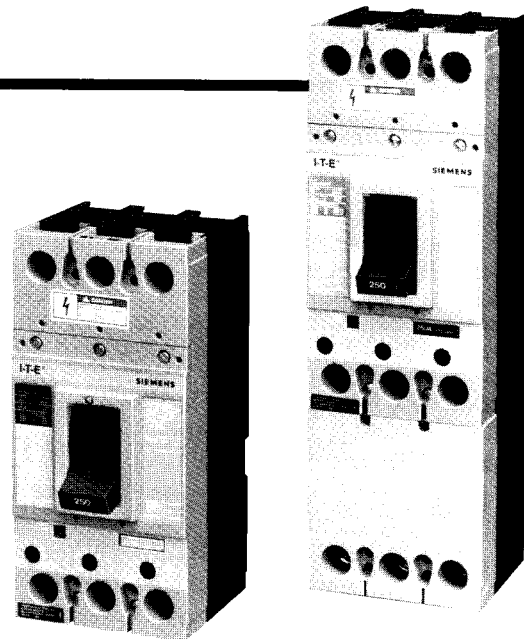

Circuit breakers are calibrated at the factory, under controlled temperature conditions for application at 40°C (104°F) ambient to meet requirements as outlined in UL 489 Standard for molded case circuit breakers. The cover on the trip unit is sealed to prevent access to the trip elements. Alterations of the calibration of these elements should not be attempted. Removal of the special sealed line cover voids the Underwriters Laboratories, Inc. listing for that specific circuit breaker. Catalog information is found on pages 50-52.

Molded Case Switch

A molded case switch is available in the FXD6 and CFD6 type circuit breakers. This device employs the same operating mechanism as the thermal magnetic and magnetic only units. A preset instantaneous function is factory installed to allow the switch to trip and protect itself at a high fault condition. No overload or low fault current protection is provided. This protection must be supplied by separate overcurrent devices. Catalog information is located on pages 50 and 51.

Interrupting Ratings—Symmetrical RMS Amperes (kA) Based on UL 489 Standards, UL File #E10848

Breaker Type	RMS Symmetrical Amperes (kA)				
	UL A.I.R.				
	AC			DC	
	240	480	600	250	500 ^②
FXD6-A, FD6-A	65	35	22	30 (2-P)	18 (3-P)
HFD6, HFXD6	100	65	25	30 (2-P)	25 (3-P)
HHFD6, HHFXD6	200	100	25	—	—
CFD6	200	200	100	30 (2-P)	50 (3-P)

Breaker Type	RMS Symmetrical Amperes (kA)					
	IEC A.I.R. ^①					
	Volts AC (50/60 Hz)					
	220/240		380/415		500	
	(lcu)	(lcs)	(lcs)	(lcs)	(lcu)	(lcs)
FXD6-A, FD6-A	65	33	35	18	20	10
HFD6, HFXD6	100	50	65	33	42	21
HHFD6, HHFXD6	200	100	100	50	65	33
CFD6	—	—	—	—	—	—

^① Meets requirements of IEC 947-2.

^② For 500 V dc application the customer’s power supply and load must be wired as shown in Figure 1 on page 4. Interrupting ratings only apply to breakers used in UPS systems.

Information and Instructions

Operation and Maintenance

Instantaneous Trip

ETI motor circuit interrupters, types FXD6-ETI, CFD6-ETI (adjustable instantaneous magnetic trip only) are designed for use in welding circuits, motor circuits and combination starters where short circuit protection only is required. When used in combination starters, they serve in conjunction with motor protective relays to offer complete protection. The relays guard against motor overloads and the circuit breaker provides short circuit protection. Catalog information is located on page 53.

Instantaneous Trip Adjustments

Motor Full Load Amperes	ETI Trip Setting ^①		Ampere Rating
	Adjustment	Amperes	
30.76- 35.37	Low	400	150 Low
35.38- 39.99	2	460	
40.00- 44.60	3	520	
44.51- 49.23	4	580	
49.23- 53.83	5	640	
53.84- 58.45	6	700	
58.46- 63.06	7	760	
63.07- 74.50	High	820	
61.53- 69.22	Low	800	150 Standard
69.23- 76.91	2	900	
76.92- 84.60	3	1000	
84.61- 92.99	4	1100	
92.30- 99.99	5	1200	
100.00- 108	6	1300	
108- 115	7	1400	
115- 136	High	1500	
85- 100	Low	1100	250 Standard
100- 115	2	1300	
115- 130	3	1500	
131- 146	4	1700	
146- 162	5	1900	
162- 177	6	2100	
177- 192	7	2300	
192- 227	High	2500	

^① All values calibrated within guidelines of UL 489.
 Low setting: -20%, +30%
 High setting: -20%, +30%

Circuit Breaker Operation

With the mechanism latched and the contacts open, the operating handle will be in the OFF position. Moving the handle to the ON position closes the contacts and establishes a circuit through the breaker. Under overload or short circuit conditions sufficient to automatically trip or open the breaker, the operating handle moves to a position between ON and OFF. To relatch the circuit breaker after automatic operation, move the operating handle to the extreme OFF position. The circuit breaker is now ready for reclosing.

The overcenter toggle mechanism is trip free of the operating handle. The circuit breaker, therefore, cannot be held closed by means of the handle should a tripping condition exist. After automatic operation, the handle assumes an intermediate position between ON and OFF, displaying a clear indication of tripping.

Maintenance

Experience has shown that properly applied molded case circuit breakers normally do not require maintenance. However, some industrial users may choose to establish an inspection and maintenance procedure to be carried out on a regular basis. For detailed information, consult applicable NEMA publications or your local Siemens sales office.

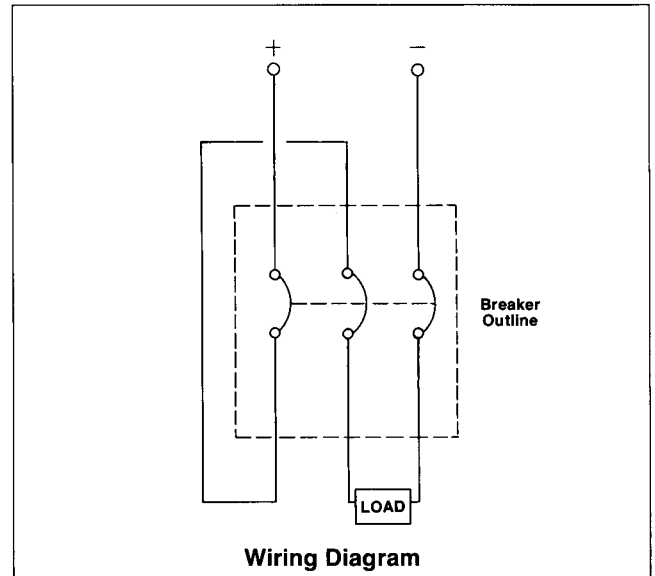

Figure 1

SPECIAL NOTE:

FXD6-A, HFXD6, HHFXD6, AND CFD6 circuit breakers are not UL listed as interchangeable trips—DO NOT REMOVE TRIP UNIT and replace with another. Removal of trip unit voids UL listing.

FXD6-A, HFXD6, and HHFXD6 circuit breakers are also UL listed for reverse feed applications.

Note: Molded case circuit breakers are designed and tested to be applied in accordance to applicable portions of the National Electric code. For example, all molded case thermal magnetic circuit breakers are rated for 80% duty at 40°C unless marked otherwise.

Molded case circuit breakers are to be connected with 60°C or 70°C wire for circuit breakers having a rated ampacity of 125 amperes or less. Circuit breakers having a rated ampacity greater than 125 amperes shall only be cabled with 75°C cable.

Exceptions to this rule are outlined in article 110, section 110-14C (1) and (2) of the National Electric Code.

I-T-E FD-Frame Outline Drawings^① — 2 and 3-Pole^②

Types FXD6, FD6, FXD6A, FD6A, HFD6, HFXD6, HHFD6, HHFXD6, FXD6-ETI

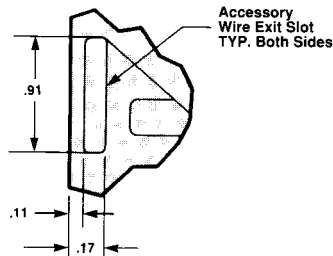
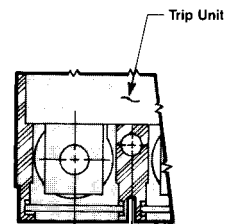
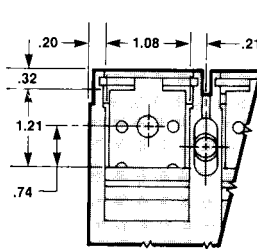
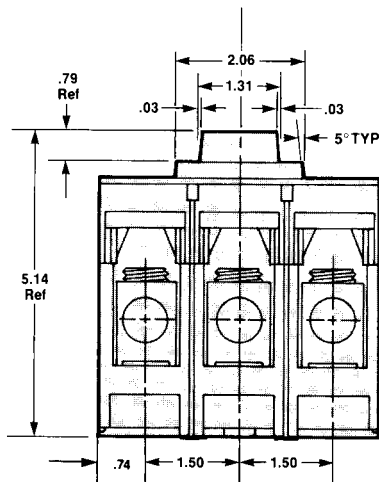
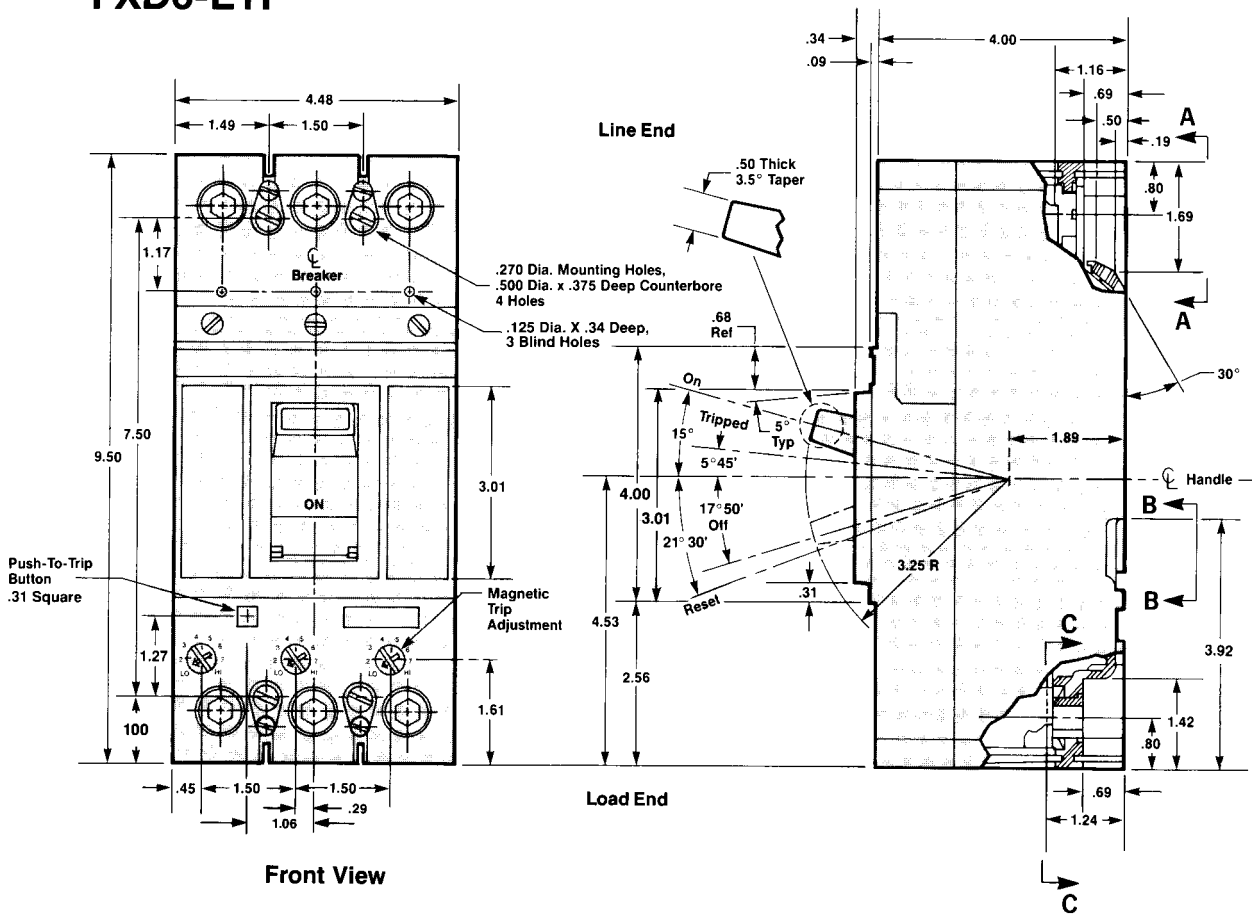

Handle Operating Forces

Operation	Ib.
OFF to ON	18
ON to OFF	20
TRIPPED to RESET	28

- ① All drawing dimensions are shown in inches.
- ② Two and 3-pole breakers are the same physical size. Current carrying parts are omitted from the center pole in 2-pole breakers.

I-T-E FD-Frame Outline Drawings^①—2 and 3-Pole^②

Types CFD6, CFD6-ETI

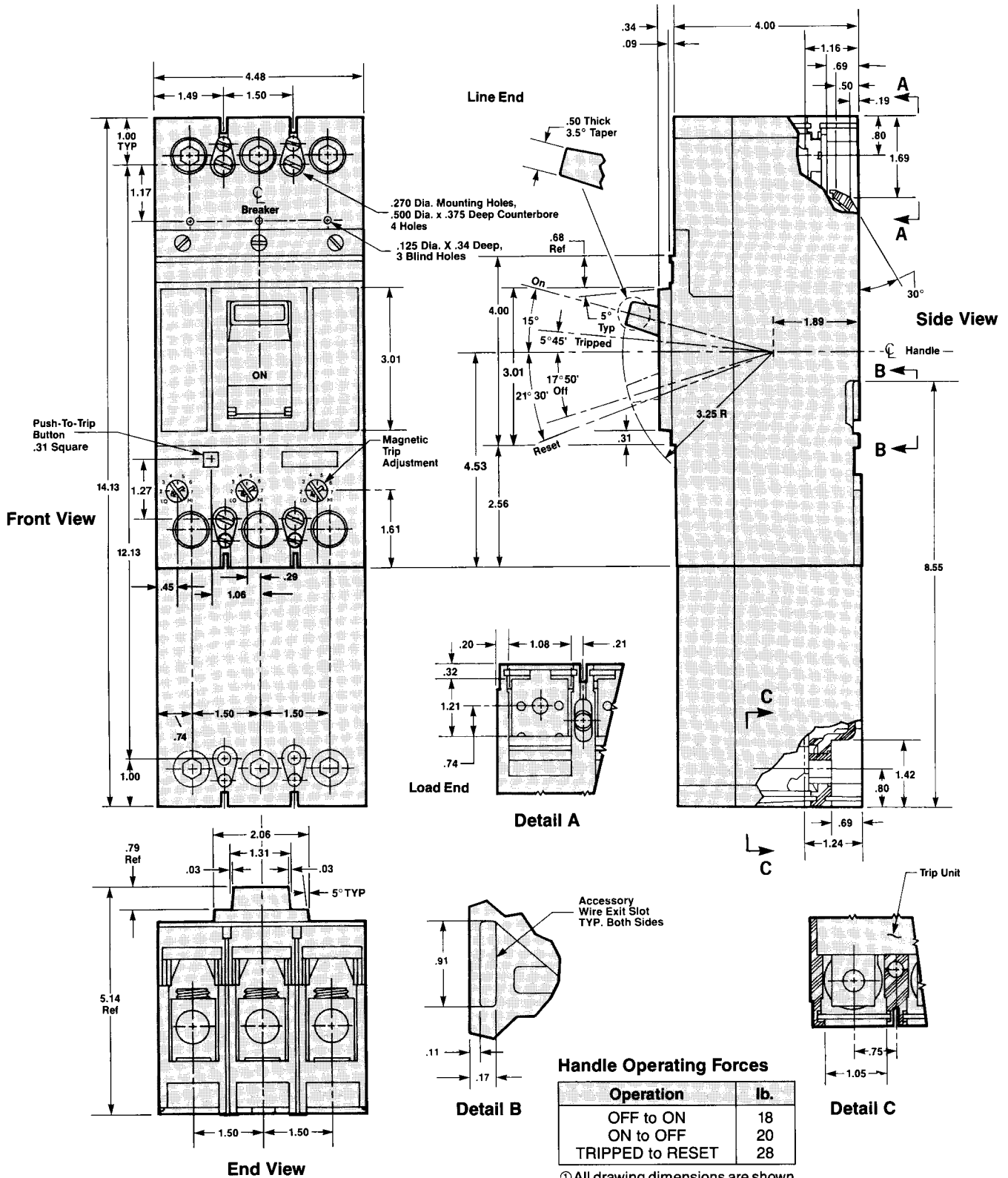

① All drawing dimensions are shown in inches.
② Two and 3-pole breakers are the same physical size. Current carrying parts are omitted from the center pole in 2-pole breakers.

I-T-E Trip Units

Add Trip Unit to Breaker Frame

A. Remove cover attachment screws (three 6-32 x $\frac{3}{8}$ in. and two 6-32 x 1- $\frac{1}{4}$ in. screws) (1) and access cover (2).

NOTE: If breaker frame is mounted, load-end breaker mounting screws must also be removed before cover can be removed.

B. Remove operating handle (3).

C. Lower trip unit assembly (4) into base. Make sure trip unit latch pin engages slots in mechanism frame.

D. Tighten three $\frac{1}{4}$ -20 x $\frac{5}{8}$ in. trip unit captive screws (5) (Recommended torque 6 ft lb.)

E. Replace operating handle (3). Operating handle must be installed with word ON toward trip unit. NOTE: Make sure operating handle is seated squarely on metal handle arm and that spherical embossments engage holes on each side of operating handle.

F. Replace access cover (2) and cover attachment screws (1) (Recommended torque 14 in. lb.) Replace load-side breaker mounting screws if applicable.

G. Check operation of circuit breaker. Reset breaker by moving handle toward load side of device until it latches. Then move handle in opposite direction until the breaker turns on. The handle will indicate ON. Depress the PUSH TO TRIP button. The breaker should trip and the handle should move to a position between ON and OFF.

H. Add the load lugs and fasten per instructions furnished with connector kits.

I. Apply rating label (6) supplied with trip unit, to recessed area on top of operating handle (3). NOTE: Make sure rating label agrees with amperage rating of trip unit installed.

J. Move operating handle (3) to extreme OFF position (reset) to latch breaker.

Replace Trip Unit in Breaker Frame

Caution: Circuit breaker must be in the TRIPPED position and breaker terminals must be disengaged from any source of power before removing cover. To trip the breaker depress the red PUSH TO TRIP button.

A. Remove cover attachment screws (three 6-32 x $\frac{3}{8}$ in. and two 6-32 x 1- $\frac{1}{4}$ in. screws) (1) and cover (2).

NOTE: If circuit breaker is mounted, load-end breaker mounting screws must also be removed before cover can be removed.

B. Remove operating handle (3).

C. Remove three $\frac{1}{4}$ -20 x $\frac{5}{8}$ in. trip unit attachment screws (5).

NOTE: Attachment screws will remain captive to trip unit assembly.

D. Remove load-end cable connector mounting screws and connectors if applicable.

E. Lift trip unit assembly (4) from circuit breaker.

F. Add new trip unit as outlined under Steps A to J of "Add Trip Unit to Breaker Frame" instructions.

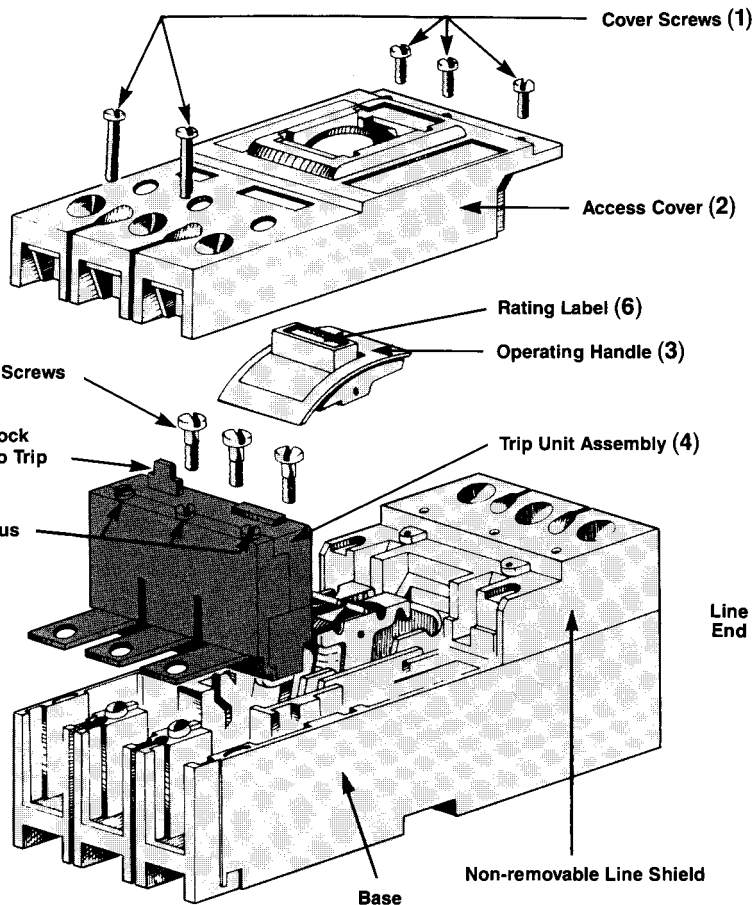

I-T-E Pressure Wire Connectors

⚠ DANGER

Hazardous Voltage.
Will cause death or severe injury.

Turn power off supplying switch-board or panel before installing.

SAFETY INSTRUCTIONS

- A. Place terminal connector body (1) (Figure 1) into terminal cavities (2) (Figure 2).
- B. Torque terminal mounting screw (3) to specified torque value.
- C. Place cable set screw (4) into threaded body opening. After cable has been inserted into cable cavity, torque cable set screw to specified value.

Solderless Connector Torque Values

Catalog Number	Terminal Screw Torque	Cable Screw Torque	Cable Range
TA1F 350	175 in. lb.	375 in. lb.	#6-350 kcmil Cu #4-350 kcmil Al
TC1F 350	175 in. lb.	375 in. lb.	#6-350 kcmil Cu
TA1FD 350	①	①	#6-350 kcmil Cu #4-350 kcmil Al
TC1FD 350	①	①	#6-350 kcmil Cu

① Consult instructions supplied with connector body.

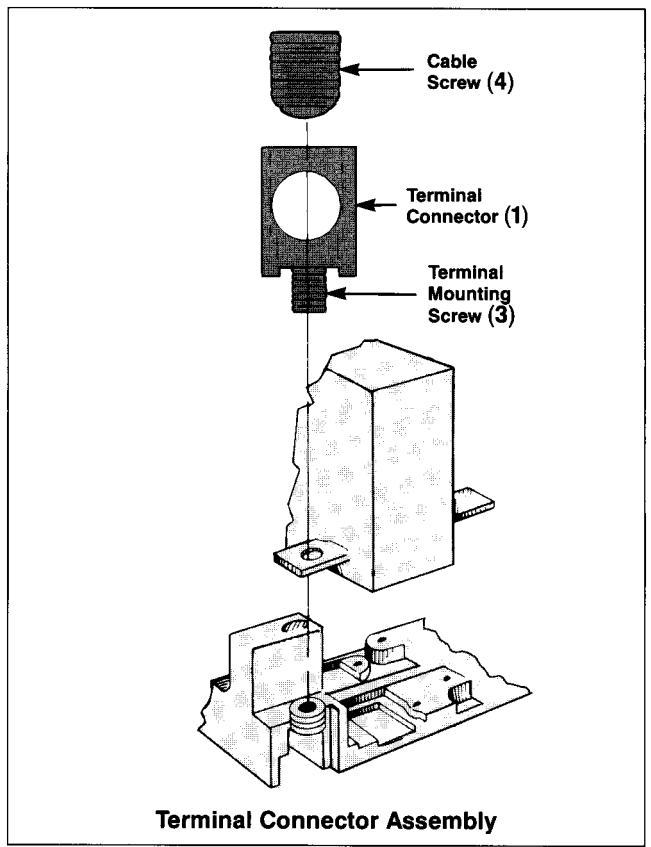
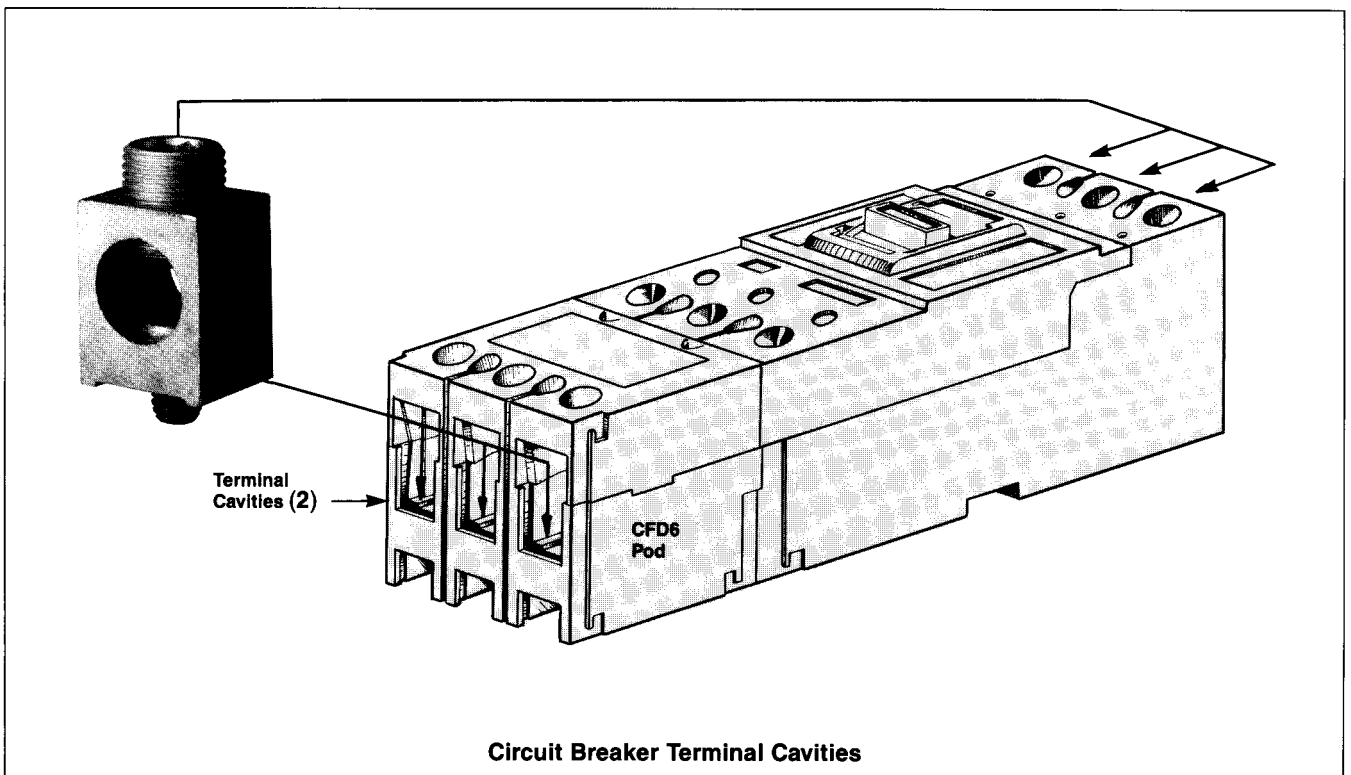

Figure 1



Circuit Breaker Terminal Cavities

Figure 2

I-T-E Compression Connector (CCF250)

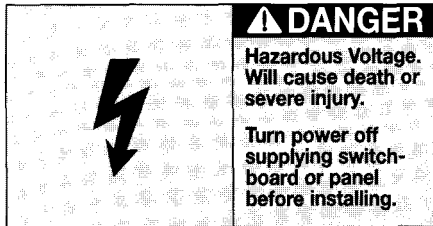

SAFETY INSTRUCTIONS

General

NOTE: This instruction sheet outlines the recommended installation procedure. Use of these lugs in some installations may result in less wire bending space than is specified in the National Electric Code.

Installation of Compression Connector

- Turn off power supplying device before installation compression lugs.
- Remove any existing wire connectors from circuit breaker.
- Install circuit breaker.
- Preform cables to final configuration and strip insulation back 1 1/8 in. on each conductor. Use an appropriate insulation stripping tool to avoid damaging the conductor. (See Figure 1.)

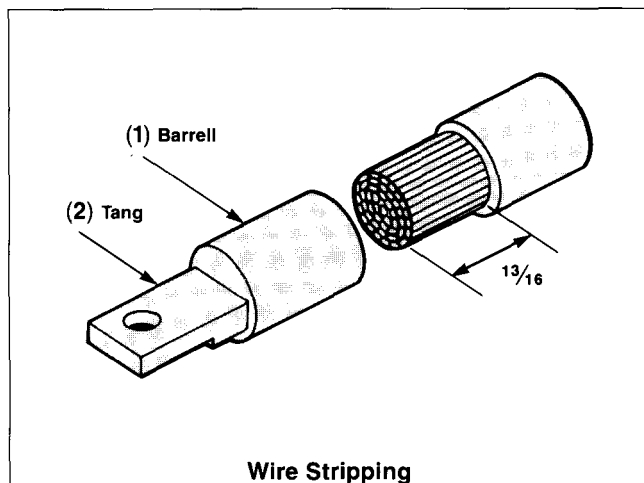

Figure 1

- Clean aluminum conductor surfaces thoroughly with a wire brush or other suitable means, to remove oxides and other contaminants from the conductor.

NOTE: Copper wires and the compression connector should not be cleaned abrasively.

- Remove cap from compression connector and insert cable fully into barrel (1) (Figure 1) of connector.
- Insure that connector tang(s) (2) (Figure 1) are in their proper orientation prior to crimping. This helps avoid twisting of cables during installation.

- Select an appropriate tool and die combination from Table 1 and make the required number of crimps within the boundaries stamped on the connector barrel. Refer to Figure 2 for sequence of multiple crimps.

Table 1—Compression Tool and Die Chart For Copper and Aluminum Conductors

Wire Size	Tool Mfr.	Tool No.	Die No.	No. of Crimps
350 kcmil	Homac	UT-5 UT-15	TX 76	6 2
350 kcmil	Burndy	Y-35	658, U29ART 249	2 1
350 kcmil	Kearny	WH-2	840	4
350 kcmil	T & B	TBM-15	76	2
#6-350 kcmil	Square D	VC-6	—	1

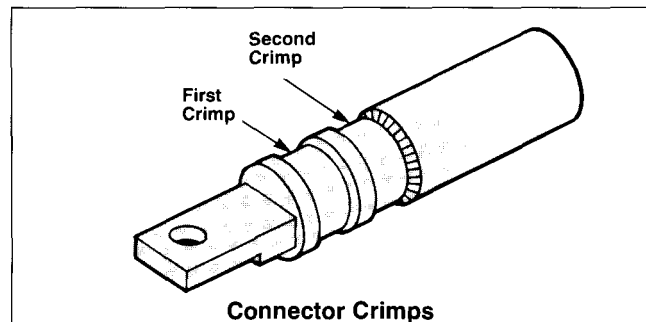

Figure 2

- Remove any inhibitor compound expelled during the crimping operation from the connector body and the cable insulation.
- Slip insulating cover over connector tang and then over connector barrel so that only the connector tang is exposed (Figure 3).

Warning: Short spacings will result if Step J is not followed.

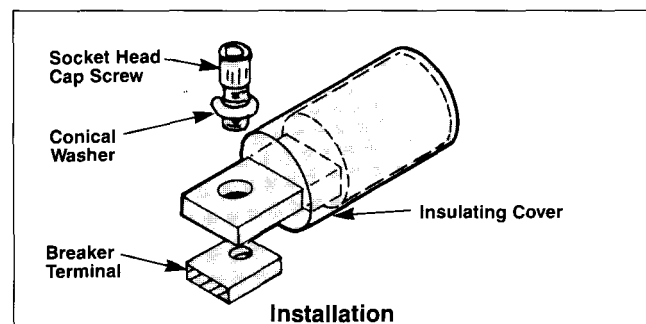

Figure 3

- Position connector tang on top of the circuit breaker terminal pad and secure with 3/8-16 x 3/4 in. socket head cap screw and conical spring washer. Conical spring washer is to be installed with convex side of washer toward underside of screw head (Figure 3). Torque screw to 175 in-lb.

I-T-E Handle Locking Devices (FD6HB1, FD6PL1)

ATTACHING I-T-E HANDLE BLOCKING DEVICE (FD6HB1)

To Block Handle ON

Turn Breaker ON. Assemble blocking device to breaker by positioning over handle as shown, with handle opening of blocking device toward the line end. Insert tab A into slot A1. Push toward handle and downward in area shown (Figure 1) until tab B drops into slot B1 (Figure 2).

To Block Handle OFF

Turn Breaker OFF. Reverse handle blocking device so that handle opening of blocking device is toward the load end. Insert tab A into slot B1. Push toward handle and downward in area shown until tab B seats in slot A1 (Figure 3).

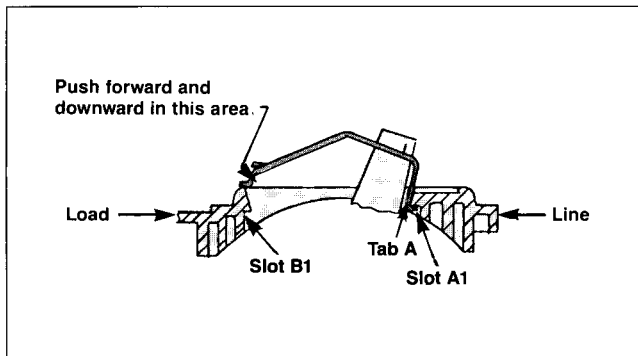

Figure 1

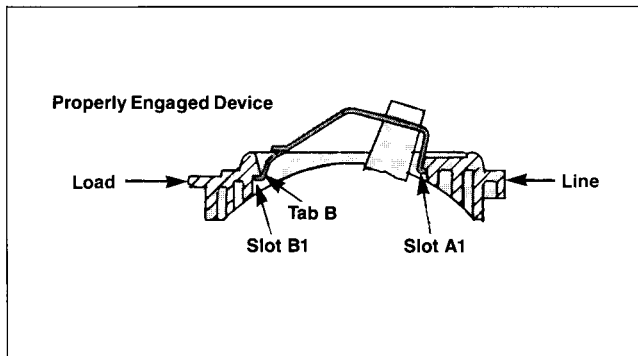

Figure 2

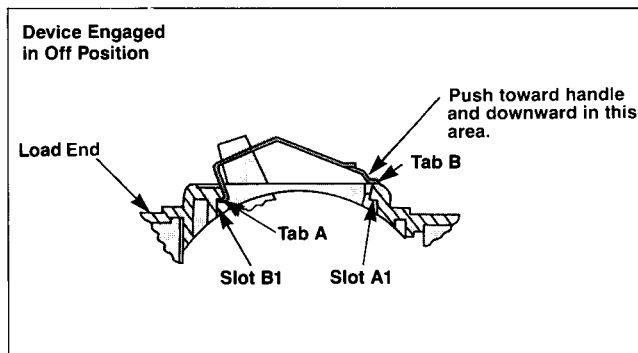

Figure 3

ATTACHING I-T-E PADLOCKING DEVICE (FD6PL1)

With breaker in TRIPPED position, assemble padlocking device to breaker by positioning over handle as shown. Insert tab A into slot A1. Pivot tab B into slot B1 until surface D is resting on surface C (Figure 4). Install #6-32 x .188 non-removable screws (2 places).

To Lock Handle OFF

To padlock handle in OFF position, move breaker handle to OFF and move slider to the left until .375 in. dia. holes line up, allowing padlock to be installed (Figure 5).

To Lock Handle ON

To padlock circuit breaker in ON position, enlarge 12 in. dia. hole of slider to .375 in. dia. before assembly to breaker. File away burrs after drilling. Assemble padlocking device to breaker as explained above, then turn breaker ON and install padlock.

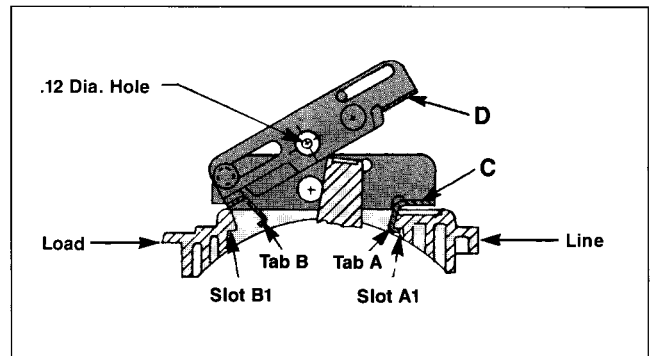

Figure 4

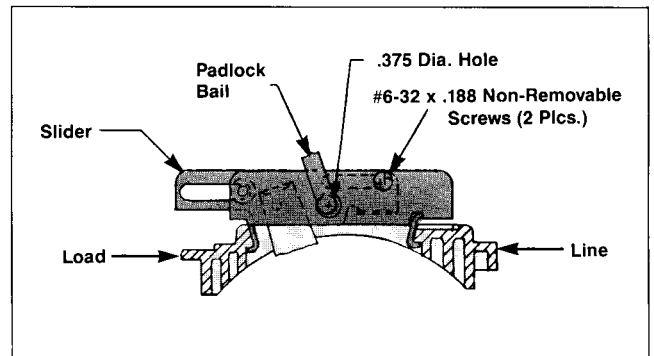

Figure 5

I-T-E Rear Connecting Studs (RS4755, RS4756)

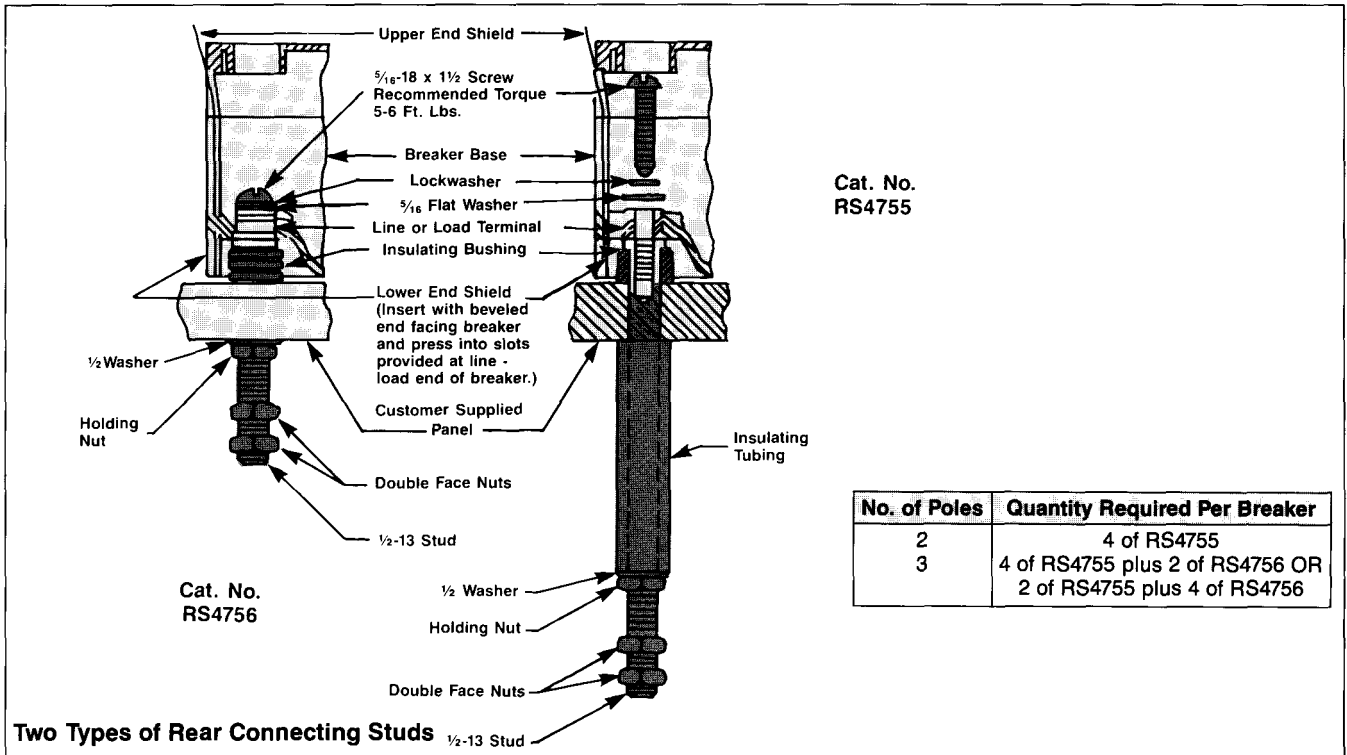

Figure 1

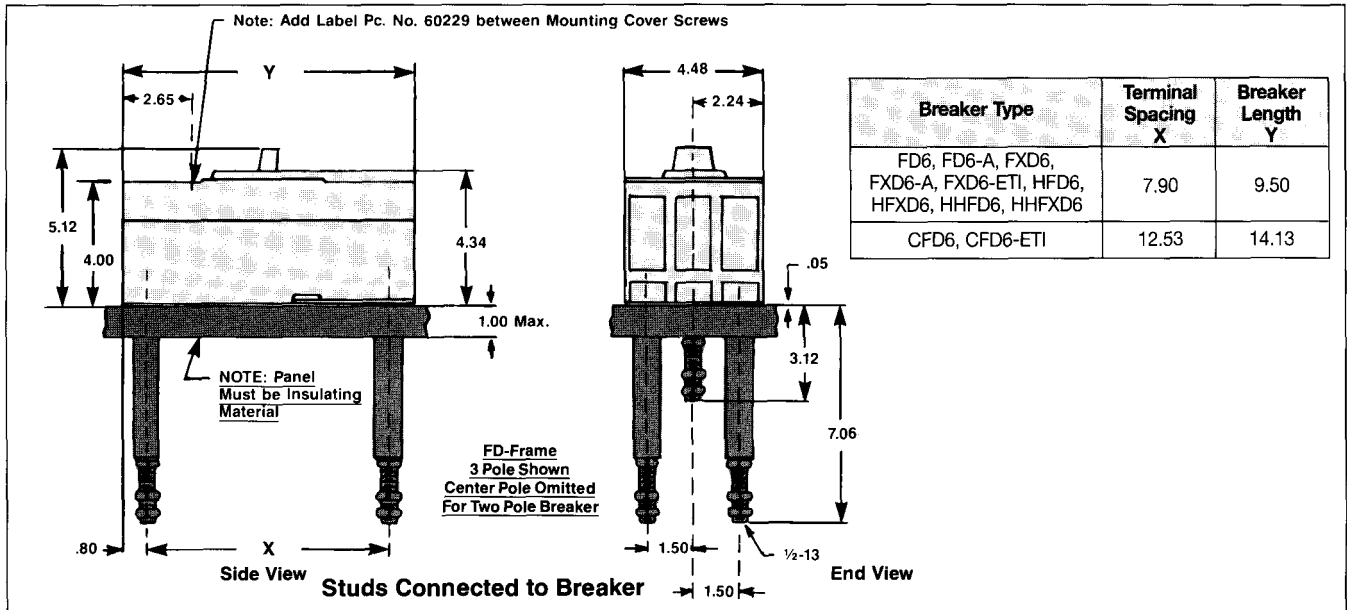

Figure 2

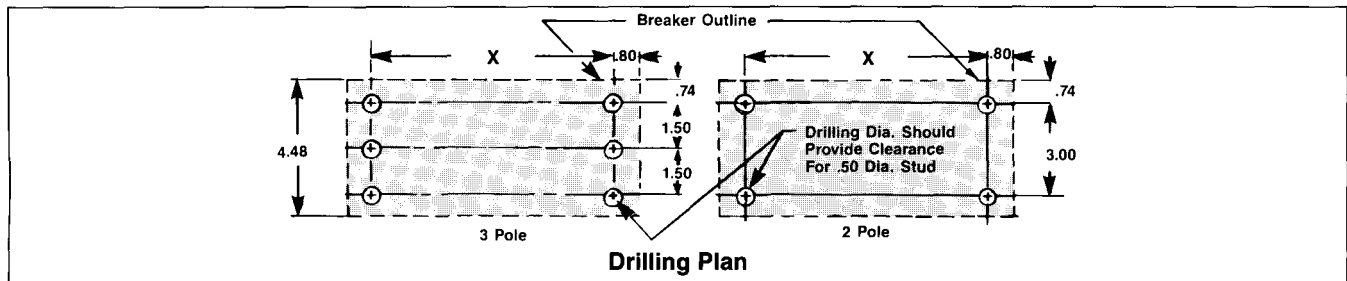
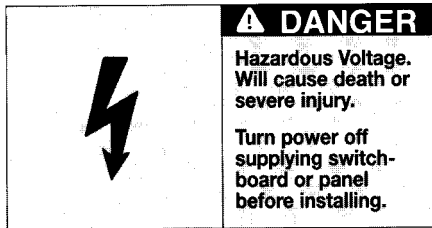

Figure 3

I-T-E Plug-In Adapters (PC4753, PC4754)



SAFETY INSTRUCTIONS

General

A complete plug-in installation requires one line end adapter assembly (consisting of a mounting block, tulip connectors and associated hardware), one load end adapter assembly and one switchboard mounting plate. The switchboard mounting plate is optional and can be replaced by other mounting means to suit customer's requirements.

Application Information

Breaker Type	No. of Poles	Line End Adapter	Load End Adapter	Switchboard Mtg. Plan
FD6, FD6-A, FXD6, FXD6-A, FXD6-ETI, HFD6, HFXD6, HHFD6, HHFXD6	2 3	PC4753 PC4754	PC4753 PC4754	PL4762 PL4762
CFD6, CFD6-ETI	2 3	PC4753 PC4754	PC4753 PC4754	PL4763 PL4763

Mounting Preparation (Figures 1 and 2)

- A. If the optional switchboard mounting plate (1) is to be used, provide drilling as shown in Figure 1.
- B. If other mounting means are to be used, provide the cutouts and drilling required to mount the adapter blocks as shown in Figure 2.

Switchboard Mounting Plate, if used (Figure 3)

- A. Place switchboard mounting plate (1) in position at location previously prepared in Step A above. Secure in place with $\frac{5}{16}$ in. hardware (furnished by customer).

Mounting Block (Figure 3)

- A. Align mounting block (2) with cutouts in switchboard mounting plate (or customer's mounting means as previously prepared in Step B above) and secure in place with $\frac{3}{8}$ in. flatwashers (3), lockwashers (4) and $\frac{3}{8}$ -16 hex nuts (5) furnished.

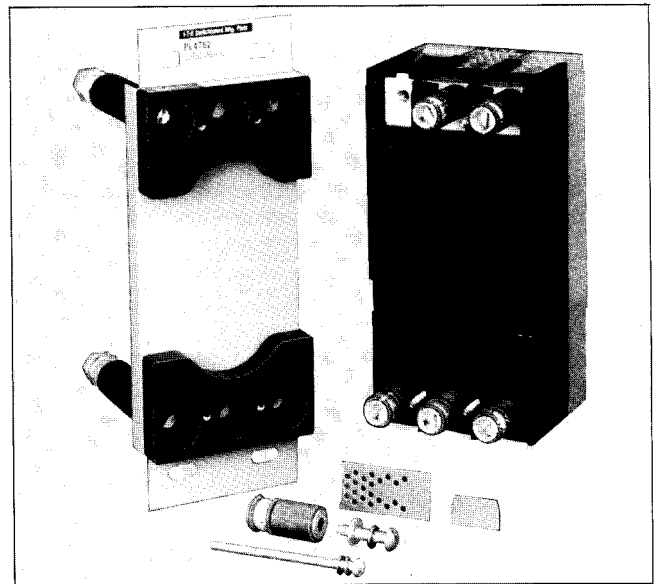

Breaker Preparation (Figure 4)

- A. Remove pressure wire connectors from breaker if present. Place tulip clip assembly (6) on back of breaker in recess provided in base molding. Secure in place with $\frac{5}{16}$ in. flatwashers (7), lockwashers (8) and $\frac{5}{16}$ -18 x 1- $\frac{1}{2}$ round head screws (9) furnished. Recommended tightening torque for these bolts is 5-6 ft. lb. to assure a good electrical connection. Repeat this procedure for the remaining tulip clip assemblies.
- B. Slide upper end shields (10) and insert lower and shields (11) with beveled end facing breaker and press into slots provided at line and load end of breaker.
- C. Add accessory label (12) to top of breaker as indicated in Figure 5.

Final Assembly (Figure 6)

- A. Make bus and/or cable connection to rear of mounting block studs using hex nuts (13) furnished to secure this connection.

Caution: Make certain that breaker operating handle is in the OFF position before proceeding with the next step.
- B. Align breaker with mounting blocks and force female tulip clips over male studs in mounting block until breaker base bottoms against mounting block. Secure breaker in place with $\frac{1}{4}$ -20 x 4- $\frac{1}{4}$ in. mounting screws (14), lockwashers (15), and flatwashers (16) furnished.
- C. If installation requires the use of front panel trim, provide cutout for breaker escutcheon (Figure 7).

Installation Diagrams

Dimensions (In Inches)

Breaker Type	A	B	C
FD6, FD6-A, FXD6, FXD6-A, FXD6-ETI, HFD6, HFXD6, HHFD6, HHFXD6	12.5	10.75	7.9
CFD6, CFD6-ETI	17.13	15.38	12.53

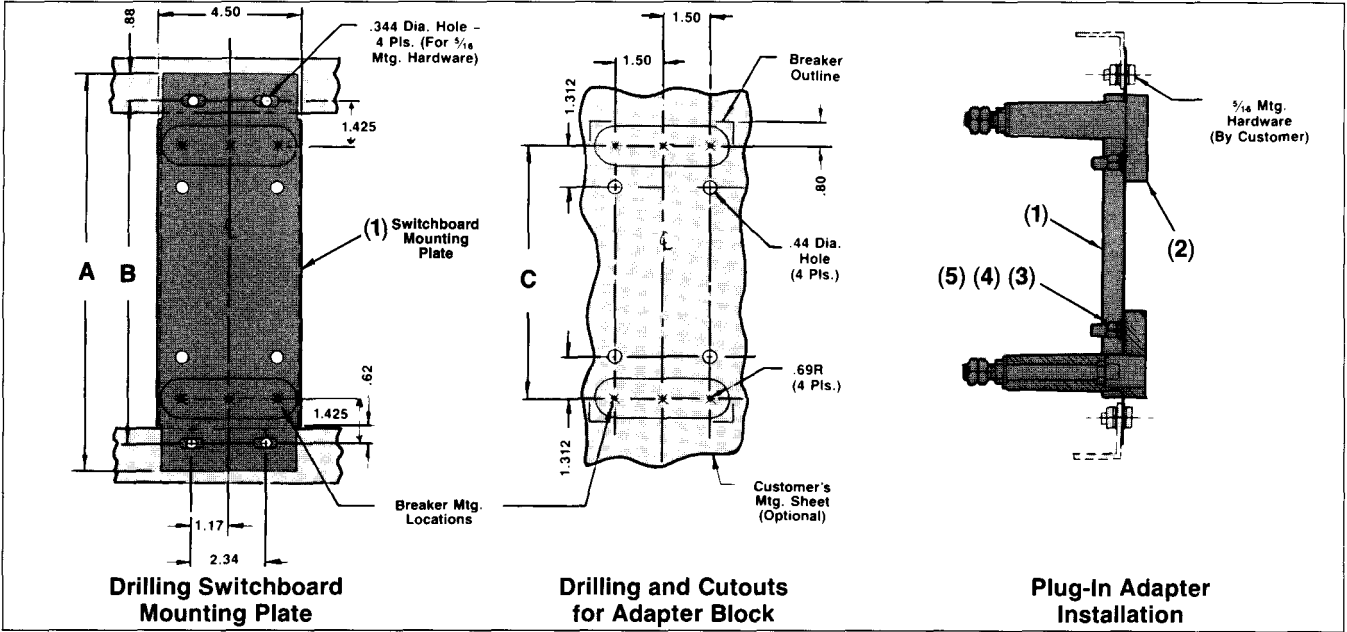

Figure 1

Figure 2

Figure 3

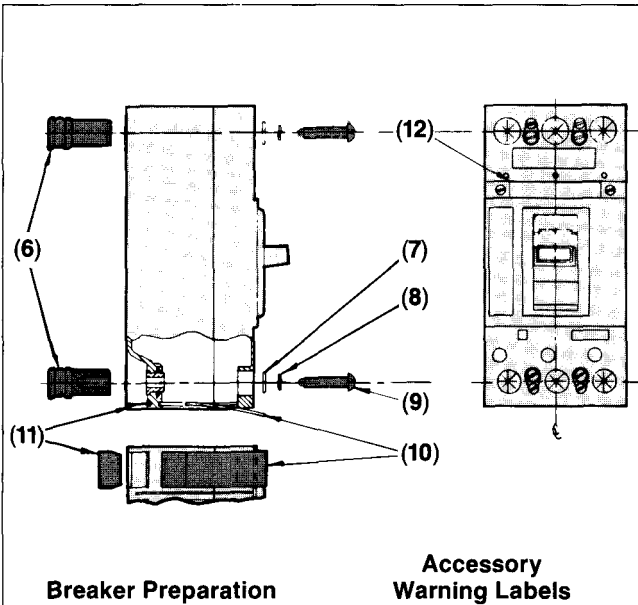

Figure 4

Figure 5

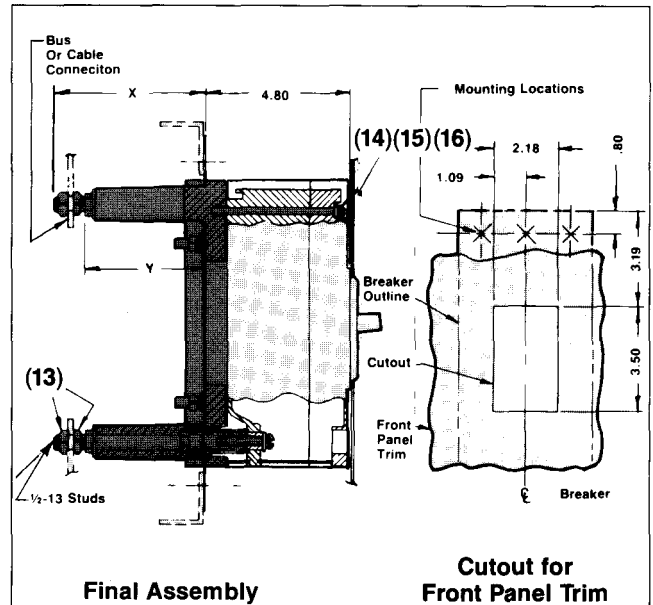

Figure 6

Figure 7

Dimensions (In Inches)

Pole	X	Y
Center	2.77	1.67
Left/Right	5.08	4.0

I-T-E Walking Beam Type Interlock

Panel Mounted and Plug-In Mounted Circuit Breakers (MI5444)

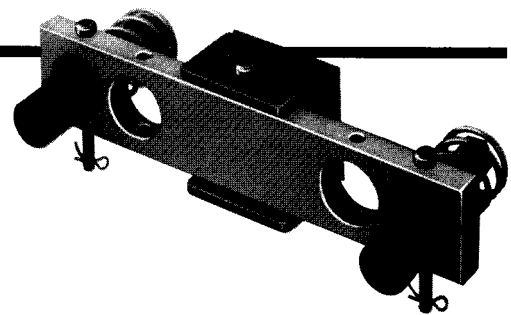

⚠ DANGER

Hazardous Voltage. Will cause death or severe injury.

Turn power off supplying switchboard or panel before installing.

SAFETY INSTRUCTIONS

Circuit Breaker Preparation and Mounting (Figures 1, 2 and 3)

- A. Turn OFF and lock out all power supplying the circuit breaker before installing.
- B. Drill panel as shown in Figure 1 for panel mounted or Figure 2 for plug-in mounted.
- C. Using a screwdriver, break out the proper knockout in circuit breaker base, as shown in Figure 3. Use a needle file to smooth the opening to indicated dimensions. DO NOT ALLOW PLASTIC PIECES TO ENTER THE BASE. Check to see that the plunger (8) moves freely within the opening, as shown in Figure 4.
- D. Attach support (1) and spacers (2) to rear of panel using screws (3), lockwashers (4) and nuts (5) supplied, as shown in Figure 4. Tighten to 32 in. lbs.

NOTE: 0.015 in. thick spacers are provided. Choose the correct quantity for your panel using the following chart.

Gauge No.	Nominal Thickness In.	Qty. of Spacers
10	0.135	2
11	0.120	3
12	0.105	4
13	0.090	5
14	0.075	6
16	0.060	7

Caution: Mount the circuit breakers and the interlock support on one single rigid panel. A crossbrace is recommended for long unsupported mounting panel surfaces to prevent flexing of the mounting panel. Failure to follow this information could cause improper interlock functioning.

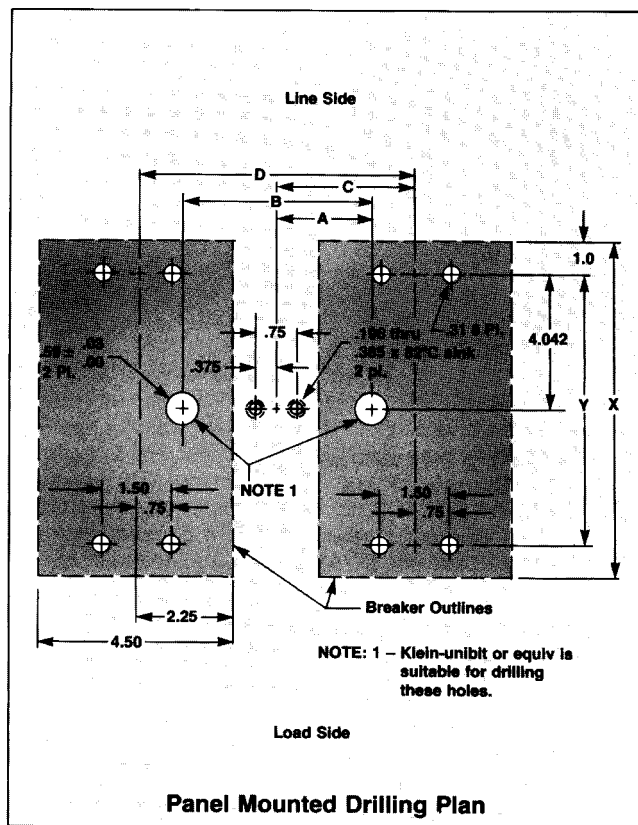

Figure 1

Dimensions (In Inches)

Breakers On	A	B	C	D
4.50 In. Centers	1.273	2.546	2.25	4.50
6.00 In. Centers	2.023	4.046	3.00	6.00

Breaker Type	X	Y
FD6, FD6-A, FXD6, FXD6-A, FXD6-ETI, HFD6, HFXD6, HHFD6, HHFXD6	9.50	7.50
CFD6, CFD6-ETI	14.13	12.13

Installation

Caution: Malfunction of the Mechanical Interlock could occur if the dimensions shown in Figures 1, 2 and 4 are not maintained. This could result in property damage. Make sure that all interface dimensions remain fixed during the service life of the interlock and breakers.

Rocker Arm Assembly (Figure 4)

- A. Attach rocker arm (6) to the support (1) using the rocker arm pin (7). Washers (11) must be located inside the support, with one on each side of the rocker arm. Insert cotter pin (9) into hole of pin (7) and spread ends.
- B. Place one centering spring (10) between the panel and the rocker arm, centering it over the correct hole, as shown in Figure 4. Insert the plunger (8) through the spring and rocker arm, being certain that the plunger is oriented as shown in Figure 4.
- C. Attach the rocker arm (6) to the plunger (8) using a rocker arm pin (7). Use the plunger hole closest to the circuit breaker for panel mounted breakers and the most distant hole for plug-in mounted breakers. Insert cotter pin (9) into hole of pin (7) and spread ends.
- D. Compress the installed spring by rotating the rocker arm. Complete the assembly for the second circuit breaker by repeating steps B and C.

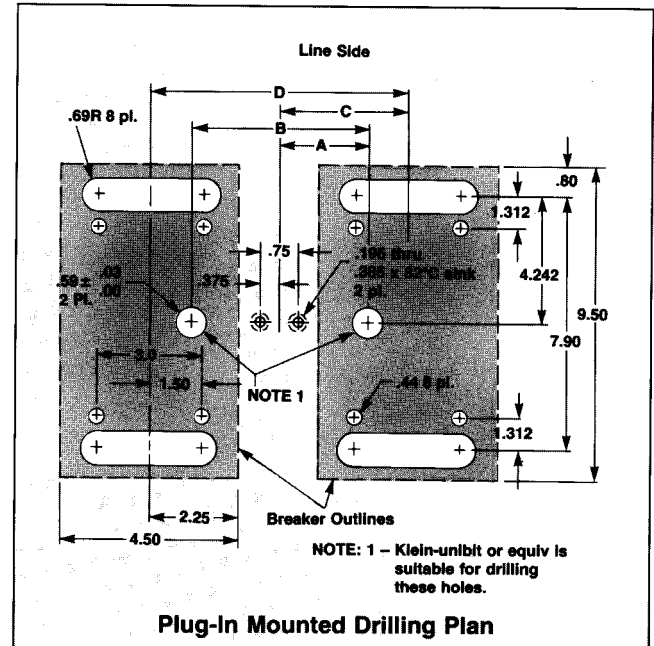

Figure 2

Dimensions (In Inches)

Breakers On	A	B	C	D
4.50 In. Centers	1.273	2.546	2.25	4.50
6.00 In. Centers	2.023	4.046	3.00	6.00

Breaker Type	X	Y
FD6, FD6-A, FXD6, FXD6-A, FXD6-ETI, HFD6, HFXD6, HHFD6, HHFXD6	9.50	7.90
CFD6, CFD6-ETI	14.13	12.53

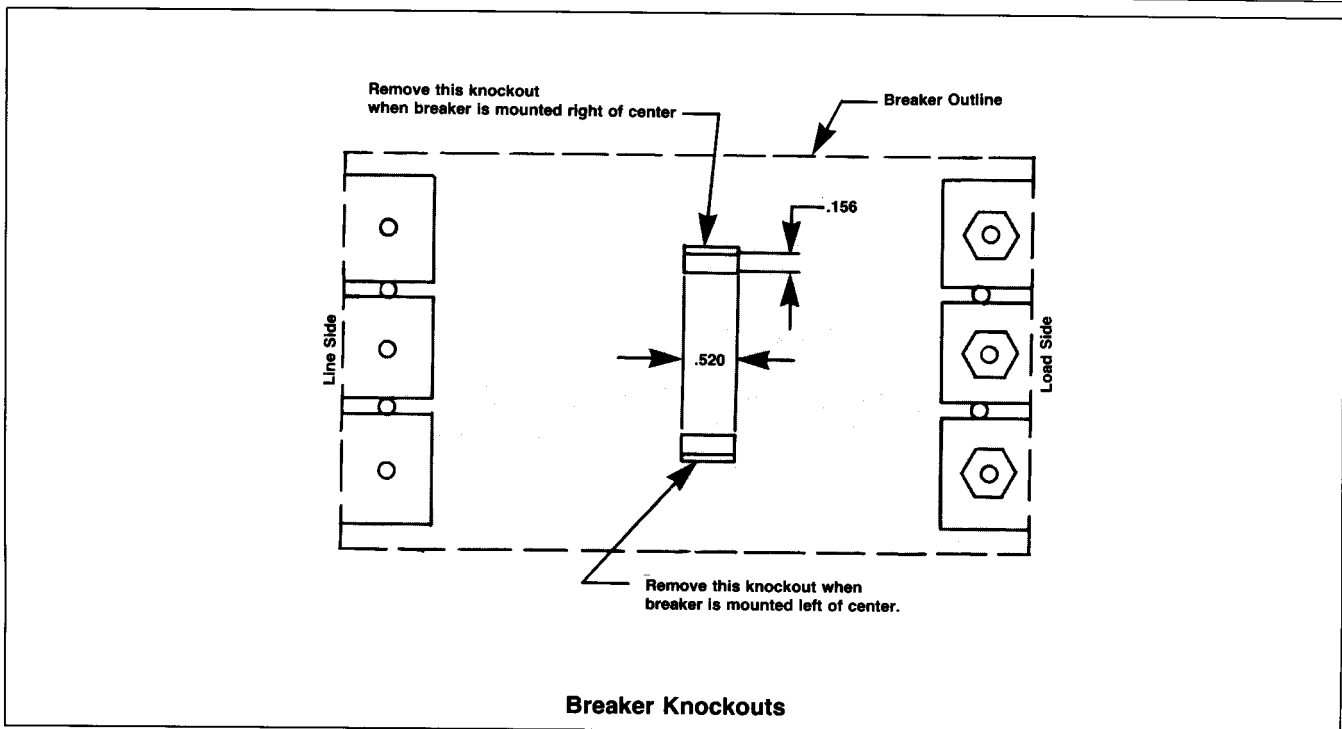

Figure 3

I-T-E Walking Beam Type Interlock

Panel Mounted and Plug-In Mounted Circuit Breakers (MI5444)

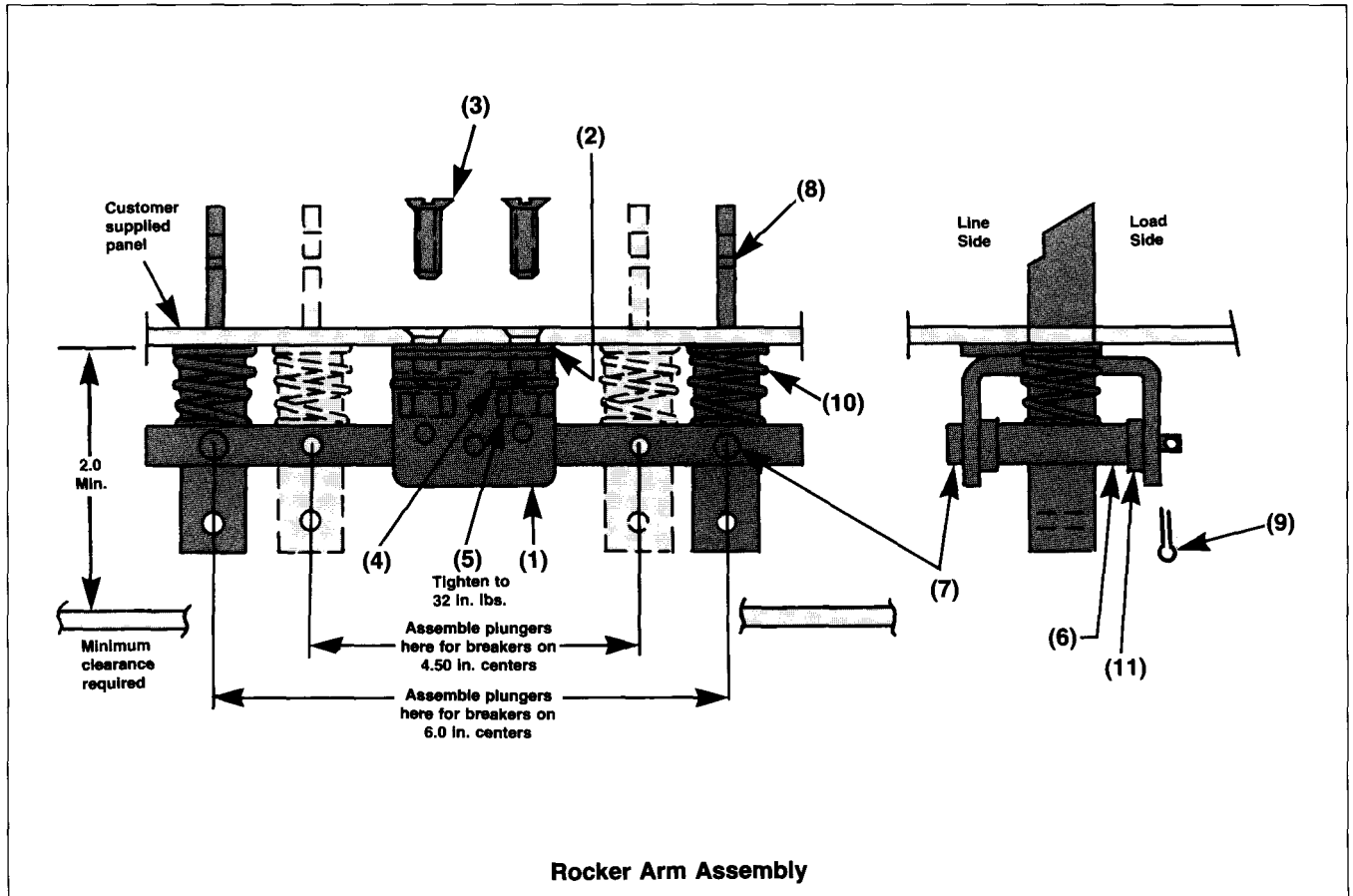

Figure 4

Check Operation

NOTE: The Mechanical Interlock plungers (8) are actuated by cam surfaces located in the circuit breakers. Due to mounting panel thickness variations, surface irregularities and system tolerances, you may need to add or remove spacers (2) to adjust interface dimensions. Follow the steps below to determine.

- A. Check the ON-OFF function of each circuit breaker. If the ON-OFF operation is normal, proceed to step C.
- B. If either circuit breaker cannot be turned ON, loosen the support screws (3) shown in Figure 4, and install one additional spacer (2). Retighten the screws to 32 in. lbs. Repeat step A. Additional spacers can be installed, if required.

C. The interlock will prevent CLOSING of one or both of the circuit breakers if they are simultaneously driven to the ON position. Check this function by manually turning both circuit breakers ON using toggle handles.

D. If both breakers CLOSE, loosen the support screws (3) and remove one of the spacers (2). Retighten the screws to 32 in. lbs. Repeat step C. A second spacer can be removed if required.

Caution: Avoid unnecessary simultaneous TURN ON operations. They cause high mechanical loading of the circuit breaker and interlock components.

E. Recheck each circuit breaker for normal ON-OFF operations.

F. Turn each circuit breaker ON and confirm that the other circuit breaker cannot be closed.

Installation

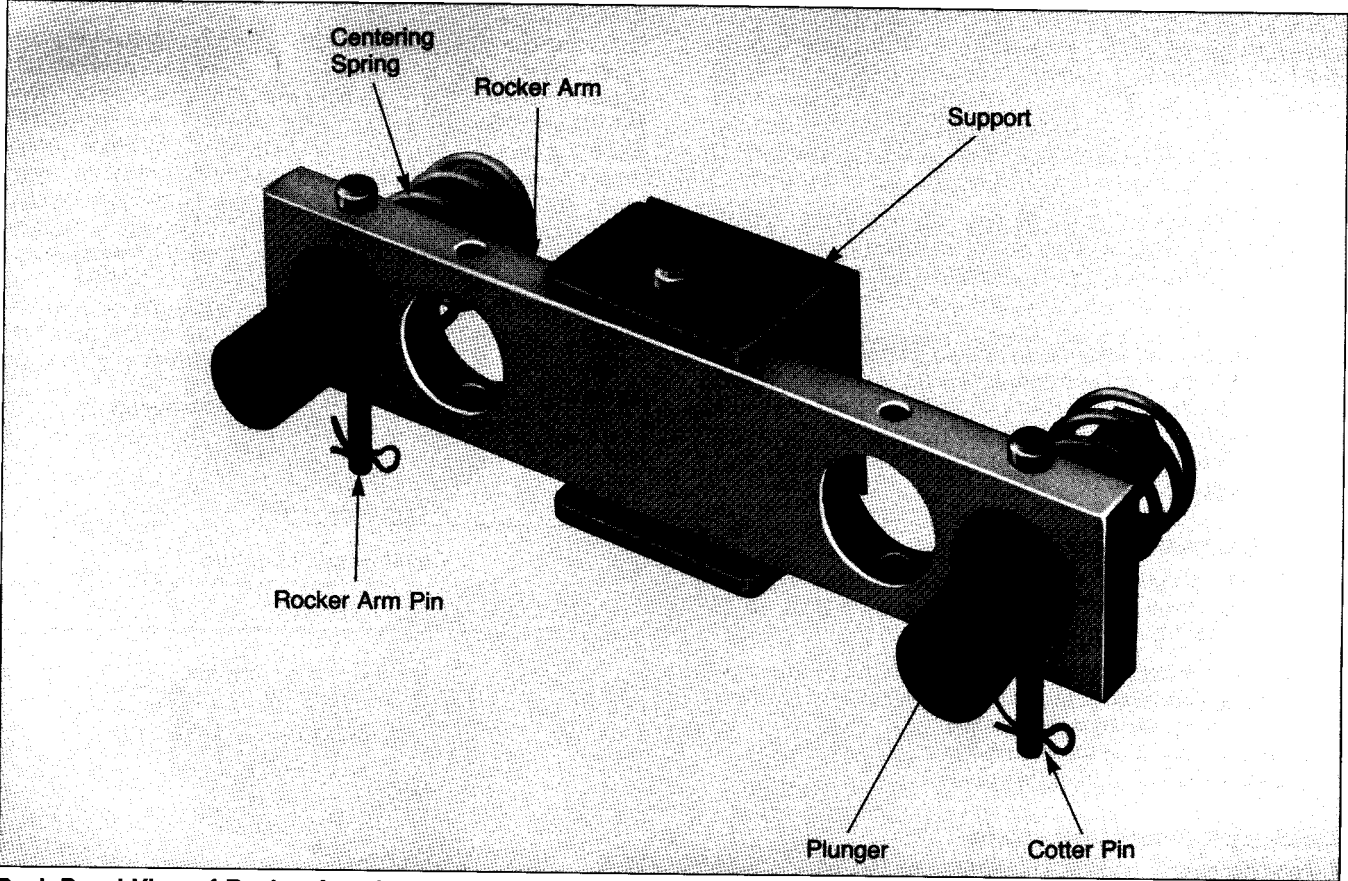

Back Panel View of Rocker Arm Assembly

I-T-E Shunt Trip, Undervoltage Trip and Auxiliary Switch

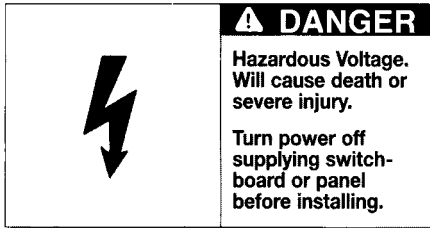

⚠ SAFETY INSTRUCTIONS

Caution: Accessory installation should be completed *before* the breaker is mounted and connected. If breaker is installed, **BE SURE TO TURN POWER OFF SUPPLYING BREAKER** before installing accessory. It is highly recommended that breaker be disconnected and removed from panel or enclosure to install accessories.

Circuit Breaker Preparation

- A. Depress trip button (Figure 1) to trip circuit breaker prior to removing cover. Before attaching accessory unit, circuit breaker must be in tripped position.
- B. Remove five load end cover screws (1) and, if breaker is mounted, also remove mounting screws (2). Remove load end cover only (3). For ease of installation, handle and handle barrier may also be removed. Accessory units can be mounted in either right or left poles of the circuit breaker.

Accessory Mounting Instructions

- A. Feed accessory leads down and through $1\frac{5}{16} \times \frac{5}{32}$ in. elongated opening (4) to bring leads out of bottom of circuit breaker (Figure 3). **NOTE:** Leads must be brought out in the same order as they exit wire retainer of accessory case.
- B. Accessory is located in circuit breaker by two ribs (5), one on each side of accessory.

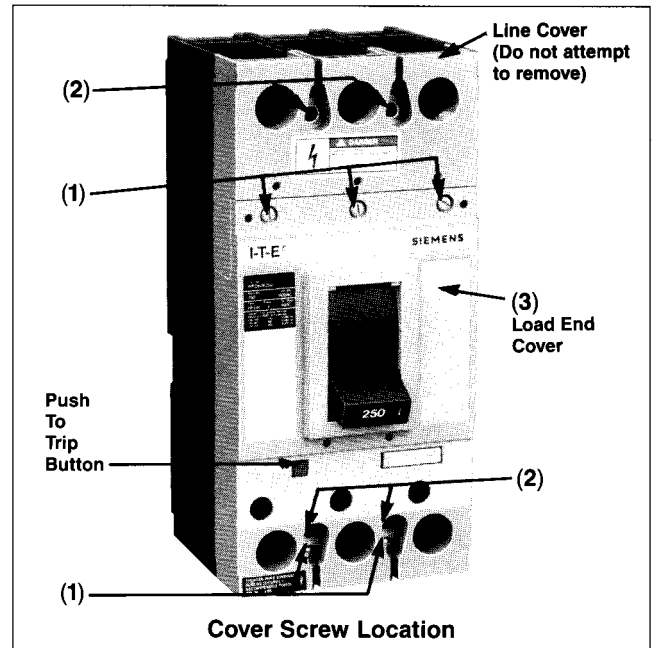

Figure 1

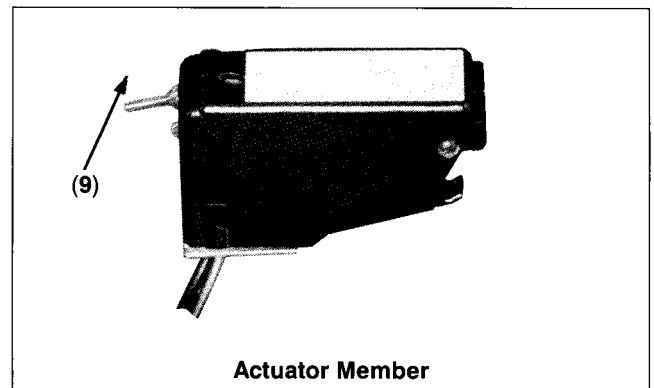

Figure 2

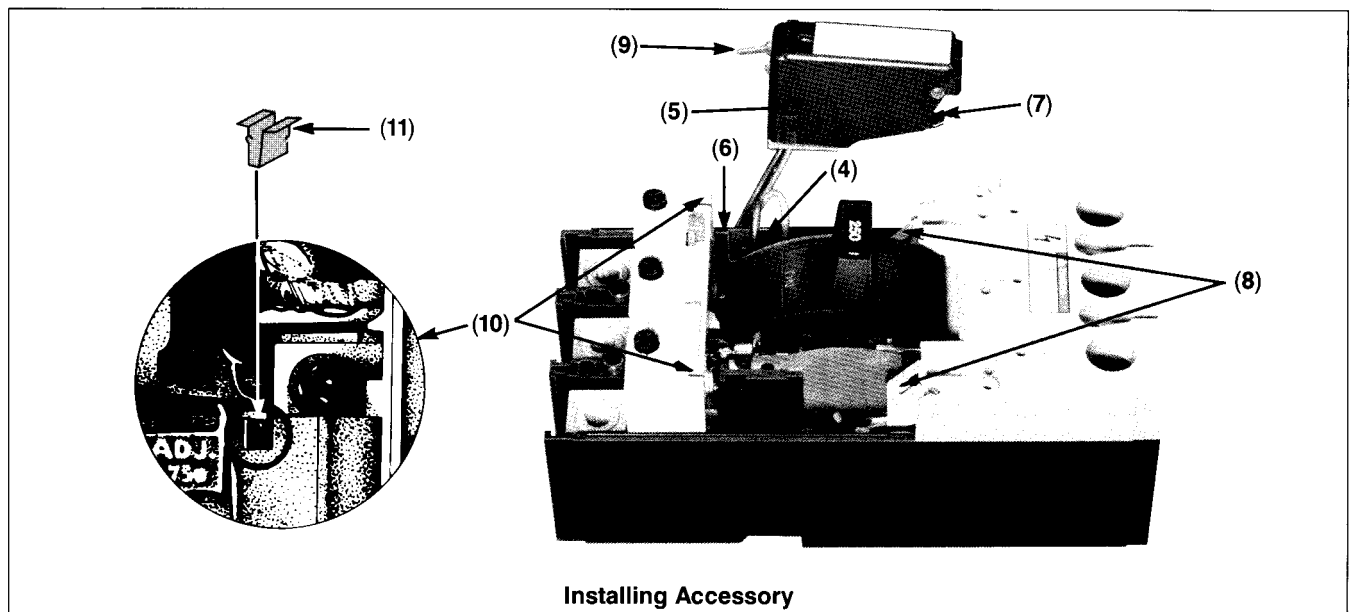

Figure 3

Installation

For Shunt Trip and Undervoltage Trip Units:

Push a small diameter pin through center of label on top of accessory until device delatches. Remove the protective label covering the opening in the trip unit (10) from the pole in which the accessory is to be mounted. To install the accessory, tilt the end with the transfer link (9) down and lower the accessory into the breaker, guiding the latch lever foot (7) under the edge of the line cover (8) and the tab on the accessory into the slot on top of the line cover (8). When the lever foot clears the line cover, rotate the accessory parallel with the breaker and lower into position while guiding the transfer link (9) into the opening (10) at the top of the trip unit. Pull gently and evenly on accessory wire leads while lowering accessory into base. Make sure *all the slack* is removed from leads inside breaker. Insert the retainer clip (11) in opening (10) of the trip unit so that the 90° tabs rest on the top surface of the trip unit. The retainer clip (11) now retains the transfer link (9) in the opening (10).

For Auxiliary Switch Trip Unit:

Slide accessory ribs down into two grooves (6) in base. When accessory is installed correctly, tops of ribs on side of accessory will be at same level as top outside edge of circuit breaker base and front of accessory will rest on sloped surface (8) of line shield. Pull gently and evenly on accessory wire leads while lowering accessory into base. Make sure *all the slack* is removed from leads inside breaker.

C. Replace load end cover and five cover screws (recommended torque 14 lb. in.) and mounting screws if mounted.

D. Add two labels to circuit breaker. Attach identification label (12) to appropriate space in label on top of circuit breaker on right hand side. Attach accessory information label (13) on side of circuit breaker base (Figure 5).

E. Refer to Electrical Check, pages 22 and 23.

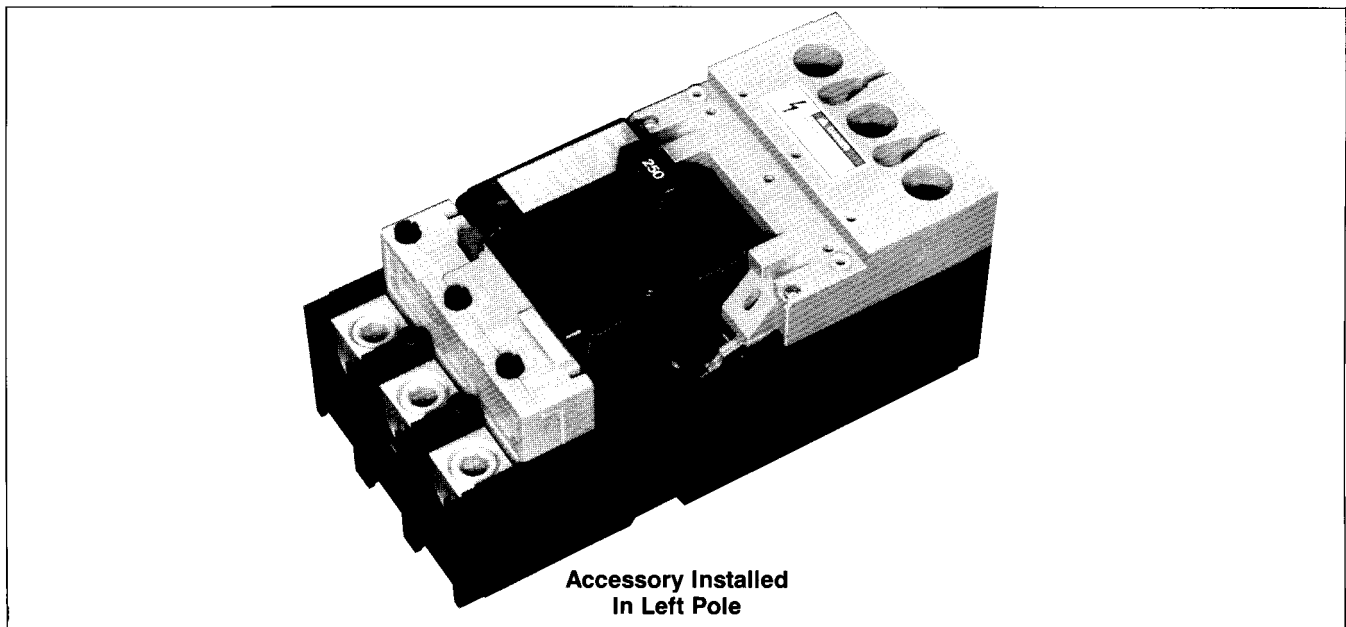

Figure 4

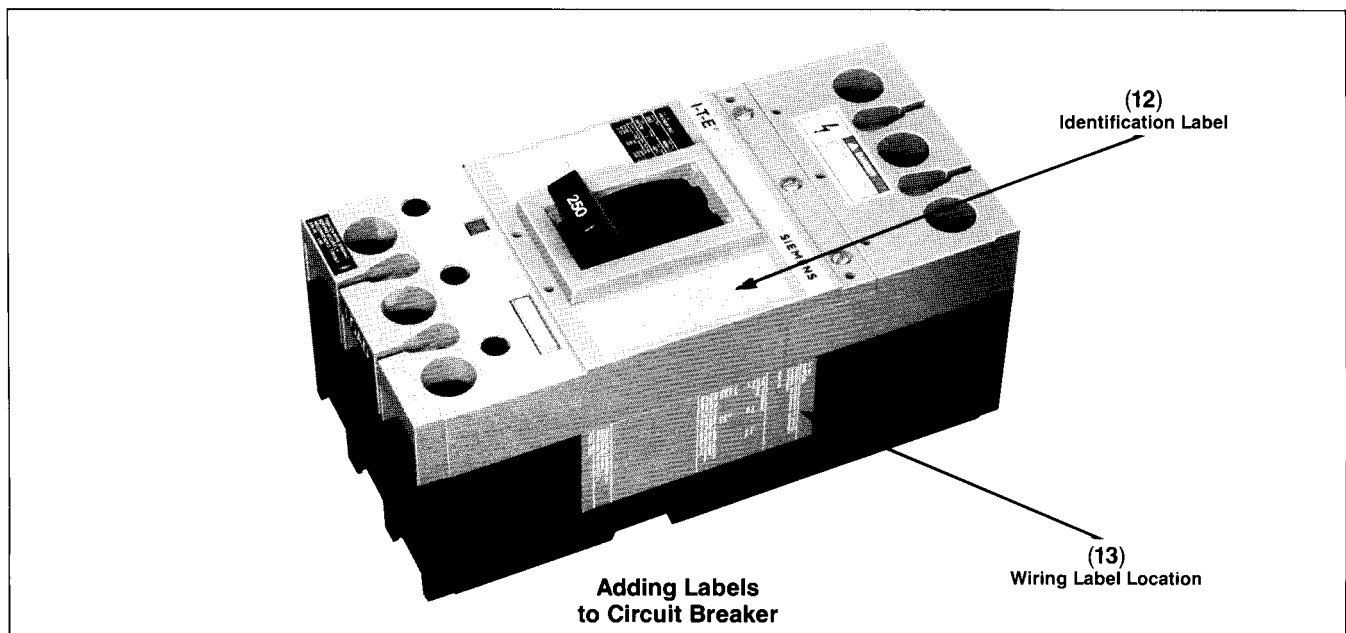

Figure 5

I-T-E Bell Alarm Switch

Caution: Accessory installation should be completed *before* the breaker is mounted and connected. If breaker is installed, **BE SURE TO TURN OFF POWER SUPPLYING BREAKER** before installing accessory. It is highly recommended that breaker be disconnected and removed from panel or enclosure to install accessories.

Circuit Breaker Preparation

- A. Depress trip button (Figure 1) to trip circuit breaker prior to removing cover. Before attaching accessory unit, circuit breaker must be in tripped position.
- B. Remove five load end cover screws (1) and if breaker is mounted, also remove mounting screws (2). Remove load end cover (3) and handle with barrier (4). Accessory units can be mounted in either right or left poles of the circuit breaker.

Accessory Mounting Instructions

- A. Snap-in actuator member (5) at $\frac{5}{16}$ in. square opening of accessory housing into microswitch actuator (.05 x .23 in. slot). Figure 3 shows accessory unit ready for installation in left pole of circuit breaker. If right pole mounting is desired, insert actuator member on opposite side.

Caution: Do not distort actuating lever.

- B. Feed accessory leads down and through $1\frac{5}{16} \times \frac{5}{32}$ in. elongated opening (6) to bring leads out the bottom of circuit breaker. **NOTE:** Leads must be brought out in the same order as they exit wire retainer of accessory case.
- C. Accessory is located in circuit breaker by two ribs (7), one on each side of the accessory. Slide accessory ribs down into two grooves (8) in base. When accessory is installed correctly, tops of the ribs on side of the accessory will be at the same level as the top outside edge of the circuit breaker base and front of the accessory (9) will rest on pad (10) of line shield (Figure 4). Pull gently and evenly on accessory wire leads (3 to 6 wires) while lowering accessory into base. Make sure actuator member (5) rests in the recess of the operating mechanism frame (pivoting point) and *all the slack* is removed from leads inside breaker.

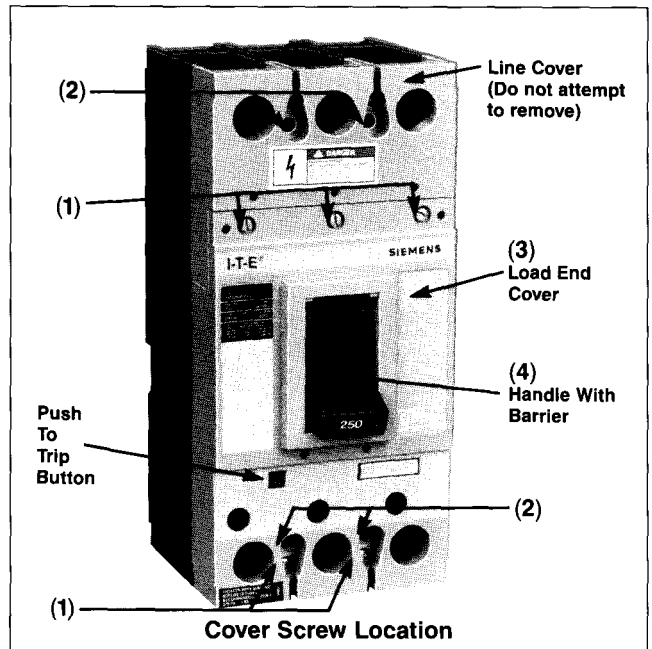

Figure 1

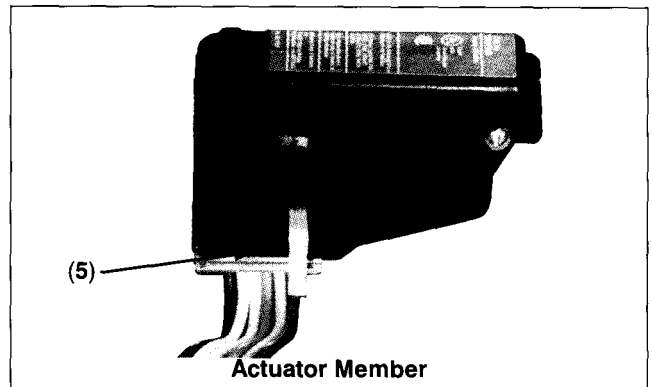

Figure 2

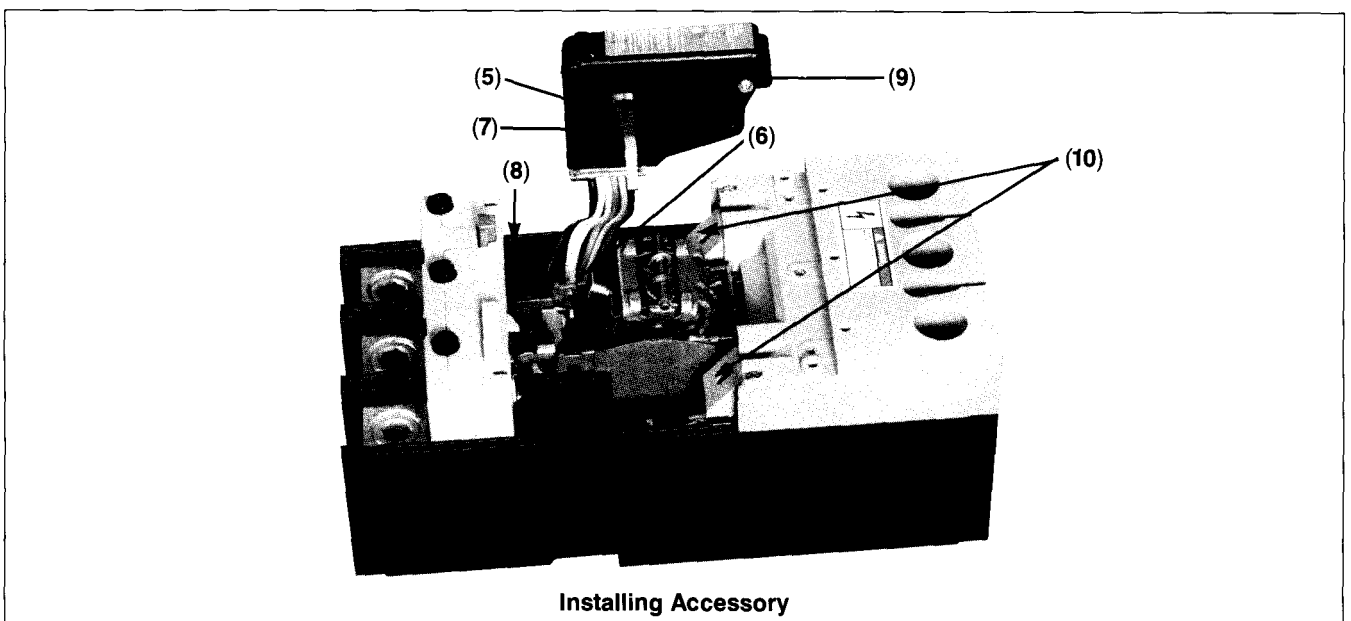

Figure 3

Installation

Recommended Combinations

- D. Replace handle with barrier, load end cover and five cover screws (recommended torque 14 in. lb.) and mounting screws if mounted (Figure 1).
- E. Add the two labels provided to circuit breaker. Attach identification label (11) to appropriate space in label on top of the circuit breaker on the right hand side. Attach accessory information label (12) on side of the circuit breaker base (Figure 5).
- F. Refer to Electrical Check, page 23.

Maximum Installable Accessory Combinations

Shunt Trip ^①	Undervoltage Trip	Auxiliary Switch	Bell Alarm Switch
1	1	1	0
1	0	2	0
1	0	1	1
0	1	3	0
0	1	2	1
0	0	3	1
0	0	4	0

① Shunt trip units include a coil clearing switch.

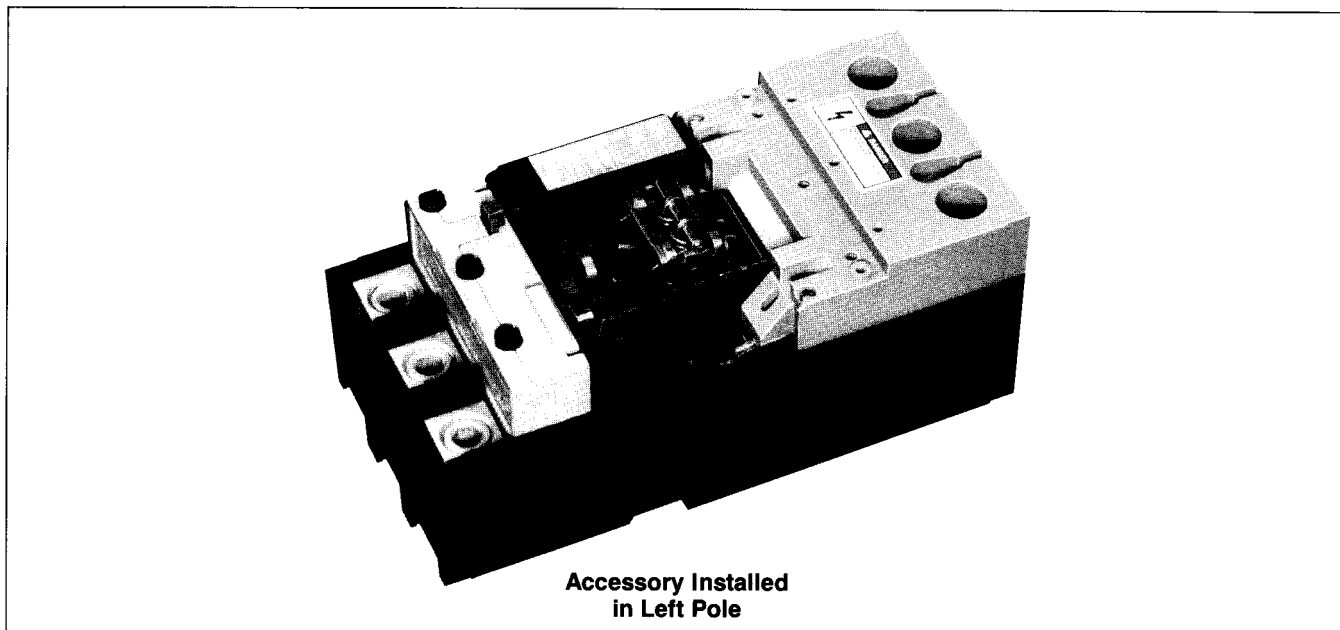

Figure 4

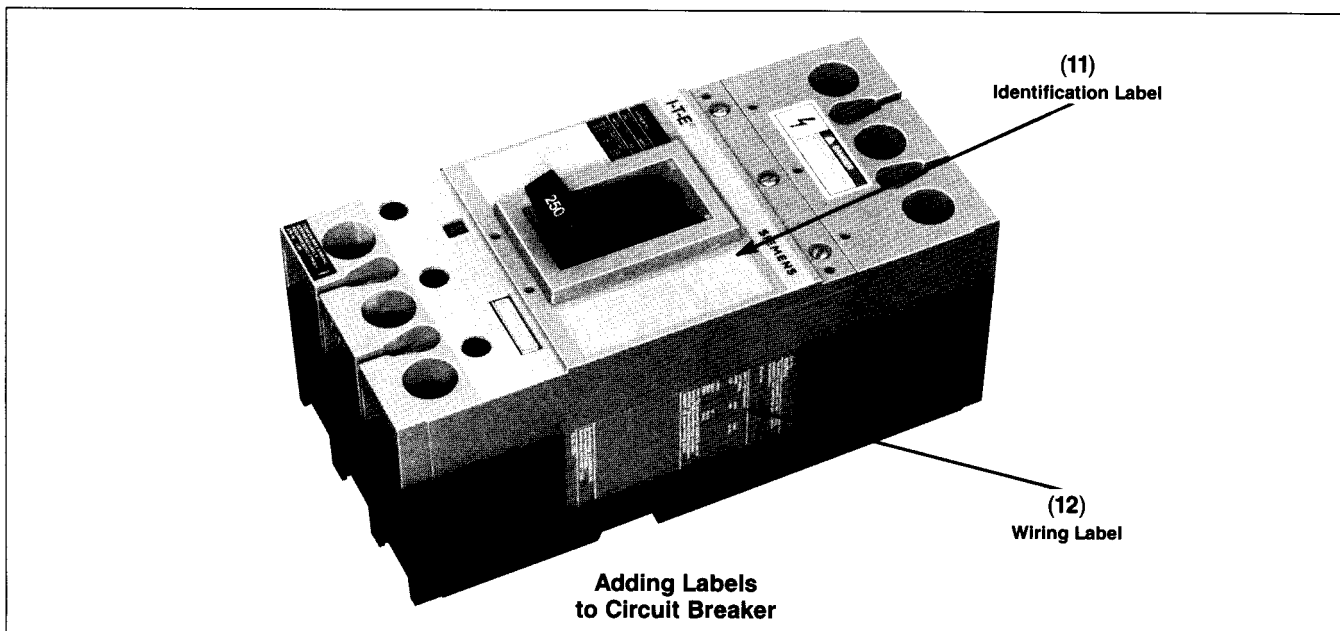

Figure 5

I-T-E Shunt Trip and Undervoltage Trip

Electrical Check

Shunt Trip

- Reset and turn circuit breaker ON.
- Attach test circuit to accessory leads. When the test voltage reaches 55 percent or more of the rated coil voltage, the circuit breaker should trip.
- With breaker TRIPPED or OFF, check to make sure coil circuit has opened.

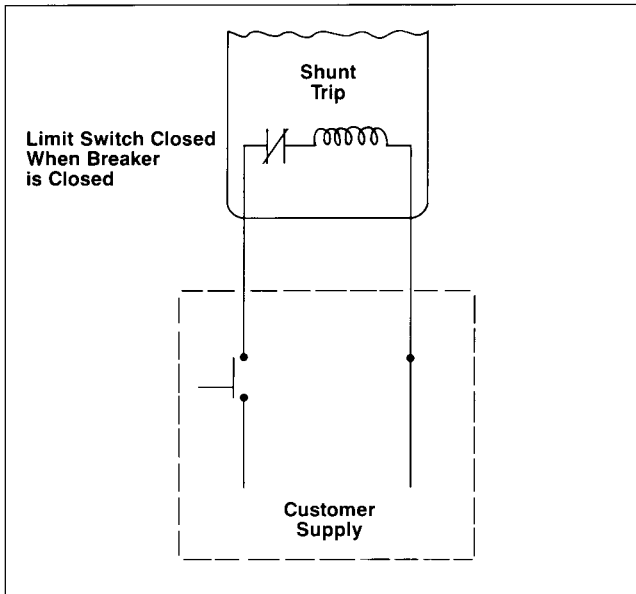

Undervoltage Trip

- With breaker in TRIPPED position, connect test circuit to accessory leads. Energize undervoltage trip device at 85 percent of the marked rated voltage of the coil. Reset and turn breaker handle ON.
- Reduce voltage to 35 percent of rated coil voltage. Circuit breaker must trip. (Undervoltage device must trip between 70 and 35 percent of rated voltage.)

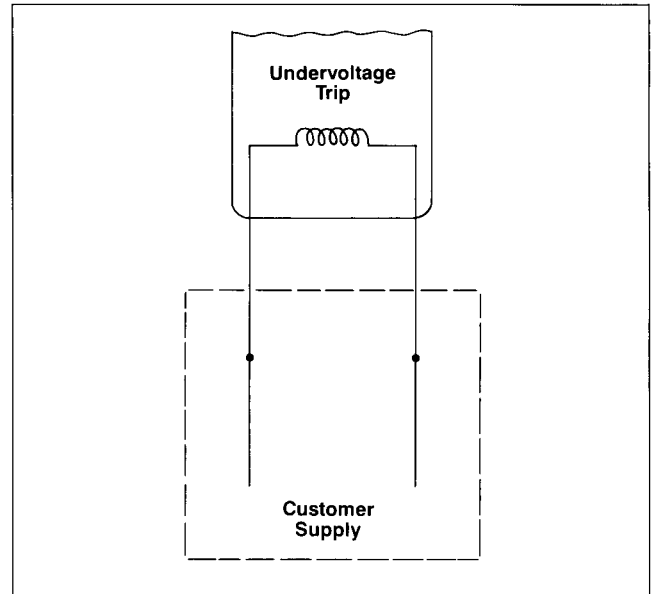

Electrical Data For Shunt Trip

Coil Voltage	Inrush Current At Rated Voltage (Amperes)		Catalog Number
	UL (60 Hz)	IEC 947-2 (50 Hz)	
60 Cycles AC			
12	3.9	4.6	S19FD60
24	1.2	2.0	S17FD60
48	.8	1.0	S18FD60
120	0.395	.462/.577	S01FD60
208	0.265	—	S02FD60
240	0.165	.206/.237	S03FD60
277	0.190	—	S15FD60
480	0.145	.123/.187	S04FD60
600	0.080	—	S06FD60
DC			
12	—	4.3	S16FD60
24	2.2	2.2	S07FD60
48	1.2	1.2	S09FD60
125	0.5	.57/.66	S11FD60
250	0.35	.39/.45	S13FD60

Electrical Data For Undervoltage (UV) Trip^{①②}

Coil Voltage	Sealed-In Current At Rated Voltage (Amperes)	Catalog Number	
		1 UV Trip Plus 1 Aux. Sw.	1 UV Trip Only
60 Cycles AC			
120	.03	W01FD64	U01FD60
208	.018	W02FD64	U02FD60
240	.016	W03FD64	U03FD60
277	.013	W16FD64	U16FD60
480	.008	W06FD64	U06FD60
600 ^③	.008	W08FD64	U08FD60
DC			
24	.11	W13FD64	U13FD60
48	.06	W14FD64	U14FD60
125	.027	W10FD64	U10FD60
250 ^④	.02	W12FD64	U12FD60

① Resistor to be mounted externally and connected by installer in series with undervoltage supply circuit.

② All auxiliary switch ratings are the same as auxiliary switch kit A01FD64.

③ Kit includes a 30k ohm, 25 watt resistor (Clarostat Cat. No. VP-25-K or equivalent).

④ Kit includes a 2.5k ohm, 25 watt resistor (Clarostat Cat. No. VP-25-K or equivalent).

I-E Auxiliary Switch and Bell Alarm

Electrical Check

Auxiliary Switch Kits

Catalog Number	Number of Switches	Ampere Rating of Switch				
		Volts AC			Volts DC	
		120	240	480	125	250
A01FD62	1	7.2	7.2	—	0.5	0.25
A02FD62	2	7.2	7.2	—	0.5	0.25
A01FD64	1	7.2	7.2	7.2	0.5	0.25
A02FD64	2	7.2	7.2	7.2	0.5	0.25

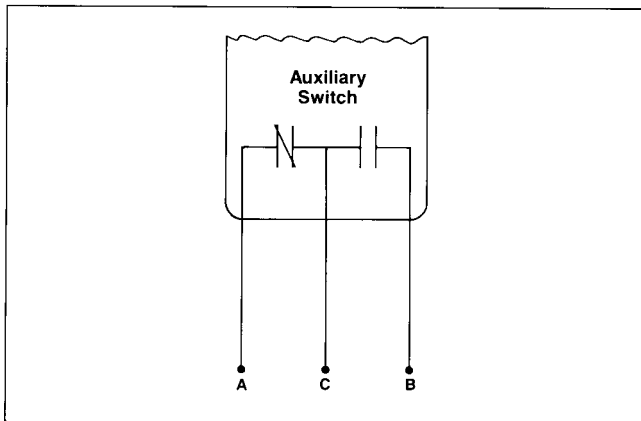

Switch Identification (All With Three Leads)

Wire Markings	Wire Color	Switch Terminals or Contacts
C or C1	White	C - Common terminal
A or A1	Black	N.O. - Contact open when breaker is open, closed when breaker is closed.
B or B1	Red	N.C. - Contact closed when breaker is open, open when breaker is closed.

Accessory units that employ a combination will have the same wiring colors or identifiers. A double auxiliary switch combination will use wiring markings A-A1, B-B1 and C-C1.

Auxiliary Switch ①

- A. Use a buzzer or light indicator attached to switch leads A and C. With breaker in ON position, indicator light or buzzer should operate.
- B. Move handle to OFF position. Indicator light or buzzer should turn off.
- C. Attach test to leads B and C. Light or buzzer should turn on.
- D. Repeat steps A through C using leads A1, B1 and C1.
- E. Move handle to ON position. Indicator light or buzzer should turn off.

① Should the indicator not function properly during "check" procedure, check for incorrect installation or wiring.

Bell Alarm Switch Kits

Catalog Number	Number Of Auxiliary Switches	Ampere Rating of Switch				
		Volts AC			Volts DC	
		125	250	480	125	250
B00FD64	0	7.2	7.2	7.2	0.50	0.25
C01FD64	1	7.2	7.2	7.2	0.50	0.25

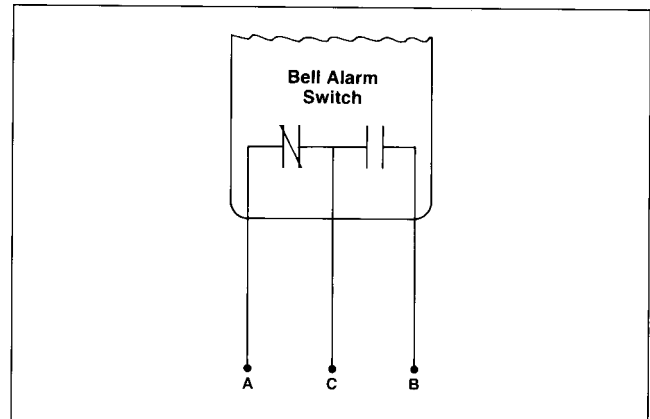

Bell Alarm Identification (All With Three Leads)

Wire Markings	Wire Color	Switch Terminals or Contacts
C	White	C - Common terminal
A	Yellow	N.C. - Normally closed contact (Closed when circuit breaker is tripped.)
B	Brown	N.O. - Normally open contact (Open when circuit breaker is tripped.)

Bell Alarm Switch ①

- A. Use a buzzer or light indicator attached to switch leads A and C. With breaker in ON position, trip breaker by depressing red PUSH TO TRIP button. Indicator light or buzzer should operate.
- B. Reset breaker to OFF. Indicator light or buzzer should turn off.
- C. Move breaker handle to ON. Indicator light or buzzer should remain off.

I-T-E Rotary Handle Enclosure Mechanism

Types 1, 12

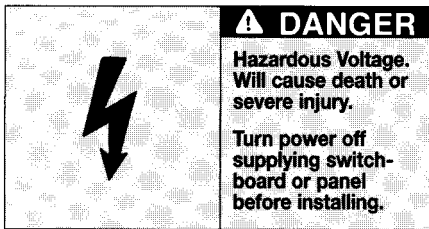

⚠ SAFETY INSTRUCTIONS

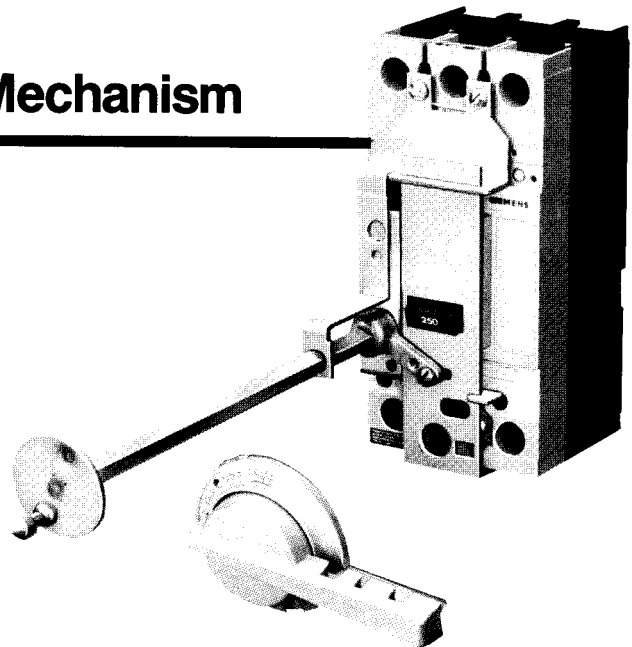

Standard Depth (D11CFU1) Variable Depth (D11CFU2)

General

Handle will permit locking the disconnect device in the OFF position using up to three locks having shackles up to $\frac{3}{8}$ in. in dia. Provision for locking in ON position is provided, but the handle plate must have the material covering the locking notch removed. This can be done with a hacksaw or file. The handle has a voidable interlock. Voiding the interlock requires inserting a small screwdriver into the rectangular opening in the handle plate, which will release the handle.

Mounting Instructions

- A. Drill and tap breaker mounting holes as shown in Figure 1.
- B. Measure distances **A** and **B** from mounting holes to walls of the enclosure (Figure 2).
- C. Find handle center dimensions **D** and **E** by adding enclosure thickness and cover overhang (**C₁** and **C₂**) to **A** - $\frac{11}{16}$ and **B** + $\frac{5}{16}$. Drill hole **X** ($2\frac{1}{4}$ in. dia.) and drill either holes **Y** or **Z** ($\frac{5}{16}$ in. dia.) depending on handle orientation required (Figure 2a).
- D. If installing variable depth kit, measure distance **F** from breaker mounting surface to outside of cover (Figure 3). If distance **F** is less than 8 in., remove shaft guide bracket.
- E. Find length **G** by subtracting **F** from $16\frac{5}{8}$ in. Mark length **G** from end of operating shaft and cut shaft squarely at mark (Figure 3a).
- F. Breaker must be "tripped" during installation. Push red button marked PUSH TO TRIP.
- G. Using screws supplied with kit, attach mechanism plate to breaker and mount in enclosure in position shown.
- H. Insert end of operating shaft into square socket in cast operating arm so that top of shaft has proper relationship to handle. Tighten set screw in operating arm (recommended torque: 75 in. lb.)
- I. Place handle and cork gasket on outside of cover and place handle mounting bracket on inside of cover; fasten together loosely through cover with the two short screws provided.
- J. Adjust handle so that cover will not open when handle is in OFF position but will open when handle is between OFF and RESET/OPEN positions. Tighten screws and operate handle ON and OFF to see that circuit breaker operates satisfactorily.

Installation Diagrams

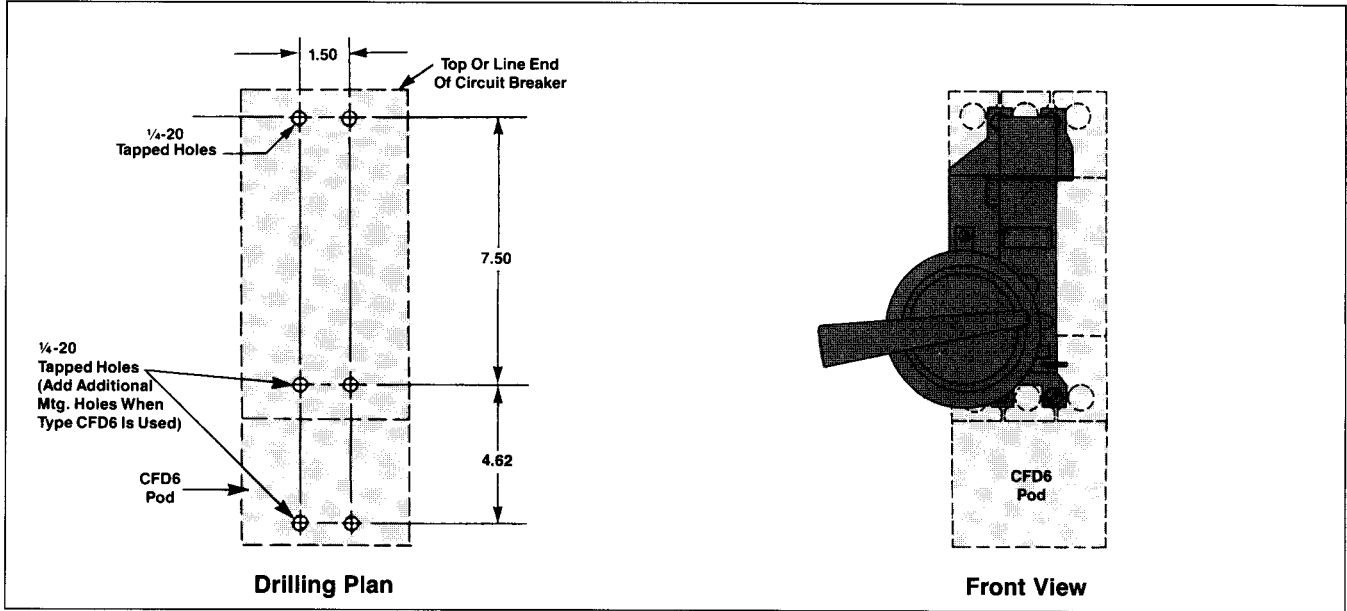

Figure 1

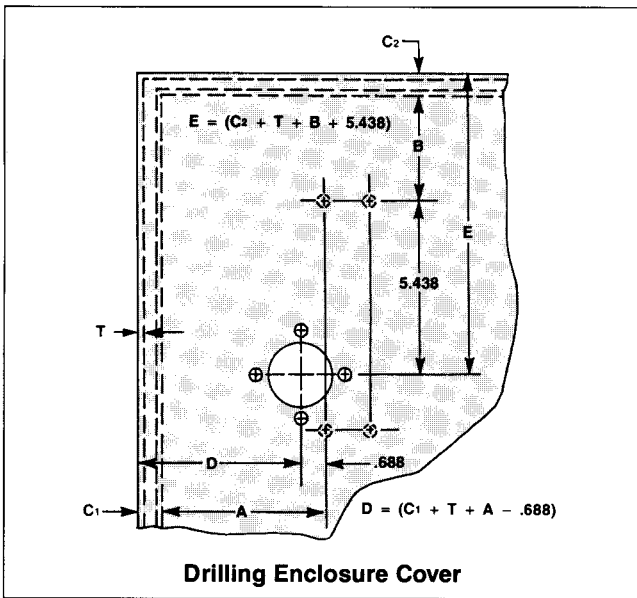

Figure 2

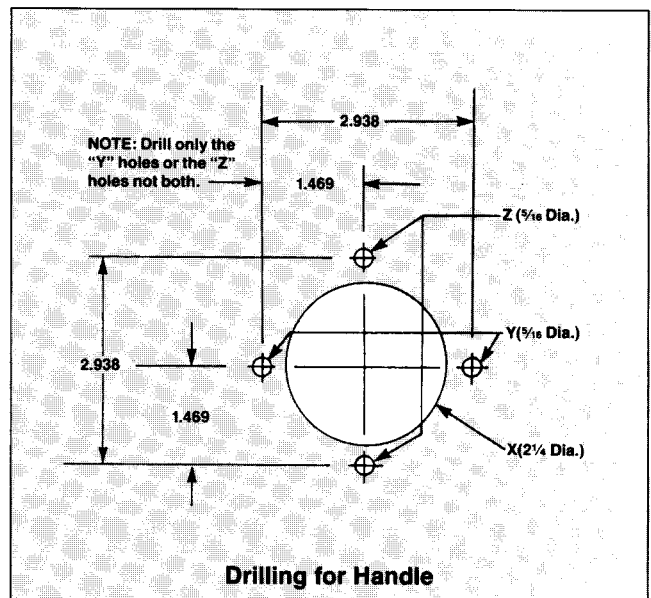

Figure 2a

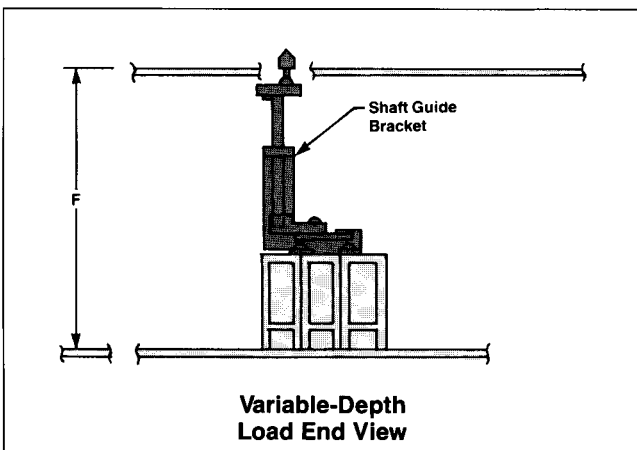

Figure 3

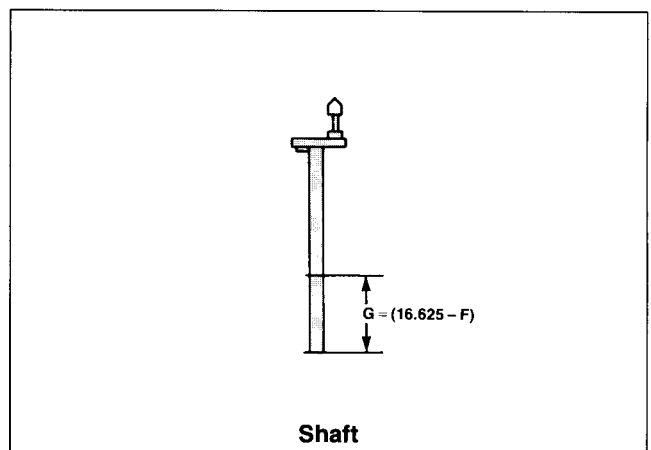
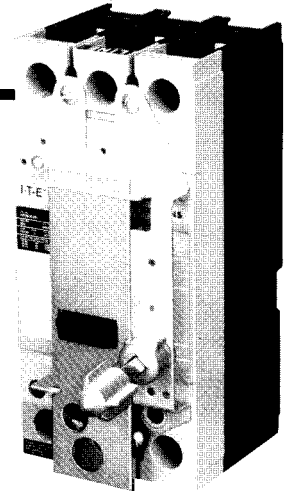
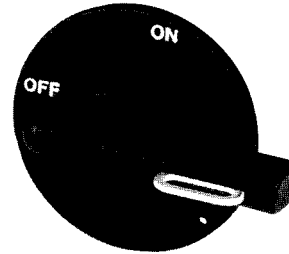
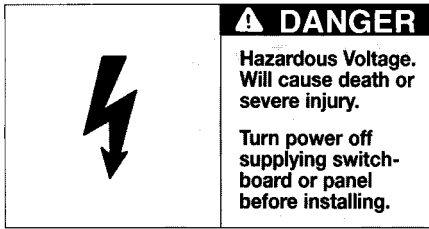

Figure 3a

I-T-E Rotary Handle Enclosure Mechanism

Types 1, 12



SAFETY INSTRUCTIONS

Standard Depth (CRHOFSD) Variable Depth (CRHOFVD)

General Information

When properly installed, the rotary handle operator provides single point latching of the enclosure door. For maximum protection against unauthorized entry into the enclosure, additional latching means should be provided. The handle can be padlocked in the OFF position with up to three 5/16 in. padlocks. The breaker operator can also be padlocked in the OFF position.

Drilling of Enclosure

- A. Catalog number RHOSSD standard depth shafts are used for minimum depth enclosures. Refer to minimum dimension **K** in Figure 2. Catalog Number RHOSVD variable depth shafts are used for all other enclosure depths. Shafts are cut to length **L** as shown in Figure 3.
- B. Drill and tap circuit breaker mounting holes in breaker mounting surface (1) and handle mounting holes in enclosure door (2) as shown in Figure 1.

Installation of Breaker and Breaker Operator (RHOFBO)

- A. Attach the circuit breaker (3) and breaker operator (4) to the enclosure panel using the four mounting screws and lockwashers (5) as shown in Figure 3. Tighten to 75 in. lb.

Installation of Shaft (RHOSSD, RHOSVD)

- A. Shaft length for Variable Depth Operators $L = K - 3.77$ in. Attach the shaft (6) to the operating arm (7) of the breaker operator and tighten the set screw to 70 in. lb. min.

NOTE: The proper orientation of the "wings" (8) (shown in off position) at the end of the shaft when the breaker is in the OFF position (Figure 4).

NOTE: It is recommended that the shaft support bracket (9) be installed if the enclosure depth exceeds 10 in. Attach as shown in Figure 3. Tighten screw to 45 in. lb.

NOTE: RHOSSD Shaft is 2.93" Long
RHOSVD Shaft is 13.25" Long

Installation of Handle (CRHOH)

- A. Attach the handle (10) and gasket (11) to the enclosure door (12) and secure with four bolts, flatwashers, lockwashers and nuts supplied (14). Tighten nuts to 75 in. lb. (Figure 5).
- B. When the enclosure door is closed, check if the handle interlocks with the shaft in all handle positions except RESET/OPEN. To open the enclosure door when the breaker is in the ON position rotate the screw slot on the handle plate counter-clockwise. This procedure will defeat the interlock.
- C. To lock handle in OFF position, pull the lockplate (15) from the handle and insert up to three 5/16 inch padlocks.

Installation Diagrams

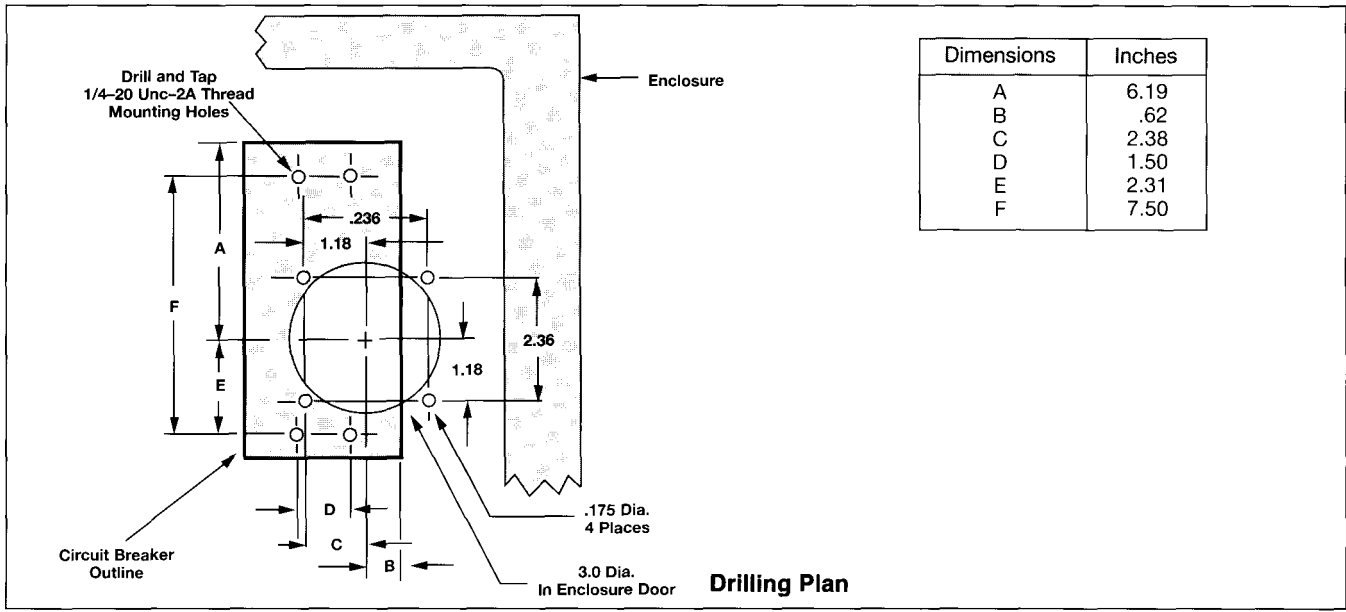

Figure 1

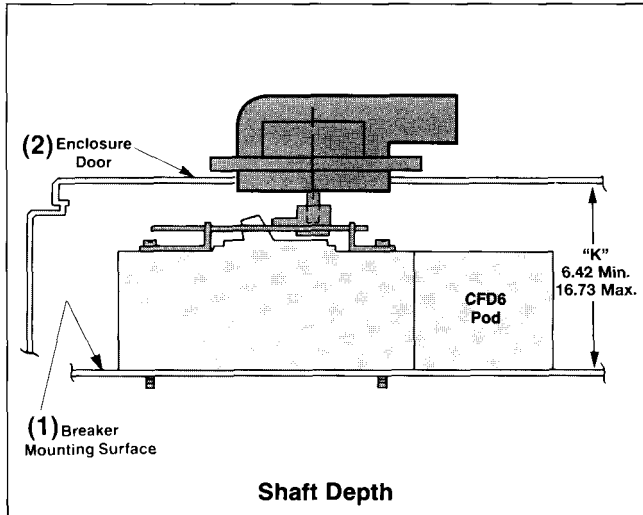

Figure 2

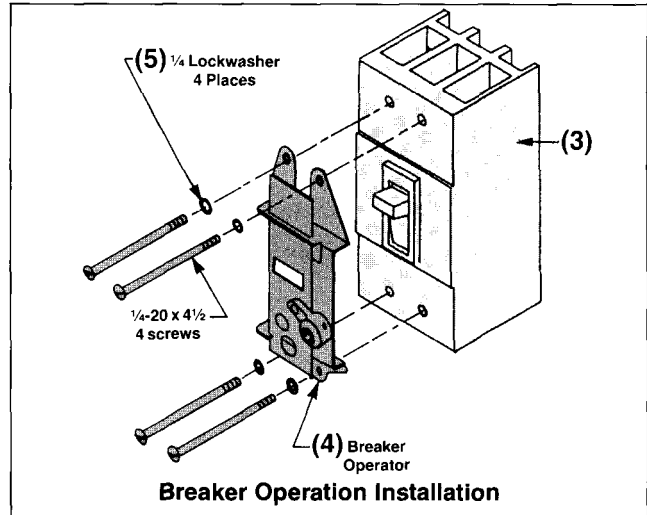

Figure 3

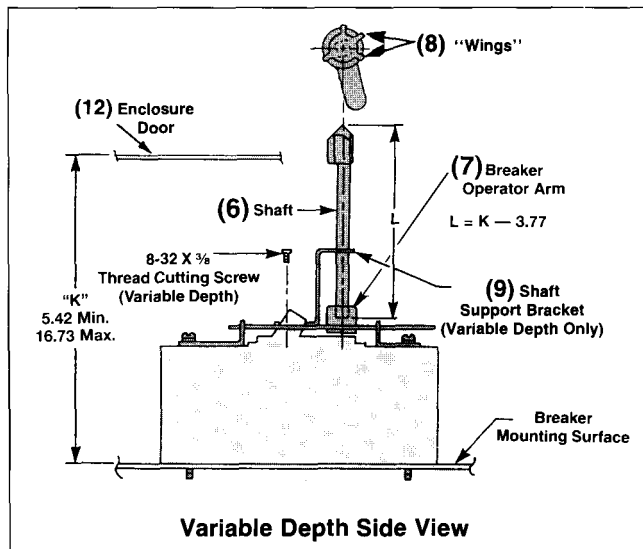

Figure 4

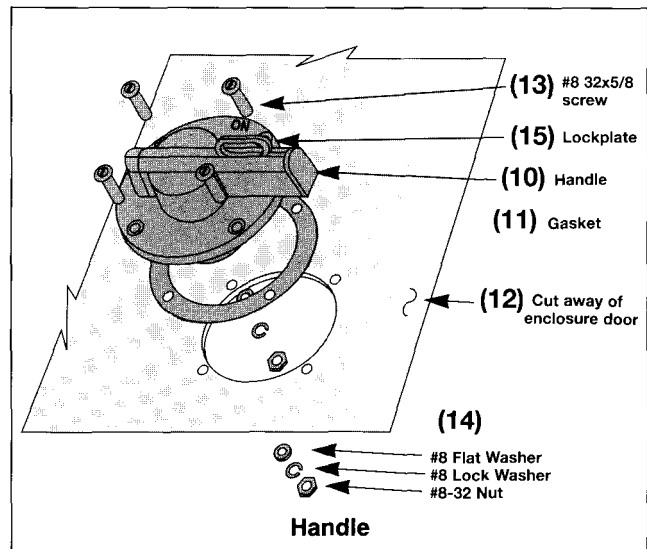
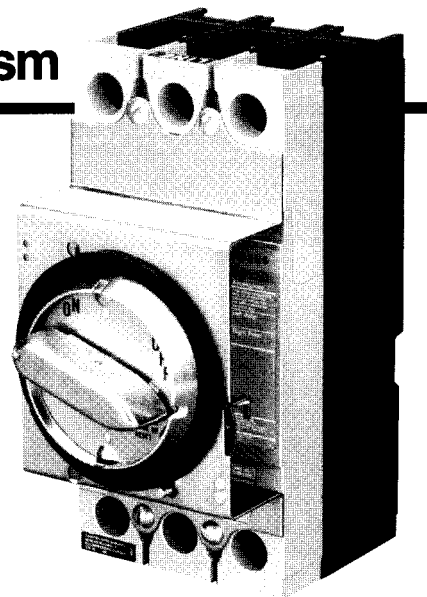
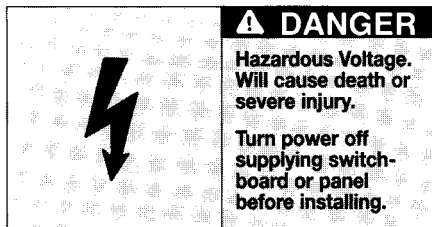

Figure 5

I-T-E Rotary Handle Enclosure Mechanism

Types 1, 12



⚠ SAFETY INSTRUCTIONS

Standard Depth (F6RH1)

Drilling of Enclosure

- A. Drill breaker mounting holes **H** (1) in the enclosure per drilling plan on outline drawing (Figure 1).
- B. Place template on breaker mounting surface so that the four centers in the template line up with the breaker mounting holes. Make sure ON-OFF indications on template are in same direction as ON-OFF indications on the breaker. To hold template in place, punch two holes in template with breaker mounting screws and tighten into breaker mounting holes.
- C. Measure distances **N** and **P** from walls of enclosure (Figure 2).
- D. Relocate template on enclosure cover by adding enclosure thickness and cover overhang **R** to dimensions **N** and **P** (Figure 3).
- E. Remove backing from template and secure template on door.
- F. Drill holes **J** ($\frac{3}{8}$ in. dia.) and **K** ($\frac{4}{8}$ in. dia.) on template (Figure 3).

Circuit Breaker/Rotary Handle Mechanism Mounting

- A. Mount breaker with handle up by sliding it under the tabs in the mounting plate.
- B. With breaker in OFF position and rotary handle mechanism in OFF position, mount mechanism on breaker using four $\frac{1}{4}$ -20 x $\frac{1}{4}$ in. screws. Make sure opening in mechanism lever engages breaker handle. Tighten screws.
- C. Loosely secure the door rings with the three #6-32 x $\frac{1}{4}$ in. screws provided. Position the interior ring (2) (contains latch tabs and threaded holes) as shown in Figure 4. The exterior ring mounts on the outside of the door with the small flange to the inside (Figure 5).
- D. Close the enclosure door and adjust external ring on door so it is concentric with handle ring. Tighten the three screws (4).
- E. Check the door operation. Latch on mechanism should engage latch tab (3) interior ring when breaker is ON and disengage latch tab when handle is rotated to OPEN DOOR position. Repeat Step C if a slight adjustment is necessary.
- F. Enclosure door may be opened when breaker is ON by turning defeater screw (5) on rotary handle face plate (Figure 1) in a clockwise direction.

Installation Diagrams

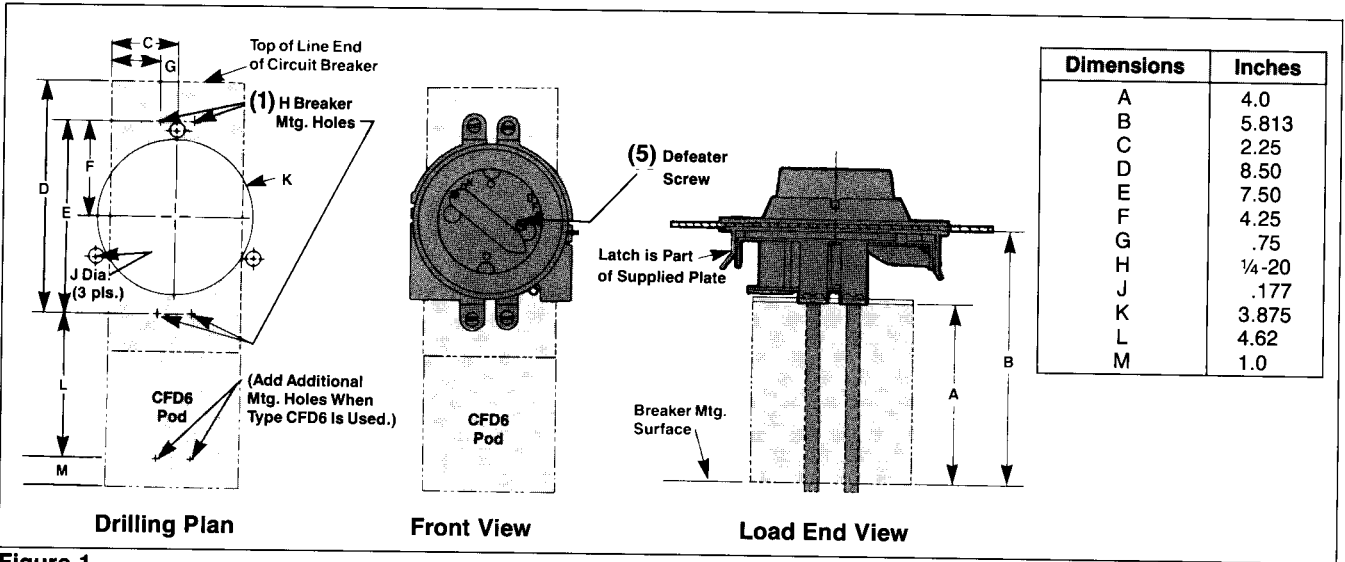

Figure 1

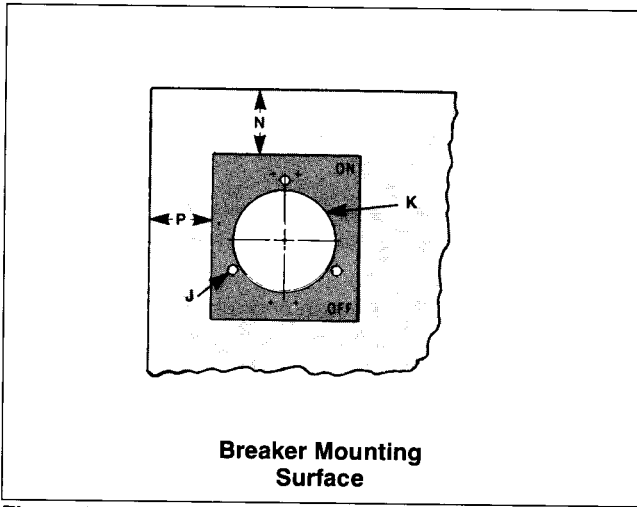

Figure 2

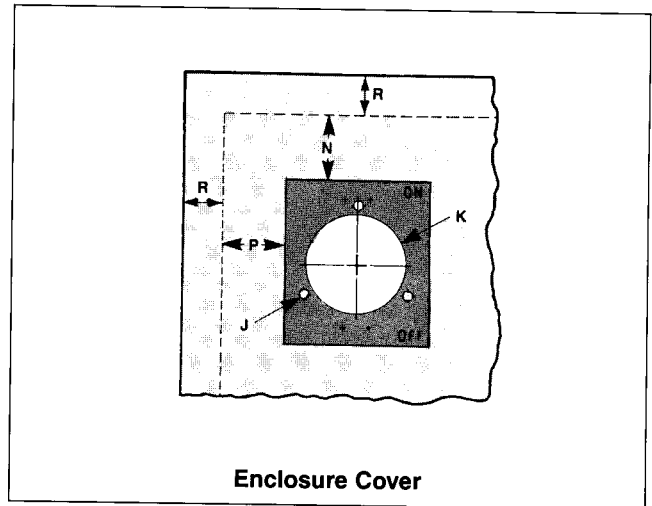

Figure 3

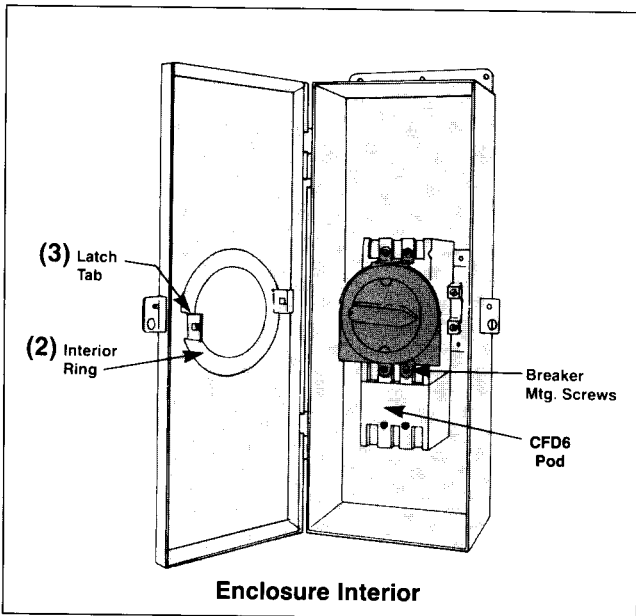

Figure 4

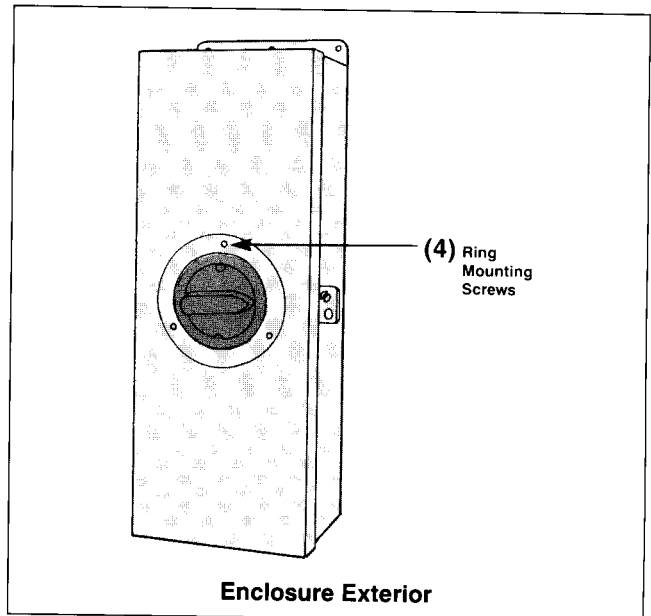
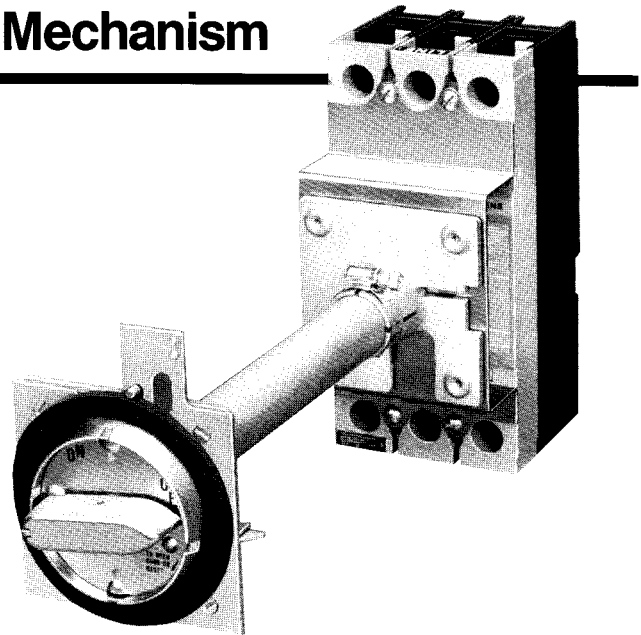
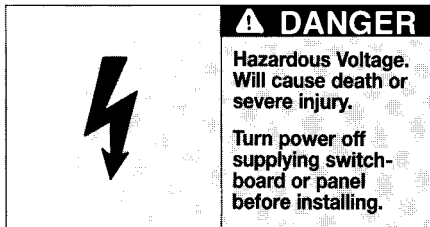

Figure 5

I-T-E Rotary Handle Enclosure Mechanism

Types 1, 12



Variable Depth (F6RHV9)^①

INSTALLATION INSTRUCTIONS

Drilling of Enclosure

- Drill breaker mounting holes **H** (1) in the enclosure per drilling plan on outline drawing (Figure 1).
- Place template on breaker mounting surface so that the four centers in the template line up with the breaker mounting holes. Make sure ON-OFF indications on template are in same direction as ON-OFF indications on the breaker. To hold template in place, punch two holes in template with breaker mounting screws and tighten into breaker mounting holes.
- Measure distances **N** and **P** from walls of enclosure (Figure 2).
- Relocate template on enclosure cover by adding enclosure thickness and cover overhang **R** to dimensions **N** and **P** (Figure 3).
- Remove backing from template and secure template on door.
- Drill holes **J** ($\frac{3}{8}$ in. dia.) and **K** ($\frac{4}{8}$ in. dia.) on template (Figure 3).

Circuit Breaker/Rotary Handle Mechanism Mounting

- Mount breaker with handle up by sliding it under the tabs in mounting plate.
- With breaker in OFF position and rotary handle mechanism in OFF position, mount mechanism on breaker using four #1 $\frac{1}{4}$ -20 x 4 $\frac{1}{4}$ in. screws. Make sure opening in mechanism lever engages breaker handle. Tighten screws.
- Loosely secure the door rings with three #6-32 x $\frac{1}{4}$ in. screws as provided. Position the interior ring (2) (contains latch tabs and threaded holes) as shown in Figure 4. The exterior ring mounts on the outside (Figure 5).
- Close the enclosure door and adjust external ring on door so it is concentric with handle ring. Tighten the three screws (4).
- Check the door operation. Latch on mechanism should engage latch tab (3) interior ring when breaker is ON and disengage latch tab when handle is rotated to OPEN DOOR position.
- Enclosure door may be opened when breaker is ON by turning defeater screw (5) on rotary handle face plate in a clockwise direction.

^①Supplied with 9 in. long extension.

Installation Diagrams

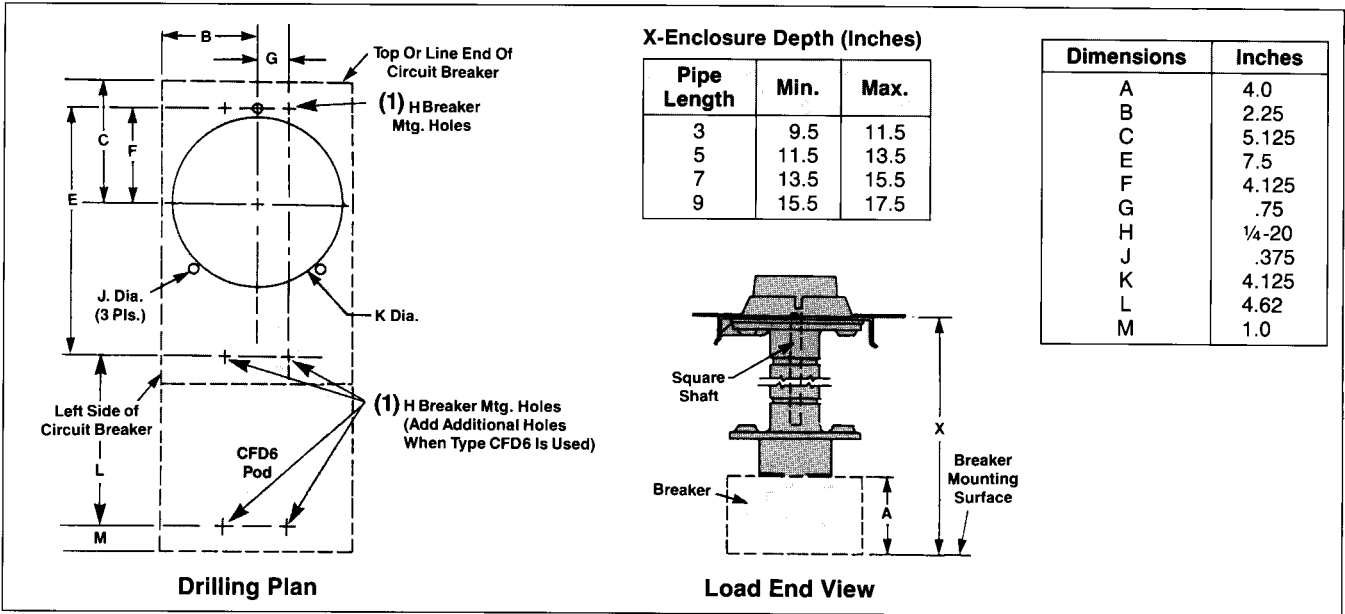

Figure 1

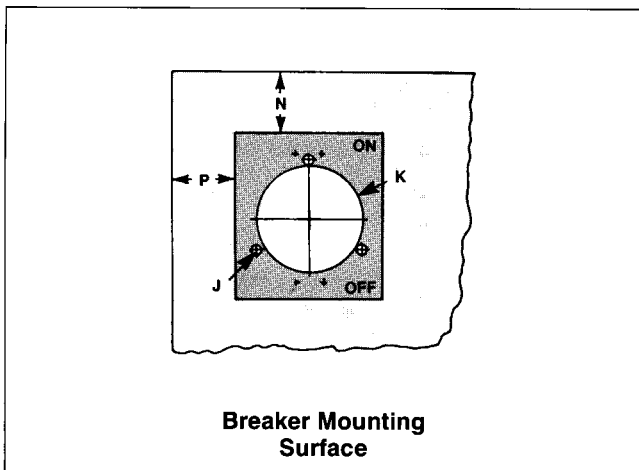

Figure 2

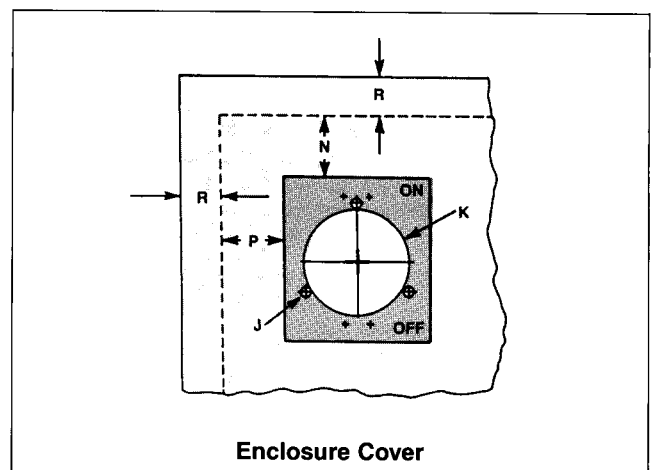

Figure 3

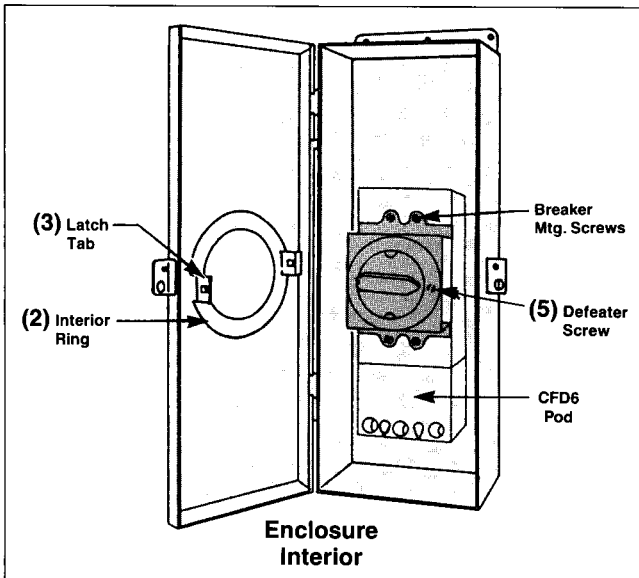

Figure 4

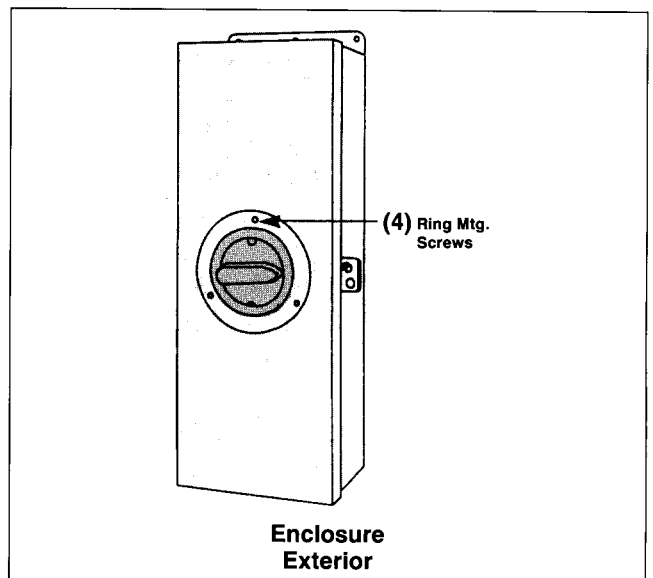
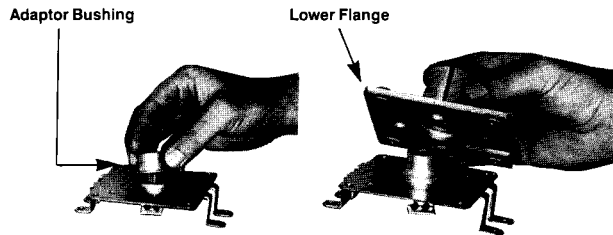

Figure 5

I-T-E Rotary Handle Enclosure Mechanism

Types 1, 12 — Mechanical Assembly

Variable-Depth (F6RHV9)①



Mechanical Assembly

A. With adapter bushing in place on bearing of lower mechanism, place lower flange (flange with the four tapped holes) on to the lower mechanism. Secure with four flat head screws.

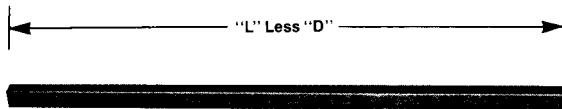

C. Cut square shaft to desired dimension. To do this subtract dimension **D** (see dimension chart on page 31) from **M** dimension which is the distance from the back of the breaker to inside of enclosure door.

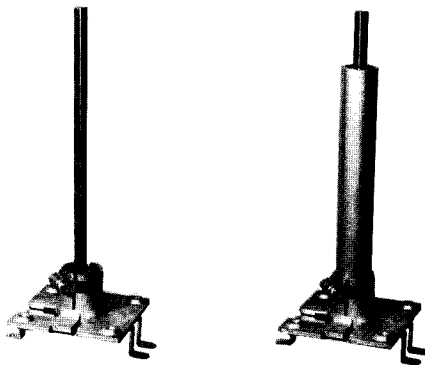

E. Place square shaft into bushing on lower mechanism and then place support pipe over this shaft and into collar or flange.

G. Lay assembly on flat surface (this will square assembly). If **M** dimension is the minimum, as shown on dimensional chart, tighten pipe clamps with support pipe seated fully into both flange collars. If **M** dimension is other than minimum, adjust support pipe so that approximately the same amount of pipe is in each of the upper and lower flange collars. (A minimum of 1/2 in. pipe must be in each flange collar.) Tighten pipe clamps.

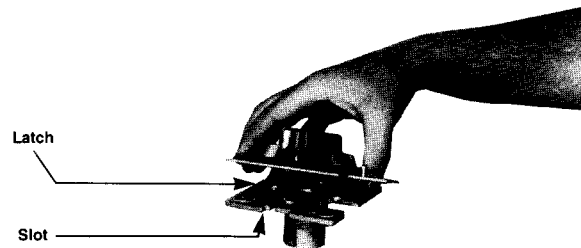

B. Place upper mechanism on upper flange (flange with four tapped holes) and secure with four flat head screws. Be sure latch on mechanism fits into elongated slot in flange.

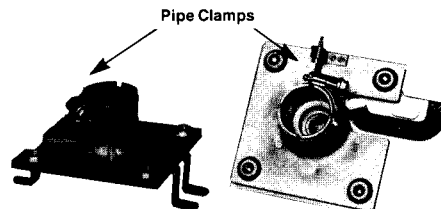

D. Place pipe clamp on the collar of each flange. Do not tighten.

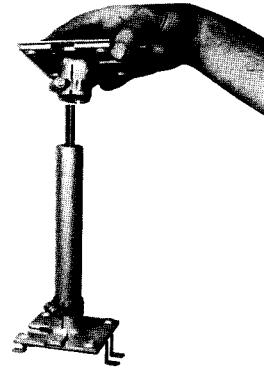

F. With both lower and upper mechanisms in OFF position (lower mechanism is OFF when square shaft is turned fully to the right) place upper mechanism on to support pipe. Make sure square shaft engages upper mechanism.

① Supplied with 9 in. long extension.

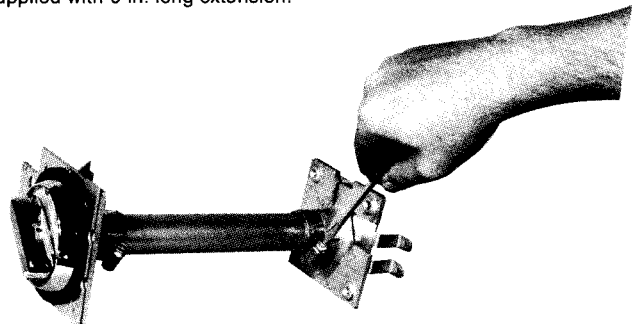

I-T-E Max-Flex™ Flange-Mount Handle Operator

Types 1, 3, 3R, 4, 4X, 12

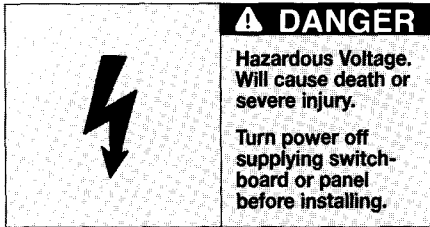

⚠ SAFETY INSTRUCTIONS

GENERAL INFORMATION

Description

The I-T-E Max-Flex™ Flange-Mount Handle Operator is a flexible cable control device used for the remote switching of a circuit breaker within an enclosure. The flexible cable is connected directly to the breaker switch handle at one end and a factory installed switch handle operator at the other end. The remote operator handle, located on the enclosure flange, is used to perform mechanical open/close switching operations. This is accomplished through the cable's sliding center race enclosed within the cable.

Function

The advanced design concept of the Max-Flex Handle Operator provides for greater flexibility when locating a circuit breaker within an enclosure. The circuit breaker can be mounted almost anywhere, at any angle and on almost any convenient surface. The same flexibility applies when locating the switch handle operator on the flange section of the enclosure.

Application

The Max-Flex Operator is designed to work with I-T-E circuit breakers having current ratings through 1200A. The Max-Flex unit meets all the industrial criteria such as UL and Automotive Industry Standards.

Design

The new Max-Flex Handle Operator provides maximum flexibility in design and assembly of electrical equipment. Since there are no linkages to assemble, the Max-Flex system can save time during installation.

The cable design is flexible and rugged. It is similar to those cables used in aircraft control systems. The flexible cable comes in standard 3 or 4 ft. lengths. However, specific lengths can be special ordered up to 20 ft.

Operation

When properly installed, the Max-Flex Handle Operator is used to perform remote switching operations from outside of the enclosure. Switching is accomplished by pushing the Max-Flex Handle Operator up for ON and down for OFF. The mechanical advantage gained with this device simplifies switching operations when compared with local switching at the breaker.

This unique design offers breaker trip indication as a standard feature. Interlocking provisions are included and described below. All switching functions are standard to accepted practices.

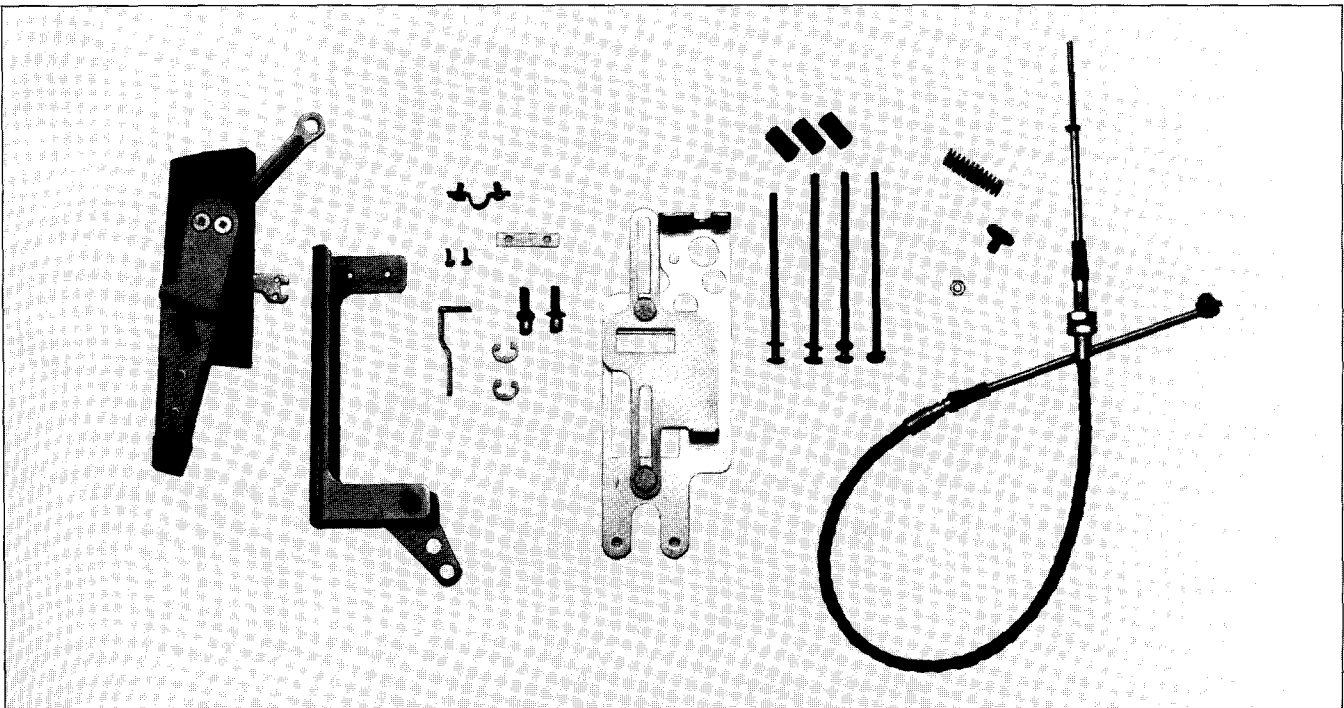

Unassembled Max-Flex™ Flange-Mount-Handle Operator

I-T-E Max-Flex™ Flange-Mount Handle Operator

Types 1, 3, 3R, 4, 4X, 12

INSTALLATION

Mounting Max-Flex™ Handle Operator to Enclosure Frame Assembly

- Drill the mounting holes in the enclosure flange and file all burrs (Figures 1 and 2). Note the maximum and minimum drill hole distances in Figure 2.
- Push the rubber gasket (1) down in the groove of the handle assembly (2) (Figure 3).
- The handle and the interlock mechanism are supplied pre-assembled from the factory. **NOTE:** For ease of assembly, move the operating handle to the ON position. (up toward the top of the enclosure). Mount the frame (4) and handle assembly (2) to the enclosure flange (5) with two #1/4-20 x 3/4 in. socket head cap screws and lockwashers. Tighten cap screws from within the enclosure (Figure 3).

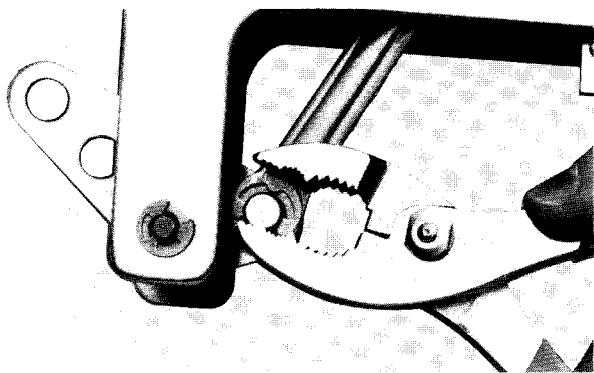

Secure E-Ring Connection

- Rotate the bellcrank (6) clockwise to engage the return spring (7). Hold the bellcrank in position and place the plastic washer (8) and connecting link (9) onto the bellcrank pin (10). Using pliers, secure the connection with an E-ring (11) (Figure 3).
- Mount the interlock lever extension (12) to the interlock lever (3) using #8-32 x 3/8 in. machine screw and lockwasher. Screw mounts through the threaded lever extension into the lever (Figure 3).

Operating Note: With the enclosure door open, the operating handle cannot be moved from the OFF to ON position without deliberately defeating the interlock mechanism. In the OFF position, the interlock can be defeated by pushing the interlock lever extension (12) downward while moving the handle to the ON position (Figure 2). With the enclosure door closed and the handle in the ON position, the interlock can be defeated by turning the defeater screw (13) on the operating handle counter-clockwise on left-hand side and clockwise on right-hand side. When the enclosure door is closed, the door latch mechanism now automatically defeats the interlock.

- Weld the door catch bracket (14) to the enclosure door. (Figures 2 and 4).

NOTE: Holes may be drilled in the door catch bracket using the projections as centers. *User must provide the mounting hardware.*

- Fasten the door catch (15) to the door catch bracket with two #8-32 x 5/16 in. pan head screws and external tooth lockwashers (Figure 2).

INSTALLATION DIAGRAMS

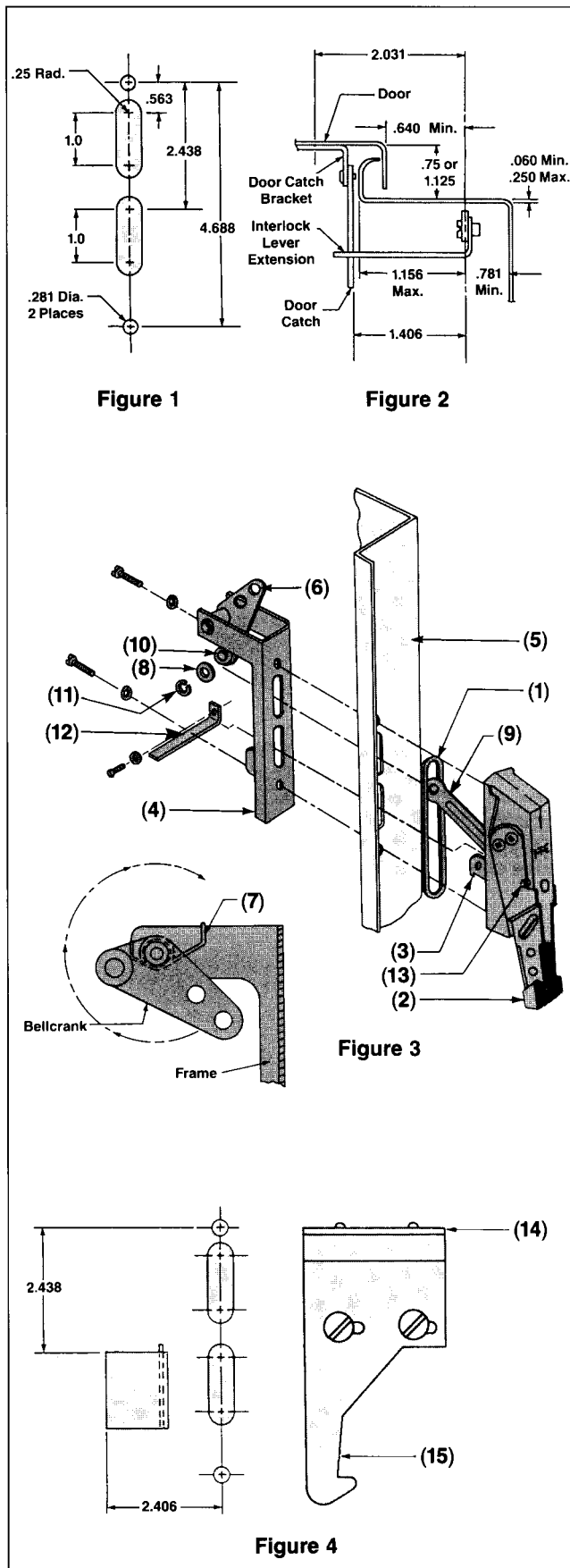

Assembly Instructions

Adjusting Door Catch Mechanism

- Close the enclosure door and move the handle into the ON position. Adjust the door catch downward if the handle cannot be moved from the ON position.
- With the handle in the ON position, try to open the enclosure door without turning the defeater screw in the handle. If the door opens, readjust the door catch and repeat Steps A and B.

Mounting Breaker Operator

The circuit breaker can be mounted remotely from the handle within a range that is limited by the length of the operating cable (16) and the depth of the enclosure. Table 2 and Figure 5 show the horizontal range E of the circuit breaker in 8 to 30 in. enclosures.

Table 1 — Circuit Breaker Mounting Dimensions

Frame	A	B	C	D	G	Tap Size
CFD6, CFD6-ETI	1.5	7.5	1.0	14.13	4.62	#1/4-20
All Other Types	1.5	7.5	1.0	9.5	—	#1/4-20

Table 2 — Maximum E Dimensions ①

Cable	Enclosure Depth							
	8"	10"	12"	16"	18"	20"	24"	30"
FHOFCO36 (36 in.)	11.2	11.0	10.5	8.3	6.5	3.5	—	—
FHOFCO48 (48 in.)	23.2	23.0	22.8	21.7	21.0	20.0	17.3	10.2

① Maximum E dimension only if F = 4.6.

Table 3 — F Dimensions

Enclosure Depth	36" Cable		48" Cable	
	Min.	Max.	Min.	Max.
8	-4.2	15.5	-16.0	27.0
10	-5.2	15.0	-16.5	27.0
12	-6.0	14.7	-17.0	26.8
16	-4.5	14.2	-16.5	26.5
18	-3.4	12.8	-16.0	25.5
20	0.6	10.0	-15.5	24.5
24	—	—	-14.0	22.5
30	—	—	-8.7	17.4

NOTE: When installed, the cable bend radius should not be less than 3 in. This minimum wire bending requirement must be met to insure operating safety. The mounting procedure is as follows:

- Determine the desired circuit breaker mounting location using Tables 1, 2 and Figure 5.
- Drill and tap four mounting holes (17) in the enclosure back panel using dimensions A and B from Table 1.
- Mount the circuit breaker inside the back panel. Align the holes in the panel with the mounting holes of the breaker.
- Insert the three plastic spacers (18) into the circuit breaker mounting holes for support, as shown in Figure 6.
- Install the operating mechanism (19) on the spacers (18) and secure with the three #1/4-20 x 5 in. pan head screws and lockwashers. Insert the #1/4-20 x 4 1/4 in. pan head screw through the hole without a spacer (20). Mount the circuit breaker and operating mechanism to the enclosure panel with the screws supplied.

Securing Operating Cable to Frame Assembly

- To attach the operating cable (16) to the frame assembly (4), move the operating handle (2) to the ON position and attach the cable swivel (21) to the outer hole of the bellcrank (6). Secure the connection with an E Ring (Figure 7).

INSTALLATION DIAGRAMS

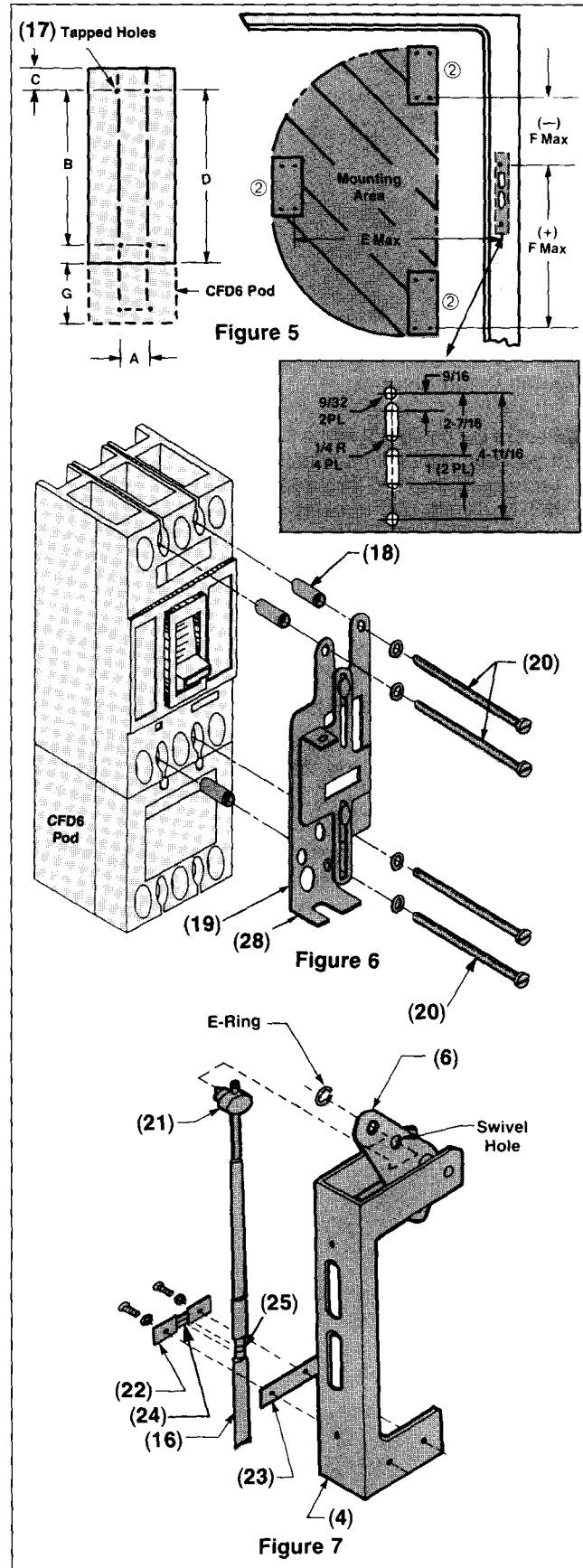

② Outlines represent breaker operator, not circuit breaker footprint.

I-T-E Max-Flex™ Flange-Mount Handle Operator

Types 1, 3, 3R, 4, 4X, 12

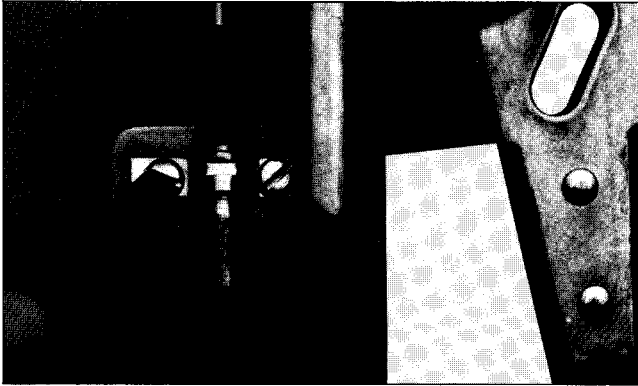

Tighten Detent Screws

- B. Secure the cable (16) to the frame assembly (4) by placing it between the cable retainer clip (22) and the shim (23), secure with two #10-32 x 3/8 in. screws and lockwashers. NOTE: Detent (24) in cable retainer must align with the groove (25) in the cable's metal fitting (Figure 7).

Securing Operating Cable to Circuit Breaker

NOTE: Before attaching the cable to the circuit breaker, installers *must* confirm that the power from the supply source has been de-energized.

- A. Move the circuit breaker handle to the ON position.
- B. Remove the soft plastic cap from the end of the threaded cable rod (26) and slide the rod through the hole in the sliding plate tab (27) of the circuit breaker operating mechanism (19) (Figure 8).
- C. Move the flange mount operating handle (2) to its maximum ON position and hold it in place.
- D. Place the cable mounting threads (26) into the slot on the fixed plate tab (28) so that the two mounting nuts (29) are on both sides of the tab. Adjust the two mounting nuts so that the #10-32 nut on the cable rod just touches the sliding plate tab (27). Tighten the mounting nuts (29) to secure the cable (Figure 8).
- E. Continue holding the operating handle in the ON position and place the spring (30) over the end of the rod. Screw on the spring adjuster (31) and tighten until it begins to compress the spring. Do not overtighten.

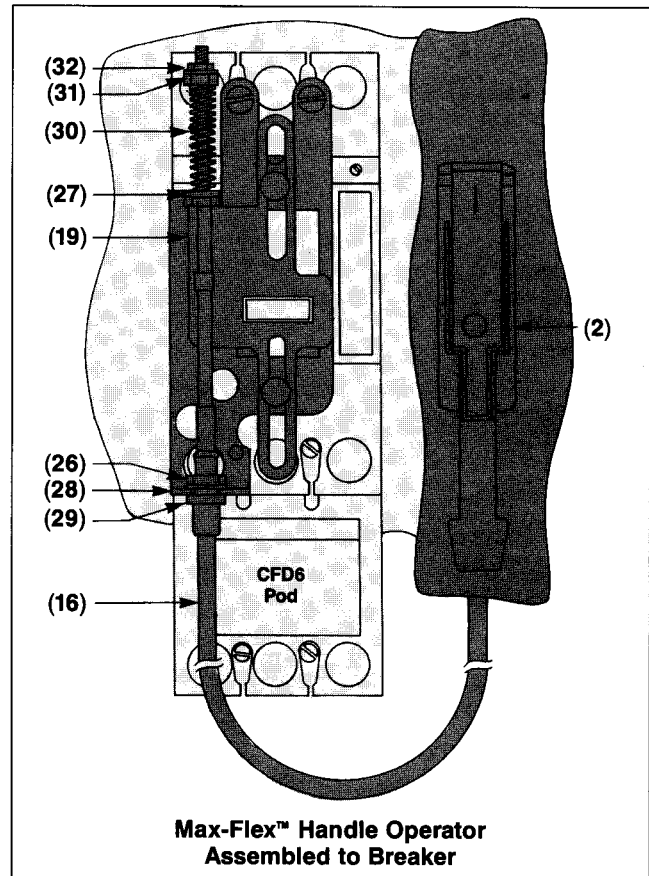
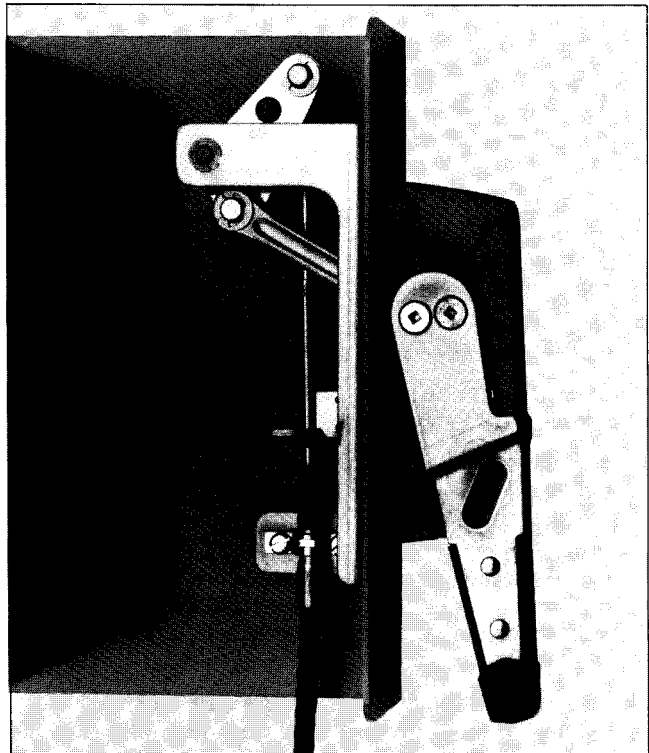

Figure 8



Side View of Max-Flex™ Handle Operator

Assembly Instructions

Making Cable Adjustments

- A. Check that circuit breaker turns OFF and ON by moving the operating handle (2) up for ON and down for OFF. If the breaker does not switch ON, loosen the cable mounting nuts (29) at the fixed plate tab (28), hold the operating handle in the maximum ON position, and move the cable (16) toward the top of the breaker. Retighten the mounting nuts (29) to secure.
- B. Trip the circuit breaker by pressing the PUSH TO TRIP button on the front of the circuit breaker.
- C. Check that circuit breaker resets by moving the operating handle (2) from ON to OFF and back to ON. If the breaker resets, tighten the spring adjuster (31) one additional turn. Attach the lockwasher and #10-32 locknut (32) to the end of the cable rod, and tighten the locknut.
- D. If the circuit breaker does not reset after Step B, tighten the spring adjuster (31) one turn and repeat Step B. Continue this procedure until the breaker does reset, then tighten the adjuster spring one additional turn. Secure with the lockwasher and locknut (32).

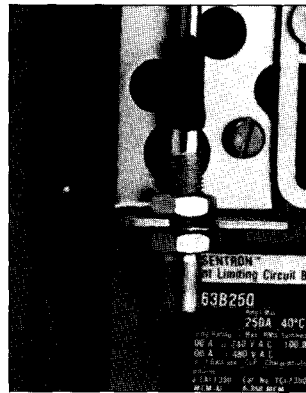

Fixed Plate Adjustment

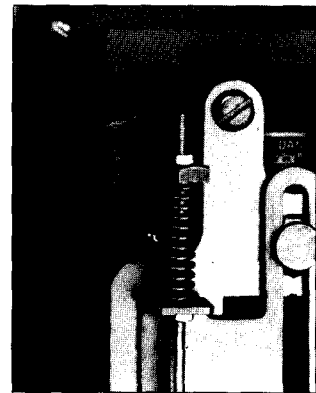

Spring Adjustment

I-T-E Door Latch Mechanism (DKR2, DKR3, DKL2, DKL3)^①

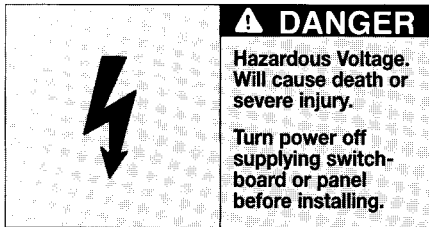

SAFETY INSTRUCTIONS

General Information

These door latch mechanisms are for use in standard or custom built enclosures. The door latch post assemblies and the door catch are supplied with the kits. *Users must supply their own 1/4 in. x 1/2 in. steel latch bar.* Enclosures with an overall height less than 40 in. require the two-point door latch mechanism. When the overall height is greater than 40 in., the three-point latch mechanism is used.

The door latch mechanism can be used with or without the type FHOH Flange Mount Handle Operator. These instructions apply when the door latch mechanism is mounted adjacent to and interlocks with the FHOH Handle Operator. The door handle can be padlocked to prevent unauthorized entry into the enclosure. Drawings in these installation instructions are oriented for right-hand flange installation. Left-hand flange installation drawings are mirror images of the right-hand versions. For left-hand flange installation, substitute "clockwise" for "counterclockwise" and vice versa, whenever those words appear.

Installation of the Door Latch Mechanism

A. Drill mounting holes in the enclosure door observing the minimum dimensions shown in Figure 2. See FHOH Handle Operator instructions for flange drilling pattern.

NOTE: **D** and **E** dimensions are determined by the height of the enclosure.

Refer to Figure 1 for the following steps:

- B. Place gasket (1) on handle plate (2) and attach handle plate to enclosure door with two thin wall hex nuts (3). Tighten the nuts to 100 in. lb.
- C. Insert lockout screw (4) and handle (5) through holes in the handle plate.
- D. Install latch bar post assembly (6) (screw, sealing washer, flat washer, and special hex nut (7), if used.)
- E. Attach top (8), bottom (9) and latch plate rollers (10) to latch bar with retaining pins and E-rings.

NOTE: Two-point latch does not have bottom roller.

- F. Fasten the top and bottom rollers to the enclosure door with locking type flange nuts. Tighten the nuts, then loosen them 1/8 turn to allow movement of the roller assemblies.
- G. Place bottom spring (11) over the bottom thin wall hex nut inside the enclosure door.

- H. Turn the handle 1/4 turn clockwise (looking from inside the enclosure door) and attach the latch plate roller to the handle shaft, while inserting the bent leg of the spring into the hole in the latch plate. Fasten with a locking-type flange nut. Tighten the nut, then loosen 1/8 turn to allow movement of the roller assemblies (Figure 1).

NOTE: Straight leg of spring must rest against pin (12) on handle plate. See inset on Figure 1.

- I. Place top spring (13) over top thin wall hex nut. Attach lockout plate (14) to lockout screw using locking type flange nut. Tighten flange nut. Insert bent leg of spring into hole in lockout plate as shown in Figure 1 detail.
- J. Attach the interlock defeater lever (15) to the latch bar (16) with two #10 lockwashers and #10-24 screws.

NOTE: The position of lever depends on enclosure depth (Figure 3).

- K. Weld or rivet the door catch (17) to the enclosure door. User must supply the mounting hardware.
- L. Attach the door latch label to the door handle on the enclosure door.

Adjusting the Mechanism

If using in conjunction with the FHOH or FHOH4 Handle Operator, perform the following steps:

- A. With the door in the open (unlatched) position, close the door, but do not turn the door handle. The lockout plate should latch the door partially closed.
- B. Turn the handle clockwise to stop. This will engage the rollers against the enclosure flange, securing the door fully closed.
- C. Check that the circuit breaker can be turned ON. If the breaker will not turn ON, adjust the interlock defeater lever downward to engage the lever on the handle operator.
- D. To open the door, insert a screwdriver into the handle screw and turn the screw and handle counterclockwise. The door will only open partially if the operating handle is in the ON position. If the door fully opens with the handle in the ON position, adjust the interlock defeater lever upward and repeat Steps C and D.

NOTE: To open the door when the handle is in the ON position, turn the latch defeater screw located on the side of the operating handle.

Minimum Dimensions (In Inches)

C	1.922	Q	2.594
H	9.375	R	1.875
I	.50	S	1.625
J	2.688	T	.250
K	1.859	U	.688
L	1.797	V	.281 Dia.
M	.391 Dia.	W	.703 Dia.
N	2.297	X	2.484
P	.719	Y	.219 Dia.

① The last letter and number designate right- or left-hand, 2 or 3 point latches.

Installation Diagram

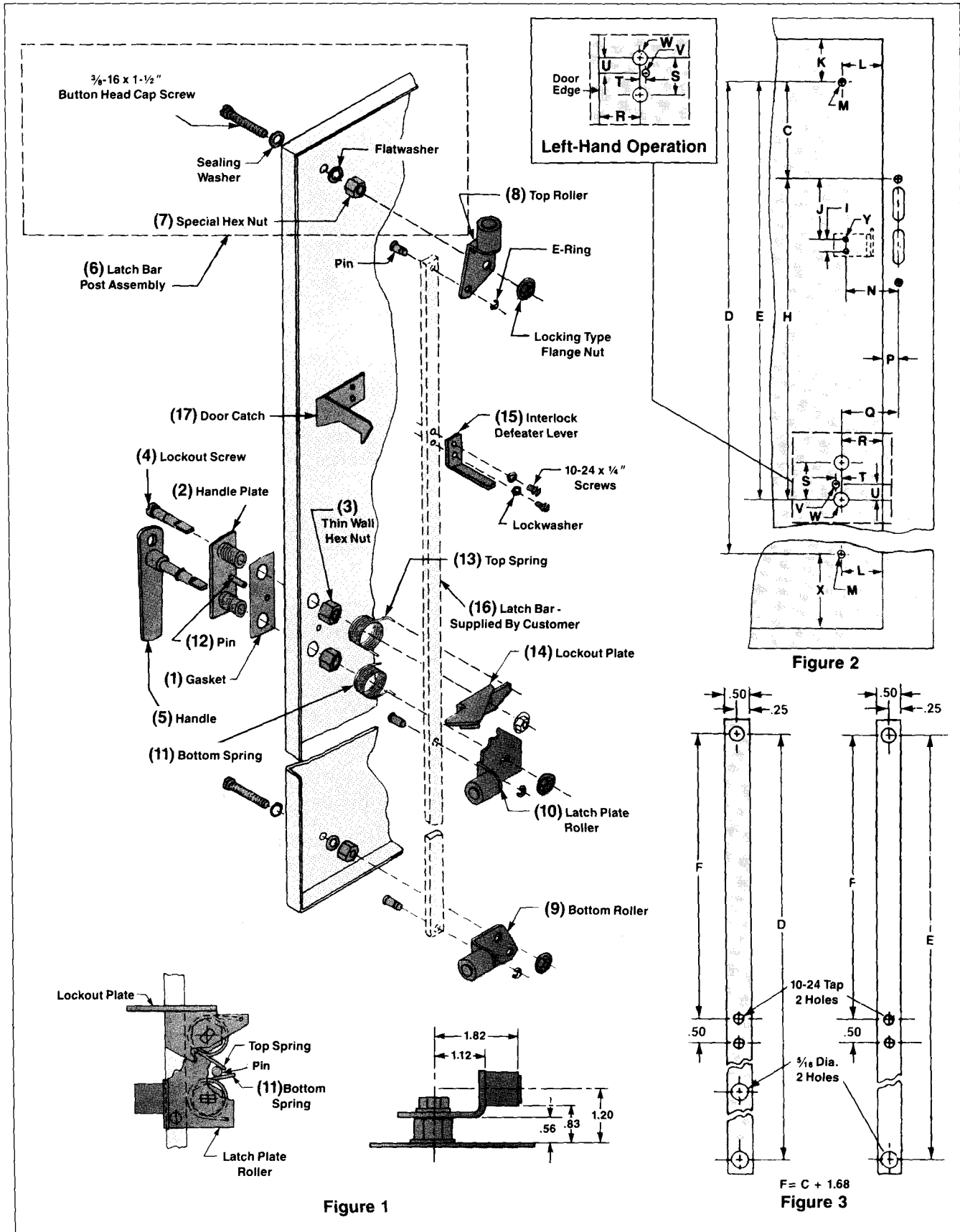

I-T-E TELEMANT[®] Electric Motor Operator

(MOF6120, MOF6120L, MOF6240, MOF6240L)^①

(MOF6125DC, MOF6048DC)

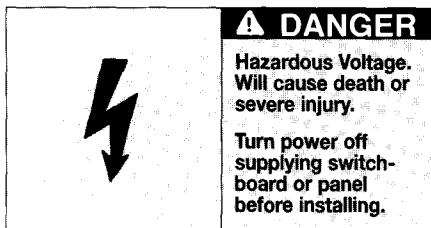

⚠ SAFETY INSTRUCTIONS

General

The motor operated mechanism is designed to open, close and reset a circuit breaker or switch by remote control. The customer must supply the circuit breaker or switch, normally ON and OFF push-buttons, external wiring, a control power source, and all control logic. Consult the wiring diagram (Figure 4) for a typical control connection.

Installation

- A. Turn off and lock out all power supplying circuit breaker and motor operator before installation or servicing.
- B. Attach the circuit breaker to its mounting surface using the mounting washers (1) and mounting screws (2) supplied with the motor operator (Figure 1). Refer to installation dimensions (Figure 3).
- C. With its cover open, attach the motor operator to the circuit breaker using four #10-32 truss head mounting screws (3) provided (Figure 1).
- D. Align the motor operator mechanism rollers and the circuit breaker handle by rotating the lead screw with a screwdriver (Figure 2). Lead screw access hole is at the bottom of the motor operator (Figure 2).
- E. Close and latch the mechanism cover.
- F. Complete the desired control connections and electrically test the motor operator system before reenergizing the breaker power terminals in accordance with the electrical operation.

^①The motor operator is hinged for opening to the left or right dependent on catalog number designation. The "L" suffix is for the motor operators hinged to the left. No suffix is for the motor operator hinged to the right.

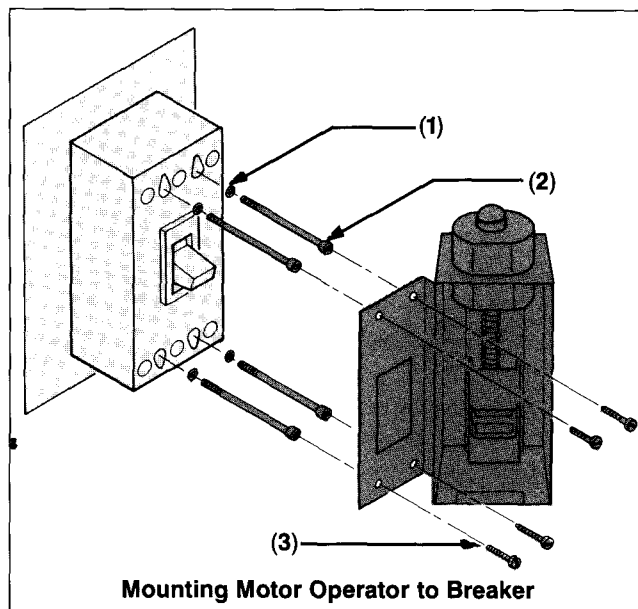

Figure 1

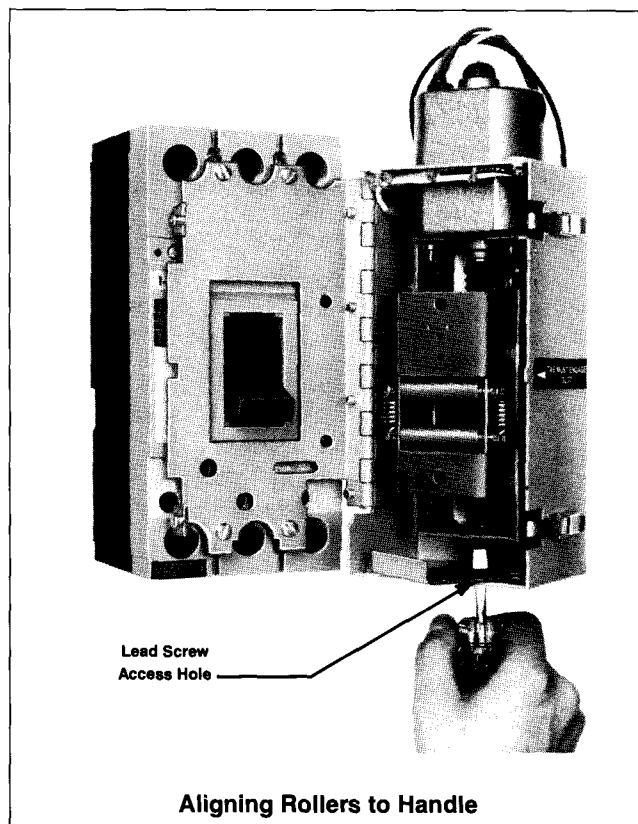

Figure 2

Dimensions

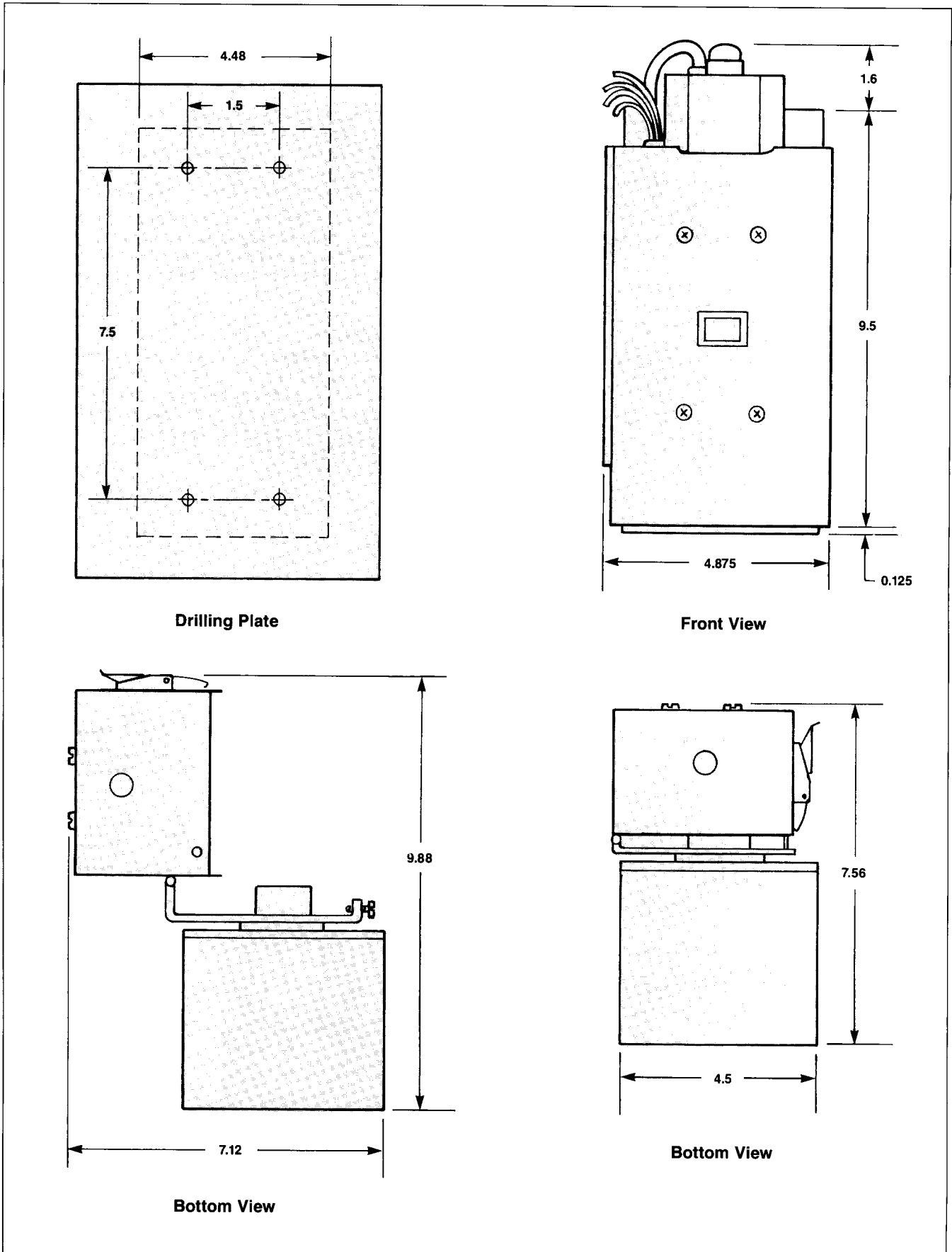

Figure 3

I-T-E TELEMAND® Electric Motor Operator

Operation

Electrical Operation

With the breaker and the operating mechanism in the OFF position, press the ON button to energize the motor. This action will close the breaker. When the breaker handle reaches the ON position, the motor circuit is disconnected by an internal limit switch.

With the breaker and the operating mechanism in the ON position, press the OFF button to energize the motor. This action will open the breaker. When the breaker handle reaches the OFF position, the motor circuit is disconnected by an internal limit switch.

When the circuit breaker trips automatically, there is no external indication that the breaker has tripped unless a separate bell alarm accessory is provided to energize a customer furnished warning device. After the circuit breaker trips automatically, it is necessary to press the OFF button to move the breaker handle to the reset position.

Automatic Reset

For automatic reset, an auxiliary switch is used to return the breaker to the OFF/RESET position after it has been tripped. NOTE: Separate auxiliary contact must be provided by customer. This auxiliary switch is mounted inside the breaker and wired parallel with the OFF button. When the breaker trips, the auxiliary switch closes, thus energizing the motor circuit which moves the breaker to the OFF/RESET position.

After the motor operated mechanism has reset the breaker, the motor operator toggle switch, internal limit switch, again opens the circuit. To provide automatic reset, the ON push-button must be a single pole double throw device and it must be wired per Figure 4.

Manual Operation

Operate the two cover latches and swing the hinged motor operator cover away from the breaker to expose the breaker handle. To return to electrical operation, follow the installation instructions, deleting Steps B and C. After operation checks are complete, restore to normal operation.

Electrical Characteristics^①

Catalog Number	Operating Voltage	Operating Current
MOF6120 MOF6120L	120V AC	10.0 Amps In-Rush 5.5 Amps Running
MOF6240 MOF6240L	240V AC	4.7 Amps In-Rush 2.8 Amps Running
MOF6125DC	125V DC	14.3 Amps In-Rush 7.0 Amps Running
MOF6048DC	48V DC	23.5 Amps In-Rush 12.5 Amps Running

^① Closing or opening speed 0.3 seconds

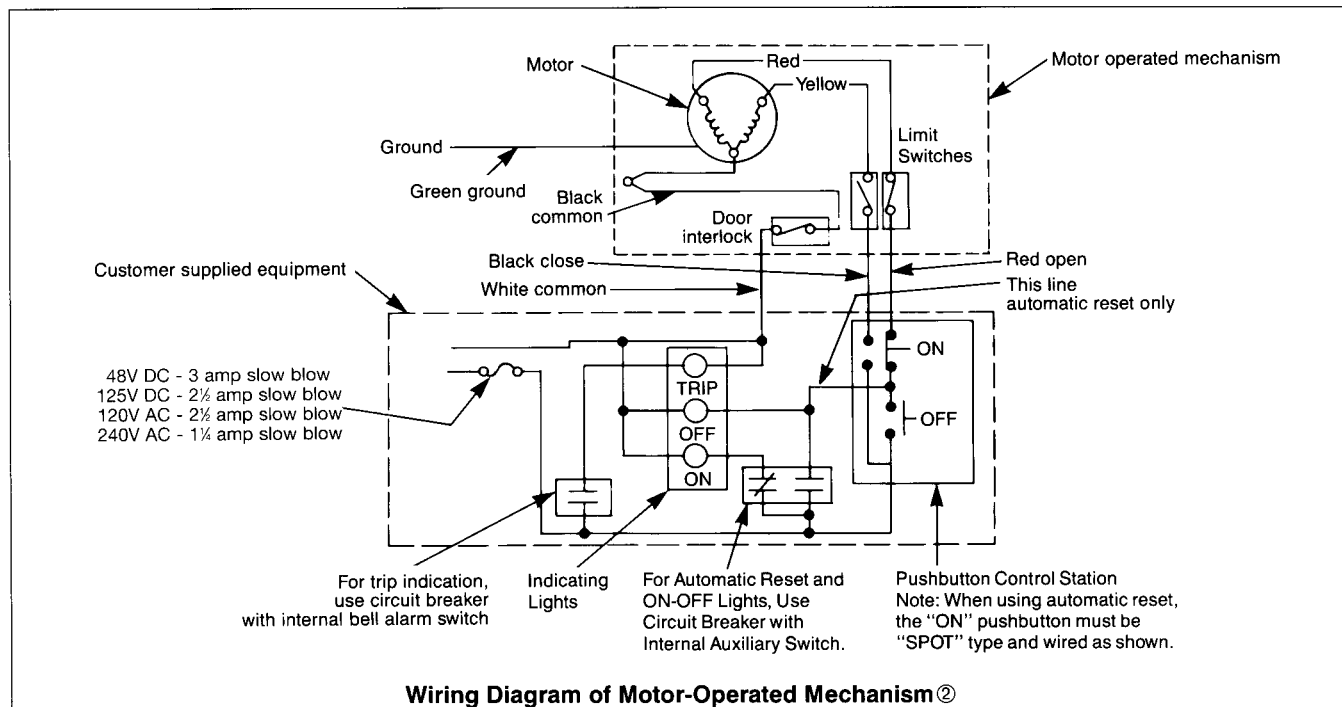
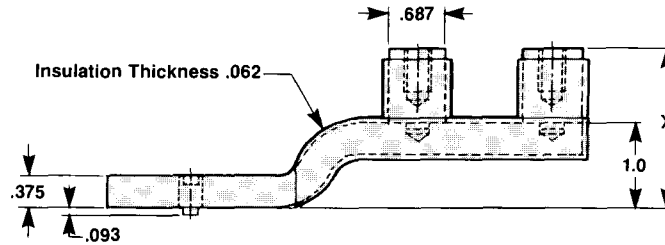
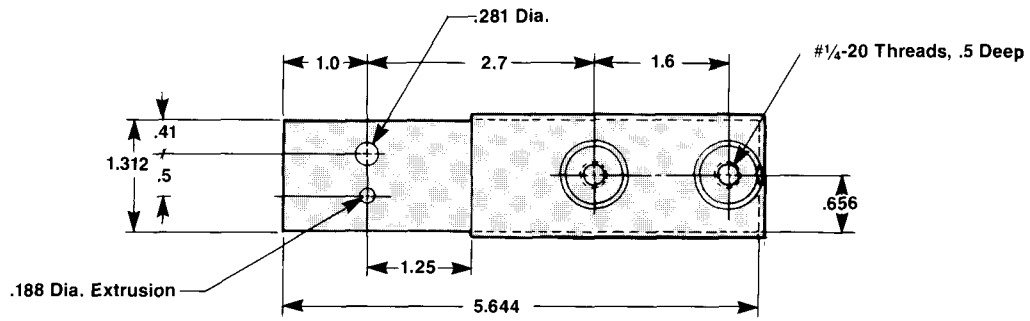

Figure 4

^②All switch contacts shown with circuit breaker in the ON position.

I-T-E Panelboard Connector Straps^①



Outside Connector Strap

Catalog Number	X
CS3610R	1.875
CS3612R	3.437

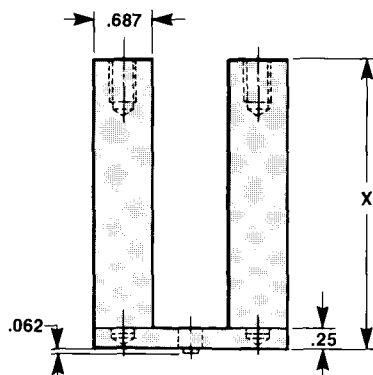
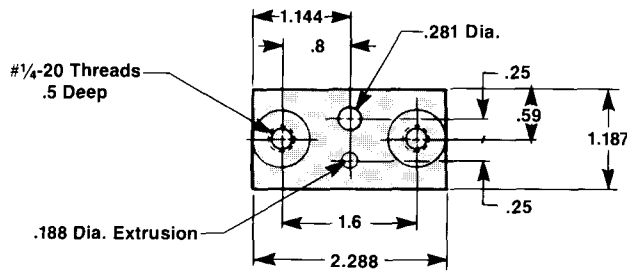

Inside Connector Strap

Catalog Number	X
CS3611R	1.875
CS3613R	3.437

① These straps are not used in series 6 or 7A panelboards.

I-T-E Enclosures

Type I — F6N1S

General purpose indoor, sheet-steel enclosure for use in normal atmosphere, listed as service-entrance equipment.

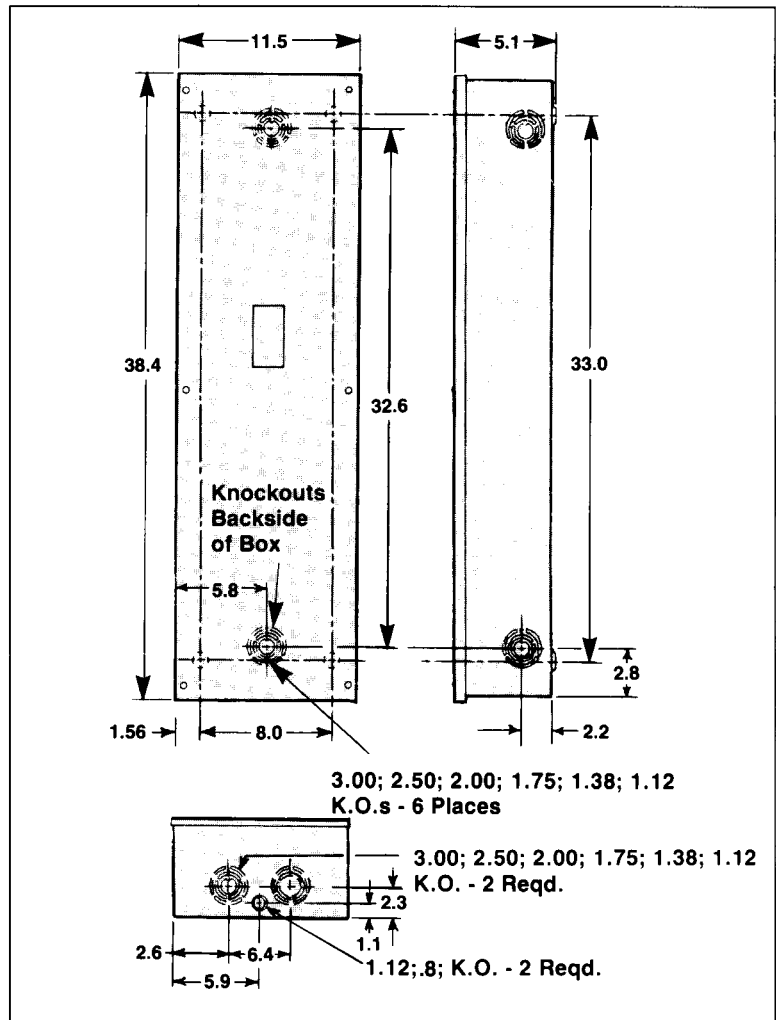

Type 12K — F6N12K

A special-industry, sheet-steel enclosure for indoor use in atmosphere containing particles of lint, dust, dirt, sawdust and other foreign matter.

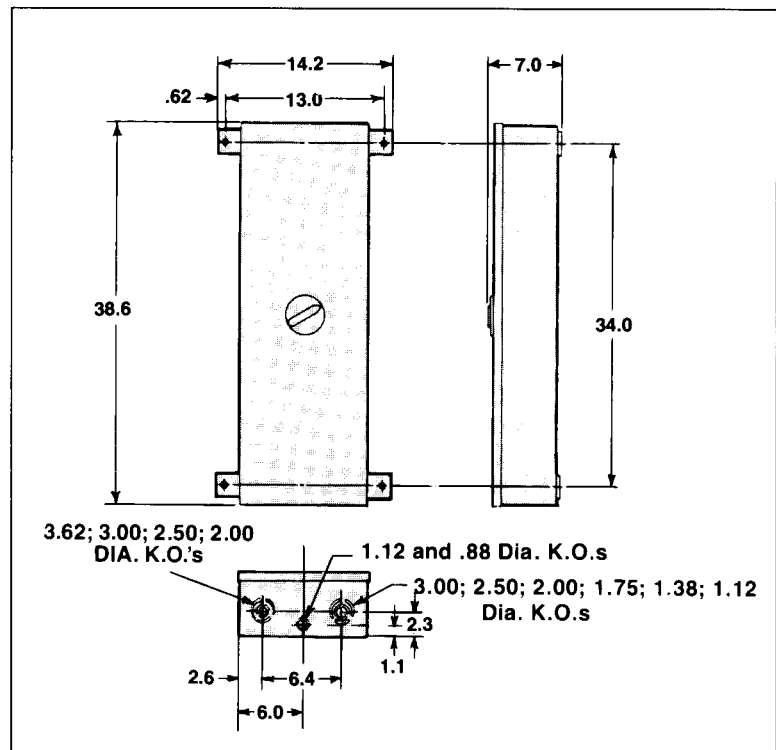

I-T-E Enclosures

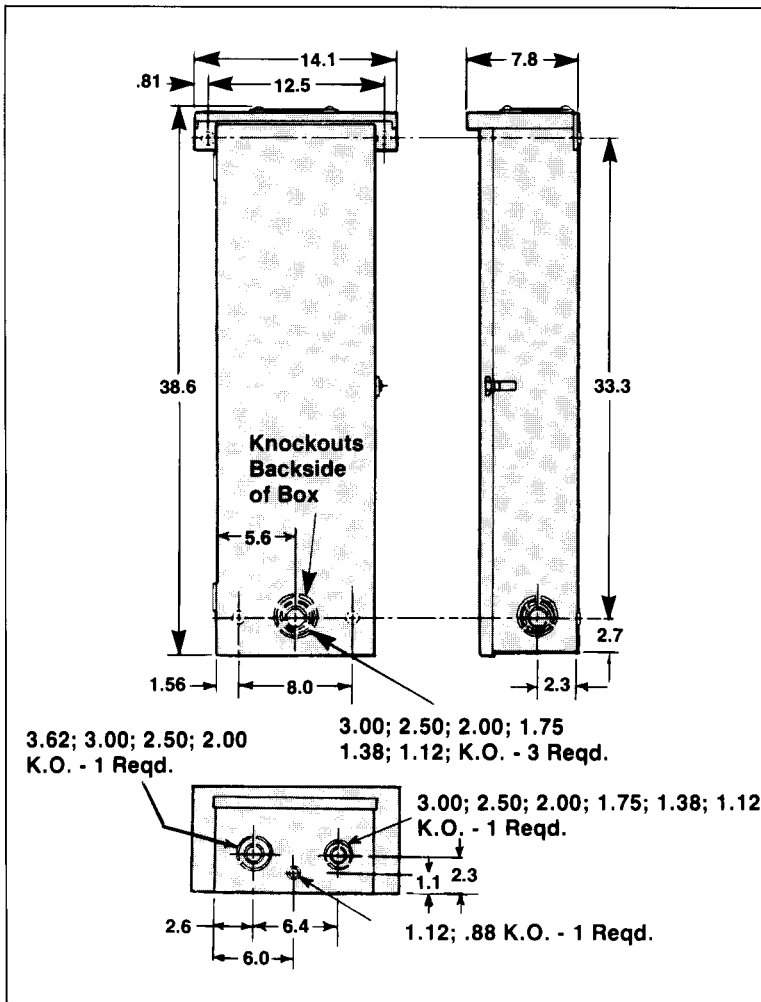

Type 3R — F6N3R

An outdoor, sheet-steel enclosure providing protection against driving rain, sleet or snow. Listed as service-entrance equipment.

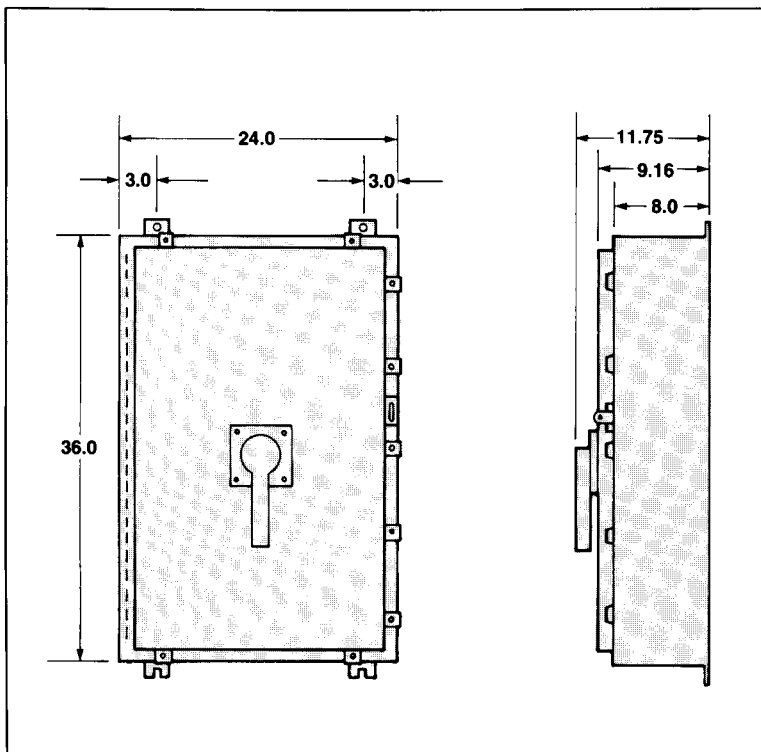

Types 4, 4X — FD6SS4

Type 304 stainless steel — an indoor or outdoor enclosure providing protection against corrosion, wind blown dust, rain, splashing water and hose directed water.

FD-Frame Time Current Curve

Type CFD6

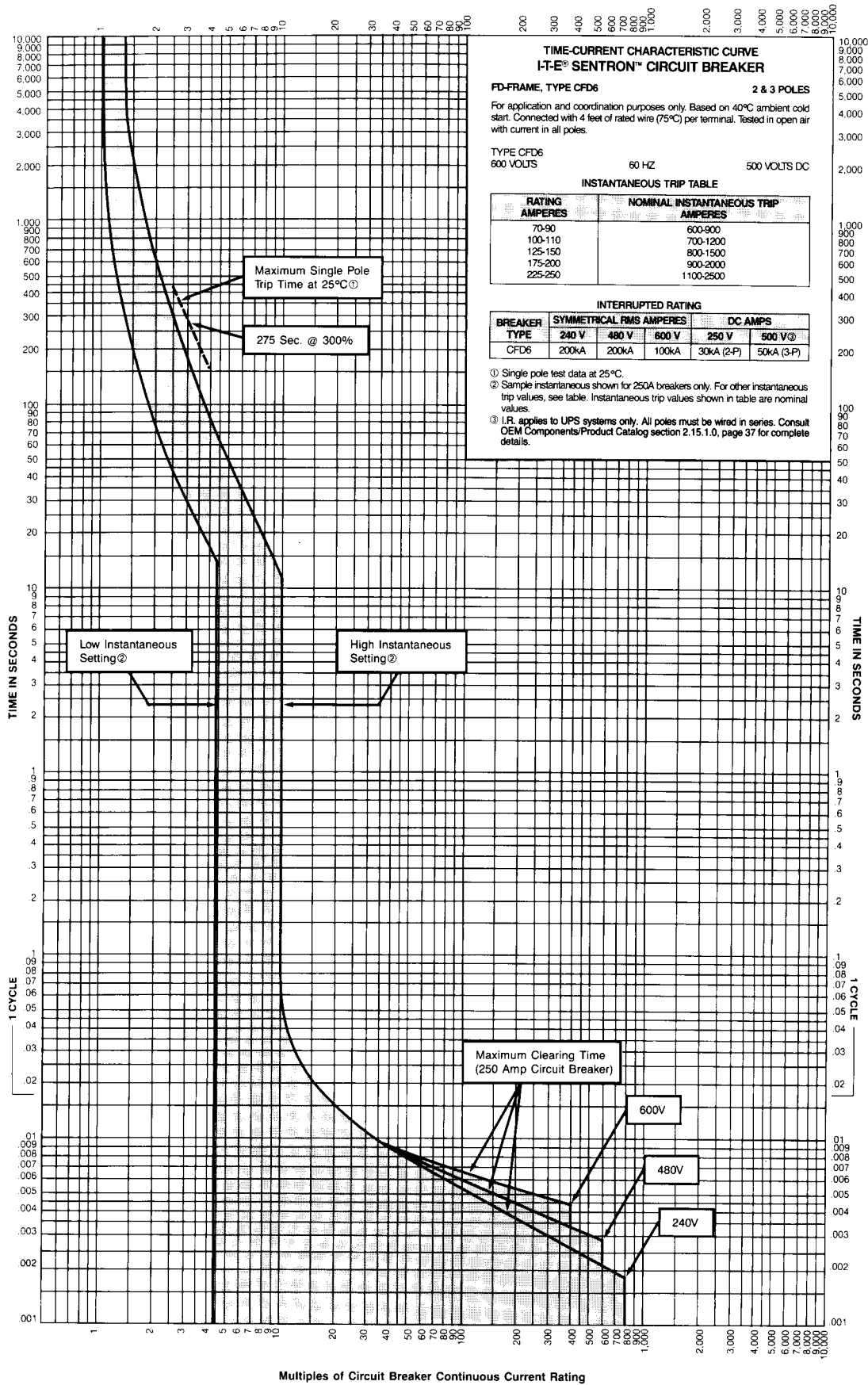

FD-Frame Time Current Curve

Types FXD6A, FD6A, HFXD6, HFD6, HHFD6, HHFXD6A

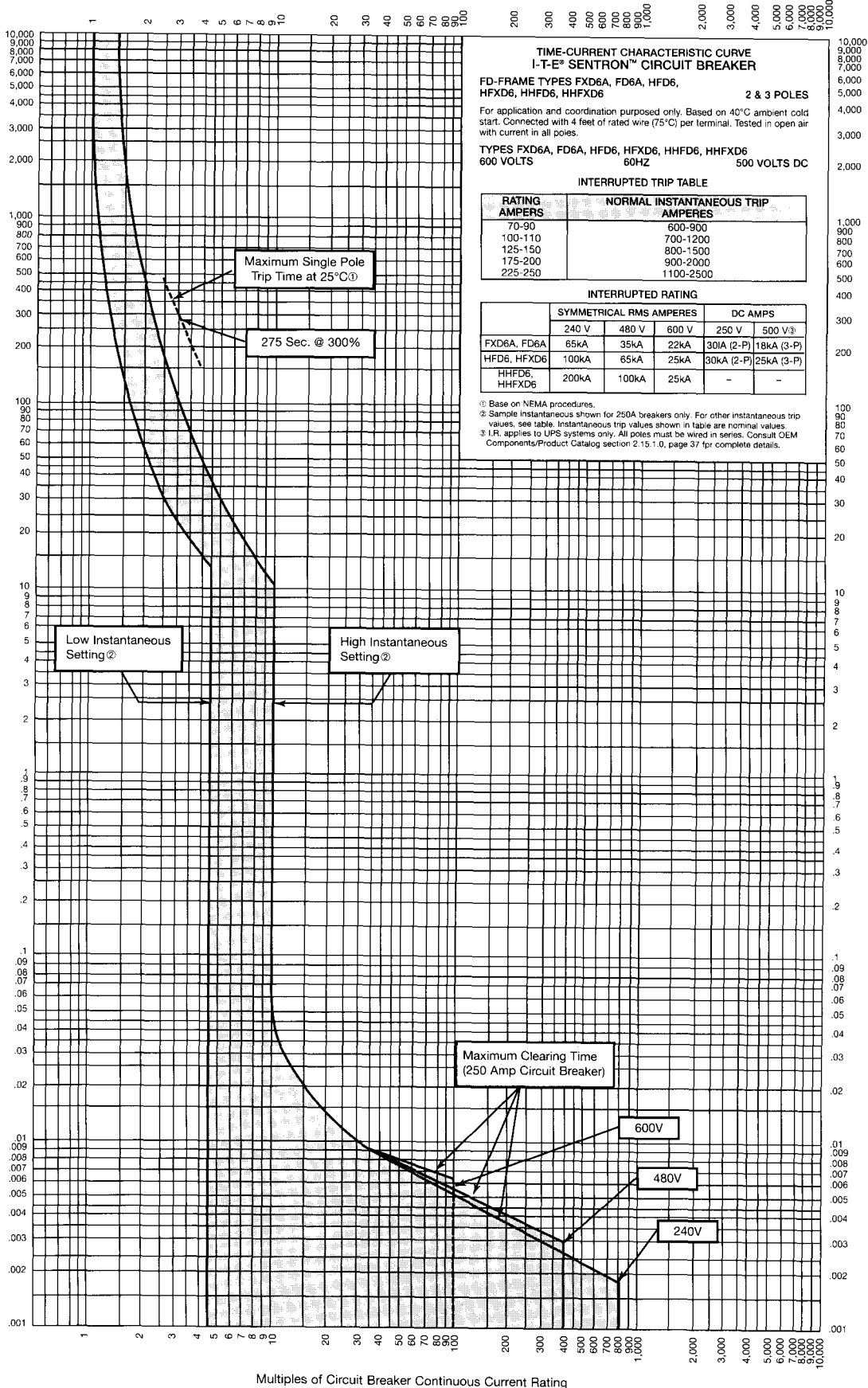

FD-Frame Peak Let-Thru Current (I_p) Curve

Type CFD6

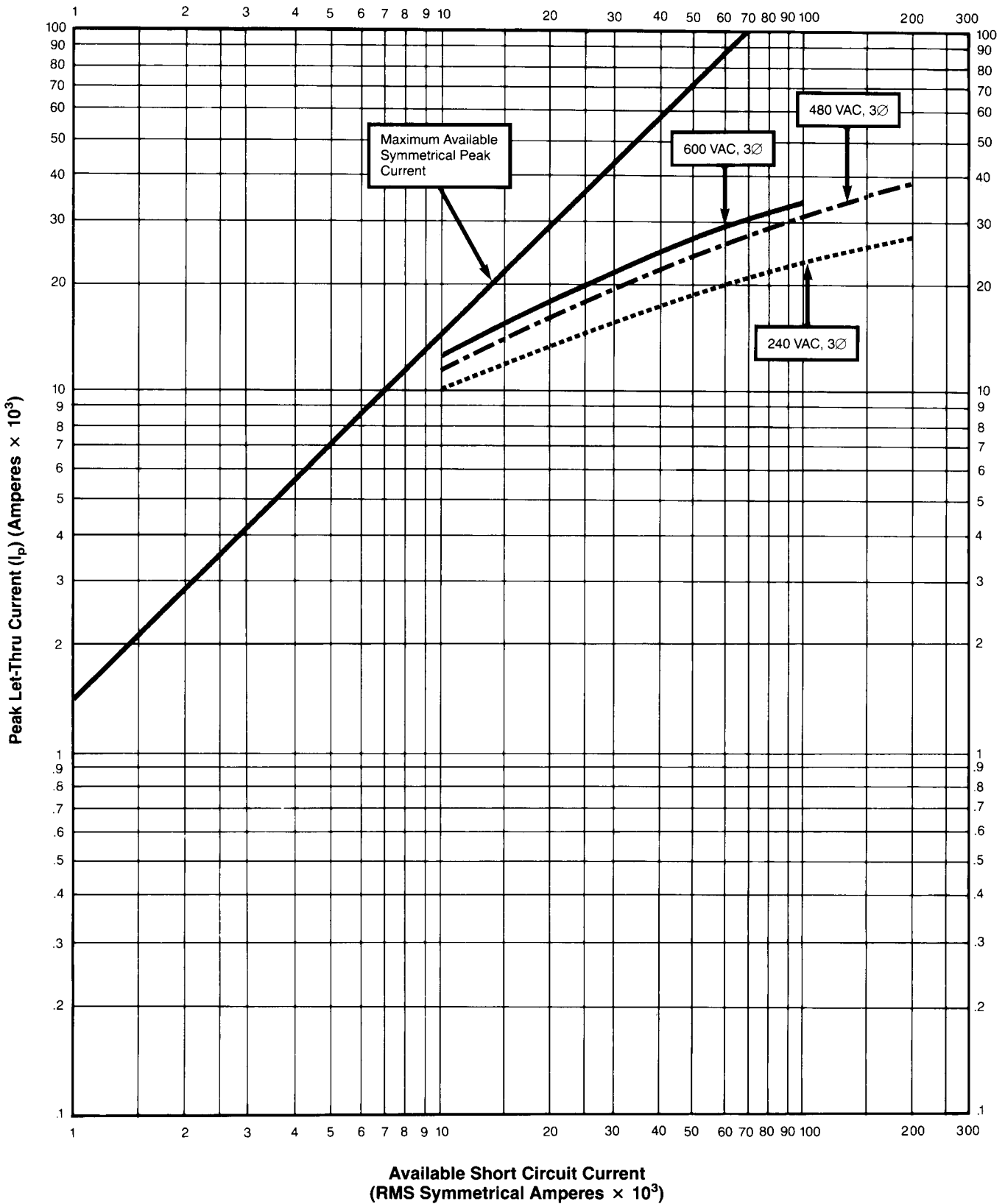

TD-7103-A (REV. 1)
MARCH 1989

FD-Frame Let-Thru I²t Curve

Type CFD6

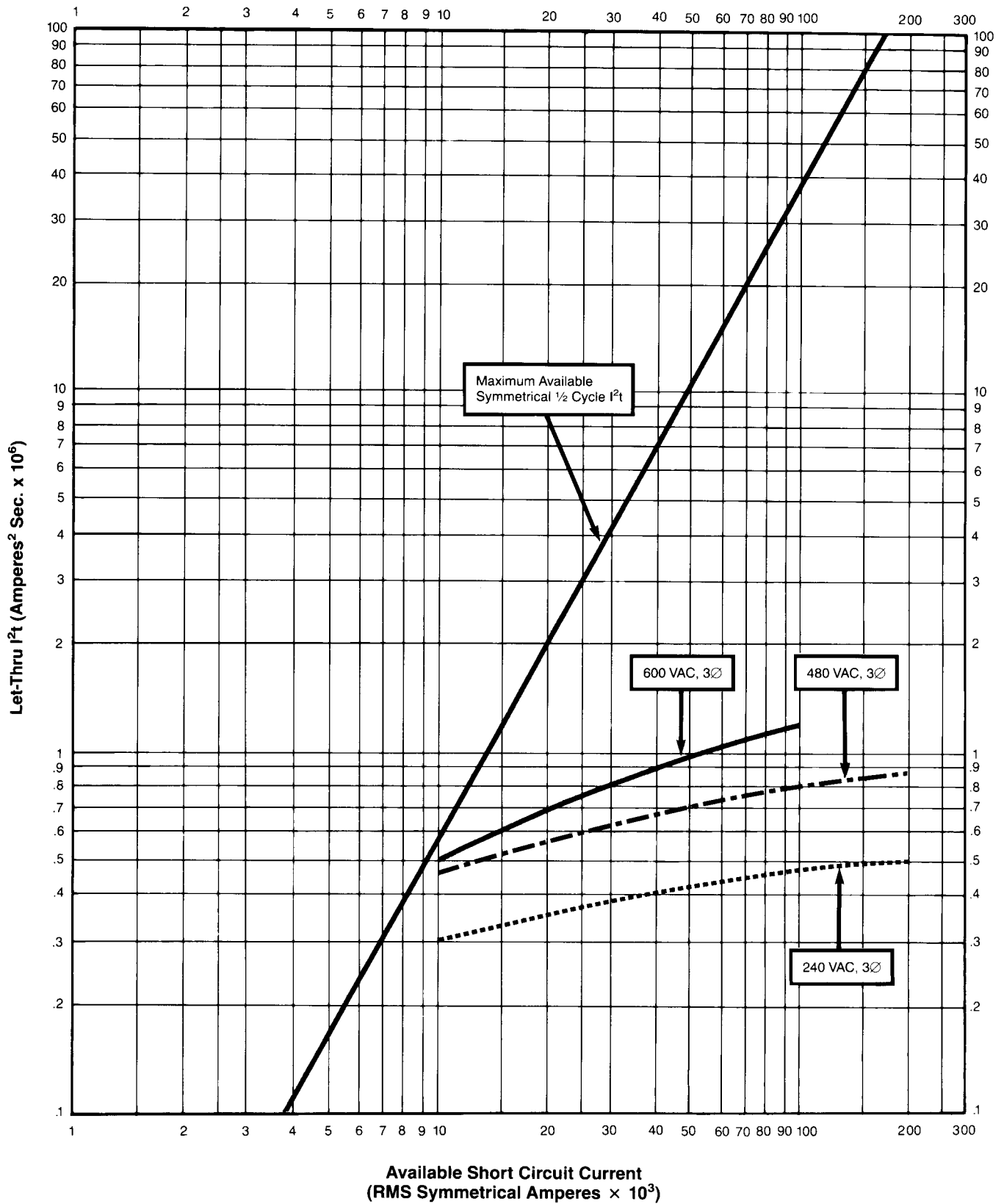

TD-7103-B (REV. 1)
MARCH 1989

Ordering Information—Circuit Breaker Catalog Numbers

FXD6A Non-Interchangeable Trip ⑧

Ampere Rating	Instantaneous Trip Range		Complete 2-Pole ① Breaker Unenclosed	Complete 3-Pole Breaker Unenclosed	UL Interrupting Ratings (kA) (RMS Symmetrical Amperes) ⑤				
	Min.	Max.	Catalog Number ②	Catalog Number ②	Volts AC			Volts DC	
					240	480	600	250 ⑥	500 ⑦
70	600	900	FXD62B070	FXD63B070	65	35	22	30	18
80	600	900	FXD62B080	FXD63B080	65	35	22	30	18
90	600	900	FXD62B090	FXD63B090	65	35	22	30	18
100	700	1200	FXD62B100	FXD63B100	65	35	22	30	18
110	700	1200	FXD62B110	FXD63B110	65	35	22	30	18
125	800	1500	FXD62B125	FXD63B125	65	35	22	30	18
150	800	1500	FXD62B150	FXD63B150	65	35	22	30	18
175	900	2000	FXD62B175	FXD63B175	65	35	22	30	18
200	900	2000	FXD62B200	FXD63B200	65	35	22	30	18
225	1100	2500	FXD62B225	FXD63B225	65	35	22	30	18
250	1100	2500	FXD62B250	FXD63B250	65	35	22	30	18
250	Molded Case Switch ④		FXD62S250A	FXD63S250A	65	35	22	30	N/A
SHIPPING: 12 lb.									

FD6A Interchangeable Trip: 2 Pole ①

Ampere Rating	Instantaneous Trip Range		Complete Breaker Unenclosed	Frame Only	Trip Unit Only	UL Interrupting Ratings (kA) (RMS Symmetrical Amperes) ⑤				
	Min.	Max.	Catalog Number ②	Catalog Number	Catalog Number ③	Volts AC			Volts DC	
						240	480	600	250	500
70	600	900	FD62B070	FD62F250	FD62T070	65	35	22	30	N/A
80	600	900	FD62B080	FD62F250	FD62T080	65	35	22	30	N/A
90	600	900	FD62B090	FD62F250	FD62T090	65	35	22	30	N/A
100	700	1200	FD62B100	FD62F250	FD62T100	65	35	22	30	N/A
110	700	1200	FD62B110	FD62F250	FD62T110	65	35	22	30	N/A
125	800	1500	FD62B125	FD62F250	FD62T125	65	35	22	30	N/A
150	800	1500	FD62B150	FD62F250	FD62T150	65	35	22	30	N/A
175	900	2000	FD62B175	FD62F250	FD62T175	65	35	22	30	N/A
200	900	2000	FD62B200	FD62F250	FD62T200	65	35	22	30	N/A
225	1100	2500	FD62B225	FD62F250	FD62T225	65	35	22	30	N/A
250	1100	2500	FD62B250	FD62F250	FD62T250	65	35	22	30	N/A
SHIPPING:			12 lb.	9 lb.	3 lb.					

3-Pole ①

70	600	900	FD63B070	FD63F250	FD63T070	65	35	18	N/A	18
80	600	900	FD63B080	FD63F250	FD63T080	65	35	18	N/A	18
90	600	900	FD63B090	FD63F250	FD63T090	65	35	18	N/A	18
100	700	1200	FD63B100	FD63F250	FD63T100	65	35	18	N/A	18
110	700	1200	FD63B110	FD63F250	FD63T110	65	35	18	N/A	18
125	800	1500	FD63B125	FD63F250	FD63T125	65	35	18	N/A	18
150	800	1500	FD63B150	FD63F250	FD63T150	65	35	18	N/A	18
175	900	2000	FD63B175	FD63F250	FD63T175	65	35	18	N/A	18
200	900	2000	FD63B200	FD63F250	FD63T200	65	35	18	N/A	18
225	1100	2500	FD63B225	FD63F250	FD63T225	65	35	18	N/A	18
250	1100	2500	FD63B250	FD63F250	FD63T250	65	35	18	N/A	18
SHIPPING:			12 lb.	9 lb.	3 lb.					

① Two-pole available in 3-pole width only.

② For 50°C application replace "B" letter in catalog number with the letter "M" for ordering purposes.

③ If trip unit is required, replace the letter "T" with the letter "W" for ordering purposes.

④ Includes self-protecting instantaneous element. - Interruption rating when protected by thermal/magnetic breaker.

⑤ IEC interrupting ratings for 3-pole circuit breakers are listed on page 53.

⑥ Two-pole rating only.

⑦ Three-pole rating only. Properly wired as shown on page 4.

⑧ FXD6A circuit breakers are UL listed for reverse feed applications.

Ordering Information—Circuit Breaker Catalog Numbers

HFXD6 Non-Interchangeable Trip

Ampere Rating	Instantaneous Trip Range		Complete 2 Pole ^① Breaker Unenclosed	Complete 3 Pole Breaker Unenclosed	UL Interrupting Ratings (kA) (RMS Symmetrical Amperes) ^⑤				
	Min.	Max.	Catalog Number ^②	Catalog Number ^②	Volts AC			Volts DC	
					240	480	600	250 ^⑥	500 ^⑦
70	600	900	HFXD62B070	HFXD63B070	100	65	25	30	25
80	600	900	HFXD62B080	HFXD63B080	100	65	25	30	25
90	600	900	HFXD62B090	HFXD63B090	100	65	25	30	25
100	700	1200	HFXD62B100	HFXD63B100	100	65	25	30	25
110	700	1200	HFXD62B110	HFXD63B110	100	65	25	30	25
125	800	1500	HFXD62B125	HFXD63B125	100	65	25	30	25
150	800	1500	HFXD62B150	HFXD63B150	100	65	25	30	25
175	900	2000	HFXD62B175	HFXD63B175	100	65	25	30	25
200	900	2000	HFXD62B200	HFXD63B200	100	65	25	30	25
225	1100	2500	HFXD62B225	HFXD63B225	100	65	25	30	25
250	1100	2500	HFXD62B250	HFXD63B250	100	65	25	30	25

SHIPPING: 12 lb.

HFD6 Interchangeable Trip: 2-Pole ^①

Ampere Rating	Instantaneous Trip Range		Complete Breaker Unenclosed	Frame Only	Trip Unit Only	UL Interrupting Ratings (kA) (RMS Symmetrical Amperes) ^⑤				
	Min.	Max.	Catalog Number ^②	Catalog Number	Catalog Number ^③	Volts AC			Volts DC	
						240	480	600	250	500
70	600	900	HFD62B070	HFD62F250	FD62T070	100	65	25	30	N/A
80	600	900	HFD62B080	HFD62F250	FD62T080	100	65	25	30	N/A
90	600	900	HFD62B090	HFD62F250	FD62T090	100	65	25	30	N/A
100	700	1200	HFD62B100	HFD62F250	FD62T100	100	65	25	30	N/A
110	700	1200	HFD62B110	HFD62F250	FD62T110	100	65	25	30	N/A
125	800	1500	HFD62B125	HFD62F250	FD62T125	100	65	25	30	N/A
150	800	1500	HFD62B150	HFD62F250	FD62T150	100	65	25	30	N/A
175	900	2000	HFD62B175	HFD62F250	FD62T175	100	65	25	30	N/A
200	900	2000	HFD62B200	HFD62F250	FD62T200	100	65	25	30	N/A
225	1100	2500	HFD62B225	HFD62F250	FD62T225	100	65	25	30	N/A
250	1100	2500	HFD62B250	HFD62F250	FD62T250	100	65	25	30	N/A

SHIPPING: 12 lb. 9 lb. 3 lb.

3-Pole

70	600	900	HFD63B070	HFD63F250	FD63T070	100	65	25	N/A	25
80	600	900	HFD63B080	HFD63F250	FD63T080	100	65	25	N/A	25
90	600	900	HFD63B090	HFD63F250	FD63T090	100	65	25	N/A	25
100	700	1200	HFD63B100	HFD63F250	FD63T100	100	65	25	N/A	25
110	700	1200	HFD63B110	HFD63F250	FD63T110	100	65	25	N/A	25
125	800	1500	HFD63B125	HFD63F250	FD63T125	100	65	25	N/A	25
150	800	1500	HFD63B150	HFD63F250	FD63T150	100	65	25	N/A	25
175	900	2000	HFD63B175	HFD63F250	FD63T175	100	65	25	N/A	25
200	900	2000	HFD63B200	HFD63F250	FD63T200	100	65	25	N/A	25
225	1100	2500	HFD63B225	HFD63F250	FD63T225	100	65	25	N/A	25
250	1100	2500	HFD63B250	HFD63F250	FD63T250	100	65	25	N/A	25

SHIPPING: 12 lb. 9 lb. 3 lb.

^① Two-pole available in 3-pole width only.

^② For 50°C application replace "B" letter in catalog number with the letter "M" for ordering purposes.

Ordering Information — Circuit Breaker Catalog Numbers

HHFXD6 Non-Interchangeable Trip

Amperes Rating	Instantaneous Trip Range		Complete 2 Pole ^① Breaker Uninclosed	Complete 3 Pole Breaker Uninclosed	UL Interrupting Ratings (kA) (RMS Symmetrical Amperes)				
	Min.	Max.	Catalog Number ^②	Catalog Number ^②	Volts AC			Volts DC	
					240	480	600	250	500
70	600	900	HHFXD62B070	HHFXD63B070	200	100	25	N/A	N/A
80	600	900	HHFXD62B080	HHFXD63B080	200	100	25	N/A	N/A
90	600	900	HHFXD62B090	HHFXD63B090	200	100	25	N/A	N/A
100	700	1200	HHFXD62B100	HHFXD63B100	200	100	25	N/A	N/A
110	700	1200	HHFXD62B110	HHFXD63B110	200	100	25	N/A	N/A
125	800	1500	HHFXD62B125	HHFXD63B125	200	100	25	N/A	N/A
150	800	1500	HHFXD62B150	HHFXD63B150	200	100	25	N/A	N/A
175	900	2000	HHFXD62B175	HHFXD63B175	200	100	25	N/A	N/A
200	900	2000	HHFXD62B200	HHFXD63B200	200	100	25	N/A	N/A
225	1100	2500	HHFXD62B225	HHFXD63B225	200	100	25	N/A	N/A
250	1100	2500	HHFXD62B250	HHFXD63B250	200	100	25	N/A	N/A
SHIPPING: 12lb.									

HHFD6 Interchangeable Trip: 2 Pole

70	600	900	HHFD62B070	HHFD62F250	FD62T070	200	100	25	N/A	N/A
80	600	900	HHFD62B080	HHFD62F250	FD62T080	200	100	25	N/A	N/A
90	600	900	HHFD62B090	HHFD62F250	FD62T090	200	100	25	N/A	N/A
100	700	1200	HHFD62B100	HHFD62F250	FD62T100	200	100	25	N/A	N/A
110	700	1200	HHFD62B110	HHFD62F250	FD62T110	200	100	25	N/A	N/A
125	800	1500	HHFD62B125	HHFD62F250	FD62T125	200	100	25	N/A	N/A
150	800	1500	HHFD62B150	HHFD62F250	FD62T150	200	100	25	N/A	N/A
175	900	2000	HHFD62B175	HHFD62F250	FD62T175	200	100	25	N/A	N/A
200	900	2000	HHFD62B200	HHFD62F250	FD62T200	200	100	25	N/A	N/A
225	1100	2500	HHFD62B225	HHFD62F250	FD62T225	200	100	25	N/A	N/A
250	1100	2500	HHFD62B250	HHFD62F250	FD62T250	200	100	25	N/A	N/A
SHIPPING:			12lb.	9 lb.	3lb.					

3-Pole

70	600	900	HHFD63B070	HHFD63F250	FD63T070	200	100	25	N/A	N/A
80	600	900	HHFD63B080	HHFD63F250	FD63T080	200	100	25	N/A	N/A
90	600	900	HHFD63B090	HHFD63F250	FD63T090	200	100	25	N/A	N/A
100	700	1200	HHFD63B100	HHFD63F250	FD63T100	200	100	25	N/A	N/A
110	700	1200	HHFD63B110	HHFD63F250	FD63T110	200	100	25	N/A	N/A
125	800	1500	HHFD63B125	HHFD63F250	FD63T125	200	100	25	N/A	N/A
150	800	1500	HHFD63B150	HHFD63F250	FD63T150	200	100	25	N/A	N/A
175	900	2000	HHFD63B175	HHFD63F250	FD63T175	200	100	25	N/A	N/A
200	900	2000	HHFD63B200	HHFD63F250	FD63T200	200	100	25	N/A	N/A
225	1100	2500	HHFD63B225	HHFD63F250	FD63T225	200	100	25	N/A	N/A
250	1100	2500	HHFD63B250	HHFD63F250	FD63T250	200	100	25	N/A	N/A
SHIPPING:			12lb.	9 lb.	3lb.					

CFD6 Non-Interchangeable Trip

70	600	900	CFD62B070	CFD63B070	200	150	100	30	N/A
80	600	900	CFD62B080	CFD63B080	200	150	100	30	N/A
90	600	900	CFD62B090	CFD63B090	200	150	100	30	N/A
100	700	1200	CFD62B100	CFD63B100	200	150	100	30	N/A
110	700	1200	CFD62B110	CFD63B110	200	150	100	30	N/A
125	800	1500	CFD62B125	CFD63B125	200	150	100	30	N/A
150	800	1500	CFD62B150	CFD63B150	200	150	100	30	N/A
175	900	2000	CFD62B175	CFD63B175	200	150	100	30	N/A
200	900	2000	CFD62B200	CFD63B200	200	150	100	30	N/A
225	1100	2500	CFD62B225	CFD63B225	200	150	100	30	N/A
250	1100	2500	CFD62B250	CFD63B250	200	150	100	30	N/A
250	Molded Case Switch ^④		CFD62S250A	CFD63S250A	200	150	100	30	N/A
SHIPPING:			2-pole, 12 lbs.	3-pole 14 lbs.					

Ordering Information

Instantaneous Trip Circuit Breakers; Accessory Combinations

Instantaneous Trip (Motor Circuit Protectors)

Ampere Rating	Complete Breaker Unenclosed				Instantaneous Trip Range	
	Catalog Number				Minimum	Maximum
	FXD6-ETI, 2-Pole	FXD6-ETI, 3-Pole	CFD6-ETI, 2-Pole	CFD6-ETI, 3-Pole		
150, Low	FXD62L150	FXD63L150	CFD62L150	CFD63L150	400	800
150, Stand.	FXD62A150	FXD63A150	CFD62A150	CFD63A150	800	1500
250, Stand.	FXD62A250	FXD63A250	CFD62A250	CFD63A250	1100	2500
SHIPPING:	7 lb.	9 lb.	12 lb.	12 lb.		

Auxiliary Switch

Control Voltage		1 Auxiliary Switch	1 Alarm Switch and 1 Auxiliary Switch	2 Auxiliary Switches
AC	DC	Catalog Number	Catalog Number	Catalog Number
120		A01FD62	C01FD64	A02FD62
208		A01FD62	C01FD64	A02FD62
240		A01FD62	C01FD64	A02FD62
277		A01FD64	C01FD64	A02FD64
480		A01FD64	C01FD64	A02FD64
600		N/A	N/A	N/A
	24	A01FD62	C01FD64	A02FD62
	48	A01FD62	C01FD64	A02FD62
	125	A01FD62	C01FD64	A02FD62
	250	A01FD62	C01FD64	A02FD62

Undervoltage Trip

Control Voltage		1 Undv. Trip	1 Und. Trip & 1 Aux. Switch
AC	DC	Catalog Number	Catalog Number
120		U01FD60	W01FD64
208		U02FD60	W02FD64
240		U03FD60	W03FD64
277		U16FD60	W16FD64
480		U06FD60	W06FD64
600		U08FD60	W08FD64
	24	U13FD60	W13FD64
	48	U14FD60	W14FD64
	125	U10FD60	W10FD64
	250	U12FD60	W12FD64

Shunt Trip

Control Voltage		1 Shunt Trip
AC	DC	Catalog Number
12		S19FD60
24		S17FD60
48		S18FD60
120		S01FD60
208		S02FD60
240		S03FD60
277		S15FD60
480		S04FD60
600		S06FD60
	24	S07FD60
	48	S09FD60
	125	S11FD60
	250	S13FD60

Bell Alarm Switch

Control Voltage		1 Alarm Switch	1 Alarm Switch and 1 Auxiliary Switch
AC	DC	Catalog Number	Catalog Number
120		B00FD64	C01FD64
208		B00FD64	C01FD64
240		B00FD64	C01FD64
277		B00FD64	C01FD64
480		B00FD64	C01FD64
600		N/A	N/A
	24	B00FD64	C01FD64
	48	B00FD64	C01FD64
	125	B00FD64	C01FD64
	250	B00FD64	C01FD64

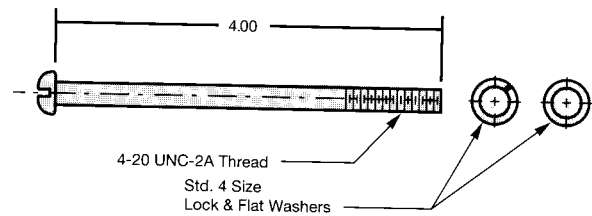

Mounting Hardware
(4 Per Device Required)

Ordering Information

Additional Accessories

Item	Catalog Number
Terminal Connectors #6-350 kcmil Cu only #4-350 kcmil Al #6-350 kcmil Cu	TC1F350 TA 1F350 TA1F350
Compression Connector	CCF250
Handle Blocking Device	FD6HB1
Padlocking Device	FD6PL1
Rear Connecting Studs Short Length—3/4" Long Long Length—71/16" Long	RS4756 RS4755
Plug-In Adapters 2-Pole (2 Required Per Breaker) 3-Pole (2 Required Per Breaker)	PC4753 PC4754
Switchboard Mounting Plates CFD6, CFD6-ETI Breaker Types All Other Types	PL4763 PL4762
Mechanical Interlocks Panel Mounted Plug-In Mounted	M15444 M15444
Rotary Handle Operators Complete Mechanism Standard Depth Variable Depth Handle Breaker Operator Shaft Standard Depth Variable Depth	CRHOFSD CRHOFVD CRHOH ^① RHOFBO RHOSSD RHOSVD
Rotary Handle Operators Standard Depth Variable Depth	F6RH1 F6RHV9

^① CRHOH is for type 1 or 12 application. For 3, 3R order RHOH; for 4-4X order RHOH4.

Item	Catalog Number
Flange Mount Handle Operator Complete Mechanism Handle Breaker Operator Standard Cable (36 in.) Optional Cable (48 in.)	FHOF036 FHOHD ^① FHOFBO FHOF036 FHOF048
Electrical Motor Operators Right Side, 120V AC Left Side, 120V AC Right Side, 240V AC Left Side, 240V AC Right Side, 125V DC Right Side, 48V DC	MOF6120 MOF612L MOF6240 MOF6240L MOF6125DC MOF6048DC
Connector Straps Outside Strap Inside Strap	CS3610R CS3612R CS3611R CS3611R CS3611R
Mounting Screw Kits	MSF6 ^① MSF650 ^②
Enclosures Type 1 Type 3R Type 12K Type 4-4x	F6N1S F6N3R F6N12K FD6SS4
Door Latch Mechanisms Left Side Right Side	DKL2, DKL3 DKR2, DKR3
Time Current Curves FXD6A, FD6A, HFXD6, HHFXD6, HHFD6 CFD6	TD-7102 TD-7103
Let-Thru Curves Peak Current (Ip) I2t	TD-7103-A TD-7103-B

- ^① Consists of 4 screws and assorted washers and/or nuts unless otherwise noted.
^② Consists of 50 screws and hardware.

UL Listings and File Numbers

I-T-E Item	UL-489 File Number	CSA Report Number
Breakers	E10848	LR13077
Terminal Connectors	E23615 (SP) ^①	
Plug-In Connectors	E23615	
Rear Studs	E23615	
Handle Operators	E57501	
Motor Operators	E57501	
Internal Accessories	E69455	LR13077
Shunt Trip		
Undervoltage Trip		
Aux. Switch		
Bell Alarm Switch		
Mechanical Interlock		
Molded Case Switch	E68312	LR42022
Enclosures	E10848	
ETI Breakers	E10848	LR42022

Industry Specifications

National Fire Protection Assoc. (National Electrical Code®).
Federal Specification W-C-375B/GEN.
Underwriters Laboratories, Inc. (UL 489).
Canadian Standards Association (C22.2 No 5).
NEMA AB-1-1986

Siemens Energy & Automation, Inc.
Power Distribution & Controls Division
3333 Old Milton Parkway
Alpharetta, GA 30005

For Nearest Sales Office
1-800-964-4114 or 800-241-4453
[www.sea.siemens.com/
sales/salesoffices.html](http://www.sea.siemens.com/sales/salesoffices.html)

For Product Information
www.sea.siemens.com/power/
