



TRANE

**General
Service
Bulletin**

CGAD-SB-2B

Library	Service Literature
Product Section	Unitary
Product	Hermetic Scroll Liquid Chillers
Model	CGAD
Literature Type	General Service Bulletin
Sequence	2
Date	December 23, 1992
File No.	SV-UN-SLC-CGAD-SB-2B 12/92
Supersedes	SV-UN-SLC-CGAD-SB-2A 4/91

Literature Change History: CGAD-SB-2 (1/90) Original.
 CGAD-SB-2A (4/91) Bulletin revised, updated service tips and added UCM part numbers. (CGAD-SB-2B (12/92) Bulletin revised, corrections made.

INFORMATIONAL

SUBJECT: CGAD, CGWD, CCAD COLD GENERATORS AND COMPRESSOR CHILLERS 20 THROUGH 60 TON UNITS WITH UNIT CONTROL MODULES (UCM).

INTRODUCTION: This service bulletin provides detailed trouble shooting information for the UCM as well as repair procedures. It is recommended that the service engineer be familiar with the UCM operation before servicing. Application Engineering Manual CON-AM-24 covers application, and operation in detail.

INDEX

PAGE

TOOL REQUIREMENTS	2
MASS TERMINATION ASSEMBLY (MTA)	2
UCM BOARD & CABLE QUICK REFERENCE	2
SERVICE TIPS	4-5
SECTION 1, TEMPERATURE SENSOR CHECKOUT	6
CONDENSER ENTERING AND LEAVING WATER SENSOR TABLE	8
OUTDOOR TEMPERATURE SENSOR TABLE	9
EVAPORATOR ENTERING AND LEAVING WATER SENSOR TABLE	10
ZONE TEMPERATURE SENSOR TABLE	11
SECTION 2, CURRENT TRANSFORMER CHECKOUT	12-14
CURRENT TRANSFORMER RESISTANCE TABLE	15
CURRENT TRANSFORMER SELECTION AND OVERLOAD DIP SWITCH SETUP TABLE	15-16
COMPRESSOR SELECTION TABLE	16
SECTION 3, POWER SUPPLY CHECKOUT	18

INDEXPAGE

POWER TRANSFORMER (1T2) CHECKOUT	19
POWER TRANSFORMER (1T12) CHECKOUT	19
POWER SUPPLY BOARD (A6) CHECKOUT	21
POWER TRANSFORMER (1T2) TABLE	22
POWER TRANSFORMER (1T12) TABLE	23
POWER SUPPLY BOARD (A6) TABLE	23
SECTION 4, RELAY OUTPUT OPTIONS BOARD CHECKOUT	24
DIAGNOSIS AT THE UCM LEVEL	25
DIAGNOSIS AT THE BOARD LEVEL	26
BOARD RELAY MANUAL OPERATION TABLE	27-28

TOOL REQUIREMENTS

Some special tools may be required to perform certain diagnostic procedures and repairs.

- * A digital volt-ohmmeter must be used for taking readings, analog meters can load down the UCM and provide inaccurate data.
- * Some procedures require the use of a wrist grounding strap, it is a requirement that it be used, failure to do so will result in further damage to the UCM.
- * A decade box will be very helpful in simulating sensor inputs to the UCM and is recommended.
- * A 25 watt pencil soldering iron, if solder repairs are necessary.

MASS TERMINATION ASSEMBLY (MTA) REPAIR, SEE FIGURE A

Like many electronic devices the UCM uses MTA's, multi wire plug connectors made by Amp Inc. The MTA uses a no strip wire connection. This connection can be difficult to verify a good contact between the wire and the terminal. The connection is made when the wire is forced into the terminal head which cuts through the insulation to the conductor. If a connection must be repaired remove the terminal from the housing by depressing the retaining clip and pulling the terminal out with the wire. Once the wire and terminal are removed from the housing the wire must be removed and the insulation stripped from the wire end. After stripping the wire using a 25 watt pencil soldering iron, solder it to the terminal head. Refer to figure A to be certain the wire is soldered opposite the retaining clip side of the terminal or it will not fit in the housing. Before installing the clip be sure the retaining clip is protruding out from the back of the terminal so it will engage the retaining hole. After the terminal is installed in the housing check to see that the retaining clip has engaged by pulling on the wire.

UCM BOARD & CABLE QUICK REFERENCE, SEE FIGURE C

<u>BOARD</u>	<u>DESCRIPTION</u>	<u>REPLACEABLE</u>	<u>PART NUMBER</u>
A1	compressor "A" & "B" input board	*	*
A2	compressor "C" & "D" input board	*	*
A3	micro board	*	*
A5	communications board, optional	yes	**BRD 705
A6	power supply board	yes	BRD 643
A7	compressor relay board #1	yes	BRD 644
A8	compressor relay board #2	yes	BRD 645
A9	output options board, alarm package/HGBP, optional	yes	**BRD 646
<u>CABLE</u>			
A9	TO MICRO-MODULE		CAB 130
A8	TO MICRO-MODULE		CAB 131
A7	TO MICRO-MODULE		CAB 132
A6	TO MICRO-MODULE		CAB 133

* REPLACE THE UCM (these boards make up the Micro-module and the replacement part is a complete UCM)

** BRD 646 and BRD 705 includes a printed circuit board and installation instructions.

MASS TERMINATION ASSEMBLY (MTA)

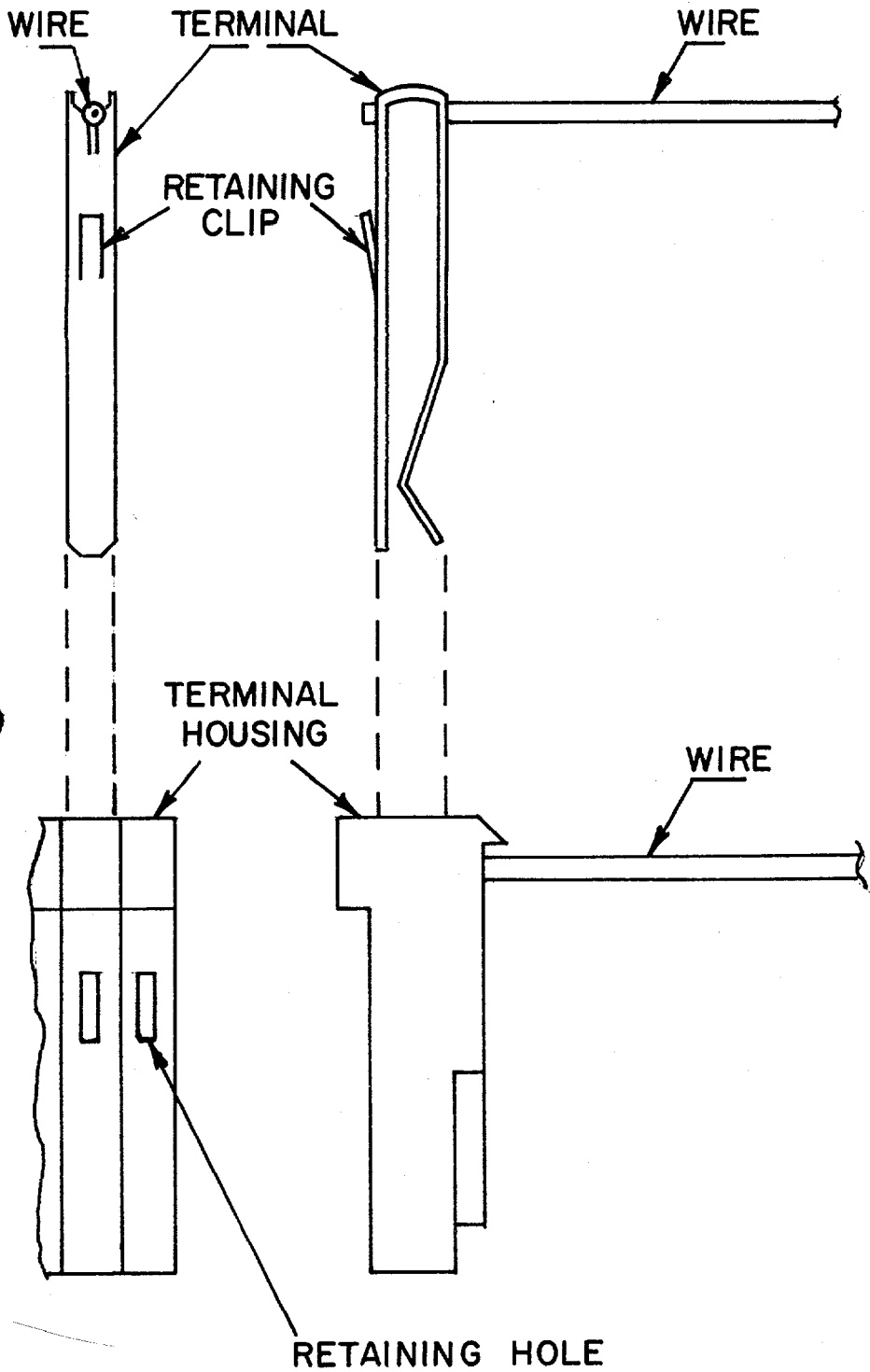

FIGURE "A"

SERVICE TIPS

8A DIAGNOSTIC Chilled Water Flow Loss

The UCM compares the entering and leaving water temperatures. This diagnostic is displayed when the entering water temperature falls below the leaving water temperature by the specified time versus trip characteristic. Normally this diagnostic occurs at startup if the chiller barrel has been piped backwards. The piping must be changed if this is the case DO NOT reverse the sensors! Extremely low water flow and if the sensors are reversed can cause this diagnostic also.

There is another condition that can cause this diagnostic that is not obvious to the servicer. If the entering water temperature sensor is installed too close to the chiller tubes (deep) it can sense the lower refrigerant temperature causing the 8A diagnostic. It has actually been observed on the display at startup the entering water being higher than the leaving then reversing after the compressor starts then changing back after the compressor shuts down. These symptoms would lead one to suspect a defective UCM. The solution is after verifying the temperature sensors are good per the checkout procedure then reposition the sensor. Loosen the nut holding the sensor just enough until the sensor moves CAUTION the chiller barrel can be under water pressure, push the sensor in until it bottoms out against the tube then pull it back one sixteenth inch, retighten the holding nut.

bA or bb DIAGNOSTIC Overload Trip Compressor A or B

This diagnostic is displayed when the overload time versus amperage characteristics of the compressor motor have been exceeded. Normally this diagnostic is associated with high motor amps or excessive starting currents. There are other conditions that will cause this diagnostic that are not obvious to the servicer. After approximately six successive trips on the low pressure switch caused by either low refrigerant charge or low ambient conditions this diagnostic can occur. If the low pressure switch trips and resets fast enough the UCM logic interprets the successive starting currents as an overload condition. Most times this will only occur on compressor A but conditions could exist to allow this diagnostic on compressor B.

Ed or A100 DISPLAYED OR ALTERNATING AT STARTUP

The UCM logic gets its power from the 1T2 and 1T12 transformers. An additional 115 volt power supply is required on terminal strip 1TB2-4 and 1TB2-11. This power can be from an optional factory supplied control power transformer or field supplied 115 volt power supply. This voltage provides power to the A7, A8, and A9 boards for relay switching. If no voltage is present and the UCM is powered, the above diagnostic or display can appear on the display.

CLEARING DIAGNOSTIC REGISTER "C"

All "C" diagnostics or "other diagnostic codes" are retained until the chiller switch is switched from STOP/RESET to either AUTO/LOCAL or AUTO/REMOTE WHILE the Advance Display switch is depressed. Turning off the power to the unit will also clear the register. It is always a good idea to check, record, and then clear this register when working on a machine. After the register is cleared it should be rechecked to see that no diagnostic codes remain.

Control Power Supply, 115 VAC

The 115 VAC power supply must be properly polarized and grounded. The hot side of the power supply must be connected to 1TB2-4 and neutral to 1TB2-11. The neutral must be the same polarity as ground. Units with improperly polarized control power will most likely display A00 and do nothing else. Units with no power on 1TB2-4 and 11 will usually alternately display Ed diagnostic (flow swt. interlock) and A100 (external stop).

Ed Diagnostic Chilled Water Flow Interlock

The Ed diagnostic is Machine Automatic Reset (MAR). The machine will restart when the interlock closes. Many users experience having to RESET the machine to get it to start with Ed diagnostic displayed as the LAST diagnostic code. The cause of the lockout is not the flow interlock but another manually resettable diagnostic that occurred before the flow interlock. This diagnostic can be obtained by searching the "C" diagnostic register. In these cases, the machine is locked off by the manual diagnostic and not noticed. The pump is stopped for night shut down and the Ed then becomes the LAST diagnostic. The user thinks the machine is being held off by the Ed and resets it and never finds the real cause. An interesting note: the Ed diagnostic will be displayed any time the machine is powered and the flow interlock circuit is open, even if the machine is in stop/reset position. This is to inform the user not to start or operate the machine because the interlock is open.

Disabling One Refrigeration Circuit

The proper way to disable one circuit on a dual circuit machine is to electrically disconnect the liquid line solenoid valve. Any other method will likely cause a latching diagnostic. The UCM performs a solenoid test before each startup if the test fails the circuit is locked out and the machine will operate on the one remaining circuit.

Operating One Compressor per Circuit

The only way to run just one compressor on a circuit is to activate the compressor KW limit by opening the circuit between TB1-1 and TB1-2 on the 1U1A1 board. This will allow the lead compressor only on each circuit to operate. The lag or 'B' and 'D' compressors cannot be operated alone. A single compressor on a circuit should not be operated if the other compressor on that circuit has failed in such a way to contaminate the system.

b5 or b6 Diagnostic Low Pressure Lockout

This diagnostic is displayed when the low pressure cutout is open for more than one minute or opens and closes more than 5 times while the respective refrigeration circuit is operating. The counter on the UCM for the 5 successive trips is only reset when the respective refrigeration circuit is turned off. A circuit operating for extended periods can experience 5 trips less than one minute in duration and not trip until the sixth low pressure switch opening.

C1, C2, C3, or C4 Diagnostic High Motor/Refrigerant Temperature

This diagnostic is displayed when the circuit is open to the respective compressor safety or if the circuit is grounded. Many servicers are jumping the pins on the UCM when this diagnostic is displayed and the condition will not clear. The proper procedure is to remove the wiring from the terminals, then check for an open and grounded circuit.

E6 Diagnostic Phase Reversal/Phase Loss at Power Up

The revision letter of the UCM software is displayed on the identification tag of the UCM along with the serial number and part number of the UCM. It will be displayed as Rev. C, etc.

On UCM's prior to revision 'D', the UCM monitored phase reversal/phase loss continually when powered. In revision 'D', the UCM software only checks the phase at power up (in the first two seconds) if the phasing is not correct the E6 diagnostic will stop the machine. It should be reset by power disconnection to the machine. Software prior to revision 'D', the E6 diagnostic was automatic reset. If the revision 'D' unit is reset at the UCM power switch, the unit will run and the display will flash 'E6'. Software revision 'E' must be reset by power disconnection to the unit. It cannot be reset at the UCM. The E6 diagnostic on the 'E' revision UCM can be disabled by placing dip switch SW3-5 in the ON position.

*Note: UCM's with REV. F or higher have mask chips, REV. B through E have replaceable EPROM'S.

E4 Diagnostic Phase Loss Running

If the high pressure switch is open at startup due to the internal timing of the UCM, you will get an E4 diagnostic.

*UCM Part Numbers

# on UCM	Part Number	<u>Application</u>
X1365-0346-01	PNL 9870	20-30 Ton with communications/reset board
X1365-0346-02	PNL 9871	40-60 Ton with communications/reset board
X1365-0346-03	PNL 9872	20-30 Ton without communications/reset board
X1365-0346-04	PNL 9873	40-60 Ton without communications/reset board

Remote Display Panel

X1365-0359-01 CPN 0182

* New Information

OVERVIEW

With the exception of the thermostats located in the motor windings and the discharge of the scroll compressors, all the temperature sensors used on the UCM are negative temperature coefficient (NTC) thermistors. The thermistors employed all have a base resistance of 10K ohms at 77°F and display a decreasing resistance with an increasing temperature. The UCM "reads" the temperature by measuring the voltage developed across the thermistors in a voltage divider arrangement with a fixed internal resistance. The value of this fixed resistance is different depending on the temperature range where the most accuracy is desired. The voltage source for this measurement is a closely regulated 10.0 VDC supply.

An open or shorted sensor will cause the UCM to indicate the appropriate diagnostic if the UCM dip-switch is configured to use the sensor. In the case of the evaporator water sensors, an open or short will always cause a diagnostic and it will result in a machine shutdown. All other temperature sensor diagnostics will result in the use of some default value for that parameter.

WARNING: To prevent injury or death due to electrical shock, use care when measurements, adjustments, or other service-related operations are performed with power on.

PROCEDURE

1. Measure the temperature at the sensor with an accurate thermometer; record the temperature reading observed.
2. With the sensor leads connected to the UCM and the UCM powered, measure the DC voltage across the sensor leads at the terminal or by probing the back of the MTA plug. It may be necessary to remove the cap over the top of the connector to gain access to the connector terminal.

Note: Always use a digital volt-ohmmeter with 10 megohm or greater input impedance to avoid "loading down" the voltage divider. Failure to do so will result in erroneously high temperature calculations.

3. Locate the appropriate sensor table. Table one, condenser entering and leaving water temperature. Table two, optional outdoor temperature. Table three, evaporator entering and leaving water, four, optional zone temperature. Then compare the temperature in the table corresponding to the voltage reading recorded in Step 2 with the actual temperature observed in Step 1.
If the actual temperature measured falls within the allowable tolerance range, both the sensor and the UCM's temperature input circuits are operating properly. However, if the actual temperature is outside the allowable sensor tolerance range, proceed to Step 4.
4. Again measure the temperature at the sensor with an accurate thermometer; record the temperature reading observed.
5. Remove the sensor leads from the terminal strip or unplug the respective MTA and measure the resistance of the sensor directly or by probing the MTA with a digital volt-ohmmeter. Record the resistance observed.
6. Select the appropriate sensor table and locate the resistance value recorded in Step 5. Verify that the temperature corresponding to this resistance value matches (i.e. within the tolerance range specified for that sensor) the temperature measured in Step 4.

If the sensor temperature is out of range, the problem is either with the sensor, wiring, or the MTA connector (if applicable). If an MTA connector is used and the thermistor reads open, first try cutting off the MTA, stripping a small amount of insulation from the sensor wire's end and repeating the measurement directly to the leads. Once the fault has been isolated in this manner, install a new sensor, reconnect the leads or both. When replacing a sensor it is easiest to cut the sensor wire near the MTA end and splice on a new sensor using wire nuts or soldering.

7. A decade box can be substituted for a sensor; and any sensor table value can be used to relate resistance to temperature. Remove the MTA plug and applying resistance to the proper pin terminals. The temperature as sensed by the UCM can be confirmed by using the service menu display mode, and scrolling to the display of the temperature of interest.

Note: All displayed temperatures are slew rate limited, rounded off to the nearest °F, and only accurate within a specified normal range. It is therefore important to be certain that the temperature readings are stable and that adequate time (up to 3.5 min. in the case of the zone sensor) is allowed after step changes in resistance inputs are made.

8. As the input boards are not serviceable, a problem with one of them would require a complete changeout of the UCM. The following test should be performed to assure that UCM replacement is necessary.
 - a. Check the power supply according to the information in Section 3.
 - b. Repeat the checkout procedure using a new sensor or decade box.

TABLE 1 SECTION ONE
 SENSOR CONVERSION DATA:
 CONDENSER ENTERING (4RT1) AND LEAVING (4RT2) WATER TEMPERATURE - CGW UNITS ONLY

Actual Temp. (F)	Actual Resistance (Ohms)	Thermistor Voltage (Note 3)	Actual Temp. (F)	Actual Resistance (Ohms)	Thermistor Voltage (Note 3)	Actual Temp. (F)	Actual Resistance (Ohms)	Thermistor Voltage (Note 3)
40.0	26220.8	7.197	70.0	11888.7	5.498	100.0	5824.3	3.809
41.0	25503.0	7.139	71.0	11595.6	5.439	101.0	5694.2	3.760
42.0	24807.5	7.090	72.0	11310.7	5.381	102.0	5567.4	3.701
43.0	24133.3	7.041	73.0	11033.7	5.322	103.0	5443.8	3.652
44.0	23479.7	6.982	74.0	10764.4	5.264	104.0	5323.3	3.604
45.0	22846.1	6.934	75.0	10502.6	5.205	105.0	5205.9	3.555
46.0	22231.9	6.875	76.0	10248.0	5.146	106.0	5091.5	3.506
47.0	21636.2	6.826	77.0	10000.4	5.088	107.0	4979.9	3.457
48.0	21058.7	6.768	78.0	9759.6	5.029	108.0	4871.1	3.408
49.0	20498.4	6.719	79.0	9525.4	4.971	109.0	4765.0	3.359
50.0	19955.0	6.660	80.0	9297.5	4.912	110.0	4661.5	3.311
51.0	19427.9	6.602	81.0	9075.9	4.854	111.0	4560.6	3.262
52.0	18916.5	6.553	82.0	8860.2	4.795	112.0	4462.2	3.223
53.0	18420.3	6.494	83.0	8650.4	4.736	113.0	4366.3	3.174
54.0	17938.8	6.436	84.0	8446.2	4.688	114.0	4272.6	3.125
55.0	17471.6	6.377	85.0	8247.5	4.629	115.0	4181.3	3.086
56.0	17018.0	6.318	86.0	8054.1	4.570	116.0	4092.2	3.037
57.0	16577.8	6.260	87.0	7865.8	4.512	117.0	4005.3	2.988
58.0	16150.5	6.201	88.0	7682.5	4.453	118.0	3920.5	2.949
59.0	15735.7	6.152	89.0	7504.2	4.404	119.0	3837.7	2.910
60.0	15332.9	6.094	90.0	7330.5	4.346	120.0	3756.9	2.861
61.0	14941.7	6.035	91.0	7161.4	4.287	121.0	3678.1	2.822
62.0	14561.9	5.977	92.0	6996.7	4.238	122.0	3601.1	2.783
63.0	14193.0	5.918	93.0	6836.3	4.180	123.0	3526.5	2.734
64.0	13834.6	5.859	94.0	6680.1	4.121	124.0	3453.6	2.695
65.0	13486.5	5.801	95.0	6528.0	4.072	125.0	3382.4	2.656
66.0	13148.3	5.742	96.0	6379.8	4.014	126.0	3313.0	2.617
67.0	12819.8	5.684	97.0	6235.5	3.965	127.0	3245.1	2.578
68.0	12500.5	5.615	98.0	6094.8	3.916	128.0	3178.9	2.539
69.0	12190.2	5.557	99.0	5957.8	3.857	129.0	3114.2	2.500

Notes:

1. Sensor 4RT1 is connected between Terminals TB1-5 and -6; 4RT2 is connected between Terminals TB1-7 and -8, both on board A1.
2. Overall accuracy for the condenser temperature sensors is $\pm 2 F^{\circ}$ over the range shown.
3. As you compare a thermistor resistance (or input voltage) reading with the "actual" temperature indicated by the thermometer, be sure to consider the precision of the thermometer when you decide whether or not the thermistor is out of range.
4. The thermistor resistances given do not account for the self-heating effects that are present when connected to the UCM. A connected "operating" thermistor will read a slightly lower (less than 1%) resistance

TABLE 2 SECTION ONE
 SENSOR CONVERSION DATA:
 OPTIONAL OUTDOOR TEMPERATURE (4RT3)

Actual Temp. (F)	Actual Resistance (Ohms)	Thermistor Voltage (Note 3)	Actual Temp. (F)	Actual Resistance (Ohms)	Thermistor Voltage (Note 3)	Actual Temp. (F)	Actual Resistance (Ohms)	Thermistor Voltage (Note 3)
-20.0	170040.3	8.652	30.0	34838.9	6.436	80.0	9297.5	3.408
-19.0	164313.4	8.633	31.0	33833.3	6.367	81.0	9075.9	3.359
-18.0	158796.5	8.604	32.0	32861.4	6.309	82.0	8860.2	3.311
-17.0	153482.9	8.574	33.0	31935.3	6.250	83.0	8650.4	3.252
-16.0	148365.0	8.545	34.0	31038.7	6.182	84.0	8446.2	3.203
-15.0	143432.2	8.516	35.0	30170.5	6.123	85.0	8247.5	3.154
-14.0	138679.6	8.486	36.0	29329.5	6.064	86.0	8054.1	3.105
-13.0	134098.6	8.457	37.0	28515.0	5.996	87.0	7865.8	3.057
-12.0	129684.9	8.428	38.0	27725.9	5.938	88.0	7682.5	3.008
-11.0	125428.5	8.389	39.0	26961.4	5.879	89.0	7504.2	2.959
-10.0	121326.1	8.359	40.0	26220.8	5.811	90.0	7330.5	2.910
-9.0	117369.6	8.320	41.0	25503.0	5.752	91.0	7161.4	2.871
-8.0	113554.9	8.291	42.0	24807.5	5.684	92.0	6996.7	2.822
-7.0	109876.5	8.252	43.0	24133.3	5.625	93.0	6836.3	2.773
-6.0	106328.1	8.223	44.0	23479.7	5.557	94.0	6680.1	2.734
-5.0	102904.9	8.184	45.0	22846.1	5.498	95.0	6528.0	2.686
-4.0	99602.3	8.145	46.0	22231.9	5.439	96.0	6379.8	2.637
-3.0	96416.1	8.105	47.0	21636.2	5.371	97.0	6235.5	2.598
-2.0	93341.6	8.066	48.0	21058.7	5.313	98.0	6094.8	2.559
-1.0	90374.2	8.027	49.0	20498.4	5.244	99.0	5957.8	2.510
0.0	87510.3	7.988	50.0	19955.0	5.186	100.0	5824.3	2.471
1.0	84745.9	7.949	51.0	19427.9	5.117	101.0	5694.2	2.432
2.0	82077.1	7.900	52.0	18916.5	5.059	102.0	5567.4	2.393
3.0	79500.5	7.861	53.0	18420.3	4.990	103.0	5443.8	2.354
4.0	77012.3	7.813	54.0	17938.8	4.932	104.0	5323.3	2.314
5.0	74609.7	7.773	55.0	17471.6	4.863	105.0	5205.9	2.275
6.0	72288.8	7.725	56.0	17018.0	4.805	106.0	5091.5	2.236
7.0	70047.4	7.686	57.0	16577.8	4.746	107.0	4979.9	2.197
8.0	67881.9	7.637	58.0	16150.5	4.678	108.0	4871.1	2.158
9.0	65790.2	7.588	59.0	15735.7	4.619	109.0	4765.0	2.129
10.0	63768.7	7.539	60.0	15332.9	4.561	110.0	4661.5	2.090
11.0	61815.3	7.490	61.0	14941.7	4.502	111.0	4560.6	2.051
12.0	59927.8	7.441	62.0	14561.9	4.434	112.0	4462.2	2.021
13.0	58103.1	7.393	63.0	14193.0	4.375	113.0	4366.3	1.982
14.0	56339.6	7.334	64.0	13834.6	4.316	114.0	4272.6	1.953
15.0	54634.7	7.285	65.0	13486.5	4.258	115.0	4181.3	1.914
16.0	52986.4	7.236	66.0	13148.3	4.199	116.0	4092.2	1.885
17.0	51392.6	7.178	67.0	12819.8	4.141	117.0	4005.3	1.855
18.0	49851.6	7.129	68.0	12500.5	4.082	118.0	3920.5	1.816
19.0	48360.9	7.070	69.0	12190.2	4.023	119.0	3837.7	1.787
20.0	46919.2	7.012	70.0	11888.7	3.965	120.0	3756.9	1.758
21.0	45524.6	6.963	71.0	11595.6	3.906	121.0	3678.1	1.729
22.0	44175.6	6.904	72.0	11310.7	3.848	122.0	3601.1	1.699
23.0	42870.3	6.846	73.0	11033.7	3.789	123.0	3526.5	1.670
24.0	41607.6	6.787	74.0	10764.4	3.740	124.0	3453.6	1.641
25.0	40385.3	6.729	75.0	10502.6	3.682	125.0	3382.4	1.611
26.0	39202.7	6.670	76.0	10248.0	3.623	126.0	3313.0	1.582
27.0	38057.9	6.611	77.0	10000.4	3.574	127.0	3245.1	1.563
28.0	36950.0	6.553	78.0	9759.6	3.516	128.0	3178.9	1.533
29.0	35877.4	6.494	79.0	9525.4	3.467	129.0	3114.2	1.504
						130.0	3051.0	1.484

Notes:

1. Sensor 4RT3 is connected between Terminals TB1-9 and -10 on board A1.
2. Overall accuracy for the outdoor ambient temperature sensor is $\pm 2 F^{\circ}$ over the range shown.
3. As you compare a thermistor resistance (or input voltage) reading with the "actual" temperature indicated by the thermometer, be sure to consider the precision of the thermometer when you decide whether or not the thermistor is out of range.

TABLE 3 SECTION ONE

SENSOR CONVERSION DATA:

EVAPORATOR ENTERING (4RT4) AND LEAVING (4RT5) WATER TEMPERATURE

SEN205 come as a matched pair (4RT4 and 4RT5) only.

Actual Temp. (F)	Actual Resistance (Ohms)	Thermistor Voltage (Note 3)	Actual Temp. (F)	Actual Resistance (Ohms)	Thermistor Voltage (Note 3)	Actual Temp. (F)	Actual Resistance (Ohms)	Thermistor Voltage (Note 3)
-15.0	143432.2	8.057	25.0	40385.3	5.928	65.0	13486.5	3.418
-14.0	138679.6	8.018	26.0	39202.7	5.859	66.0	13148.3	3.369
-13.0	134098.6	7.979	27.0	38057.9	5.791	67.0	12819.8	3.311
-12.0	129684.9	7.939	28.0	36950.0	5.732	68.0	12500.5	3.262
-11.0	125428.5	7.891	29.0	35877.4	5.664	69.0	12190.2	3.203
-10.0	121326.1	7.852	30.0	34838.9	5.596	70.0	11888.7	3.154
-9.0	117369.6	7.813	31.0	33833.3	5.527	71.0	11595.6	3.096
-8.0	113554.9	7.764	32.0	32861.4	5.459	72.0	11310.7	3.047
-7.0	109876.5	7.725	33.0	31935.3	5.400	73.0	11033.7	2.998
-6.0	106328.1	7.676	34.0	31038.7	5.332	74.0	10764.4	2.949
-5.0	102904.9	7.627	35.0	30170.5	5.264	75.0	10502.6	2.900
-4.0	99602.3	7.588	36.0	29329.5	5.205	76.0	10248.0	2.852
-3.0	96416.1	7.539	37.0	28515.0	5.137	77.0	10000.4	2.803
-2.0	93341.6	7.490	38.0	27725.9	5.068	78.0	9759.6	2.754
-1.0	90374.2	7.441	39.0	26961.4	5.010	79.0	9525.4	2.705
0.0	87510.3	7.393	40.0	26220.8	4.941	80.0	9297.5	2.666
1.0	84745.9	7.334	41.0	25503.0	4.873	81.0	9075.9	2.617
2.0	82077.1	7.285	42.0	24807.5	4.814	82.0	8860.2	2.568
3.0	79500.5	7.236	43.0	24133.3	4.746	83.0	8650.4	2.529
4.0	77012.3	7.178	44.0	23479.7	4.688	84.0	8446.2	2.480
5.0	74609.7	7.129	45.0	22846.1	4.619	85.0	8247.5	2.441
6.0	72288.8	7.070	46.0	22231.9	4.561	86.0	8054.1	2.393
7.0	70047.4	7.021	47.0	21636.2	4.492	87.0	7865.8	2.354
8.0	67881.9	6.963	48.0	21058.7	4.434	88.0	7682.5	2.314
9.0	65790.2	6.904	49.0	20498.4	4.365	89.0	7504.2	2.275
10.0	63768.7	6.846	50.0	19955.0	4.307	90.0	7330.5	2.236
11.0	61815.3	6.787	51.0	19427.9	4.238	91.0	7161.4	2.197
12.0	59927.8	6.729	52.0	18916.5	4.180	92.0	6996.7	2.158
13.0	58103.1	6.670	53.0	18420.3	4.121	93.0	6836.3	2.119
14.0	56339.6	6.611	54.0	17938.8	4.063	94.0	6680.1	2.080
15.0	54634.7	6.553	55.0	17471.6	3.994	95.0	6528.0	2.041
16.0	52986.4	6.494	56.0	17018.0	3.936	96.0	6379.8	2.002
17.0	51392.6	6.436	57.0	16577.8	3.877	97.0	6235.5	1.973
18.0	49851.6	6.367	58.0	16150.5	3.818	98.0	6094.8	1.934
19.0	48360.9	6.309	59.0	15735.7	3.760	99.0	5957.8	1.904
20.0	46919.2	6.240	60.0	15332.9	3.701	100.0	5824.3	1.865
21.0	45524.6	6.182	61.0	14941.7	3.643	101.0	5694.2	1.836
22.0	44175.6	6.113	62.0	14561.9	3.584	102.0	5567.4	1.797
23.0	42870.3	6.055	63.0	14193.0	3.535	103.0	5443.8	1.768
24.0	41607.6	5.986	64.0	13834.6	3.477	104.0	5323.3	1.738

Notes:

1. Sensor 4RT4 is connected between Terminals J1-5 and -4; 4RT5 is connected between Terminals J1-2 and -1, both on board A1.
2. Overall accuracy for the evaporator temperature sensors is $\pm 1.5^\circ\text{F}$ over the range of 30°F to 60°F and $+ 2^\circ\text{F}$ over the remaining range shown.
3. As you compare a thermistor resistance (or input voltage) reading with the "actual" temperature indicated by the thermometer, be sure to consider the precision of the thermometer when you decide whether or not the thermistor is out of range.
4. The thermistor resistances given do not account for the self-heating effects that are present when connected to the UCM. A connected "operating" thermistor will read a slightly lower (less than 1%) resistance

TABLE 4 SECTION ONE
 SENSOR CONVERSION DATA:
 OPTIONAL ZONE TEMPERATURE (4RT12)

Actual Temp. (F)	Actual Resistance (Ohms)	Thermistor Voltage (Note 3)	Actual Temp. (F)	Actual Resistance (Ohms)	Thermistor Voltage (Note 3)	Actual Temp. (F)	Actual Resistance (Ohms)	Thermistor Voltage (Note 3)
10.0	63768.7	4.063	55.0	17471.6	2.910	100.0	5824.3	1.621
11.0	61815.3	4.043	56.0	17018.0	2.871	101.0	5694.2	1.602
12.0	59927.8	4.023	57.0	16577.8	2.832	102.0	5567.4	1.582
13.0	58103.1	4.004	58.0	16150.5	2.813	103.0	5443.8	1.543
14.0	56339.6	3.984	59.0	15735.7	2.773	104.0	5323.3	1.523
15.0	54634.7	3.965	60.0	15332.9	2.754	105.0	5205.9	1.504
16.0	52986.4	3.945	61.0	14941.7	2.715	106.0	5091.5	1.484
17.0	51392.6	3.926	62.0	14561.9	2.695	107.0	4979.9	1.465
18.0	49851.6	3.906	63.0	14193.0	2.656	108.0	4871.1	1.426
19.0	48360.9	3.867	64.0	13834.6	2.637	109.0	4765.0	1.406
20.0	46919.2	3.848	65.0	13486.5	2.598	110.0	4661.5	1.387
21.0	45524.6	3.828	66.0	13148.3	2.559	111.0	4560.6	1.367
22.0	44175.6	3.809	67.0	12819.8	2.539	112.0	4462.2	1.348
23.0	42870.3	3.789	68.0	12500.5	2.500	113.0	4366.3	1.328
24.0	41607.6	3.770	69.0	12190.2	2.480	114.0	4272.6	1.309
25.0	40385.3	3.730	70.0	11888.7	2.441	115.0	4181.3	1.289
26.0	39202.7	3.711	71.0	11595.6	2.422	116.0	4092.2	1.270
27.0	38057.9	3.691	72.0	11310.7	2.383	117.0	4005.3	1.250
28.0	36950.0	3.652	73.0	11033.7	2.363	118.0	3920.5	1.230
29.0	35877.4	3.633	74.0	10764.4	2.324	119.0	3837.7	1.211
30.0	34838.9	3.613	75.0	10502.6	2.305	120.0	3756.9	1.191
31.0	33833.3	3.594	76.0	10248.0	2.266	121.0	3678.1	1.172
32.0	32861.4	3.555	77.0	10000.4	2.246	122.0	3601.1	1.152
33.0	31935.3	3.535	78.0	9759.6	2.207	123.0	3526.5	1.133
34.0	31038.7	3.496	79.0	9525.4	2.188	124.0	3453.6	1.113
35.0	30170.5	3.477	80.0	9297.5	2.148	125.0	3382.4	1.094
36.0	29329.5	3.457	81.0	9075.9	2.129	126.0	3313.0	1.074
37.0	28515.0	3.418	82.0	8860.2	2.090	127.0	3245.1	1.055
38.0	27725.9	3.398	83.0	8650.4	2.070	128.0	3178.9	1.035
39.0	26961.4	3.359	84.0	8446.2	2.051	129.0	3114.2	1.035
40.0	26220.8	3.340	85.0	8247.5	2.012	130.0	3051.0	1.016
41.0	25503.0	3.320	86.0	8054.1	1.992	131.0	2989.2	0.996
42.0	24807.5	3.281	87.0	7865.8	1.953	132.0	2928.9	0.977
43.0	24133.3	3.262	88.0	7682.5	1.934	133.0	2870.0	0.957
44.0	23479.7	3.223	89.0	7504.2	1.895	134.0	2812.4	0.957
45.0	22846.1	3.203	90.0	7330.5	1.875	135.0	2756.2	0.938
46.0	22231.9	3.164	91.0	7161.4	1.855	136.0	2701.2	0.918
47.0	21636.2	3.145	92.0	6996.7	1.816	137.0	2647.5	0.898
48.0	21058.7	3.105	93.0	6836.3	1.797	138.0	2595.0	0.879
49.0	20498.4	3.086	94.0	6680.1	1.777	139.0	2543.7	0.879
50.0	19955.0	3.047	95.0	6528.0	1.738	140.0	2493.6	0.859
51.0	19427.9	3.027	96.0	6379.8	1.719	141.0	2444.6	0.840
52.0	18916.5	2.988	97.0	6235.5	1.699	142.0	2396.7	0.840
53.0	18420.3	2.969	98.0	6094.8	1.680	143.0	2349.9	0.820
54.0	17938.8	2.930	99.0	5957.8	1.641	144.0	2304.1	0.801

Notes:

1. Sensor 4RT12 is connected between Terminals TB1-1 and -2 on board A5 (communications).
2. Overall accuracy for the zone temperature sensor is $\pm 2 F^{\circ}$ over the range shown.
3. As you compare a thermistor resistance (or input voltage) reading with the "actual" temperature indicated by the thermometer, be sure to consider the precision of the thermometer when you decide whether or not the thermistor is out of specified accuracy.
4. The thermistor resistances given do not account for the self-heating effects that are present when connected to the UCM. A connected "operating" thermistor will read a slightly lower (less than 1%) resistance

SECTION 2 CURRENT TRANSFORMER CHECKOUT PROCEDURE

OVERVIEW

Each compressor motor has two of its three line currents monitored by doughnut current transformers. While the UCM utilizes both of the signals, it only displays one of the two line currents monitored per compressor (phase A for compressors A,B, and D, and phase B for compressor C). These currents are normalized with respect to the Rated Load Amps of the respective compressor and thus are expressed in terms of % (PERCENT) RLA. In general, the current transformers provide the input for three basic functions of the UCM;

1. Motor overload protection using a programmed "% RLA versus time to trip" characteristic. In general, the steady state "must trip" value is 140% RLA and the "must hold" value is 125% RLA. Overload trips are displayed as diagnostic codes bA, bb, bC and bd and they will result in respective refrigeration circuit shutdowns.
2. Verifying contactor drop-out. If currents corresponding to less than 15 + or -5% RLA (currents this low are displayed as 0) are not detected on both of the monitored compressor phases within approximately 1 second after an attempted contactor drop-out, the UCM will attempt a shutdown of the other compressor of the refrigeration circuit (if energized) and display the appropriate contactor failure diagnostic code CA, Cb, CC, or Cd.
3. Loss of phase while running protection. If the detection of any or all of the three motor phase currents falls below 15 + or -5% RLA for 2 + or -1 seconds while the branch circuit should be "energized", the UCM will shutdown the entire machine and display a diagnostic code of E4. Failure of a contactor to pull in will also cause this diagnostic.

Note: Phase Reversal/Phase Loss on Power Up (diagnostic code E6) is sensed through incoming low voltage power to the UCM. Refer to Section 3 Power Supply Checkout Procedure. The current transformers are NOT polarity or directional sensitive.

A failure associated with the current transformers, terminators, or input circuitry could cause a CA, Cb, CC, or Cd diagnostics. These same diagnostics might also signify compressor, contactor, or incoming power problems and these problems should be checked out first.

WARNING: To prevent injury or death due to electrical shock, use care when measurements, adjustments, or other service-related operations are performed with power on.

Procedure

1. Verify that proper phase and line voltages are present at each contactor, the voltage must be within 10% of nominal and phase imbalance is less than 2%. Certain units have dual voltage ratings, it is important to verify for which nominal voltage the unit has been wired. This is most easily accomplished by checking the wiring to the 1T2 and 1T12 control transformer while referencing the unit schematic to determine which tap of these transformers have been utilized.
2. Check the UCM for all of the presently stored diagnostic codes to narrow the problem down to a particular compressor or contactor as noted above. Write down all of the diagnostic codes stored in the "B" and "C" registers as certain resets or the removal of UCM power in Step 4 will clear the diagnostic registers.
3. If the diagnostic is "Phase Loss (Running)" an attempt should be made to reset the UCM and restart the chiller to observe compressor staging. Usually the shutdown and diagnostic will appear approximately 3 seconds after the attempted pull-in of the offending circuit. Refer to operational literature for sequence on starting and staging the compressors.

4. For the next portion of the procedure, you must pull the unit's disconnect and interrupt all high voltage power to the control panel. Locate the doughnut current transformers encircling the power wiring just below the compressor contactors of the suspect circuit in the control panel. Refer to the Component Location Drawing in the panel to identify the particular transformer(s) of interest. Locate the part number/UL tag on the transformer leads and note the Trane part number which identifies the transformers.

Note: All compressors of a given tonnage should have the same transformer extension number. Verify the proper transformer using Tables 1 and 2 in this section.

5. Utilizing the Schematic Wiring Diagram, locate the termination of the transformer's wiring into the MTA plug at the UCM. Pull off the appropriate MTA connector from the pin header on the UCM.
6. Using a digital volt-ohmmeter, measure the resistance of the transformer(s) by proving the appropriate pair(s) of receptacles within the MTA. The receptacle pairs of the MTA are most easily measured by using meter leads with pointed probes and contacting the exposed metal of the connector through either the top or the side of the MTA. It may be necessary to remove a cap over the top of the connector to gain access to the connector terminal.
7. Refer to Table 1, Section 2 which lists the normal resistance range for each extension of current transformer. Check the measured resistance against the value listed per transformer extension. If the resistance is within tolerance the transformer and MTA can be considered good. Go on to step 9.
8. If the resistance reading of Step 6 is out of tolerance, the problem is either with the transformer, it's wiring, or the MTA connector. First double check the schematic to be sure you are working the proper lead pair, then cut the leads to the particular transformer near the MTA connector and repeat the resistance measurement by stripping insulation from the wire's end. Once the fault has been isolated in this manner, repair the wire/connector or install a new transformer as necessary.

As more than one current transformer is terminated to a single MTA, when repairing the MTA take care to note the proper positions of the respective transformer wire terminations on the MTA for the re-termination. NOTE: The current transformers are NOT polarity or directional sensitive. If the fault can be isolated to the current transformer or its wiring apart from the connector, the connector can be reused by cutting off the bad transformer and splicing in a new transformer using wire nuts.

9. If the transformer/connector resistance proves accurate, recheck the resistance with the connector held at different angles and with a light lead pull (less than 5 lb.) to test for an intermittent condition.
10. With the transformer disconnected and the power off measure the resistance of the respective pin pair(s) at the UCM. The input resistance should read approximately 150 ohms + or - 2 ohms for each current transformer UCM input. Extreme errors suggest a defective UCM Micro-Module, be sure to consider the accuracy of your volt-ohmmeter before replacing the UCM. If the input resistances prove accurate, reconnect the transformers to the UCM and repower the unit.

WARNING: Use extreme care when performing this checkout procedure while the chiller is energized. Carelessness can result in injury or death.

11. With the CT's reconnected to the UCM, attempt a restart of the chiller. As the given compressor is started, simultaneously monitor the actual compressor phase current(s) (using a clamp on type amprobe) and the voltage developed at the respective current transformer's termination at the UCM (using a digital volt-meter on a 0-20 VAC scale). Refer to Section 4 for tips on Chiller staging procedures. If the phase current is also one of the currents that are displayed by the UCM, scroll to that display and compare it with the measure values. Remember that only phase A of compressors A, B and D and phase B of compressor C are displayed and that they are expressed in terms of %RLA, (not amps). The following equation relates the two measurements and the displayed value:

$$\frac{V_m \times A_{tr}}{4.33 \times PT} = A_m = \%RLA_{ucm} \times RLAc$$

- V_m** is the current transformer's output voltage at the UCM in Volts rms.
- A_{tr}** is the rated amps of the current transformer (refer to Table 1).
- PT** is the primary turns thru the CT (usually one).
- A_m** is the measured motor phase amperage in Amps rms.
- %RLA_{ucm}** is UCM displayed value (if applicable).
- RLAc** is the unit's nameplate rating of Running Load Amps for the given compressor.

The preceding quotation only applies during steady state current draws of between 50 to 200% of the CT rating. (Inrush transient currents and associated CT output voltages can be expected to be from 3 to 6 times the steady state values, and the displayed value only reads up to 255% RLA). The accuracy of the displayed value should be within + or - 5%, and the accuracy of the CT voltage output should be within + or - 3% of the actual measured current over the range.

12. If the measured current and the output voltage from the CT agree within the tolerance specified, the CT is good. If diagnostics and trips continue to occur with all phase currents to the compressors verified to be within their normal range, then the problem is either with the CT selection, Micro-module dip switch settings, or UCM itself.

Refer to Table 2, Section 2 for data to verify CT selection and Micro-module dip switch setting. Once the dip switch settings and the current transformer part numbers have been verified, UCM replacement is indicated, however a UCM power supply check per Section 3 must be performed.

13. If the measured current and the CT output voltage do not agree, then the current transformer should be changed out per Step 8 above.
14. If no phase currents are measured with the amprobe on any or all of the legs to a given compressor immediately following the attempted staging of that compressor by the UCM, the problem lies either with the contactor, motor circuit, or UCM Relay Output Board(s). Refer to Relay Board Checkout Procedure of Section 4.

Normally one can determine when the UCM has attempted to add a stage by observing the operating code (codes with the "A" prefix). The display will update the operating status within 1.5 seconds of an attempted stage. It will not indicate, however, which compressor was staged. In the event of a diagnostic, a shutdown may occur and the operating code will be "frozen" to indicate the last operational code attempted just before a shutdown.

TABLE 1 SECTION TWO.

CURRENT TRANSFORMER RESISTANCE DATA:

CURRENT TRANSFORMERS (1T3 THRU 1T6) (40 TON AND UP: 1T3 THRU 1T10)

MNEUMONIC PART	TRANS PART NO.	RATED CURRENT	RESISTANCE RANGE (OHMS)
TRR 580	X13580050-01	25 ARMS	17.0 TO 22.0
TRR 581	X13580050-02	30 ARMS	22.0 TO 29.5
TRR 582	X13580050-03	40 ARMS	29.5 TO 35.0
TRR 583	X13580050-04	45 ARMS	35.0 TO 45.0
TRR 584	X13580050-05	60 ARMS	45.0 TO 60.0
TRR 585	X13580050-06	75 ARMS	60.0 TO 76.0
TRR 586	X13580050-07	95 ARMS	76.0 TO 100.0
TRR 587	X13580050-08	125 ARMS	103.0 TO 141.0
TRR 588	X13580050-09	180 ARMS	160.0 TO 205.0

TABLE 2. SECTION TWO

CURRENT TRANSFORMER SELECTION AND OVERLOAD DIP SWITCH SETUP
UNIT CONTROL MODULE 1U1A3 (MICRO DISPLAY BOARD)

Air-Cooled Chillers

Comp Tons	Nom Volts	Nom FLA	FLA Set	Must Hold	Must Trip	CT Ext	Prim. Turns	Max Prim Wire Size	SWS 10 Ton Switch	SW4 15 Ton Switch
10	200/230	39.4	39.3	49.3	55.1	-05	1	10	10101	-----
10	460	17.2	17.1	21.5	24.1	-01	1	12	11000	-----
10	575	13.2	13.2	16.5	18.6	-01	1	12	00011	-----
15	200/230	56.0	55.5	70.0	78.4	-07	1	4	-----	01100
15	460	23.5	23.5	29.4	33.0	-04	1	10	-----	00010
15	575	18.7	18.6	23.4	26.2	-02	1	10	-----	10001

Note: Switch settings for dip switches SW4 & SW5 (1="On", 0="Off") are given in ascending order by element position (elements positions are labeled from 1 to 5, from top to bottom, on each dipswitch).

Water-Cooled Chillers

Comp Tons	Nom Volts	Nom FLA	FLA Set	Must Hold	Must Trip	CT Ext	Prim. Turns	Max Prim Wire Size	SWS 10 Ton Switch	SW4 15 Ton Switch
10	200/230	34.0	33.8	42.3	47.3	05	1	6	01001	-----
	380	17.0	16.9	21.1	23.7	02	1	8	01001	-----
	460	14.0	13.9	17.4	19.5	01	1	8	01000	-----
	575	13.0	12.8	16.0	17.9	01	1	12	00000	-----
	363	15.0	15.0	18.8	21.0	01	1	8	01110	-----
	400	14.0	13.9	17.4	19.5	01	1	12	01000	-----
15	200/230	52.0	51.7	64.6	72.4	07	1	6	-----	00110
	380	27.0	26.9	33.6	37.7	04	1	8	-----	01110
	460	23.0	23.0	28.8	32.2	04	1	8	-----	00000
	575	18.0	18.0	22.5	25.2	02	1	8	-----	01110
	363	25.0	24.8	31.0	34.7	04	1	8	-----	00111
	400	22.0	22.0	27.1	30.4	02	1	10	-----	11101

Note: Switch settings for dip switches SW4 & SW5 (1="On", 0="Off") are given in ascending order by element position (elements positions are labeled from 1 to 5, from top to bottom, on each dipswitch).

TABLE 2 CONTINUED: SECTION TWO

Compressor Chillers

Comp Tons	Nom Volts	Nom FLA	FLA Set	Must Hold	Must Trip	CT Ext	Prim. Turns	Max Prim Wire Size	SW5 10 Ton Switch	SW4 15 Ton Switch
10	220/230	39.0	38.8	48.5	54.3	05	1	6	10100	-----
	380	20.0	19.9	24.9	27.9	02	1	8	10110	-----
	460	17.0	16.9	21.1	23.7	02	1	8	01001	-----
	575	14.0	13.9	17.4	19.5	01	1	8	01000	-----
	363	19.0	18.9	23.6	26.5	02	1	8	10010	-----
	400	17.0	16.9	21.1	23.7	02	1	8	01001	-----
15	200/230	58.0	57.6	72.0	80.6	07	1	4	-----	01111
	380	31.0	30.9	38.6	43.3	05	1	8	-----	00001
	460	26.0	26.0	32.5	36.4	04	1	8	-----	01011
	575	21.0	20.8	26.0	29.1	02	1	8	-----	11001
	363	28.0	28.0	35.0	39.2	04	1	8	-----	10001
	400	25.0	24.8	31.0	34.7	04	1	8	-----	00111

Note: Switch settings for dip switches SW4 & SW5 (1="On", 0="Off") are given in ascending order by element position (elements positions are labeled from 1 to 5, from top to bottom, on each dipswitch).

COMPRESSOR SELECTION TABLE

SW1 must also be set to identify compressors. It has four positions (position 1 through 4) for compressors A through D, respectively. "Off" for each position signifies a 10 ton compressor, "On" signifies a 15 ton compressor. SW1, SW4, and SW5 are on Assembly A3.

Unit Size	SW1 - Position			
	1	2	3	4
20T	Off	Off	Off	Off
25T	On	Off	Off	Off
30T	On	On	Off	Off
40T	Off	Off	Off	Off
50T	On	Off	On	Off
60T	On	On	On	On

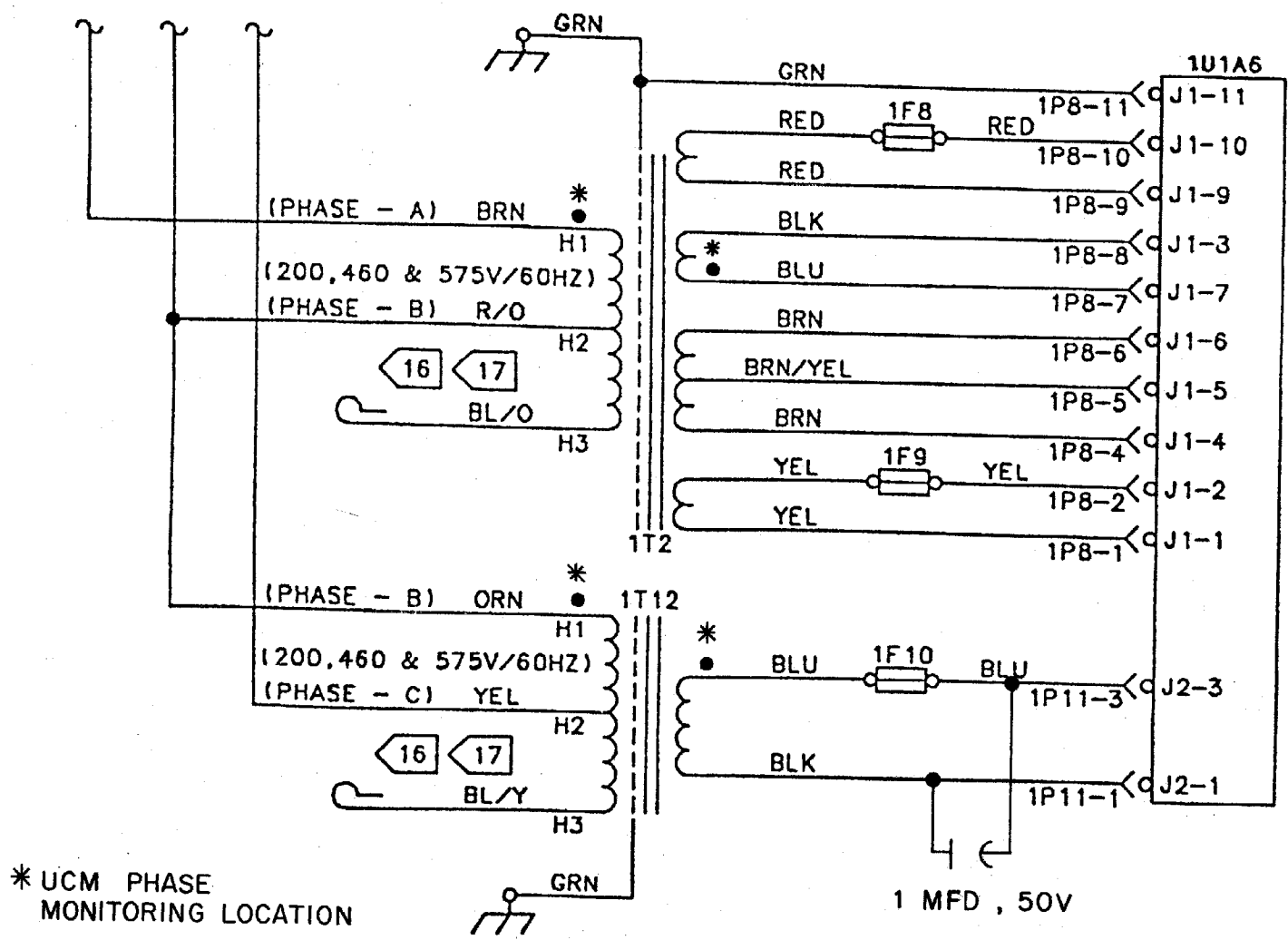

FIGURE B

SECTION 3 POWER SUPPLY CHECKOUT PROCEDURE

OVERVIEW

The Unit Control Module (UCM) power supply consists of two, line to low voltage, multiple secondary transformers (1T2 and 1T12) located externally to the UCM enclosure, and a Power Supply Board (A6) located internal to the UCM. The Power Supply Board is a serviceable board within the UCM subbase and can easily be accessed and replaced if necessary, without disconnecting or interfering with other unassociated connections to the UCM. The transformers have both of their primary legs fused and certain windings of their secondaries fused externally, while both have internal non-serviceable thermal fuses. Refer to the unit schematic wiring diagram for details.

Transformer 1T2, the larger of the two transformers, provides low voltage power for all of the UCM logic, analog to digital conversion, on board relay drives, vacuum fluorescent display, and phase rotation information. Transformer 1T12 provides low voltage power for the DC "pump down" solenoid valves and phase rotation information. The power supply board is connected to both of these transformers via plug-on connectors. Some model extensions of the transformers are dual input voltage type with an additional primary lead.

The functions handled by the power supply board include DC rectification, voltage regulation, pump down solenoid valve switching, phase rotation detection, (see Figure B) and high-low line voltage detection.

The UCM may be able to display diagnostic codes despite certain problems in the power supply. Diagnostic codes that infer incoming line voltage problems or power supply problems include:

<u>CODE</u>	<u>DESCRIPTION</u>	<u>POSSIBLE CAUSES</u>
82	Solenoid Valve #1	Bad coil or open circuit to valves; bad transformer; or fuses (1T12); bad A6 board.
83	Solenoid Valve #2	
d7	Over Voltage (line)	Excessive line voltage or bad A6 board nominal line +20% trip; +18% reset or 1T2 and 1T12 miswired to low voltage taps.
d8	Under Voltage (line)	Low line voltage; bad transformer 1T2; or bad A6 board. Nominal -18% trip; -14% reset or 1T2 and 1T12 miswired to high voltage taps.
E6	Phase Reversal/Loss	Bad transformer fuses; incoming power phasing; extreme noise on line caused by DC drives, etc.; bad A6 board.
Fd	External Interlock (open)	Loss of +18 half wave to external interlock input circuitry; bad external contact or wiring.
NO DISPLAY		Line voltage; bad transformers or fuses. Bad A6 board; bad Micro-module.

NOTE: It is a good practice to check the power supply components whenever troubleshooting the UCM. An improper voltage input to A6 can cause a good UCM to malfunction. The steps below should usually be done in order to check the entire power supply.

- * The E6 diagnostic can be caused by severe conducted noise on the incoming three phase power to the chiller. Such noise can be generated by large horsepower DC drives or SCR motor controls on the same power circuit as the chiller. A noise suppression capacitor added across the secondary leads of transformer 1T12 can significantly reduce the noise to the UCM to prevent nuisance trips. The capacitor should be a general purpose metalized polyester type for AC application, valued at between 1 to 10 micro farad (non polarized) with a rating of 50 WVDC or higher. Radio Shack part number 272-1055 or 272-996; see Figure B.

PROCEDURE

Power Transformer (1T2) Checkout

1. Check line voltage branch circuit fuses to the transformer for continuity.
2. Check the two secondary fuses between the transformer and UCM for continuity.
3. Apply power to the chiller and place the UCM in the STOP/RESET mode. Confirm that line voltage is available at the transformers primary lead terminations and that the proper colored leads are used. Note the value of the line voltage for later procedures. Refer to the schematic for lead color coding to verify that proper phasing and that the correct primary taps have been wired for the existing line voltage (applicable to dual primary voltage transformers only).
4. With the connector plug still in place on pin header J1 of Power Supply Board A6, see Figure C, measure the AC voltage on the pin pairs as noted in Table 1, Section 3. Note that the pins are labeled from 11 (top) to 1 (bottom). The pins can be probed by contacting the exposed metal of each position at the top of the MTA. It may be necessary to remove the sliding cover over the MTA's top, if present, to gain access to the connector terminal.
5. If any of the windings output voltages fall outside of the range given, first verify the primary line voltage, as measured in step 3 above, is within the range of +10 to -15% of nominal. Next unplug the transformer connector from the power supply board and remeasure the winding output voltages unloaded. If they still fall out of range, recheck the secondary fuses and then replace the transformer.
6. If the windings fall out of range only when the transformer is connected to the UCM, refer to the Power Supply Board Checkout Procedure.

POWER TRANSFORMER (1T12) CHECKOUT

1. Check line voltage branch circuit fuses to the transformer for continuity.
2. Check the secondary fuse between the transformer and UCM for continuity.
3. Apply power to the chiller and place the UCM in the STOP/RESET mode. Confirm that line voltage is available at the transformers primary lead terminations and that the proper colored leads are used. Note the value of the line voltage for later procedures. Refer to the schematic for lead color coding to verify that proper phasing and that the correct primary taps have been wired for the existing line voltage (for dual voltage types).
4. With the connector plug still in place on pin header J2 of board A6, measure the AC voltage on the pin pair as noted in Table 2, Section Three. Note that the pins are labeled from 3 (top) to 1 (bottom). The pins can be probed by contacting the exposed metal of each position at the top of the MTA.
5. If the measured voltage falls outside of the range given, first verify that the primary line voltage, as measured in step 3 above, is within the range of + or -10% of nominal. Next unplug the transformer connector from the power supply board A6 of the UCM and remeasure the winding output voltage unloaded. If it still falls out of range, recheck the secondary fuse and then replace the transformer.
6. If the winding's voltage falls out of range only when the transformer is connected to the UCM, refer to the Power Supply Board Checkout Procedure Part B: Pump Down Solenoid Valve Output.

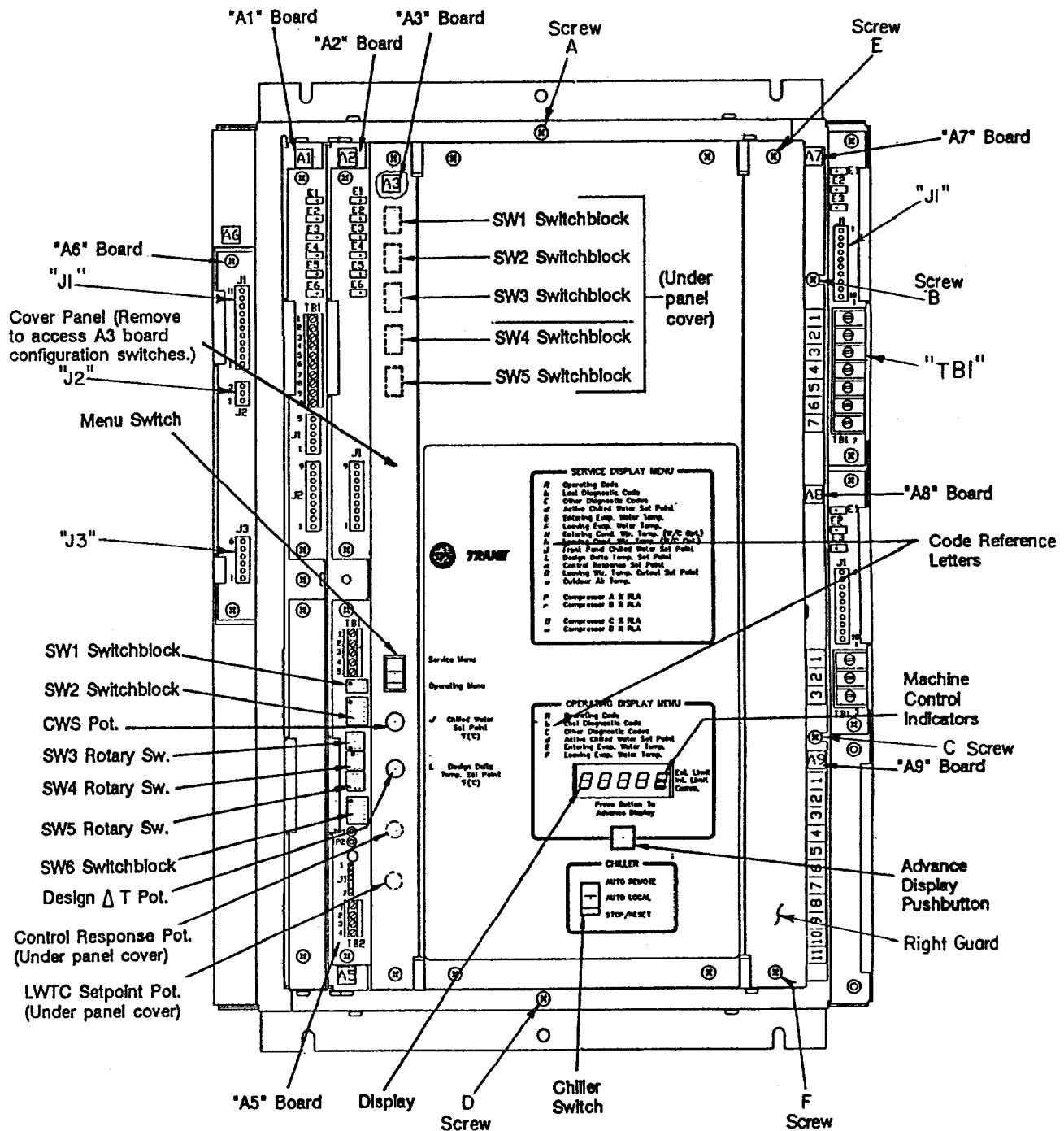

FIGURE "C"

POWER SUPPLY BOARD (A6) CHECKOUT

Part A: Power Supply to UCM

1. Place the UCM in the STOP/RESET mode and DISCONNECT all power to the chiller.
2. **Caution:** Static sensitive components are exposed during this procedure. Service personnel must use a wrist grounding strap. Also the tools used shall be grounded through momentary contact with the module chassis prior to any servicing.
3. Remove screws A, B, C and D (see Figure C) attaching the top portion of the Micro-module to the bottom portion (subbase) of the UCM and carefully swing open the Micro-module on its left side "hinge" to expose the boards within the subbase. Locate the power supply board (A6) in the upper left hand corner. Just to the right of where the ribbon cable from the micro-module attaches to the board (at jack J4) locate 15 test points numbered 1 thru 16 (TP7 not included). **Note:** Some versions of the power supply board do not have test point pads. The voltages must be read by probing exposed pins of the ribbon cable connector.
4. Power up the UCM in the STOP/RESET mode and carefully probe the test point pads with a digital volt-ohmmeter and compare the measured voltage to the values in Table 3, Section 3. If any of the voltages measured are out of range go to step 6. If all the voltages are within the range specified, it may be necessary to repeat this test under actual running conditions as described in step 5 following.
5. Since loads on certain of the voltage supplies change as the UCM stages the chiller and since many power supply problems are heat (load) related, it may be advisable to observe the voltages during the time when the problems are exhibited, if possible. To accomplish this, it is necessary to place the UCM in the AUTO LOCAL mode, adjust the set point for a cooling demand, and to satisfy all interlocks for normal compressor staging. Remeasure the voltage levels once the Chiller is fully loaded and the power supply has had some time to warm. If all the voltages are still within the range specified, the power supply board and the associated power transformers can be assumed to be good. Refer to troubleshooting procedures for other UCM boards, and components if problems persist.
6. If any of the measured voltages fall outside of the ranges given, first disconnect all line voltages from the UCM. Then unplug the ribbon cable connecting the power supply board (A6) to the Micro-Display Board (A3) of the Micro-module at Jack J4. Power up the UCM and place in the STOP/RESET mode. Remeasure the unloaded test point voltages. If the measured values still fall outside of the range, the power supply board should be replaced (assuming the power transformers have been fully checked out per the steps above). Even if the values return to normal, the Power Supply Board may still be at fault. Go on to the Pump Down SOlenoid Valve Output procedure and the Relay and Options Output Board Checkout Procedures to verify their proper operation prior to any power supply board change out.

Page B: Pump Down Solenoid Valve Output(s)

Note: This output and the associated solenoid valve's coil are designed for 12 VDC. When servicing the coil, the direct replacement parts (valve and coil), must be used to ensure proper operation. Verify that the coil is stamped or tagged for 12 VDC operation.

1. With the UCM powered, and in the STOP/RESET mode, disconnect the leads to the solenoid valve(s) from jack J3 of the Power Supply Board A6.
2. With a digital volt-ohmmeter, measure the DC voltage at pin 6 of J3 (or pin 2 on units with four compressors) with respect to chassis ground (pin numbers are labeled on the board, pin 6 thru pin 1 top to bottom). The voltage should read between 20.6 and 16.0 VDC (assuming the line voltage to the transformers is within + or - 10% of nominal. If the voltage does not fall within this range, perform the Transformer 1T12 Checkout Procedure. If the transformer checkout is completed without a failure, install a new power supply board A6.

3. If the voltage reads within the above range, first check the external wiring to the solenoids for continuity. The expected resistance of the circuit with the plugs disconnected at the UCM is from about 7 ohms (cool coil at 50°F) to 12 ohms (previously energized hot coil).
4. Assuming the circuit(s) test good, reconnect the solenoid valve(s) (the coils should NOT pick up) and with a digital volt-ohmmeter, measure the DC voltage between pin 5 of J3 and chassis ground (for solenoid valve circuit #1) and between pin 1 and chassis ground (for solenoid valve circuit #2). If the voltage is more than one volt less than the voltage measured in step two above or the coil(s) pick up or energize as soon as the connector plugged onto the board replace the power supply board. Otherwise continue on to the following step. Note: It may be necessary to partially pull off the connector plugged onto J3 to access the pin(s) with the meter probe if they cannot be proved from above at the lead entrance to the connector. In doing so be careful not to inadvertently disconnect the solenoid circuit as this will cause the board to fail the above test.
5. Reset the UCM and then place it in the AUTO/LOCAL mode, adjust set points, and satisfy interlocks for normal staging of compressors. With a digital volt-ohmmeter measure the voltage applied across the leads to solenoid Valve #1 (J3 pins 6 & 5 on board A6). After the two minute time out period, a voltage should appear across solenoid valve #1 about 1 second prior to the attempted compressor starting. This voltage should read between 12.0 and 15.75 volts DC and it should be present when any of the Compressors (A or B) of the first refrigeration circuit are running (with the exception of the pump down period).

If the chiller is a two circuit machine, Solenoid Valve #2 should also be checked in a similar manner. To do this, reset the UCM and reinitiate normal staging in the AUTO/LOCAL mode. After the two-minute time out period, a voltage should appear for 1 second across Solenoid Valve #2 (J3 pins 1 and 2). The voltage should also read between 12.0 and 15.75 volts DC. This brief energization, just prior to Solenoid Valve #1 is for an internal test. Solenoid Valve #2 will energize again and remain energized as long as either compressor (C or D) of the second refrigeration circuit is running (with the exception of the pump down period).

(Note: During the pump down period, the respective solenoid valve will be de-energized not more than 30 seconds prior to the last compressor being staged off.)

(Note: For dual circuit machines in the auto alternating lead lag mode, circuit #1 compressors will always lead the first time after a power down or a front panel reset.)

TABLE 1: SECTION THREE
 POWER TRANSFORMERS (1T2)
 SECONDARY VOLTAGE RANGES PER PIN PAIRS (AT JACK J1, BOARD A6)

WINDING #	PIN #'S	COLORS	VOLTAGE RANGE (VAC)
NA	11	GREEN	GND
1	10,9	RED	13.1 TO 19.5
2	8,7	BLK,BLU	14.4 TO 21.8
3	6,4	BROWN	4.25 TO 6.5
3 (CT)	5,6 OR 5,4	BRN/YEL,BRN	45% TO 55% OF VOLTAGE MEASURED AT PINS 6,4
NA	3	KEYING PIN	NO CONNECT
4	2,1	YEL	7.85 TO 11.7

Note: The above ranges will apply with the line voltage at +10 to -15% of nominal under any load conditions. For winding #1, the measured voltage will tend towards the high side of the range since the UCM is normally not fully loaded (all outputs on) during the service procedures. If measurements are made without the transformer connected to the UCM, the voltages will all tend toward the high side of their ranges.

TABLE 2: SECTION THREE
POWER TRANSFORMERS (1T12)
SECONDARY VOLTAGE RANGE (AT JACK J2, BOARD A)

WINDING #	PIN #'S	COLORS	VOLTAGE RANGE (VAC)
1	3,1	BLU,BLK	11.0 TO 15.3
NA	2	KEYING PIN	NO CONNECT

Note: The above ranges will apply with the line voltage at +10% of nominal under any load conditions. The measured voltage will tend towards the high side of the range since the transformer is normally not loaded (pump down solenoid valves are de-energized) during the service procedures.

TABLE 3: SECTION THREE
POWER SUPPLY BOARD (A6)
OUTPUT VOLTAGE RANGES (AT JACK J4, TP1 THRU TP16)

TEST POINT (OR PIN #)	DESCRIPTION	VOLTAGE RANGE
1 TO 2	+18 HALF WAVE*	5.9 TO 8.8 VDC
3 TO 4*	+18 HALF WAVE*	5.9 TO 8.8 VDC
5 TO 6	FILAMENT VOLTAGE*	2.4 TO 4.1 <u>VAC</u> NOT VDC
5 TO 4*	FILAMENT VOLT BIAS*	-13.3 TO -24.2 VDC
8 TO 9	REG. +12 VDC	11.4 TO 12.6 VDC
10 TO 9	REG. +5 VDC	4.75 TO 5.25 VDC
11 TO 9	UNREG. 12V FOR SOLENOID VALVES*	11.0 TO 21.1 VDC
12 TO 9	-23 VDC GRID, ANODE (OFF VOLTAGE)*	-19.3 TO -30.2 VDC
13 TO 9	ROTATION OUTPUT (NORMAL)	3.5 TO 4.1 VDC
14 TO 9	HI/LOW LINE OUTPUT (NORMAL RANGE)	4.0 TO 6.0 VDC
15 TO 9	SOL. VALVE #1 INPUT (VALVE OFF)	0 TO .7 VDC

*Negative ground

Note: The above ranges will apply with the line voltage at +10 to -15% of nominal under any load conditions. If measurements are made without the UCM loads connected to the Power Supply Board, the unregulated voltages (*) will all tend toward the high side of their ranges and be dependent on the incoming line voltage.

SECTION 4 RELAY AND OUTPUT OPTIONS BOARD CHECKOUT PROCEDURE

OVERVIEW

In general Relay Board #1 (A7), Relay Board #2 (A8) and the Output Options Board (A9) handle all of the 115 VAC input and output for the UCM. All of these boards as well as the Power Supply Board A6 (see Section 3) were designed to be serviceable at the board level within the UCM. The outputs are contact closures of PC board mounted relays. Control voltage inputs are sensed by PC board mounted isolation transformers. Refer to the unit schematic wiring diagram for the connections from these boards to the chiller control components.

For proper operation of relay boards the UCM must be configured for the number of cooling stages and the condenser type (air or water cooled) of the chiller. This is normally done at the factory with dip switch settings on the Micro-Display Board A3. Refer to operating literature for proper dip switch settings if in doubt.

Relay Board #1 (A7) handles control voltage I/O (inputs/outputs) associated with refrigeration circuit #1 including compressor contactor outputs, crankcase heater outputs, and high pressure switch input. Additionally the board has condenser water pump or condenser fan outputs, flow switch interlock input and external stop input. Note that connections to the relay outputs are provided for both pins for factory installed MTA connectors and by screws of terminal block TB1 for field connections.

RELAY BOARD A7, PLUG J1 COMMALITY TO TB1

J1 PIN	COMMON TO	TB1 TERMINAL
1		--
2		--
3		5 & 7
4		--
5		--
6		--
7		--
8		3
9		2
10		1

Relay Board #2 (A8) handles control voltage I/O associated with refrigeration circuit #2 similar to the A7 board.

The Outputs Options Board (A9) handles outputs only for hot-gas bypass, compressor running indication, and alarm indication. Only the hot-gas bypass relay contacts are factory wired. The remaining outputs are provided as contacts with 120 VAC, 180 VA pilot duty ratings. Terminals 1 and 2 of TB-1 are unused at this time.

PROCEDURE

DIAGNOSIS AT THE UCM LEVEL

The following diagnostics, operating codes or symptoms could indicate a potential problem with the Relay or Output Options Boards.

1. If the following diagnostics or problems are noted, reset the UCM and operate with all power on in the AUTO/LOCAL mode while accomplishing the checks listed. In some cases it may be necessary to satisfy all interlocks and provide a load (set point adjustment) to allow the chiller to stage on in order to identify the problem.

WARNING: To prevent injury or death due to electrical shock, use care when measurements, adjustments, or other service-related operations are performed with power on.

<u>REGISTER</u>	<u>CODE</u>	<u>DESCRIPTION</u>	<u>POSSIBLE CAUSES AND CHECKS</u>
A	100	EXTERNAL UNIT STOP	BOARD A7: CHECK 115 VAC TO TB1-6, CHECK NEUTRAL TO J1-6. IF VOLTAGES AND NEUTRAL ARE PRESENT AND UCM WILL NOT LEAVE A 100 CODE, REPLACE BOARD A7.
B(OR C)	Ed	CHILLED WATER FLOW NEUTRAL	BOARD A7: CHECK 115 VAC TO TB1-4, CHECK NEUTRAL TO J1-6. IF VOLTAGES AND NEUTRAL ARE PRESENT AND UCM WILL NOT LEAVE B Ed CODE, REPLACE BOARD A7.
B(or C)	F5	HIGH PRES. CUTOUT CIRCUIT #1	BOARD A7: CHECK 115 VAC TO E1, CHECK NEUTRAL TO J1-6. IF VOLTAGES AND NEUTRAL ARE PRESENT AND DIAGNOSTIC REOCCURS, REPLACE BOARD A7.
B(or C)	F6	HIGH PRES. CUTOUT CIRCUIT #2	BOARD A8: CHECK 115 VAC TO E1, CHECK NEUTRAL TO J1-6. IF VOLTAGES AND NEUTRAL ARE PRESENT AND DIAGNOSTIC REOCCURS, REPLACE BOARD A8.
B A	E4	PHASE LOSS RUNNING ALTERNATING WITH COOLING LEVEL 21, 22, 23 OR 24 CODE	BOARD A7 OR A8: CHECK RESP. OUTPUT TO COMP. CONTACTOR. IT SHOULD ENERGIZE FOR 2 SEC. MIN. AT TIME OF ATTEMPTED STAGE. COOLING LEVEL CODE INDICATES WHICH STAGE WAS LAST ATTEMPTED. REFER TO OP. LIT. FOR NORMAL STAGING INFORMATION.
NO CODE ASSOC.		CRANKCASE HEATER MISOPERATION	BOARD A7 OR A8: CRANKCASE HEATERS SHOULD BE ENERGIZED WHENEVER RESPECTIVE COMP. IS OFF. CHECK FOR 115 VAC AT J1-3, E2 AND E3.
NO CODE ASSOC.		CONDENSER FAN OR CONDENSER PUMP MISOPERATION	BOARD A7 OR A8: CONDENSER FAN STAGING IS DEPENDENT PRIMARILY ON OUTDOOR AIR TEMP. BUT AT LEAST ONE CONDENSER FAN SHOULD BE ON PER REFRIGERATION CIRCUIT IF A COMPRESSOR IN THAT CIRCUIT IS RUNNING. IF THE CHILLER IS WATER COOLED, CONDENSER PUMP SHOULD BE STARTED WITH ANY COMPRESSOR. CHECK FOR 115 VAC AT J1-8, AND AT PINS J1-9 AND J1-10 AT A TIME WHEN THEY SHOULD BE ENERGIZED. REFER TO OPERATION LITERATURE FOR FAN STAGING INFORMATION.

B (or C)	CA,Cb, CONTACTOR COMP. A,B,C,D CC OR Cd	BOARD A7 OR A8: THIS DIAGNOSTIC APPEARS WHEN THE CURRENT TRANSFORMER CONTINUE TO SENSE CURRENT AFTER THE UCM HAS COMMANDED THE RESPECTIVE COMP. OFF. CHECK FOR NO VOLTAGE AT J1-1 AND J1-2 MORE OFTEN THIS DIAGNOSTIC OCCURS DUE TO A WELDED CONTACTOR A MISWIRED TRANSFORMER, OR A BAD MICRO-MODULE.
NO CODE ASSOC.	HOT GAS BYPASS VALVE MISOPERATION	BOARD A9: CHECK FOR 115 VAC ON TB1-4. WHEN UCM DISPLAYS OPERATING CODE A 20, CHECK FOR 115 VAC ON TB1-5.
NO CODE ASSOC.	COMPRESSOR RUNNING CONTACT MISOPERATION	BOARD A9: WITH NO COMPRESSORS RUNNING, TB1-11 TO TB1-10 SHOULD BE CLOSED AND TB1-11 TO TB1-9 SHOULD BE OPEN. THE REVERSE SHOULD OCCUR WITH ANY COMPRESSOR RUNNING.
NO CODE ASSOC.	ALARM INDICATION CONTACT MISOPERATION	BOARD A9: WITH NO MANUAL RESET DIAGNOSTIC PRESENT, TB1-8 TO TB1-7 SHOULD BE CLOSED AND TB1-8 TO TB1-6 SHOULD BE OPEN. THE REVERSE SHOULD OCCUR WITH ANY ACTIVE MANUAL RESET DIAGNOSTICS PRESENT.

2. If the above checks suggest a problem with the boards (as opposed to external connections, wiring or controls) it may be necessary to further check out the offending boards within the UCM to differentiate between a board problem or a Micro-module problem. Unless the above procedure directly advised board replacement, go on to the diagnosis at the board level.

DIAGNOSIS AT THE BOARD LEVEL

1. Place the UCM in the STOP/RESET mode and disconnect all power to the chiller.
2. CAUTION: Static sensitive components are exposed during this procedure. Service personnel must use a wrist grounding strap. Also the tools used shall be grounded through momentary contact with the module chassis prior to any servicing.
3. Remove screws E & F (See Figure C) that secure the right hand guard to the Micro-module assembly.
4. Remove screws A, B, C, and D (see Figure C) that secure the Micro-module assembly to the subbase. Carefully open the Micro-module which is hinged on the left hand side of the subbase. Be careful not to bind the hinged section or disrupt external wiring. With the Micro-module swung open, the Relay Board(s) A7 (& A8) and the board A9 (if present) are exposed on the right hand side of the subbase. Additionally, the Power Supply Board A6 located on the left hand side is exposed.
5. First check the ribbon cables which connect to the J2 of the Relay Board(s) A7 and A8 and to J1 of the output options board A9 to ensure they are plugged on securely. Additionally check all the ribbon cable connections inside the Micro-module located just below the right hand guard removed in Step 3.
6. Next check for any obvious physical damage to the boards especially on or near the board mounted transformers. Replace the board if any charring or damage is evident to the board or components.
7. Re-apply line voltage power to the UCM power transformers (1T2 and 1T12) but DO NOT APPLY 115 VAC CONTROL VOLTAGE; pull control power fuse 1F7 or leave externally provided 115 VAC source disconnected. The UCM should be left in STOP/RESET mode. The UCM display should indicate "A 00" operating code.

8. On the suspect board A7, A8, or A9 (as present) locate power diodes CR-1 and CR-2. With a digital volt-ohmmeter set on DC Volts, measure the voltage at each with respect to chassis ground. The anode end of the diode is the side opposite the silver band, see Figure 1. All measurements should be between 5.9 and 8.8 volts DC. If the voltage read is out of range, the Power Supply Board or connections to the Power Supply Board via the Micro-module are suspect. Refer to Section 3 for Power Supply checkout procedures. If the readings are in range go on to step 9.
9. On the suspect board A7, A8, and A9 (as present) locate Q1 a small transistor. With the digital volt-ohmmeter set on DC Volts, carefully measure the emitter of the transistor with respect to chassis ground. The emitter lead of the transistor is marked by the letter "E" on the board. The voltage should read between 11.5 and 12.5 volts. If not, replace the board. If in range go to step 10.
10. Next carefully measure the voltage on the collector of the same transistor Q1 with respect to chassis ground. The collector lead of the transistor is marked by the letter "C" on the board. The voltage should read between 11.0 and 12.5 volts. If not, go to step 11. If it is within range, go to step 12.
11. Measure the voltage on the base of the transistor Q1 with respect to chassis ground (the lead marked with a "B" on the board). It should read less than 4 volts. If it does not, the micro-module or the connection to the micro-module is suspect. If it is less than 4 volts, then repeat step 10. If the voltage again is out of range, replace the board.
12. This step will allow the board relays which were suspect in the earlier procedure, to be energized individually by appropriately jumping out their coils to chassis ground. VERIFY THAT 115VAC CONTROL VOLTAGE IS NOT PRESENT AS THIS STEP WOULD OTHERWISE CAUSE COMPRESSORS ETC. TO START AND RUN UNPROTECTED. Refer to Table 1, Section Four, for the output which you like to manually control.

Jumper the component as indicated to energize the specific board relay. Then verify the change of state by looking for continuity between the appropriate output terminals as indicated. Use a digit volt-ohmmeter in ohms or continuity mode. If the relays cannot be made to change state when energized or when de-energized (normal) as indicated, replacement of the board is recommended. If the relays are verified to change state during this step, reapply all power including control voltage, and reverify by repeating checks beginning at step 1, of Section 4. If problems persist and proper operation of external wiring, controls and contactors are verified, change out the entire UCM.

TABLE 1 SECTION FOUR, BOARD RELAY MANUAL OPERATION

BOARD	OUTPUT	JUMPER TO CHASSIS GND	RELAY	OUTPUT TERMINALS
A7	COMPRESSOR A	ANODE OF CR6	K1	E1 TO J1-1
A7	COMPRESSOR B	ANODE OF CR7	K2	E1 TO J1-2
A7	CRKCASE HEATER A	NORMAL	K1	E2 TO J1-3
A7	CRKCASE HEATER B	NORMAL	K2	E3-TO J1-3
A7	COND FAN #1/PUMP	ANODE OF CR8	K3	TB1-3 TO TB1-2 AND J1-8 TO J1-9
A7	COND FAN #2 & 3	ANODE OF CR9	K4	TB1-3 TO TB1-1 AND J1-8 TO J1-10
A8	COMPRESSOR C	ANODE OF CR4	K1	E1 TO J1-1
A8	COMPRESSOR D	ANODE OF CR5	K2	E1 TO J1-2
A8	CRKCASE HEATER C	NORMAL	K1	J1-3 TO E2

A8	CRKCASE HEATER D	NORMAL	K2	J1-3 TO E3
A8	COND FAN #4	ANODE OF CR6	K3	TB1-3 TO TB1-2 AND J1-8 TO J1-9
A8	COND FAN #5 & 6	ANODE OF CR7	K4	TB1-3 TO TB1-1 AND J1-8 TO J1-10
A9	HOT GAS BYPASS	ANODE OF CR3	K1	TB1-4 TO TB1-5
A9	ALARM	ANODE OF CR4	K2	TB1-8 TO TB1-6
A9	ALARM	NORMAL	K2	TB1-8 TO TB1-7
A9	COMPRESSOR RUN	ANODE OF CR5	K3	TB1-11 TO TB1-9
A9	COMPRESSOR RUN	NORMAL	K3	TB1-11 TO TB1-10

FIGURE ONE

CHASSIS GROUND - 4 SIDES

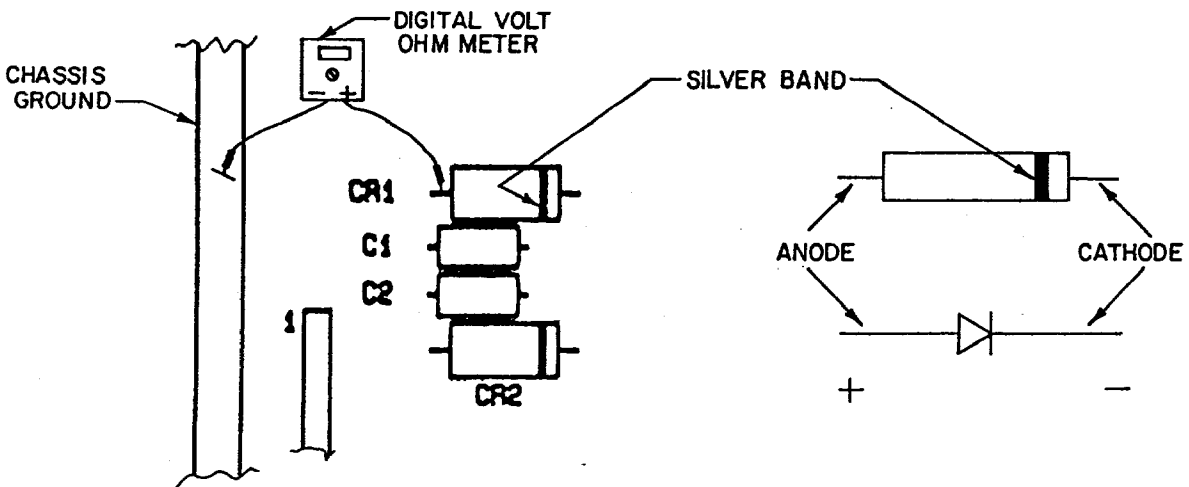
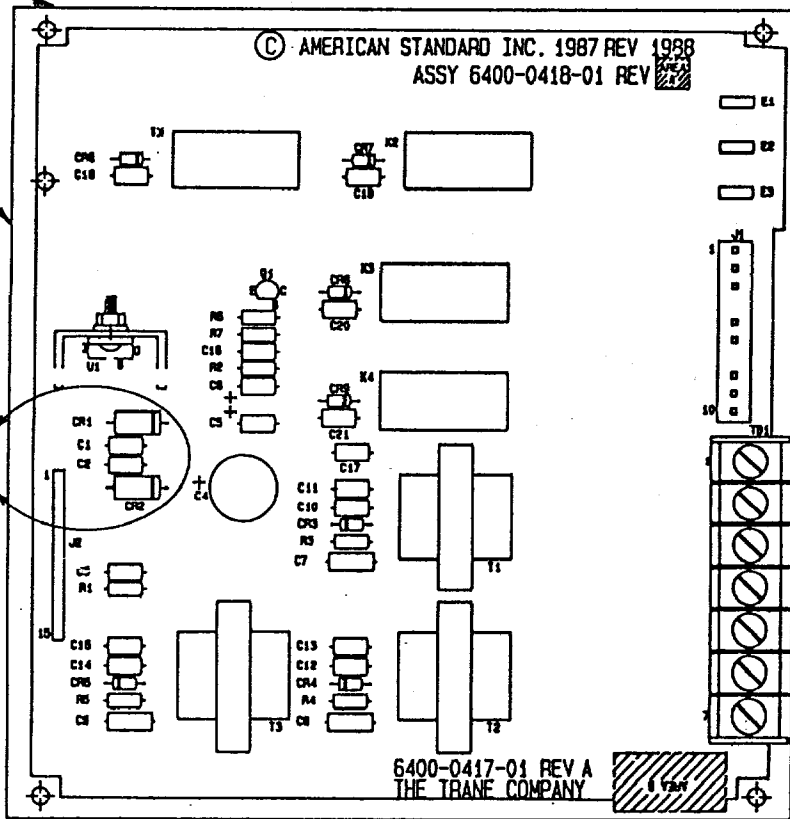

SECTION A - A