



# Comm5 Wiring Installation

---

This wiring information applies to the following Trane products:

- Tracer Summit systems (Comm5 communications, Version 12.0 and higher)
- Tracker systems (BMTK models)
- Tracer loop controller systems
- Tracer MP580/581 systems



## Notice:

Warnings and Cautions appear at appropriate sections throughout this manual. Read these carefully.

### **▲WARNING**

Indicates a potentially hazardous situation, which, if not avoided, could result in death or serious injury.

### **▲CAUTION**

Indicates a potentially hazardous situation, which, if not avoided, may result in minor or moderate injury. It may also be used to alert against unsafe practices.

### **CAUTION**

Indicates a situation that may result in equipment or property-damage-only accidents.

## Conventions used:

The following notifications and formats may appear at appropriate locations throughout this guide.

### **IMPORTANT**

Alerts installer, servicer, or operator to potential actions that could cause the product or system to operate improperly but will not likely result in potential for damage

---

#### **Note:**

A note may be used to make the reader aware of useful information, to clarify a point, or to describe options or alternatives.

- ◆ This symbol precedes a procedure that consists of only a single step.

™ ® The following are trademarks or registered trademarks of their respective companies: Lon-Talk from Echelon Corporation; Rover, Tracer, Tracer Summit, Tracker, Trane, and VariTrac from Trane.



## Wiring and topology recommendations

Comm5 is Trane's implementation of LonTalk®. Trane has updated its recommendations for Comm5 wiring and topology. These recommendations are different than originally published Comm5 installation practices. The following information summarizes the wiring and topology recommendations:

- Use 22 AWG Level 4 unshielded communication wire for most Comm5 installations.
- Use shielded Level 4 wire for all communication wiring on the Vari-Trac central control panel (CCP). See "Specifications for Level 4-compliant cables" on page 11.
- Limit Comm5 links to 4,500 ft and 60 devices maximum (without a repeater).
- Use the following termination resistors on all links:
  - 105  $\Omega$  at each end for Level 4 wire
  - 82  $\Omega$  at each end for Trane "purple" wire
- Use daisy chain topology.
- Limit zone sensor communication stubs to 8 per link, 50 ft each maximum.
- Use one repeater for an additional 4,500 ft, 60 devices, and 8 communication stubs.

## Recommended wiring practices

To ensure proper network communication, follow these recommended wiring and planning guidelines when installing communication wire:

- All wiring must comply with the National Electrical Code (NEC) and local codes.
- Although Comm5 does not require polarity sensitivity, Trane recommends keeping polarity consistent throughout the site.
- Make sure that 24 Vac power supplies are consistent in how they are grounded. Avoid sharing 24 Vac between Comm5 controllers.
- Avoid overtightening cable ties and other forms of cable wraps. This can damage the wires inside the cable.
- Do not run Comm5 cable alongside or in the same conduit as 24 Vac power. This includes the conductors running from triac-type inputs.
- In open plenums, avoid running wire near lighting ballasts, especially those using 277 Vac.
- Use a daisy chain configuration.
- Use termination resistors as described in "Termination resistance placement for Comm5 links" on page 5.
- Insulate termination-resistor leads.
- Use only one type of communication wire; do not mix different types of wire.

## Wiring requirements

The recommended Comm5 communication-link wiring is 22 AWG, Level 4, twisted-pair wire. See “Specifications for Level 4-compliant cables” on page 11. The wire can be either shielded or unshielded. However, unshielded wire is recommended for most installations. You can also use low capacitance, 18 AWG, shielded, twisted-pair with stranded, tinned-copper conductors (Trane “purple” wire).

The maximum wire length for Comm5 communication links is 4,500 ft (1,400 m). Comm5 communication-link wiring must be installed in a daisy-chain configuration (Figure 1 and Figure 2 on page 4).

**Figure 1. Daisy chain configuration**

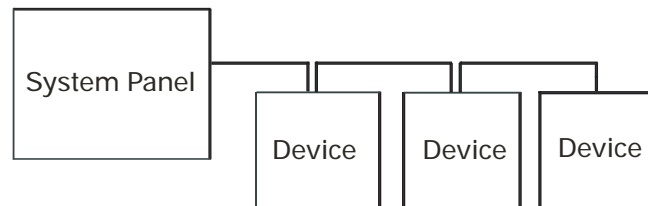

**Figure Note:**

- Maximum wire length for Comm5 is 4,500 ft (1,400 m)  
(Comm5 wire length limitations can be extended through the use of a link repeater; see “Comm5 physical link repeater” on page 6.)
- For termination resistor placement, see “Termination resistance placement for Comm5 links” on page 5.

**Figure 2. Alternate daisy chain configuration**

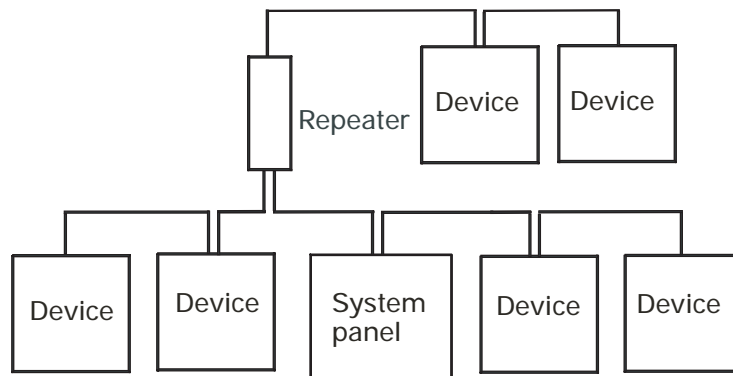

**Figure Note:**

- The system panel may be placed in the middle of the link.
- Maximum wire length for Comm5 is 4,500 ft (1,400 m) on each side of the repeater
- For termination resistor placement, see “Termination resistance placement for Comm5 links” on page 5.

## Termination resistance placement for Comm5 links

Termination resistors are required at each end of Comm5 communication daisy chain links. To correctly place termination resistors, follow these guidelines:

- Terminate a daisy chain configuration with a resistor at each end of the link (Figure 3):
  - 22 AWG, Level 4 wire, 105  $\Omega$ , 1%, ¼ W
  - 18 AWG, Trane “purple” wire, 82  $\Omega$ , 1%, ¼ W
- If a repeater is used, each link of the configuration that is created by the repeater requires termination resistors (Figure 4 on page 6).
- Trane recommends that only one type of wire be used for the Comm5 communication link.
- Make a set of as-built drawings or a map of the communication wire layout during installation. Any sketch of the communication layout should feature the termination resistor placement.

**Figure 3. Daisy chain resistor placement**

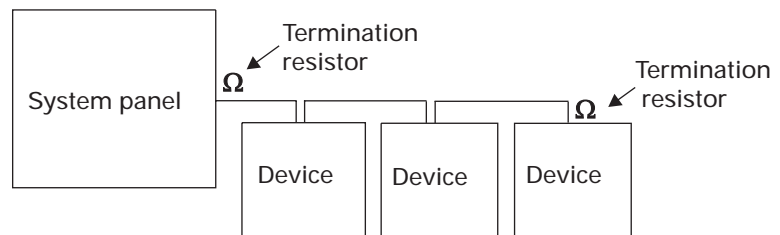

**Figure Note:**

- Use 105  $\Omega$ , 1%, ¼ W for 22 AWG, Level 4.
- Use 82  $\Omega$ , 1%, ¼ W for 18 AWG, Trane “purple” wire.

**Figure 4. Alternate daisy chain resistor placement**

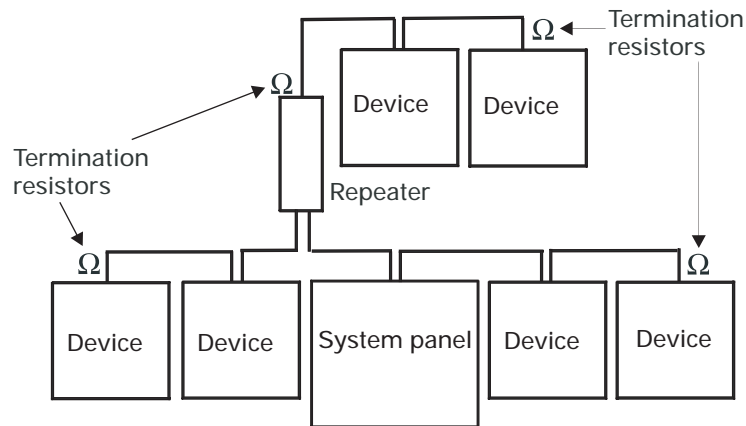

**Figure Note:**

- Maximum wire length for the entire configuration is 4,500 ft (1,400 m).
- Comm5 wire length limitations can be extended through the use of a link repeater, see “Comm5 physical link repeater.”

## Comm5 physical link repeater

A Comm5 link repeater regenerates the signal on a Comm5 link. The configurations on either side of the repeater should be daisy chain. Both link segments require proper termination (Figure 4).

### Link repeater requirements

A link repeater is required when:

- The total wire length is greater than the maximum wire run length of 4,500 ft (1,400 m).
- More than 60 devices are connected to a link—This total does not include the BCU, the link repeater, and the temporary use of a service tool on the same link.
- More than eight zone sensor communication stubs (maximum 50 ft) are required on a Comm5 link—See “Comm5 zone sensor comm jack” on page 9.

### Link repeater guidelines

Follow these guidelines when using link repeaters:

- Use only one link repeater on a link.

**Note:**

Use a repeater to double the maximum allowable wire length. For example, when a repeater is used with a daisy chain configuration, the total wire length can be 9,000 ft (3,800 m) (with half the wire length on either side of the repeater).

- Limit the link repeater to 60 devices on either side of the link.
- Use an earth ground with the link repeater. Make sure the installer is aware of this before making any power connections.

## Link repeater connections

The recommended shield connections are shown in Figure 5. Use these connections for instances where shielded communication wire is used. For an example of using a repeater to create an extended daisy chain configuration, see Figure 6 on page 8.

Follow these guidelines when using a repeater:

- Read the *Comm5 repeater installation* (3270 3285) information that comes with the link repeater.
- For information about terminating daisy chain configurations, see “Termination resistance placement for Comm5 links” on page 5.
- Connect shield-drain wires entering the repeater to a terminal marked with a capacitor symbol. The entering shield-drain wire must be connected to earth ground at the system panel.
- Connect shield-drain wires leaving the repeater to the repeater terminal marked with an earth ground symbol.

Figure 5. Comm5 shield repeater connection

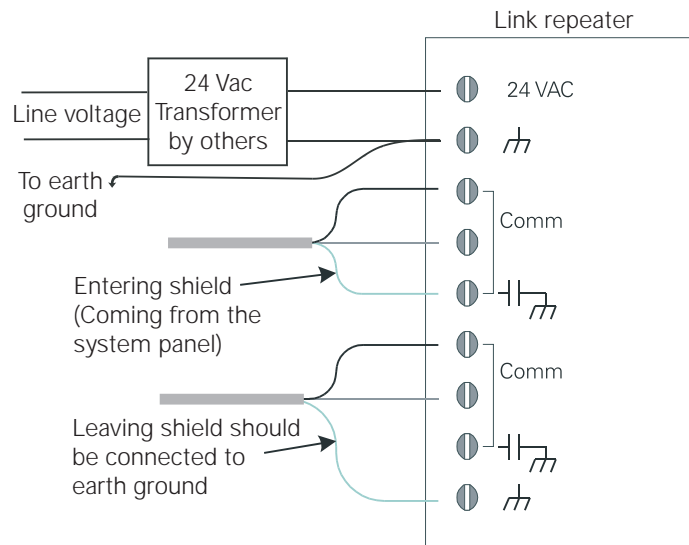

**Figure 6. Comm5 daisy chain repeater connection and shielded wire**

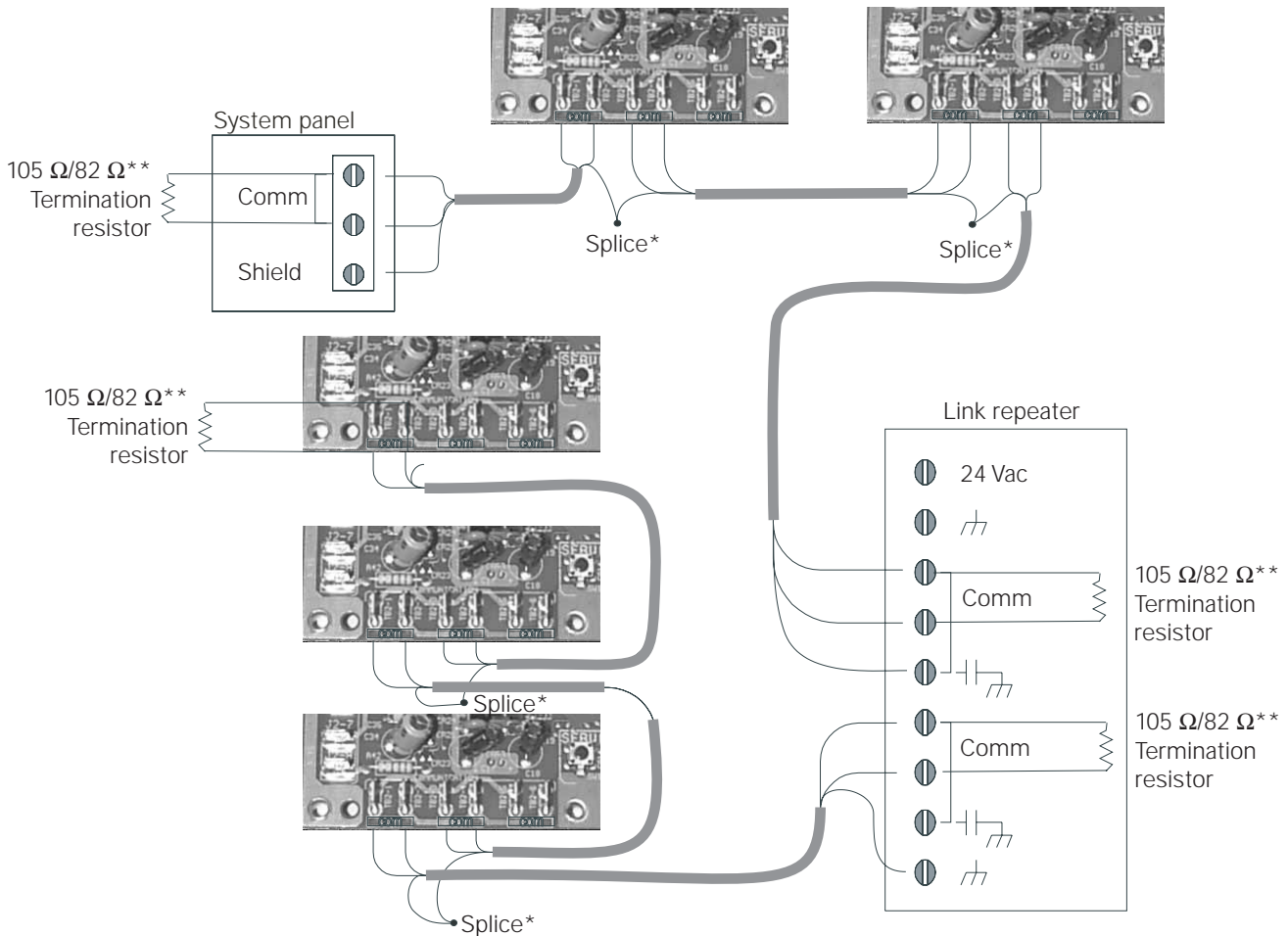

**Figure Note:**

\* A continuous shield is required when shielded wire is used. At each controller, splice shield wire and tape back to prevent grounding. Connect shield wire to earth ground at system panel and repeater. If unshielded communication wire is used, no shield connections are necessary.

\*\* The value of the termination resistor is dependent on the wire type: 105 Ω for 22 AWG, Level 4 wire and 82 Ω for 18 AWG, Trane "purple" wire.

## Comm5 zone sensor comm jack

Many Trane zone sensor models include a communication jack. When properly wired to the communication terminals on the unit controller, the communication jack provides easy access to both the controller and the entire Comm5 link. This access enables you to view and modify the status and configuration information of any controller on the link using the Rover service tool.

The recommended wire between the controller and the communication jack is 22 AWG, Level 4 wire; or 18 AWG shielded, twisted-pair with stranded, tinned-copper conductors (Trane “purple” wire). Thermostat wire is not recommended for the communication jack.

## Zone sensor communication stubs

The wire that runs between the controller and zone sensor is commonly referred to as the communication stub. Figure 7 shows an example of communication stubs on a Comm5 link when a repeater is used.

**Note:**

- Only eight stubs can be used per Comm5 link. To add more stubs to the link, use a repeater. Up to eight stubs may be used on each side of the repeater (16 total stubs).
- Each communication stub must not exceed 50 ft in length.

**Figure 7. Communication stubs used with a repeater**

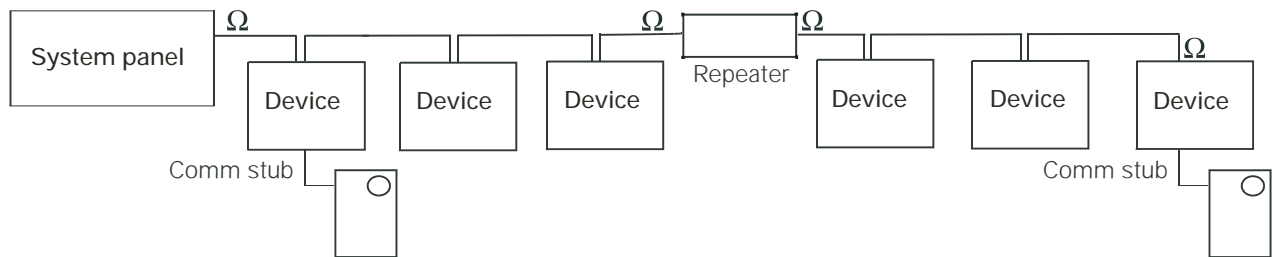

**Figure Note:**

- Maximum wire length on either side of the repeater is 4,500 ft (1,400 m).
- The link repeater is limited to 60 devices on either side of the link.
- Place termination resistors at the end of each link. Use a 105 Ω resistor at each end of the link for Level 4 wire and an 82 Ω resistor for Trane “purple” wire.

## Verifying communication status

The information in this section will help you to interpret the Comm light-emitting diode (LED) on the Comm5 system panel. The yellow Comm LED indicates the communication status of the Comm5 controller. Table 1 describes Comm LED activity.

**Table 1. Yellow Comm LED**

LED activity	Explanation
LED is off continuously	The controller is not detecting any communication (normal for stand-alone applications).
LED blinks	The controller detects communication (normal for communicating applications).
LED is on continuously	This is a condition that may occur during discovery. The LED may flash fast enough to look as if it is on continuously. If this LED activity occurs at any other time, the site may have excessive radio frequency interference (RFI).



## Specifications for Level 4-compliant cables

**Table 2. Cable specifications**

Specification	Value	
dc resistance (Maximum resistance of a single copper conductor regardless of whether or not it is solid or stranded and regardless of whether or not it is metal coated.)	18.0 $\Omega$ /1,000 ft 20°C	
dc resistance unbalance (maximum)	5%	
Mutual capacitance of a pair (maximum)	17 pF/foot	
Pair-to-ground unbalance (maximum)	1,000 pF/foot/1,000 ft	
Characteristic impedance	772 kHz	102 $\Omega$ $\pm$ 15%
	1.0 MHz	100 $\Omega$ $\pm$ 15%
	4.0 MHz	100 $\Omega$ $\pm$ 15%
	8.0 MHz	100 $\Omega$ $\pm$ 15%
	10.0 MHz	100 $\Omega$ $\pm$ 15%
	16.0 MHz	100 $\Omega$ $\pm$ 15%
	20.0 MHz	100 $\Omega$ $\pm$ 15%
Attenuation (maximum dB/1,000 ft at 20°C)	772 kHz	4.5 dB/1,000 ft at 20°C
	1.0 MHz	5.5 dB/1,000 ft at 20°C
	4.0 MHz	11.0 dB/1,000 ft at 20°C
	8.0 MHz	15.0 dB/1,000 ft at 20°C
	10.0 MHz	17.0 dB/1,000 ft at 20°C
Worst-pair near-end crosstalk (minimum) (Values shown are for information only. The minimum NEXT coupling loss for any pair combination at room temperature is to be greater than the value determined using the formula $NEXT(F_{MHz}) > NEXT(0.772) - 15 \log_{10}(F_{MHz}/0.72)$ for all frequencies in the range of 0.772 MHz–20 MHz for a length of 1,000 ft.)	772 kHz	58 dB
	1.0 MHz	56 dB
	4.0 MHz	47 dB
	8.0 MHz	42 dB
	10.0 MHz	41 dB
	16.0 MHz	38 dB
	20.0 MHz	36 dB
dc resistance unbalance (maximum)	5%	



Trane  
A business of American Standard Companies  
[www.trane.com](http://www.trane.com)

For more information, contact your local Trane  
office or e-mail us at [comfort@trane.com](mailto:comfort@trane.com)

Literature Order Number	BAS-SVN01A-EN
File Number	SV-ES-BAS-BAS-SVN-01A-EN-0603
Supersedes	New
Stocking Location	Electronic only

Trane has a policy of continuous product and product data improvement and reserves the right to change design and specifications without notice. Only qualified technicians should perform the installation and servicing of equipment referred to in this publication.