

TABLE OF CONTENTS		
TITLE	SHEET	LINE NUMBERS
TABLE OF CONTENTS, NOTES, & FUSE REPLACEMENT TABLE	1	N/A
LEGEND	2	N/A
POWER; COMPRESSORS, & TRANSFORMERS	3	1-75
POWER; CONDENSER FANS	4	76-150
CONTROLS; CONDENSER FANS	5	151-225
CONTROLS; COMPRESSOR VFDS	6	226-300
CONTROLS; COMPRESSOR VFDS - REMOTE MOUNTED	7	301-375
CONTROLS; REFRIGERATION	8	376-450
CONTROLS	9	451-525
CUSTOMER CONNECTIONS	10	526-600
GLOBAL BUS	11	601-675

CONTROL TRANSFORMER SECONDARY CLASS CC		
DESIGNATION	VOLTAGE	RATING
1F13	380V	10A
	460V	10A
1F14	400V	10A
	400V	10A
CONTROL TRANSFORMER PRIMARY CLASS CC		
1F15	380V	5A
	460V	5A
1F16	400V	5A

CONDENSER FANS CLASS CC		
DESIGNATION	TONNAGE	RATING
1F1	115, 130	20A
1F2	150, 170, 180	30A
1F3	200, 215, 230, 250, 270	30A
1F4	115, 130	30A
1F5	150, 170, 180	30A
1F6	200, 215, 230, 250, 270	30A
1F7	115, 130	30A
1F8	150, 170, 180	30A
1F9	200, 215, 230, 250, 270	30A
1F10	115, 130	20A
1F11	150, 170, 180	30A
1F12	200, 215, 230, 250, 270	30A

GENERAL NOTES:

- UNLESS OTHERWISE NOTED, ALL SWITCHES ARE SHOWN AT 25C (77F), AT ATMOSPHERIC PRESSURE, AT 50% RELATIVE HUMIDITY, WITH ALL POWER REMOVED, AND AFTER A NORMAL SHUTDOWN HAS OCCURRED.
- WIRES REPRESENTED BY DASHED LINES INDICATE RECOMMENDED FIELD WIRING BY OTHERS. WIRES REPRESENTED BY SOLID LINES INDICATE FACTORY INSTALLED WIRING.
- DASHED LINE ENCLOSURES AND/OR DASHED DEVICE OUTLINES INDICATE OPTIONAL COMPONENTS WIRING.
- NUMBERS ALONG THE RIGHT SIDE OF THE SCHEMATIC DESIGNATE THE LOCATION OF COMPONENT CONTACTS BY LINE NUMBER. AN UNDERLINED NUMBER INDICATES A NORMALLY CLOSED CONTACT.
- ALL FIELD WIRING MUST BE IN ACCORDANCE WITH THE NATIONAL ELECTRIC CODE (NEC), STATE, AND LOCAL CODES.
- CLASS 1 FIELD WIRING INSULATION RATING IS REQUIRED TO BE EQUAL TO OR GREATER THAN THE EQUIPMENT SUPPLY VOLTAGE RATING. CLASS 2 FIELD WIRING INSULATION IS REQUIRED TO BE RATED AT 300 V MINIMUM.

FLAG NOTES:

- COMPONENT (LLIDS) ARE NOT NECESSARILY WIRED ON THE IPC BUS IN THE ORDER SHOWN ON SCHEMATIC.
- EXTERNAL STOP AND EMERGENCY STOP CONTACTS ARE JUMPERED IN THE FACTORY BY JUMPERS W1 & W2 TO ENABLE UNIT OPERATION. IF REMOTE CONTROL IS DESIRED, REMOVE THE JUMPERS AND CONNECT TO THE DESIRED CONFIGURATION.
- CONTACT CLOSURE ENABLES ICE MAKING.
- FIELD ASSIGNED PROGRAMMABLE RELAYS.
- ALL UNIT POWER WIRING MUST BE COPPER CONDUCTORS ONLY AND HAVE A MINIMUM INSULATION TEMPERATURE RATING OF 90C.
- CONNECTIONS ARE INTENDED FOR CLASS 2 ONLY.
- ONLY ONE OF THE SHOWN VOLTAGES CAN BE UTILIZED. REFER TO THE UNIT NAMEPLATE FOR THE CORRECT SUPPLY VOLTAGE.
- POWER FOR THE EVAPORATOR HEATER AND/OR OPTIONAL CONVENIENCE OUTLET IS SUPPLIED BY A CUSTOMER PROVIDED POWER SUPPLY. MAX FUSE SIZE IS 20 AMPS FOR EVAPORATORS AND 15 AMPS FOR OPTIONAL CONVENIENCE OUTLET.
- WIRING FOR 1K24 AS SHOWN IN INSET WHEN CHILLED WATER SETPOINT IS ENABLED VIA MODULE 1K25.
- TERMINALS 5 & 6 ARE TO BE WIRED TO CUSTOMER DEMAND LIMIT SETPOINT. INPUT CONFIGURED 2-10 VDC FROM FACTORY. SEE OPERATING INSTRUCTIONS TO CONFIGURE FOR 4-20 mA.
- TERMINALS 2 & 3 ARE TO BE WIRED TO CUSTOMER CHILLED WATER SETPOINT. INPUT CONFIGURED 2-10 VDC FROM FACTORY. SEE OPERATING INSTRUCTIONS TO CONFIGURE FOR 4-20 mA.
- TERMINALS 1 & 3 ARE TO BE WIRED TO REPORT % CAPACITY. OUTPUT CONFIGURED 2-10 VDC.
- WIRES 4B, 5B, 6B, 7B, 8B, 9B ONLY PRESENT WHEN PARALLEL WIRE SETS ARE USED.
- RELAY RATINGS AT 120VAC: 7.2 AMPS RESISTIVE, 2.88 AMPS PILOT DUTY, 1/3 HP, 7.2 FLA. RELAY RATINGS AT 240VAC: 5 AMPS GENERAL PURPOSE.
- SEE AFD PARAMETER LABEL X39003970 FOR ADDITIONAL CONFIGURATION INFORMATION.
- CUSTOMER SUPPLIED POWER: 115/60/1PH OR 230/50/1PH TO POWER RELAYS. MAX FUSE SIZE IS 20 AMPS. GROUND ALL CUSTOMER SUPPLIED POWER SUPPLIES AS REQUIRED BY APPLICABLE CODES. GREEN GROUND SCREWS ARE PROVIDED IN UNIT CONTROL PANEL.
- SHIELDING TO BE GROUNDED AT THE JUNCTION BOX ONLY.
- OPTIONAL TOTAL FREE COOLING.

⚠ WARNING
HAZARDOUS VOLTAGE!
DISCONNECT ALL ELECTRIC POWER INCLUDING REMOTE DISCONNECTS AND FOLLOW LOCK OUT AND TAG PROCEDURES BEFORE SERVICING. INSURE THAT ALL MOTOR CAPACITORS HAVE DISCHARGED STORED VOLTAGE. UNITS WITH VARIABLE SPEED DRIVE, REFER TO DRIVE INSTRUCTIONS FOR CAPACITOR DISCHARGE. FAILURE TO DO THE ABOVE COULD RESULT IN DEATH OR SERIOUS INJURY.

⚠ AVERTISSEMENT
TENSION DANGEREUSE!
COUPER TOUTES LES TENSIONS ET OUVRIR LES SECTIONNEURS A DISTANCE. PUIS SUIVRE LES PROCEDURES DE VERROUILLAGE ET DES ETIQUETTES AVANT TOUTE INTERVENTION. VERIFIER QUE TOUTS LES CONDENSATEURS DES MOTEURS SONT DECHARGES. DANS LE CAS D'UNITES COMPORTANT DES ENTRAINEMENTS A VITESSE VARIABLE, SE REPORTER AUX INSTRUCTIONS DE L'ENTRAINEMENT POUR DECHARGER LES CONDENSATEURS. UN MANQUEMENT A LA PROCEDURE CI-DESSUS PEUT ENTRAÎNER DES BLESSURES GRAVES, VOIRE LA MORT.

⚠ ADVERTENCIA
¡VOLTAJE PELIGROSO!
DESCONECTE TODA LA ENERGIA ELECTRICA, INCLUIDO LAS DESCONEXIONES REMOTAS Y SIGA LOS PROCEDIMIENTOS DE CIERRE Y ETIQUETADO ANTES DE PROCEDER AL SERVICIO. ASEGURESE DE QUE TODOS LOS CAPACITORES DEL MOTOR HAYAN DESCARGADO EL VOLTAJE ALMACENADO. PARA LAS UNIDADES CON TRANSMISION DE VELOCIDAD VARIABLE, CONSULTE LAS INSTRUCCIONES PARA LA DESCARGA DEL CONDENSADOR. NO REALIZAR LO ANTE DICHO PUEDE PROVOCAR LA MUERTE O LESIONES GRAVES.

NOTICE	AVIS	AVISO
USE COPPER CONDUCTORS ONLY! UNIT TERMINALS ARE NOT DESIGNED TO ACCEPT OTHER TYPES OF CONDUCTORS. FAILURE TO DO THE ABOVE COULD RESULT IN EQUIPMENT DAMAGE.	UTILISER QUE DES CONDUCTEURS EN CUIVRE! LES BORNES DE L'UNITE NE SONT PAS CONÇUES POUR RECEVOIR D'AUTRES TYPES DE CONDUCTEURS. UN MANQUEMENT A LA PROCEDURE CI-DESSUS PEUT ENTRAÎNER DES DOMMAGES A L'EQUIPEMENT.	¡UTILICE ÚNICAMENTE CONDUCTORES DE COBRE! LAS TERMINALES DE LA UNIDAD NO ESTÁN DISEÑADAS PARA ACEPTAR OTROS TIPOS DE CONDUCTORES. NO REALIZAR LO ANTE DICHO PUEDE PROVOCAR DAÑOS EN EL EQUIPO.

DRAWN BY: N. SCHAMS	 THIS DRAWING IS PROPRIETARY AND SHALL NOT BE COPIED OR ITS CONTENTS DISCLOSED TO OUTSIDE PARTIES WITHOUT THE WRITTEN CONSENT OF TRANE.
© TRANE DATE: 19-NOV-2014	
MASTER FILE:	
REVISION DATE: 03-MAY-2017	
REPLACES:	
SIMILAR TO:	
USED BY:	
CAD: CREO SCHEMATICS	

TABLE OF CONTENTS	
RTAF	
STANDARD EFFICIENCY 270T HIGH EFFICIENCY 115T-250T	
57226999	SHEET 1
REV 1	M

DEVICE	DESCRIPTION	ZONE
1A1	Adaptiview Touchscreen Display	11-666
1B1	Temperature Switch; Ventilation Fan Enable	6-285
1B2	Temperature Switch; Ventilation Fan Enable	7-346
1B10	Thermal Overload Relay; Pump Motor 1	3-24
1B11	Thermal Overload Relay; Pump Motor 2	3-28
1F1	Fuse; Class CC - Condenser Fan Motor	4-77
1F2	Fuse; Class CC - Condenser Fan Motor	4-78
1F3	Fuse; Class CC - Condenser Fan Motor	4-79
1F4	Fuse; Class CC - Condenser Fan Motor	4-92
1F5	Fuse; Class CC - Condenser Fan Motor	4-93
1F6	Fuse; Class CC - Condenser Fan Motor	4-94
1F7	Fuse; Class CC - Condenser Fan Motor	4-112
1F8	Fuse; Class CC - Condenser Fan Motor	4-113
1F9	Fuse; Class CC - Condenser Fan Motor	4-114
1F10	Fuse; Class CC - Condenser Fan Motor	4-132
1F11	Fuse; Class CC - Condenser Fan Motor	4-133
1F12	Fuse; Class CC - Condenser Fan Motor	4-134
1F13	Fuse; Class CC - Control Power Transformer Secondary	3-52
1F15	Fuse; Class CC - Control Power Transformer Primary	3-45
1F16	Fuse; Class CC - Control Power Transformer Primary	3-45
1K1	Module; Tracer UC800 Unit Controller	11-668
1K2	Module; Interface COMM 5, (Optional) LCI-C	10-586
1K3	Relay; AFD Status - Compressor 1A	6-261
1K4	Relay; AFD Status - Compressor 2A	6-235
1K5	Module; Dual Low Voltage Binary Input - AFD Fault Input	6-238
1K6	Module; Dual Relay Output - AFD Run Command	6-254
1K7	Module; Dual Analog I/O; AFD Speed Command	6-271
1K12	Module; Dual Triac Output - Compressor 1A Load/Unload	8-400
1K13	Module; Dual Triac Output - Compressor 2A Load/Unload	8-410
1K14	Module; Quad Relay Output - Oil Valve Controls	8-428
1K15	Module; Dual Low Voltage Binary Input - Oil Loss Level Sensor	9-502
1K16	Module; Dual Relay Output - Chilled Water Pump Controls	9-467
1K17	Module; Dual High Voltage Binary Input - Dual Pump Fault Input	9-474
1K18	Module; Dual Low Voltage Binary Input - Evaporator Flow Switch	9-487
1K22	Module; Dual Low Voltage Binary Input - (Optional) Ice Making Control	10-536
1K23	Module; Quad Relay Output - (Optional) Unit Status Programmable Relay	10-554
1K24	Module; Dual Analog I/O - (Optional) Percent Capacity & Chilled Water Setpoint	10-566
1K25	Module; Dual Low Voltage Binary Input - (Optional) Auxillary Setpoint Enable	10-577
1K26	Module; Dual Low Voltage Binary Input - Lockout External Stop & Emergency Stop	10-597
1K30	Module; Dual Analog I/O; Condenser Fan Speed	5-170
1K31	Module; Quad Relay Output; Condenser Fan Enable	5-189
1K32	Module; Dual Analog I/O; Condenser Fan Speed	5-209
1K33	Module; Dual Relay Output; Condenser Fan Enable	5-222
1K40	Module; Dual Relay Output; Condenser Liquid Receiver Solenoid	8-441
1K41	Module; Dual Analog I/O; Total Free Cooling, Modulating Valves Actuator	9-467
1M1	Motor; Ventilation Fan 1	6-286
1M2	Motor; Ventilation Fan 2	6-293
1Q1	Circuit Breaker; Power Distribution Circuit 1A	3-7
1Q2	Circuit Breaker; Power Distribution Circuit 1B	3-7
1Q6	Circuit Breaker; Pump Package	3-26
1Q10	Contact; Pump Motor 1	9-464
1Q11	Contact; Pump Motor 2	9-461
1T1	AFD; Compressor 1A	3-38
1T2	AFD; Compressor 2A	3-47
1T5	Transformer; CLASS 1; 1000VA, 380V/400V/460V PRI, 115V SEC	3-48
1T6	Transformer; CLASS 1; 180VA, 115V PRI, 27V SEC	3-60
1T7	Module; Power Supply	3-65
1T8	Module; Power Supply	3-65
1T9	Choke; Circuit 1	3-32
1T10	Choke; Circuit 2	3-41
1T11	Transformer; CLASS 2; 75VA, 120V PRI, 24V SEC	3-59
1X1-1	Terminal Block; Control Power Transformer	3-53
1X2	Terminal Block; Power Distribution Circuit 1A	3-6
1X3-1	Terminal Block; 115V+ Distribution	8-381
1X4-1	Terminal Block; Neutral Distribution	8-381
1X5-1	Terminal Block; Condenser Fan Controls	5-163
1X6-1	Terminal Block; Customer Connection	3-7
1X7-1	Terminal Block; Unit side Wiring	8-389
1X8-1	Terminal Block; Unit side Wiring - Neutral/Ground	8-388
1X10-1	Terminal Block; AFD Controls - Compressor 1A	7-331
1X11-1	Terminal Block; AFD Controls - Compressor 2A	7-307
1X12-1	Terminal Block; Total Free Cooling Controls	3-64
1XJ1	Jack; Condenser Fan Power Circuit 1 - Bank 1	4-77
1XJ2	Jack; Condenser Fan Power Circuit 1 - Bank 2/3	4-92
1XJ3	Jack; Condenser Fan Power Circuit 2 - Bank 1	4-112
1XJ4	Jack; Condenser Fan Power Circuit 2 - Bank 2/3	4-132
1XJ5	Jack; Ventilation Fan 1	6-285
1XJ6	Jack; Ventilation Fan 2	6-292
1XJ7	Jack; AFD Controls - Compressor 1A	6-271
1XJ8	Jack; AFD Controls - Compressor 2A	6-245
1XJ9	Jack; Customer Convenience Outlet	3-18
1XJ35	Jack; Condenser Fan Controls Circuit 1 - Bank 1	5-156
1XJ36	Jack; Condenser Fan Controls Circuit 1 - Bank 2	5-156
1XJ38	Jack; Condenser Fan Controls Circuit 1 - Bank 3	5-199
1XJ44	Jack; Condenser Fan Controls Circuit 2 - Bank 1	5-156
1XJ45	Jack; Condenser Fan Controls Circuit 2 - Bank 2	5-156
1XJ47	Jack; Condenser Fan Controls Circuit 2 - Bank 3	5-199
1XP1	Plug; Condenser Fan Power Circuit 1 - Bank 1	4-77
1XP2	Plug; Condenser Fan Power Circuit 1 - Bank 2/3	4-92
1XP3	Plug; Condenser Fan Power Circuit 2 - Bank 1	4-112
1XP4	Plug; Condenser Fan Power Circuit 2 - Bank 2/3	4-132
1XP5	Plug; Ventilation Fan 1	6-285
1XP6	Plug; Ventilation Fan 2	6-292
1XP7	Plug; AFD Controls - Compressor 1A	6-271
1XP8	Plug; AFD Controls - Compressor 2A	6-245
1XP35	Plug; Condenser Fan Controls Circuit 1 - Bank 1	5-155
1XP36	Plug; Condenser Fan Controls Circuit 1 - Bank 2	5-155
1XP38	Plug; Condenser Fan Controls Circuit 1 - Bank 3	5-198
1XP44	Plug; Condenser Fan Controls Circuit 2 - Bank 1	5-155
1XP45	Plug; Condenser Fan Controls Circuit 2 - Bank 2	5-155
1XP47	Plug; Condenser Fan Controls Circuit 2 - Bank 3	5-198

DEVICE	DESCRIPTION	ZONE
3B1	Switch; High Pressure Cutout - Circuit 1	6-268
3B3	Temperature Switch; Ventilation Fan Enable	7-343
3B3	Temperature Switch; Ventilation Fan Enable	7-319
3BL1	Level Sensor; Oil Loss - Compressor 1A	9-507
3BP1	Pressure Transducer; Suction Pressure - Circuit 1A	11-635
3BP2	Pressure Transducer; Discharge Pressure Circuit 1A	11-639
3BP3	Pressure Transducer; Oil Pressure Circuit 1A	11-643
3BP4	Pressure Transducer; Liquid Pressure Microchannel Evap - Circuit 1A	11-647
3BP5	Pressure Transducer; Evaporator - Circuit 1A	11-655
3BT1	Temperature Sensor; Oil Temperature - Circuit 1A	11-619
3BT2	Temperature Sensor; Discharge Temperature - Circuit 1A	11-623
3BT3	Temperature Sensor; Liquid Line Temperature Microchannel Evap - Circuit 1A	11-627
3BT4	Temperature Sensor; Evaporator Pool Temperature - Circuit 1A	11-651
3E30	Heater; Oil Separator - Circuit 1	8-389
3E31	Heater; Crankcase - Compressor 1A	8-391
3K1	Electronic Expansion Valve	11-631
3M1	Motor; Compressor 1A	3-38
3M3	Solenoid; Proportional Unload Control - Compressor 1A	8-400
3M4	Solenoid; Proportional Load Control - Compressor 1A	8-398
3M7	Solenoid; Oil - Compressor 1A	8-428
3M8	Solenoid; Step Load Control - Compressor 1A	8-425
3M11	Motor; Condenser Fan - Circuit 1	4-77
3M12	Motor; Condenser Fan - Circuit 1	4-92
3M13	Motor; Condenser Fan - Circuit 1	4-82
3M14	Motor; Condenser Fan - Circuit 1	4-97
3M15	Motor; Condenser Fan - Circuit 1	4-87
3M16	Motor; Condenser Fan - Circuit 1	4-102
3M25	Solenoid; Ckt 1 Receiver Tank	8-441
3M32	Motor; Condenser Fan - Circuit 1	4-107
3M41	Motor; Ventilation Fan 1	7-344
3T1	AFD; Compressor 1A	7-335
3T9	Choke; Circuit 2	7-329
3X1-1	Terminal Block; Junction Box - Compressor 1A	8-428
3X2-1	Terminal Block; Junction Box - Oil Separator Circuit 1	9-504
3XJ5	Jack; Ventilation Fan 1	7-343
3XJ7	Jack; AFD Controls - Compressor 1A	7-341
3XP5	Plug; Ventilation Fan 1	7-343
3XP7	Plug; AFD Controls - Compressor 1A	7-341

delete
3BP5

DEVICE	DESCRIPTION	ZONE
4B1	Switch; High Pressure Cutout - Circuit 2	6-242
4B3	Temperature Switch; Ventilation Fan Enable	7-322
4BL1	Level Sensor; Oil Loss - Compressor 2A	9-499
4BP1	Pressure Transducer; Suction Pressure - Circuit 2A	11-623
4BP2	Pressure Transducer; Discharge Pressure Circuit 2A	11-627
4BP3	Pressure Transducer; Oil Pressure Circuit 2A	11-631
4BP4	Pressure Transducer; Liquid Pressure Microchannel Evap - Circuit 2A	11-635
4BP5	Pressure Transducer; Evaporator - Circuit 2A	11-648
4BT1	Temperature Sensor; Oil Temperature - Circuit 2A	11-607
4BT2	Temperature Sensor; Discharge Temperature - Circuit 2A	11-611
4BT3	Temperature Sensor; Liquid Line Temperature Microchannel Evap - Circuit 2A	11-615
4BT4	Temperature Sensor; Evaporator Pool Temperature - Circuit 2A	11-639
4E30	Heater; Oil Separator - Circuit 2	8-393
4E31	Heater; Crankcase - Compressor 2A	8-395
4K1	Electronic Expansion Valve	11-619
4M1	Motor; Compressor 2A	3-46
4M3	Solenoid; Proportional Unload Control - Compressor 2A	8-410
4M4	Solenoid; Proportional Load Control - Compressor 2A	8-408
4M7	Solenoid; Oil - Compressor 2A	8-422
4M8	Solenoid; Step Load Control - Compressor 2A	8-419
4M11	Motor; Condenser Fan - Circuit 2	4-112
4M12	Motor; Condenser Fan - Circuit 2	4-132
4M13	Motor; Condenser Fan - Circuit 2	4-117
4M14	Motor; Condenser Fan - Circuit 2	4-137
4M15	Motor; Condenser Fan - Circuit 2	4-122
4M16	Motor; Condenser Fan - Circuit 2	4-142
4M25	Solenoid; Ckt 2 Receiver Tank	8-438
4M31	Motor; Condenser Fan - Circuit 2	4-127
4M41	Motor; Ventilation Fan 2	7-323
4T1	AFD; Compressor 2A	7-311
4T9	Choke; Circuit 1	7-305
4X1-1	Terminal Block; Junction Box - Compressor 2A	8-422
4X2-1	Terminal Block; Junction Box - Oil Separator Circuit 2	9-496
4XJ5	Jack; Ventilation Fan 2	7-322
4XJ8	Plug; AFD Controls - Compressor 2A	7-317
4XP5	Plug; Ventilation Fan 2	7-322
4XP8	Jack; AFD Controls - Compressor 2A	7-317

delete
4BP5

DEVICE	DESCRIPTION	ZONE
5K1	Relay; External Auto Stop	10-597
5K2	Relay; Chilled Water Setpoint Enable	10-577
5K3	Relay; Ice Making Control Enable	10-536
5K22	Relay; Unit Status	10-554
5K23	Relay; Unit Status	10-553
5K24	Relay; Unit Status	10-551
5K25	Relay; Unit Status	10-550
5K26	Relay; Unit Status	10-548
5K27	Relay; Unit Status	10-547
5K28	Relay; Unit Status	10-545
5K29	Relay; Unit Status	10-544
5C10	Contact; Customer Supplied Pump Control	9-467
5S1	Switch; Emergency Stop Feedback	10-593

DEVICE	DESCRIPTION	ZONE
6B1	Switch; Evaporator Water Flow	9-486
6B52	Thermostat; Antifreeze Heater	3-17
6BT1	Temperature Sensor; Outdoor Air Sensor	11-607
6BT2	Temperature Sensor; Evaporator Leaving Water Temperature	11-611
6BT3	Temperature Sensor; Evaporator Entering Water Temperature	11-615
6BT6	Temperature Sensor; Free Cooling Entering Water Temperature	11-659
6E50-1	Submersion Heater; Evaporator Shell Antifreeze Heater	3-19
6E50-2	Submersion Heater; Evaporator Shell Antifreeze Heater	3-21
6E50-5	Heat Tape; Evaporator Shell Antifreeze Heater	3-23
6E50-6	Heat Tape; Evaporator Shell Antifreeze Heater	3-25
6M3	Actuator; Bypass Modulating Valve, Total Free Cooling	9-464
6M4	Actuator; Line Modulating Valve, Total Free Cooling	9-470
6M10	Motor; Chilled Water Pump 1	3-24
6M11	Motor; Chilled Water Pump 2	3-28
6X1-1	Terminal Block; Evaporator Heater Junction Box	3-15

DEVICE PREFIX LOCATION CODE	
AREA	LOCATION
1	CONTROL PANEL
2	NOT USED
3	CIRCUIT 1
4	CIRCUIT 2
5	CUSTOMER REMOTELY INSTALLED
6	UNIT WIRING

DRAWN BY: N. SCHAMS
 © TRANE DATE: 19-NOV-2014
 MASTER FILE:
 REVISION DATE: 17-OCT-2016
 REPLACES:
 SIMILAR TO:
 USED BY:



THIS DRAWING IS PROPRIETARY AND SHALL NOT BE COPIED OR ITS CONTENTS DISCLOSED TO OUTSIDE PARTIES WITHOUT THE WRITTEN CONSENT OF TRANE

LEGEND
 RTAF
 STANDARD EFFICIENCY 270T
 HIGH EFFICIENCY 115T-250T

57226999
 SHEET 2

M

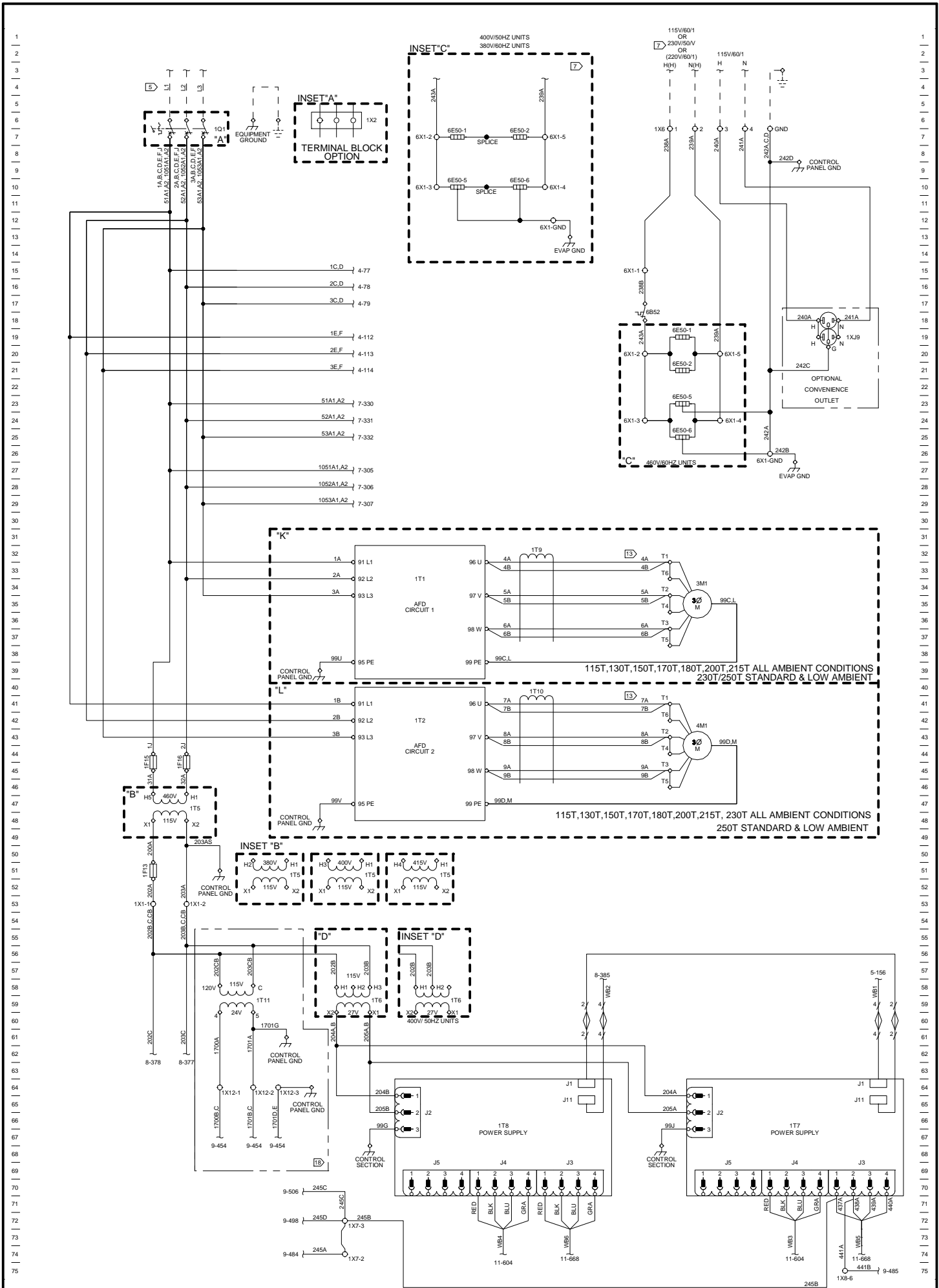

DRAWN BY: N. SCHAMS
 © TRANE DATE: 19-NOV-2014
 MASTER FILE:
 REVISION DATE: 03-MAY-2017
 REPLACES:
 SIMILAR TO:
 USED BY:

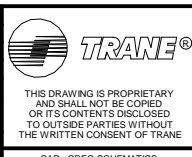

INCOMING POWER
RTAF
 STANDARD EFFICIENCY 270T
 HIGH EFFICIENCY 115T-250T
57226999
 SHEET 3



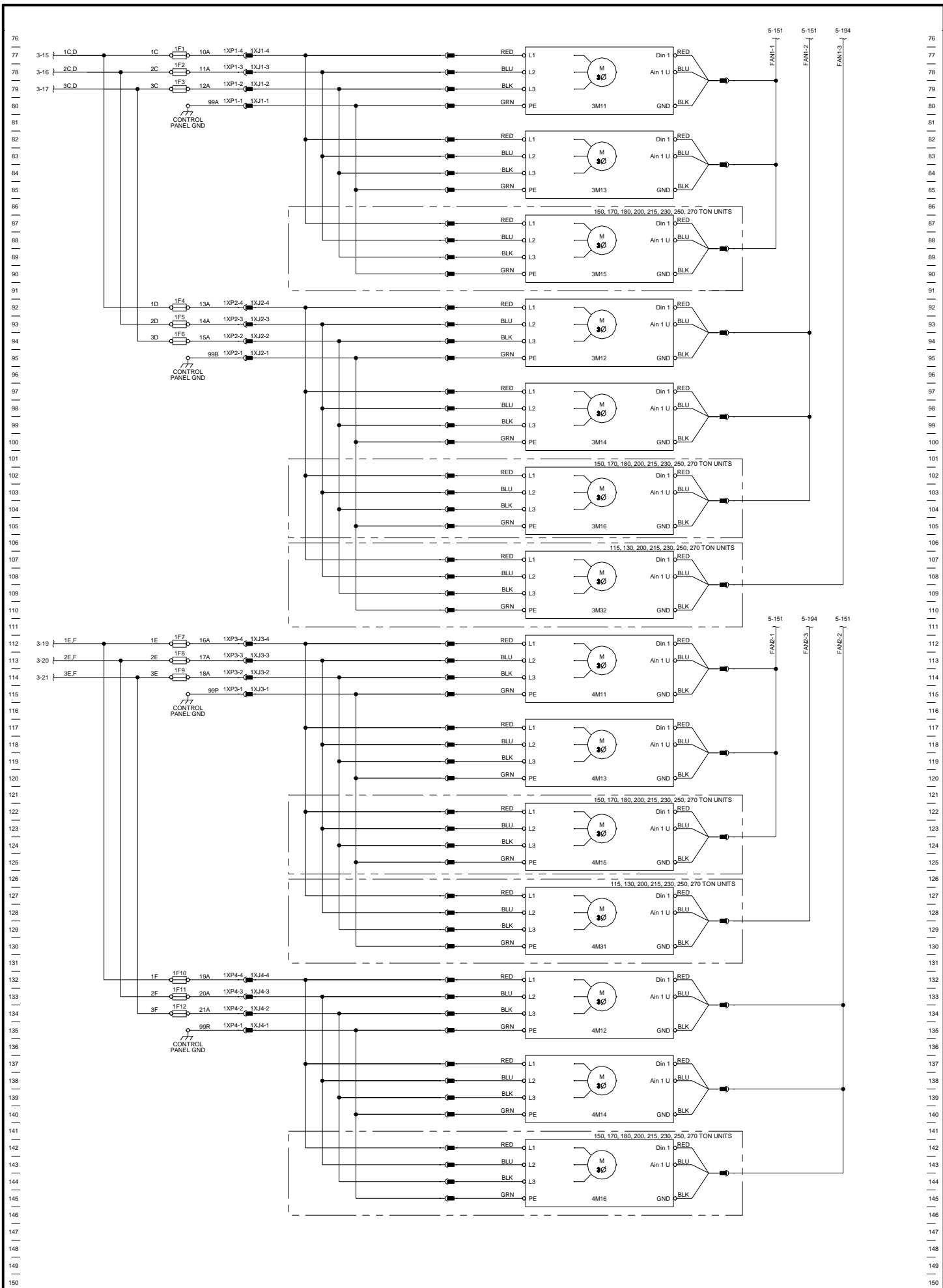

DRAWN BY: N. SCHAMS
 © TRANE DATE: 19-NOV-2014
 MASTER FILE:
 REVISION DATE: 03-MAY-2017
 REPLACES:
 SIMILAR TO:
 USED BY:

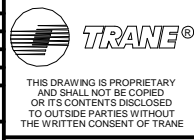

FAN POWER
 RTAF
 STANDARD EFFICIENCY 270T
 HIGH EFFICIENCY 115T-250T
57226999
 SHEET 4



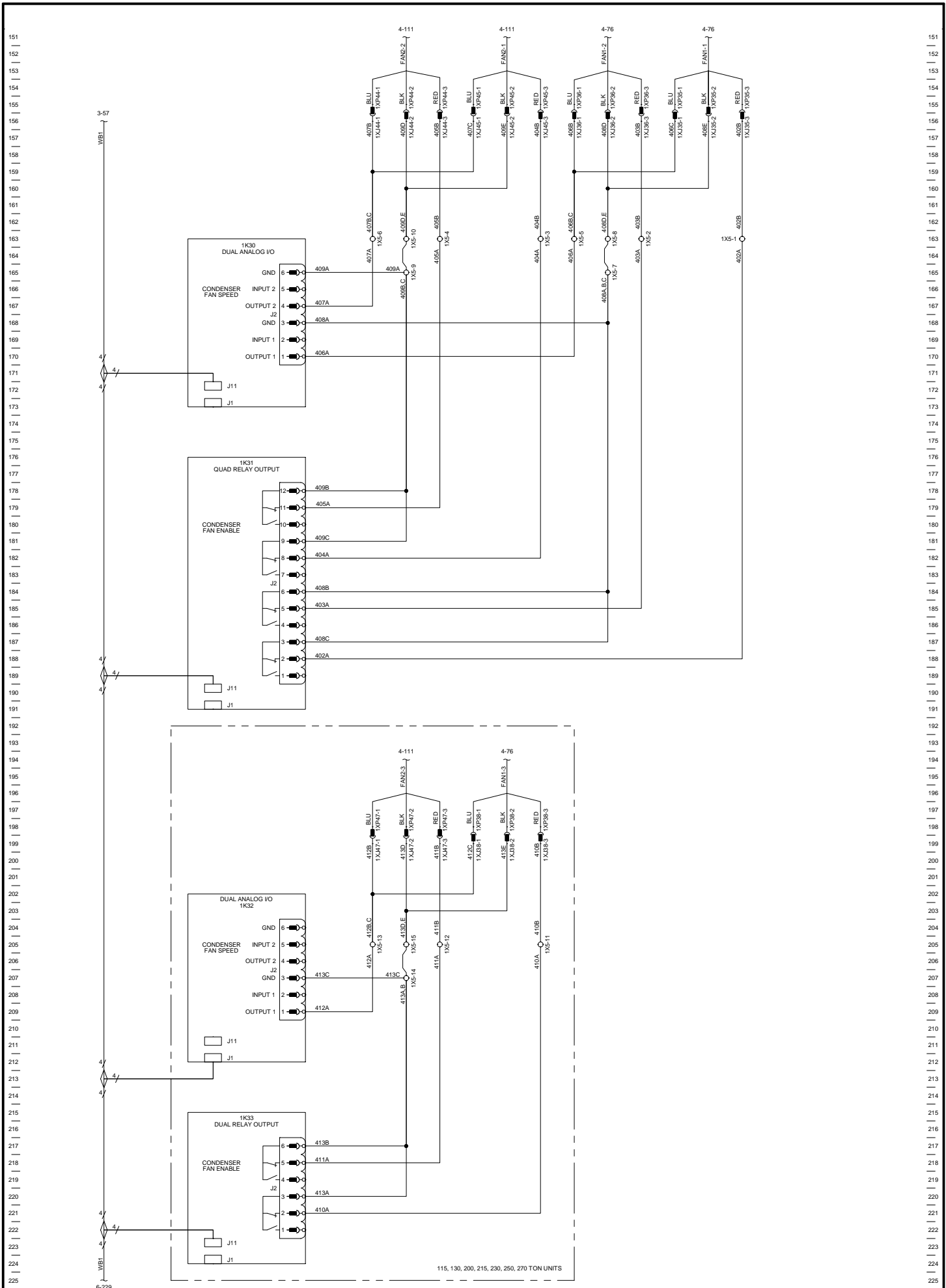

DRAWN BY: N. SCHAMS
 © TRANE DATE: 19-NOV-2014
 MASTER FILE:
 REVISION DATE: 03-MAY-2017
 REPLACES:
 SIMILAR TO:
 USED BY:

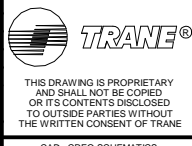

FAN CONTROLS
 RTAF
 STANDARD EFFICIENCY 270T
 HIGH EFFICIENCY 115T-250T
 57226999
 SHEET 5



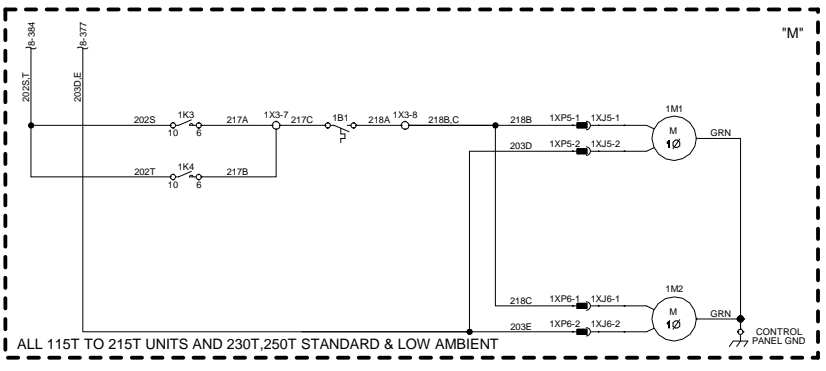
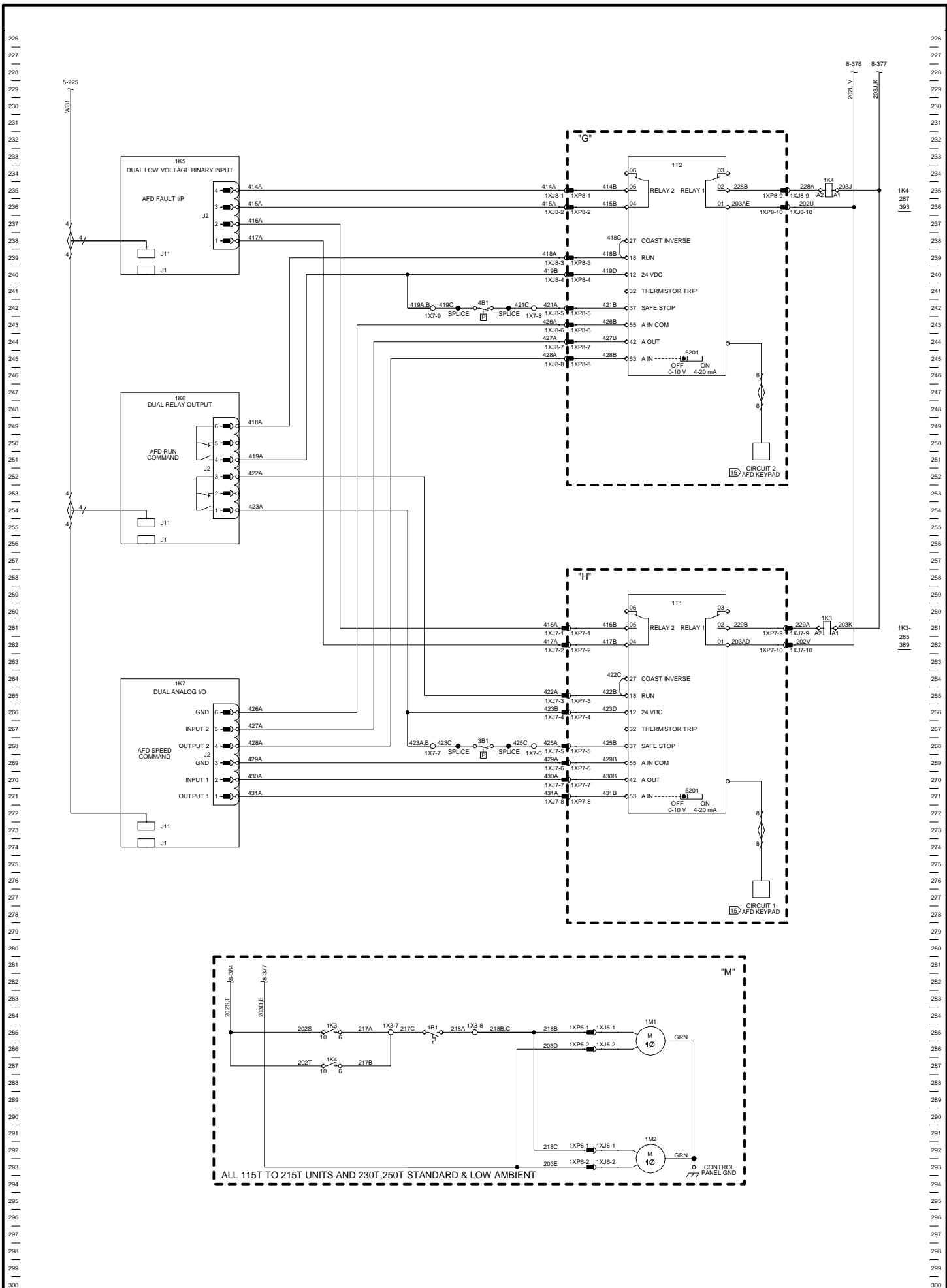

DRAWN BY:	N. SCHAMS
© TRANE DATE:	19-NOV-2014
MASTER FILE:	
REVISION DATE:	03-MAY-2017
REPLACES:	
SIMILAR TO:	
USED BY:	

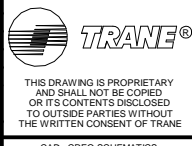

COMPRESSOR CONTROLS

RTAF

**STANDARD EFFICIENCY 270T
HIGH EFFICIENCY 115T-250T**

757226999

SHEET 6



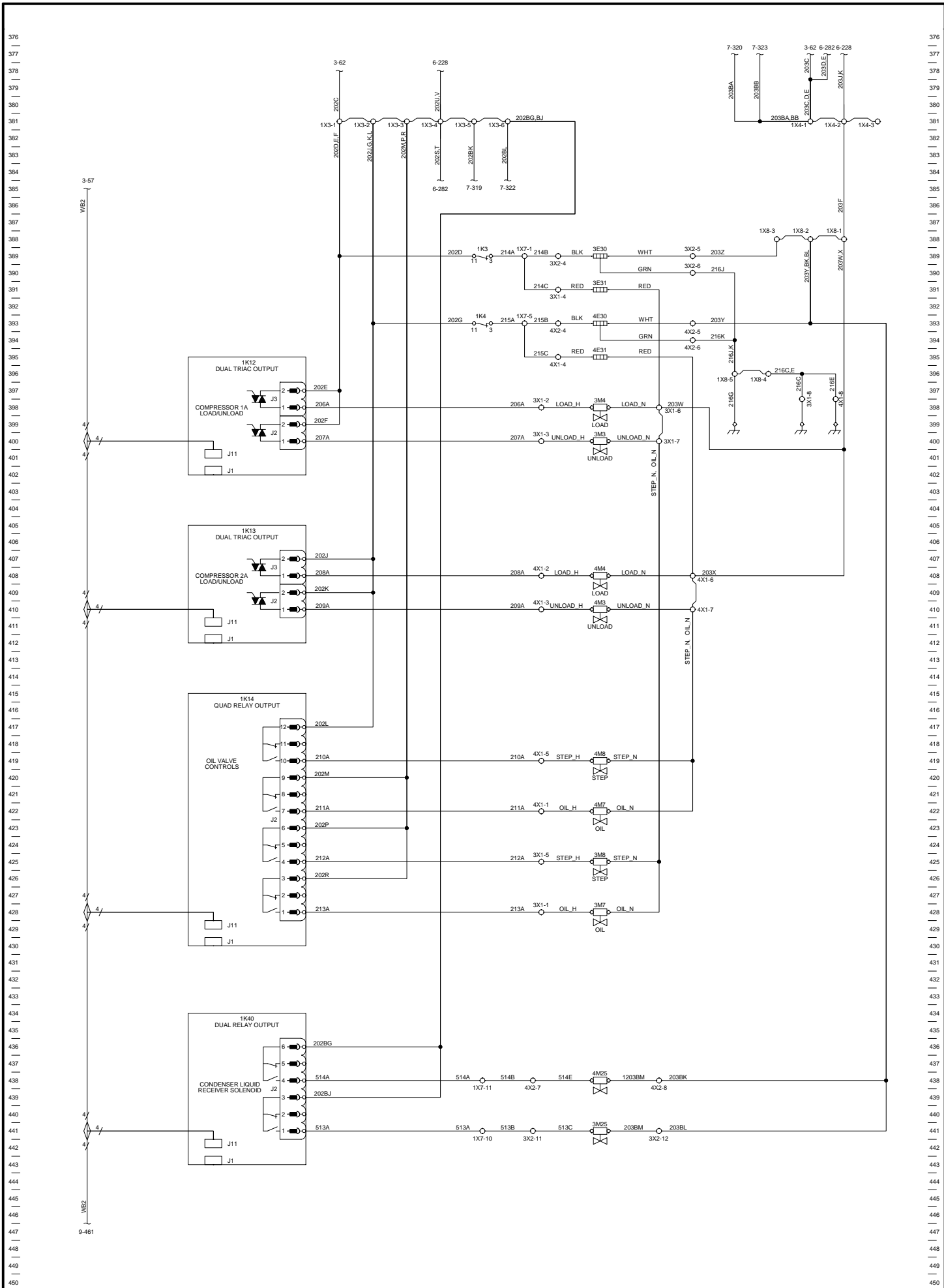

DRAWN BY:	N. SCHAMS
© TRANE DATE:	19-NOV-2014
MASTER FILE:	
REVISION DATE:	03-MAY-2017
REPLACES:	
SIMILAR TO:	
USED BY:	



THIS DRAWING IS PROPRIETARY AND SHALL NOT BE COPIED OR ITS CONTENTS DISCLOSED TO OUTSIDE PARTIES WITHOUT THE WRITTEN CONSENT OF TRANE.

CAD: CREO SCHEMATICS

OIL MANAGEMENT

RTAF

STANDARD EFFICIENCY 270T
HIGH EFFICIENCY 115T-250T

757226999

SHEET 8

REV L



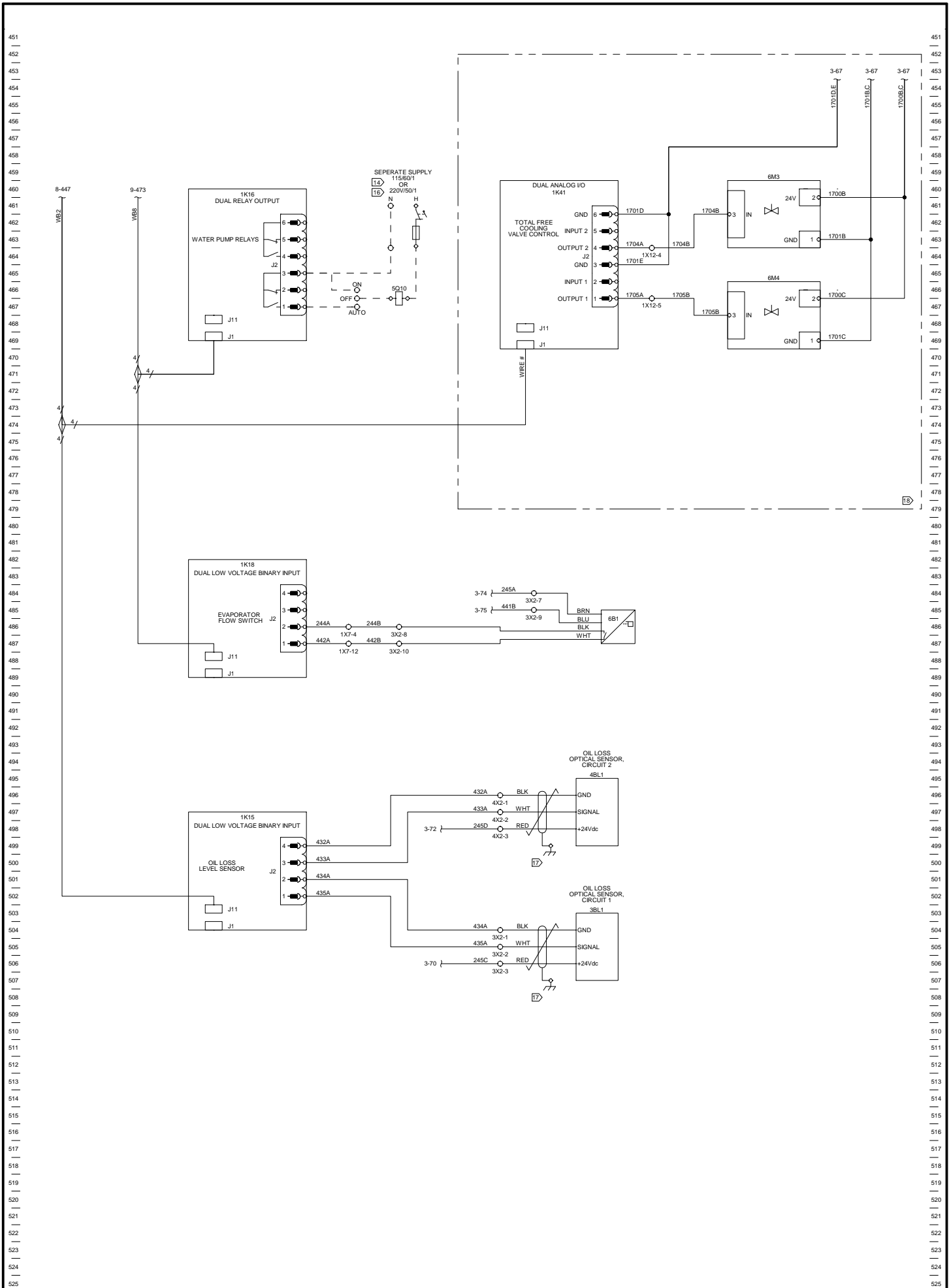

DRAWN BY:	N. SCHAMS
© TRANE DATE:	19-NOV-2014
MASTER FILE:	
REVISION DATE:	03-MAY-2017
REPLACES:	
SIMILAR TO:	
USED BY:	

TRANE
 THIS DRAWING IS PROPRIETARY AND SHALL NOT BE COPIED OR ITS CONTENTS DISCLOSED TO OUTSIDE PARTIES WITHOUT THE WRITTEN CONSENT OF TRANE.
 CAD: CREO SCHEMATICS

OIL MANAGEMENT
RTAF
 STANDARD EFFICIENCY 270T
 HIGH EFFICIENCY 115T-250T

75226999

SHEET 9



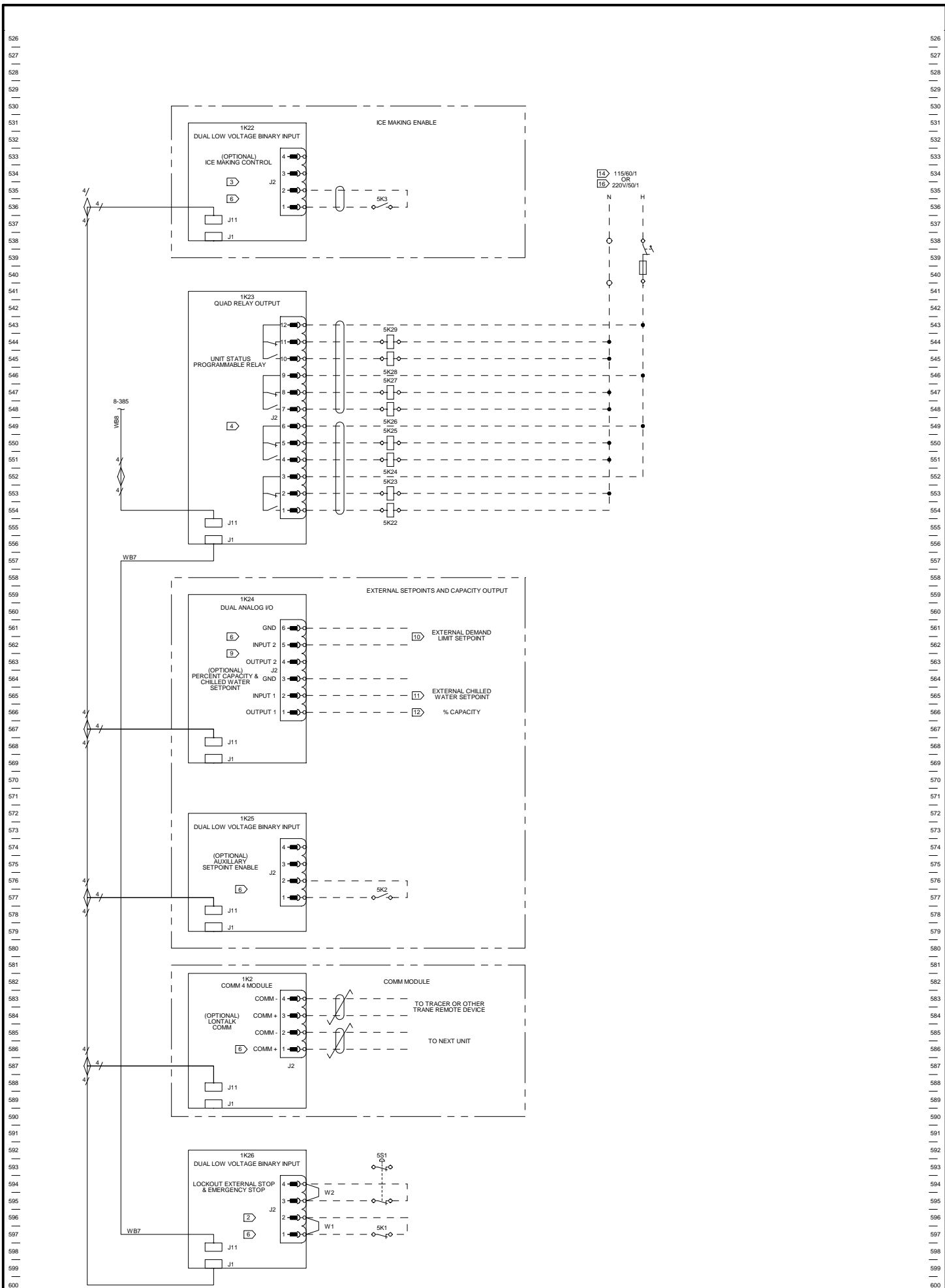

DRAWN BY: N. SCHAMS
 © TRANE DATE: 19-NOV-2014
 MASTER FILE:
 REVISION DATE: 03-MAY-2017
 REPLACES:
 SIMILAR TO:
 USED BY:

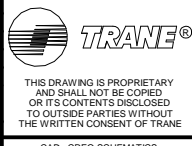

CUSTOMER CONNECTIONS
RTAF
 STANDARD EFFICIENCY 270T
 HIGH EFFICIENCY 115T-250T
57226999



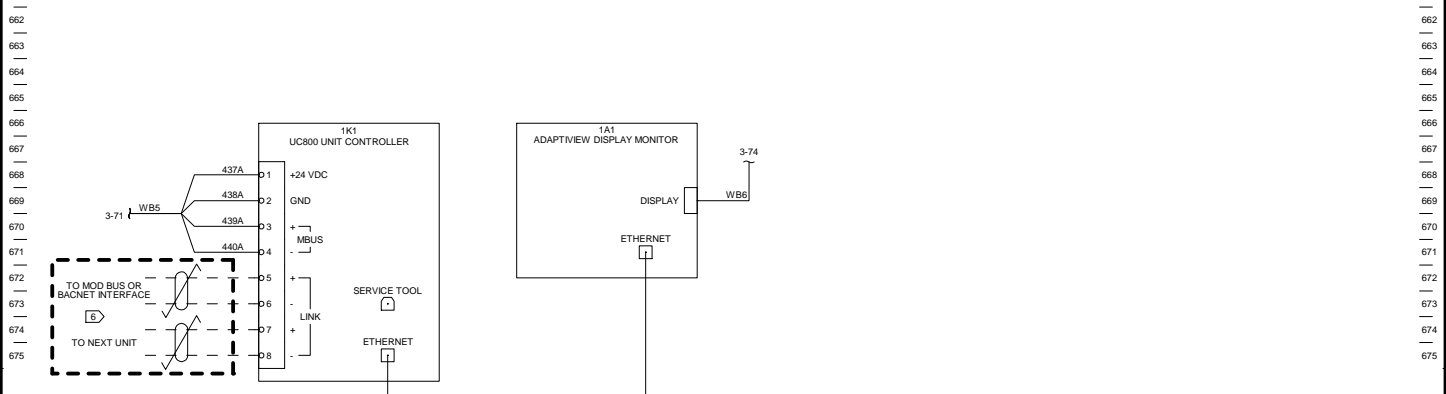
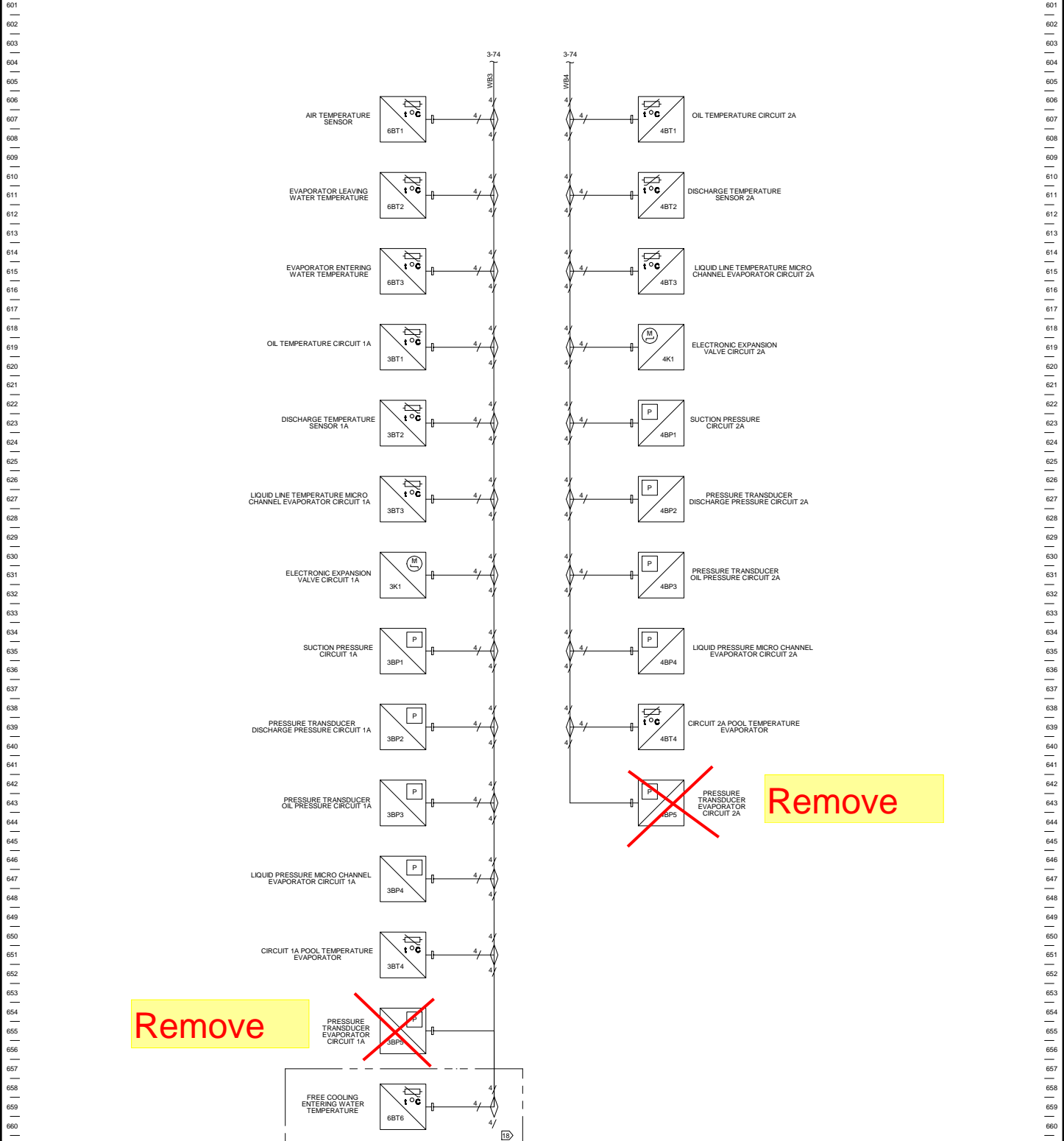

DRAWN BY: N. SCHAMS	<p>THIS DRAWING IS PROPRIETARY AND SHALL NOT BE COPIED OR ITS CONTENTS DISCLOSED TO OUTSIDE PARTIES WITHOUT THE WRITTEN CONSENT OF TRANE.</p>	UNIT SENSORS	
© TRANE DATE: 19-NOV-2014		RTAF	
MASTER FILE:		STANDARD EFFICIENCY 270T	
REVISION DATE: 03-MAY-2017		HIGH EFFICIENCY 115T-250T	
REPLACES:		57226999	
SIMILAR TO:	CAD: CREO SCHEMATICS	SHEET 11	REV L
USED BY:			

M