



TRANE®

Instruction Manual

TR200



BAS-SVX19C-EN

March 2010

BAS-SVX19C-EN

Table of Contents

Safety	1-1
High Voltage Warning.....	1-2
Before Commencing Repair Work.....	1-4
Special Conditions.....	1-4
IT Mains.....	1-5
Introduction	2-1
Mechanical Installation	3-1
Before Starting.....	3-1
How to Install.....	3-2
Mechanical Dimensions	3-3
Electrical Installation	4-1
Fuse Selection for Drives with Internal Drive Fusing.....	4-1
Fuse Replacement Table.....	4-4
How to Connect.....	4-4
Electrical Installation and Control Cables	4-6
Mains Wiring Overview	4-11
Motor Wiring Overview.....	4-20
Motor Wiring Overview.....	4-26
DC Bus Connection	4-27
Relay Connection	4-28
How to Test Motor and Direction of Rotation.....	4-32
How to Operate the Frequency Converter	5-1
How to operate graphical keypad	5-1
Tips and Tricks.....	5-10
How to program the Frequency Converter	6-1
Quick Menu Mode.....	6-1
Function Set-ups	6-11

Parameter Lists TR200.....	6-58
Default settings	6-58
0-** Operation and Display.....	6-59
1-** Load / Motor.....	6-61
2-** Brakes.....	6-63
3-** Reference / Ramps.....	6-64
4-** Limits / Warnings.....	6-66
5-** Digital In / Out.....	6-67
6-** Analog In / Out.....	6-69
8-** Communication and Options.....	6-71
11-** LonWorks.....	6-72
13-** Smart Logic Controller.....	6-73
14-** Special Functions.....	6-74
15-** Drive Information.....	6-75
16-** Data Readouts.....	6-77
18-** Info & Readouts.....	6-79
20-** Drive Closed Loop.....	6-80
21-** Ext. Closed Loop.....	6-82
22-** Application Functions.....	6-83
23-** Time Based Funtions.....	6-84
24-** Application Functions 2.....	6-85
36-** Programmable I/O Option.....	6-86
Dedicated factory settings.....	6-88
Troubleshooting.....	7-1
Alarms and Warnings.....	7-1
Fault Messages.....	7-5
Acoustic Noise or Vibration.....	7-12
Specifications.....	8-1
General Specifications.....	8-1

Special Conditions	8-11
Index	9-1

Safety

Warnings, Cautions and Notices

Note that warnings, cautions and notices appear at appropriate intervals throughout this manual. Warnings are provide to alert installing contractors to potential hazards that could result in personal injury or death. Cautions are designed to alert personnel to hazardous situations that could result in personal injury, while notices indicate a situation that could result in equipment or property-damage-only accidents.

Your personal safety and the proper operation of this machine depend upon the strict observance of these precautions.

Warnings, Cautions and Notices appear at appropriate sections throughout this literature. Read these carefully.

Indicates a potentially hazardous situation which, if not avoided, could result in death or serious injury.

Indicates a potentially hazardous situation which, if not avoided, could result in minor or moderate injury. It could also be used to alert against unsafe practices.

NOTE

Indicates a situation that could result in equipment or property-damage only accidents.

Note

Indicates something important to be noted by the reader.

★ Indicates default setting

Hazardous Voltage!

Disconnect all electric power, including remote disconnects before servicing. Follow proper lockout/tagout procedures to ensure the power can not be inadvertently energized. Failure to disconnect power before servicing could result in death or serious injury.

High Voltage Warning

The voltage of the frequency converter is dangerous whenever it is connected to mains. Incorrect installation of the motor or frequency converter could result in death, serious injury or damage to the equipment. Consequently, it is essential to comply with the instructions in this manual as well as local and national rules and safety regulations.

Safety Note

WARNING

Failure to follow instructions below could result in death or serious injury.

Safety Regulations

1. The frequency converter must be disconnected from mains if repair work is to be carried out. Check that the mains supply has been disconnected and that the necessary time has passed before removing motor and mains plugs.
2. The [STOP/RESET] key on the keypad of the frequency converter does not disconnect the equipment from mains and is thus not to be used as a safety switch.
3. Correct protective earthing of the equipment must be established, the user must be protected against supply voltage, and the motor must be protected against overload in accordance with applicable national and local regulations.
4. The earth leakage currents are higher than 3.5 mA.
5. Protection against motor overload is set by par. 1-90 [Motor Thermal Protection](#). If this function is desired, set par. 1-90 [Motor Thermal Protection](#) to data value [ETR trip] (default value) or data value [ETR warning]. Note: The function is initialized at 1.16 x rated motor current and rated motor frequency. For the North American market: The ETR functions provide class 20 motor overload protection in accordance with NEC.
6. Do not remove the plugs for the motor and mains supply while the frequency converter is connected to mains. Check that the mains supply has been disconnected and that the necessary time has passed before removing motor and mains plugs.
7. Please note that the frequency converter has more voltage inputs than L1, L2 and L3, when load sharing (linking of DC intermediate circuit) and external 24 Vdc have been installed. Check that all voltage inputs have been disconnected and that the necessary time has passed before commencing repair work.

Installation at high altitudes

380 - 500 V, enclosure A, B and C: At altitudes above 2 km (6,561 ft), please contact Trane regarding PELV/Class II.
 380 - 500 V, enclosure D, E and F: At altitudes above 3 km (9,842 ft), please contact Trane regarding PELV/Class II.
 If the drive is to be installed over 2000m (6,561 ft) altitude, then the PELV specifications are not fulfilled anymore, i.e. the distances between components and critical parts become too small. To keep anyway the clearance for functional insulation, the risk for over-voltage must be reduced by means of external protective devices or kind of galvanic isolation. De-rating should also be taken into consideration, as cooling of the drive is not so effective at high altitude. Please contact Trane in such cases.

Failure to follow recommendations could result in death or serious injury.

Warning against Unintended Start

1. The motor can be brought to a stop by means of digital commands, bus commands, references or a local stop, while the frequency converter is connected to mains. If personal safety considerations make it necessary to ensure that no unintended start occurs, these stop functions are not sufficient.
2. While parameters are being changed, the motor may start. Consequently, the stop key [STOP/RESET] must always be activated; following which data can be modified.
3. A motor that has been stopped may start if faults occur in the electronics of the frequency converter, or if a temporary overload or a fault in the supply mains or the motor connection ceases.

Consequently, disconnect all electric power, including remote disconnects before servicing. Follow proper lockout/tagout procedures to ensure the power can not be inadvertently energized. Failure to follow recommendations could result in death or serious injury.

Touching the electrical parts could result in death or serious injury - even after the equipment has been disconnected from mains.

Also make sure that other voltage inputs have been disconnected, such as external 24 Vdc, load sharing (linkage of DC intermediate circuit), as well as the motor connection for kinetic back up. Refer to the Operating Instructions for further safety guidelines.

Failure to follow recommendations could result in death or serious injury.

The frequency converter DC link capacitors remain charged after power has been disconnected. To avoid an electrical shock hazard, disconnect the frequency converter from the mains before carrying out maintenance. Wait at least as follows before doing service on the frequency converter:

Failure to follow recommendations could result in death or serious injury.

Voltage (V)	Min. Waiting Time (Minutes)				
	4	15	20	30	40
200 - 240	1.1 - 3.7 kW	5.5 - 45 kW			
380 - 480	1.1 - 7.5 kW	11 - 90 kW	110 - 250 kW		315 - 1000 kW
525 - 600	1.1 - 7.5 kW	11 - 90 kW			
525 - 690		11 - 90 kW	45 - 400 kW	450 - 1400 kW	

Be aware that there may be high voltage on the DC link even when the LEDs are turned off.

Before Commencing Repair Work

Hazardous Voltage!

1. Disconnect the frequency converter from mains
2. Disconnect DC bus terminals 88 and 89
3. Wait at least the time mentioned in section General Warning above
4. Remove motor cable

Failure to follow recommendations could result in death or serious injury.

Special Conditions

Electrical ratings:

The rating indicated on the nameplate of the frequency converter is based on a typical 3-phase mains power supply, within the specified voltage, current and temperature range, which is expected to be used in most applications.

The frequency converters also support other special applications, which affect the electrical ratings of the frequency converter.

Special conditions which affect the electrical ratings might be:

- Single phase applications
- High temperature applications which require de-rating of the electrical ratings
- Marine applications with more severe environmental conditions.

Other applications might also affect the electrical ratings.

Consult the relevant sections in this manual and in the TR200 Design Guide for information about the electrical ratings.

Installation requirements:

The overall electrical safety of the frequency converter requires special installation considerations regarding:

- Fuses and circuit breakers for over-current and short-circuit protection
- Selection of power cables (mains, motor, brake, loadsharing and relay)
- Grid configuration (grounded delta transformer leg, IT, TN, etc.)
- Safety of low-voltage ports (PELV conditions).

Consult the relevant clauses in these instructions and in the TR200 Design Guide for information about the installation requirements.

IT Mains

IT mains

Do not connect frequency converters with RFI-filters to mains supplies with a voltage between phase and earth of more than 440 V for 400 V converters and 760 V for 690 V converters.

For 400 V IT mains and delta earth (grounded leg), mains voltage may exceed 440 V between phase and earth.



For 690 V IT mains and delta earth (grounded leg), mains voltage may exceed 760 V between phase and earth.

Failure to follow recommendations could result in death or serious injury.

Par. 14-50 [RFI 1](#) can be used to disconnect the internal RFI capacitors from the RFI filter to ground.

Software Version and Approvals: TR200

TR200
Software version:3.1x



This manual can be used with all TR200 frequency converters with software version 3.1x
The software version number can be seen from par. 15-43 [Software Version](#).

Disposal Instruction

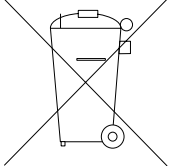

Equipment containing electrical components must not be disposed of together with domestic waste.
It must be separately collected with electrical and electronic waste according to local and currently valid legislation.

Introduction

Available Literature for TR200

- Operating Instructions provide the necessary information for getting the drive up and running.
- Operating Instructions TR200 High Power
- Design Guide entails all technical information about the drive and customer design and applications.
- Programming Guide provides information on how to program and includes complete parameter descriptions.

x = Revision number

yy = Language code

Trane technical literature is available in print from your local Trane Sales Office or online at:

www.trane.com/vfd

Abbreviations and Standards

Abbreviations:	Terms:	SI-units:	I-P units:
a	Acceleration	m/s ²	ft/s ²
AWG	American wire gauge		
Auto Tune	Automatic Motor Tuning		
°C	Celsius		
I	Current	A	Amp
I _{LIM}	Current limit		
IT mains	Mains supply with star point in transformer floating to ground.		
Joule	Energy	J = N·m	ft-lb, Btu
°F	Fahrenheit		
FC	Frequency Converter		
f	Frequency	Hz	Hz
kHz	Kilohertz	kHz	kHz
keypad	Local Control Panel		
mA	Milliamperere		
ms	Millisecond		
min	Minute		
	Control Tool		
M-TYPE	Motor Type Dependent		
Nm	Newton Metres		in-lbs
I _{M,N}	Nominal motor current		
f _{M,N}	Nominal motor frequency		
P _{M,N}	Nominal motor power		
U _{M,N}	Nominal motor voltage		
par.	Parameter		
PELV	Protective Extra Low Voltage		
Watt	Power	W	Btu/hr, hp
Pascal	Pressure	Pa = N/m ²	psi, psf, ft of water
I _{INV}	Rated Inverter Output Current		
RPM	Revolutions Per Minute		
SR	Size Related		
T	Temperature	C	F
t	Time	s	s,hr
T _{LIM}	Torque limit		
U	Voltage	V	V

Table 2. 1: Abbreviation and standards table

Frequency Converter Identification

Below is an example of an identification label. This label is situated on the frequency converter and shows the type and options fitted to the unit. See below for details of how to read the Type code string (T/C).

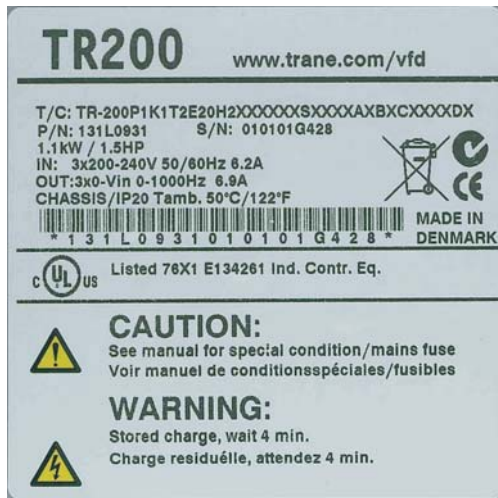

130BA489.10

Figure 2. 1: This example shows an identification label.

Please have T/C (type code) number and serial number ready before contacting Trane.

Type Code String low and medium power

1	2	3	4	5	6	7	8	9	10	11	12	13	14	15	16	17	18	19	20	21	22	23	24	25	26	27	28	29	30	31	32	33	34	35	36	37	38	39
TR-				2	0	0	P				T												X	S	X	X	X	A	B	C								D

130BA052.15

Description	Pos	Possible choice
Product group & FC Series	1-6	TR-200
Power rating	8-10	1.1- 1200 kW (P1K1 - P1M2)
Number of phases	11	Three phases (T)
Mains voltage	11-12	T 2: 200-240 VAC T 4: 380-480 VAC
Enclosure	13-15	E20: IP20 E21: IP 21/NEMA Type 1 E55: IP 55/NEMA Type 12 E66: IP66 P21: IP21/NEMA Type 1 w/backplate P55: IP55/NEMA Type 12 w/backplate
RFI filter	16-17	H1: RFI filter class A1/B H2: RFI filter class A2 H3: RFI filter class A1/B (reduced cable length) Hx: No RFI filter
Brake	18	X: No brake chopper included
Display	19	G: Graphical Local Control Panel (keypad) X: No Local Control Panel
Coating PCB	20	X: No coated PCB C: Coated PCB
Mains option	21	X: No Mains disconnect switch and Load Sharing 1: With Mains disconnect switch (IP55 only) 8: Mains disconnect and Load Sharing D: Load Sharing See Chapter 8 for max. cable sizes.
Adaptation	22	X: Standard 0: European metric thread in cable entries.
Adaptation	23	Reserved
Software release	24-27	Actual software
Software language	28	
A options	29-30	AX: No options A4: MCA 104 DeviceNet AF: MCA 115 LonWorks AE: MCA 116 BACnet gateway
B options	31-32	BX: No option BK: MCB 101 General purpose I/O option BP: MCB 105 Relay option
C0 options MCO	33-34	CX: No options
C1 options	35	X: No options
C option software	36-37	XX: Standard software
D options	38-39	DX: No option D0: DC back-up

Table 2. 2: Type code description.

Mechanical Installation

Before Starting

Checklist

When unpacking the frequency converter, ensure that the unit is undamaged and complete. Use the following table to identify the packaging:

Enclosure type:	A2 (IP 20-21)	A3 (IP 20-21)	A4 (IP 55-66)	A5 (IP 55-66)	B1/B3 (IP 20-21-55-66)	B2/B4 (IP 20-21-55-66)	C1/C3 (IP 20-21-55-66)	C2*/C4 (IP 20-21-55-66)
	 130BA295:10							
Unit size (kW):								
200-240 V	1.1-2.2	3.0-3.7	1.1-2.2	1.1-3.7	5.5-11/ 5.5-11	15/ 15-18.5	18.5-30/ 22-30	37-45/ 37-45
380-480 V	1.1-4.0	5.5-7.5	1.1-4.0	1.1-7.5	11-18.5/ 11-18.5	22-30/ 22-37	37-55/ 45-55	75-90/ 75-90
525-600 V		1.1-7.5		1.1-7.5	11-18.5/ 11-18.5	22-30/ 22-37	37-55/ 45-55	75-90/ 75-90

Table 3. 1: Unpacking table

Please note that a selection of screwdrivers (phillips or cross-thread screwdriver and torx), a side-cutter, drill and knife is also recommended to have handy for unpacking and mounting the frequency converter. The packaging for these enclosures contains, as shown: Accessories bag(s), documentation and the unit. Depending on options fitted there may be one or two bags and one or more booklets.

How to Install

Mechanical Front Views

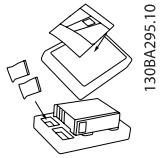
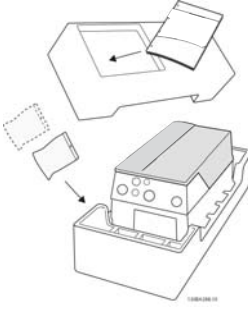
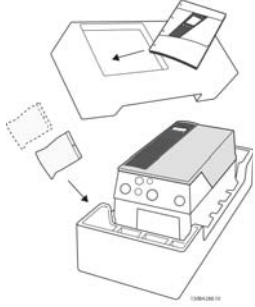
A2	A3	A4	A5	B1	B2
IP20/21*	IP20/21*	IP55/66	IP55/66	IP21/55/66	IP21/55/66
<p>Top and bottom mounting holes.</p>					
B3	B4	C1	C2	C3	C4
IP20/21*	IP20/21*	IP21/55/66	IP21/55/66	IP20/21*	IP20/21*
<p>Top and bottom mounting holes. (B4+C3+C4 only)</p>					
<p>Accessory bags containing necessary brackets, screws and connectors are included with the drives upon delivery.</p>					
<p>* IP21 can be established with a kit as described in the section: IP 21/ IP 4X/ TYPE 1 Enclosure Kit in the Design Guide.</p>					

Mechanical Dimensions

Frame size (kW):	Mechanical Dimensions											
	A2	A3	A4	A5	B1	B2	B3	B4	C1	C2	C3	C4
200-240 V	1.1-2.2	3.0-3.7	1.1-2.2	1.1-3.7	5.5-11	15	5.5-11	15-18.5	18.5-30	37-45	22-30	37-45
380-480 V	1.1-4.0	5.5-7.5	1.1-4.0	1.1-7.5	11-18.5	22-30	11-18.5	22-37	37-55	75-90	45-55	75-90
525-600 V		1.1-7.5		1.1-7.5	11-18.5	22-30	11-18.5	22-37	37-55	75-90	45-55	75-90
IP	20	21	55/66	55/66	21/55/66	21/55/66	20	20	21/55/66	21/55/66	20	20
NEMA	Chassis Type 1 Chassis Type 1 Type 12 Type 1/12 Chassis Type 1/12 Type 1/12 Chassis Type 1/12 Chassis											
Height (mm)												
Enclosure	A**	246	372	390	420	480	650	350	460	680	770	490
..with de-coupling plate	A2	374	-	374	-	-	-	419	595	-	-	630
Back plate	A1	268	375	390	420	480	650	399	520	680	770	550
Distance between mount. holes	a	257	350	401	402	454	624	380	495	648	739	521
Width (mm)												
Enclosure	B	90	90	130	242	242	242	165	231	308	370	370
With one C option	B	130	170	170	242	242	242	205	231	308	370	370
Back plate	B	90	90	130	242	242	242	165	231	308	370	370
Distance between mount. holes	b	70	110	171	215	210	210	140	200	272	334	270
Depth (mm)												
Without option A/B	C	205	205	175	200	260	260	248	242	310	335	333
With option A/B	C*	220	220	175	200	260	260	262	242	310	335	333
Screw holes (mm)												
c	8.0	8.0	8.0	8.2	8.2	12	12	8	-	12	12	-
d	11	11	11	12	12	19	19	12	-	19	19	-
Diameter ø	e	5.5	5.5	6.5	6.5	9	9	6.8	8.5	9.0	9.0	8.5
Diameter ø	f	9	9	6	9	9	9	7.9	15	9.8	9.8	17
Max weight (kg)												
	4.9	5.3	6.6	7.0	9.7	14	23	12	23.5	45	65	50

* Depth of enclosure will vary with different options installed.

** The free space requirements are above and below the bare enclosure height measurement A. See section *Mechanical Mounting* for further information.

Accessory Bags

Accessory Bags: Find the following parts included in the frequency converter accessory bags

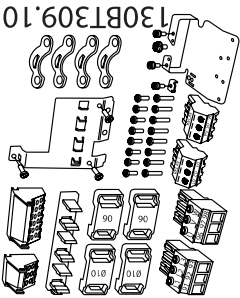
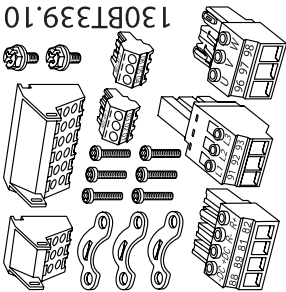
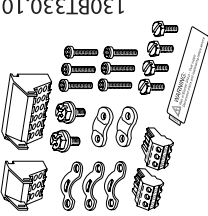
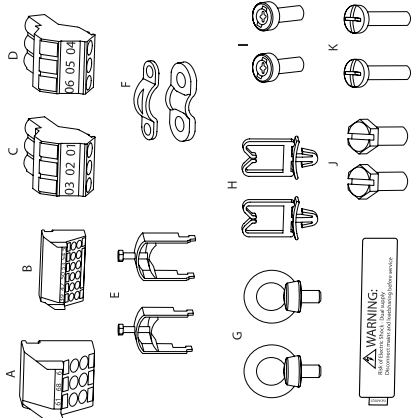
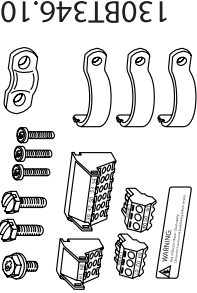
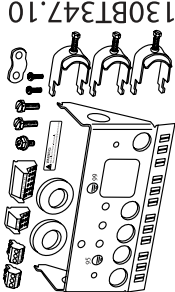
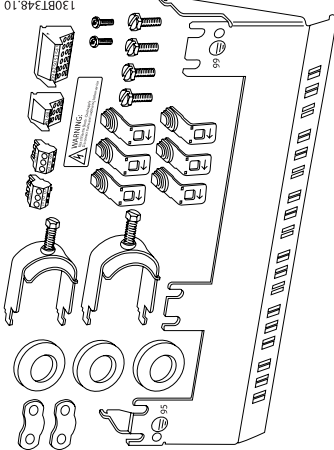
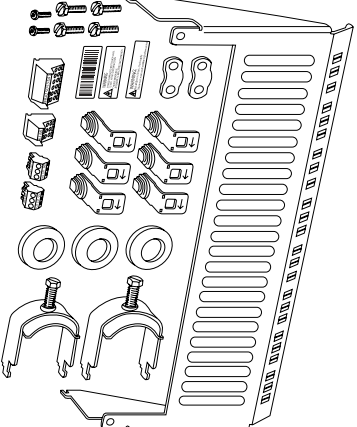
 <p>130B1309.10</p>	 <p>130B1339.10</p>	 <p>130B1330.10</p>	 <p>130B1406.10</p>
 <p>130B1346.10</p>	 <p>130B1347.10</p>	 <p>130B1348.10</p>	 <p>130B1349.10</p>
<p>Frame sizes A1, A2 and A3</p>	<p>Frame size A5</p>	<p>Frame sizes B1 and B2</p>	<p>Frame sizes C1 and C2</p>
<p>Frame size B3</p>	<p>Frame size B4</p>	<p>Frame size C3</p>	<p>Frame size C4</p>
<p>1 + 2 only available in units with brake chopper. For DC link connection (Load sharing) the connector 1 can be ordered separately (Code no. 130B1064)</p>			

Mechanical Mounting

All IP20 enclosure sizes as well as IP21/ IP55 enclosure sizes except A2 and A3 allow side-by-side installation.

If the IP 21 Enclosure kit (130B1122 or 130B1123) is used on enclosure A2 or A3, there must be a clearance between the drives of min. 50 mm.

For optimal cooling conditions allow a free air passage above and below the frequency converter. See table below.

Air passage for different enclosures

Enclosure:	A2	A3	A4	A5	B1	B2	B3	B4	C1	C2	C3	C4
a (mm):	100	100	100	100	200	200	200	200	200	225	200	225
b (mm):	100	100	100	100	200	200	200	200	200	225	200	225

1. Drill holes in accordance with the measurements given.
2. You must provide screws suitable for the surface on which you want to mount the frequency converter. Retighten all four screws.

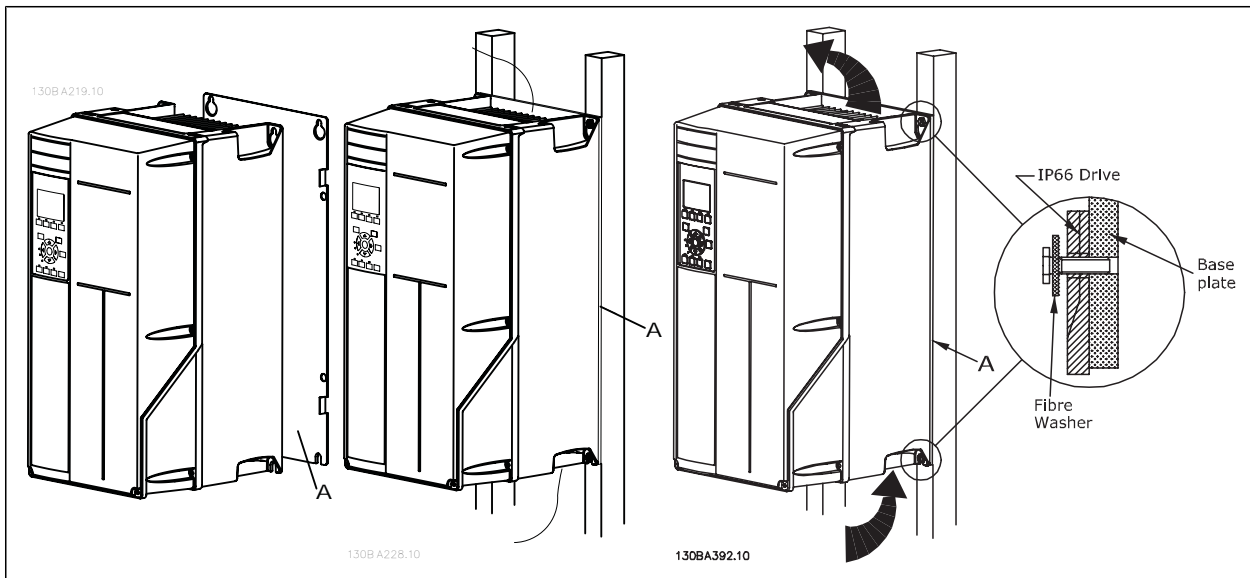

Mounting frame sizes A4, A5, B1, B2, B3, B4, C1, C2, C3 and C4 on a non-solid back wall, the frequency converter must be provided with a backplate A due to insufficient cooling air over the heat sink.

With heavier drives (B4, C3, C4) use a lift. First wall-mount the 2 lower bolts - then lift the drive onto the lower bolts - finally fasten the drive against the wall with the 2 top bolts.

Safety Requirements of Mechanical Installation

WARNING

Pay attention to the requirements that apply to integration and field mounting kit. Observe the information in the list to avoid serious injury or equipment damage, especially when installing large units.

NOTE

The frequency converter is cooled by means of air circulation.

To protect the unit from overheating, it must be ensured that the ambient temperature *does not exceed the maximum temperature stated for the frequency converter* and that the 24-hour average temperature *is not exceeded*. Locate the maximum temperature and 24-hour average in the paragraph *Derating for Ambient Temperature*.

If the ambient temperature is in the range of 45 °C - 55 ° C, derating of the frequency converter will become relevant, see *Derating for Ambient Temperature*.

The service life of the frequency converter is reduced if derating for ambient temperature is not taken into account.

Field Mounting

For field mounting the IP 21/IP 4X top/TYPE 1 kits or IP 54/55 units are recommended.

Electrical Installation

Fuse Selection for Drives with Internal Drive Fusing

For drives ordered with internal drive fusing

The illustrations below show where input mains power, output motor power, and relays are located for drives with internal fusing. Replacement fuse ratings for internal fuses are also provided.

1. Relay terminals
2. Motor power terminals
3. Input power terminals

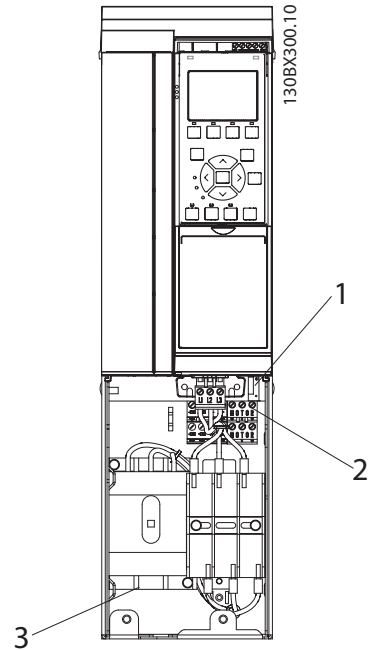

Figure 4. 1: A2, A3

1. Drive fuses
2. Relay terminals
3. Motor power terminals
4. Input power terminals

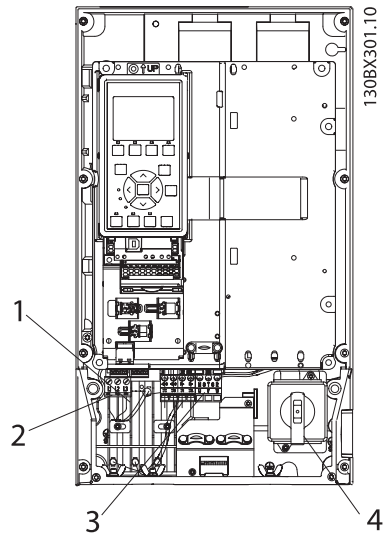

Figure 4. 2: A5

For B1 and B2 frame sizes, motor and relay connections are located under the drive fuse block. To access these connectors, loosen 3 T-20 screws and move fuse block out of the way. The fuse block does not need to be disassembled

1. Loosen screws
2. Drive fuses
3. Motor power terminals (remove fuse plate to connect)
4. Relay terminals
5. Input power terminals

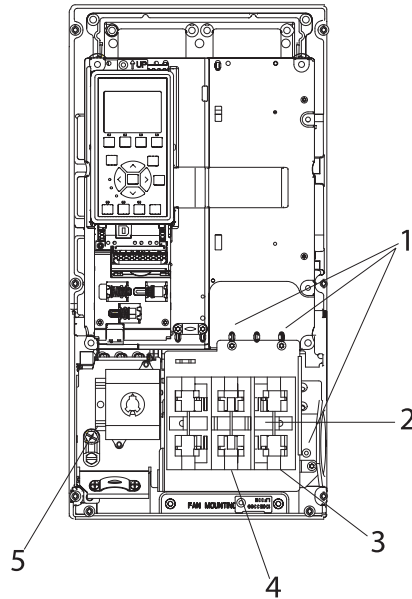

Figure 4. 3: B1

1. Loosen screws
2. Drive fuses
3. Relay terminals
4. Input power terminals
5. Motor power terminals (remove fuse plate to connect)

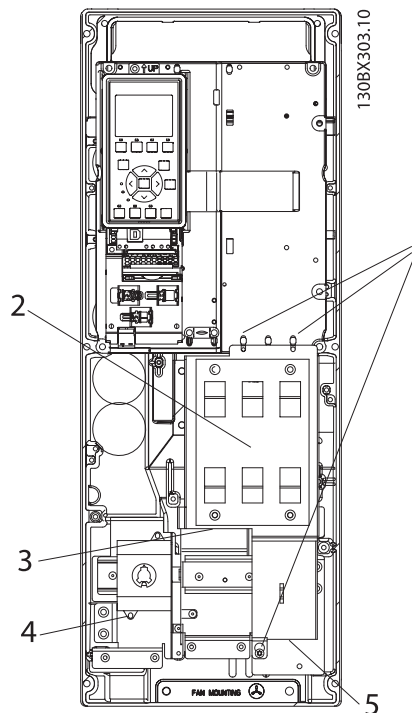

Figure 4. 4: B2

1. Relay terminals
2. Drive fuses
3. Motor power terminals
4. Input power terminals

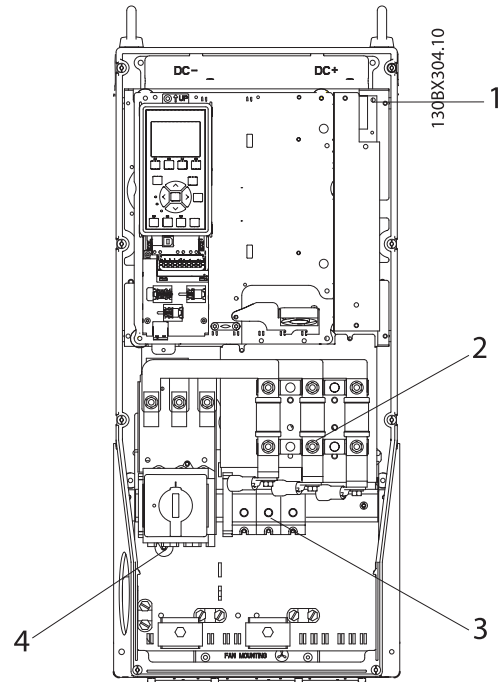

Figure 4.5: C1

1. Relay terminals
2. Drive fuses
3. Motor power terminals
4. Input power terminals

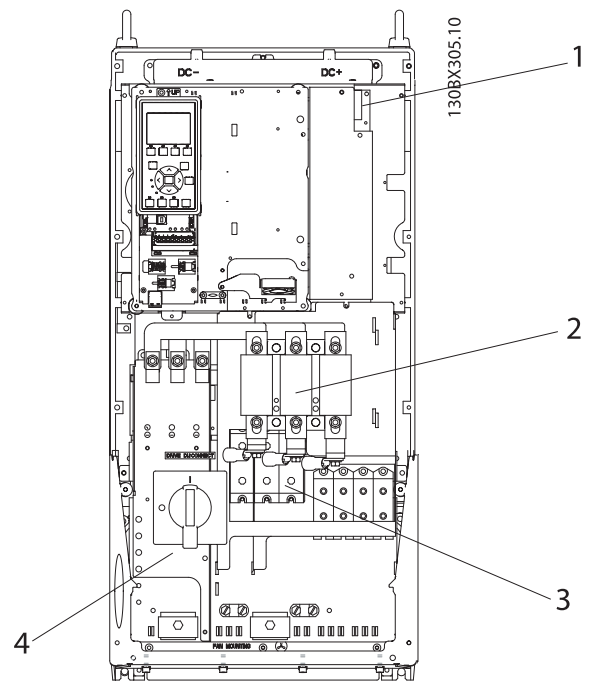

Figure 4.6: C2

Fuse Replacement Table

Drive Rating TR200				
HP	kW	208-230V	460-480V	575-600V
1.5	1.1	LP-CC-10 10A, 600V Class CC	LP-CC-6 6A, 600V, Class CC	LP-CC-5 5A, 600V, Class CC
2	1.5	LP-CC-15 15A, 600V Class CC	LP-CC-10 10A, 600V, Class CC	LP-CC-10 10A, 600V, Class CC
3	2.2	LP-CC-20 20A, 600V Class CC	LP-CC-10 10A, 600V, Class CC	LP-CC-10 10A, 600V, Class CC
5	3.7/4	LP-CC-30 30A, 600V Class CC	LP-CC-20 20A, 600V, Class CC	LP-CC-20 20A, 600V, Class CC
7.5	5.5	JJN-50 50A, 300V, Class T	LP-CC-25 25A, 600V, Class CC	LP-CC-25 25A, 600V, Class CC
10	7.5	JJN-50 50A, 300V, Class T	LP-CC-30 30A, 600V, Class CC	LP-CC-30 30A, 600V, Class CC
15	11	JJN-60 60A, 300V, Class T	JJS-40 40A, 600V, Class T	JJS-35 35A 600V Class T
20	15	JJN-80 80A, 300V, Class T	JJS-40 40A, 600V, Class T	JJS-35 35A 600V Class T
25	18.5	JJN-125 125A, 300V, Class T	JJS-50 50A, 600V, Class T	JJS-45 45A 600V Class T
30	22	JJN-125 125A, 300V, Class T	JJS-60 60A, 600V, Class T	JJS-50 50A 600V Class T
40	30	FWX-150A 150A, 250V	JJS-80 80A, 600V, Class T	JJS-60 60A 600V Class T
50	37	FWX-200A 200A, 250V	JJS-100 100A, 600V, Class T	JJS-80 80A 600V Class T
60	45	FWX-250A 250A, 250V	JJS-125 125A, 600V, Class T	JJS-100 100A 600V Class T
75	55	n/a	JJS-150 150A, 600V, Class T	JJS-125 125A 600V Class T
100	75	n/a	FWH-200B 200A, 500V	JJS-150 150A 600V Class T
125	90	n/a	FWH-250A 250A, 500V	JJS-175 175A 600V Class T

How to Connect

Cables General

For the TR200 High Power series mains and motor connections, please see TR200 *High Power Operating Instructions*.

Cables General

All cabling must comply with national and local regulations on cable cross-sections and ambient temperature. Copper (60/75 °C) conductors are recommended.

Details of terminal tightening torques.

Enclosure	Power (kW)			Torque (Nm)					
	200-240V	380-480V	525-600 V	Mains	Motor	DC connection	Brake	Earth	Relay
A2	1.1 - 3.0	1.1 - 4.0	1.1 - 4.0	1.8	1.8	1.8	1.8	3	0.6
A3	3.7	5.5 - 7.5	5.5 - 7.5	1.8	1.8	1.8	1.8	3	0.6
A4	1.1-2.2	1.1-4		1.8	1.8	1.8	1.8	3	0.6
A5	1.1 - 3.7	1.1 - 7.5	1.1 - 7.5	1.8	1.8	1.8	1.8	3	0.6
B1	5.5 - 11	11 - 18.5	11 - 18.5	1.8	1.8	1.5	1.5	3	0.6
B2	-	22	22	4.5	4.5	3.7	3.7	3	0.6
	15	30	30	4.5 ²⁾	4.5 ²⁾	3.7	3.7	3	0.6
B3	5.5 - 11	11 - 18.5	11 - 18.5	1.8	1.8	1.8	1.8	3	0.6
B4	15 - 18.5	22 - 37	22 - 37	4.5	4.5	4.5	4.5	3	0.6
C1	18.5 - 30	37 - 55	37 - 55	10	10	10	10	3	0.6
C2	37 - 45	75 - 90	75 - 90	14/24 ¹⁾	14/24 ¹⁾	14	14	3	0.6
C3	22 - 30	45 - 55	45 - 55	10	10	10	10	3	0.6
C4	37 - 45	75 - 90	75 - 90	14/24 ¹⁾	14/24 ¹⁾	14	14	3	0.6
High Power									
Enclosure		380-480 V		Mains	Motor	DC connection	Brake	Earth	Relay
D1/D3		110-132		19	19	9.6	9.6	19	0.6
D2/D4		160-250		19	19	9.6	9.6	19	0.6
E1/E2		315-450		19	19	19	9.6	19	0.6
F1-F3 ³⁾		500-710	710-900	19	19	19	9.6	19	0.6
F2-F4 ³⁾		800-1000	1000-1400	19	19	19	9.6	19	0.6

Table 4. 1: Tightening of terminals

- 1) For different cable dimensions x/y, where $x \leq 95 \text{ mm}^2$ and $y \geq 95 \text{ mm}^2$.
- 2) Cable dimensions above $18.5 \text{ kW} \geq 35 \text{ mm}^2$ and below $22 \text{ kW} \leq 10 \text{ mm}^2$.
- 3) For data on the F frame sizes consult TR200 High Power Operating Instructions.

Electrical Installation and Control Cables

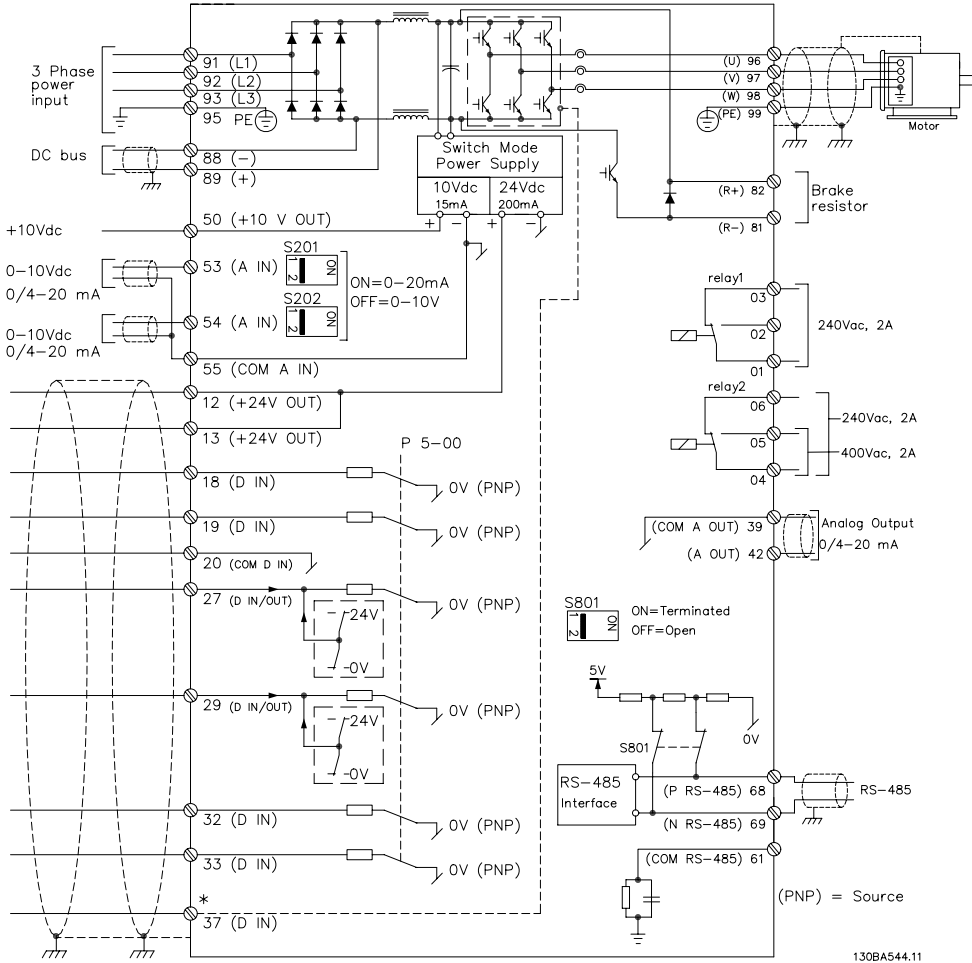

Figure 4. 7: Diagram showing all electrical terminals.

Terminal number	Terminal description	Parameter number	Factory default
1+2+3	Terminal 1+2+3-Relay1	5-40	No operation
4+5+6	Terminal 4+5+6-Relay2	5-40	No operation
12	Terminal 12 Supply	-	+24 Vdc
13	Terminal 13 Supply	-	+24 Vdc
18	Terminal 18 Digital Input	5-10	Start
19	Terminal 19 Digital Input	5-11	No operation
20	Terminal 20	-	Common
27	Terminal 27 Digital Input/Output	5-12/5-30	Coast inverse
29	Terminal 29 Digital Input/Output	5-13/5-31	Jog
32	Terminal 32 Digital Input	5-14	No operation
33	Terminal 33 Digital Input	5-15	No operation
42	Terminal 42 Analog Output	6-50	Speed 0-HighLim
53	Terminal 53 Analog Input	3-15/6-1*/20-0*	Reference
54	Terminal 54 Analog Input	3-15/6-2*/20-0*	Feedback

Table 4. 2: Terminal connections

Very long control cables and analog signals may, in rare cases and depending on installation, result in 50/60 Hz earth loops due to noise from mains supply cables.

If this occurs, break the screen or insert a 100 nF capacitor between screen and chassis.

The common of digital / analog inputs and outputs should be connected to separate common terminals 20, 39, and 55. This will avoid ground current interference among groups. For example, it avoids switching on digital inputs disturbing analog inputs.

Control cables must be screened/armoured.

Fuses

Branch Circuit Protection

WARNING

In order to protect the installation against electrical and fire hazard, all branch circuits in an installation, switch gear, machines etc., must be short-circuit and over-current protected according to NEC and your local/state code. Failure to follow recommendations could result in death or serious injury.

Short-circuit protection:

The frequency converter must be protected against short-circuit to avoid electrical or fire hazard. Trane recommends using the fuses mentioned below to protect service personnel and equipment in case of an internal failure in the drive. The frequency converter provides full short-circuit protection in case of a short-circuit on the motor output.

WARNING

Overcurrent protection:

Provide overload protection to avoid fire hazard due to overheating of the cables in the installation. Fuses or circuit breakers can be used to provide the over-current protection in the installation. Over-current protection must always be carried out according to NEC and your local/state code.

NOTE

Note Fusing not in UL compliance

If UL/cUL is not to be complied with, Trane recommends using the fuses mentioned in the table below, which will ensure compliance with EN50178.

In case of malfunction, not following the recommendation may result in unnecessary damage to the frequency converter.

UL compliance/non-compliance
Non-UL compliance fuses

Frequency converter	Max. fuse size	Voltage	Type
200-240 V - T2			
1K1-1K5	16A ¹	200-240 V	type gG
2K2	25A ¹	200-240 V	type gG
3K0	25A ¹	200-240 V	type gG
3K7	35A ¹	200-240 V	type gG
5K5	50A ¹	200-240 V	type gG
7K5	63A ¹	200-240 V	type gG
11K	63A ¹	200-240 V	type gG
15K	80A ¹	200-240 V	type gG
18K5	125A ¹	200-240 V	type gG
22K	125A ¹	200-240 V	type gG
30K	160A ¹	200-240 V	type gG
37K	200A ¹	200-240 V	type aR
45K	250A ¹	200-240 V	type aR
380-480 V - T4			
1K1-1K5	10A ¹	380-500 V	type gG
2K2-3K0	16A ¹	380-500 V	type gG
4K0-5K5	25A ¹	380-500 V	type gG
7K5	35A ¹	380-500 V	type gG
11K-15K	63A ¹	380-500 V	type gG
18K	63A ¹	380-500 V	type gG
22K	63A ¹	380-500 V	type gG
30K	80A ¹	380-500 V	type gG
37K	100A ¹	380-500 V	type gG
45K	125A ¹	380-500 V	type gG
55K	160A ¹	380-500 V	type gG
75K	250A ¹	380-500 V	type aR
90K	250A ¹	380-500 V	type aR

1) Max. fuses - see national/international regulations for selecting an applicable fuse size.

 Table 4. 3: **Non-UL fuses 200 V to 480 V**
NOTE

If UL/cUL is not to be complied with, we recommend using the following fuses, which will ensure compliance with EN50178:

Frequency Converter	Voltage	Type
P110 - P250	380 - 480 V	type gG
P315 - P450	380 - 480 V	type gR

Table 4. 4: Compliance with EN50178

UL compliance fuses

Frequency converter	Bussmann	Bussmann	Bussmann	SIBA	Littel fuse	Ferraz-Shawmut	Ferraz-Shawmut
200-240 V							
kW	Type RK1	Type J	Type T	Type RK1	Type RK1	Type CC	Type RK1
K25-K37	KTN-R05	JKS-05	JJN-05	5017906-005	KLN-R005	ATM-R05	A2K-05R
K55-1K1	KTN-R10	JKS-10	JJN-10	5017906-010	KLN-R10	ATM-R10	A2K-10R
1K5	KTN-R15	JKS-15	JJN-15	5017906-015	KLN-R15	ATM-R15	A2K-15R
2K2	KTN-R20	JKS-20	JJN-20	5012406-020	KLN-R20	ATM-R20	A2K-20R
3K0	KTN-R25	JKS-25	JJN-25	5012406-025	KLN-R25	ATM-R25	A2K-25R
3K7	KTN-R30	JKS-30	JJN-30	5012406-030	KLN-R30	ATM-R30	A2K-30R
5K5	KTN-R50	JKS-50	JJN-50	5012406-050	KLN-R50	-	A2K-50R
7K5	KTN-R50	JKS-60	JJN-60	5012406-050	KLN-R60	-	A2K-50R
11K	KTN-R60	JKS-60	JJN-60	5014006-063	KLN-R60	A2K-60R	A2K-60R
15K	KTN-R80	JKS-80	JJN-80	5014006-080	KLN-R80	A2K-80R	A2K-80R
18K5	KTN-R125	JKS-150	JJN-125	2028220-125	KLN-R125	A2K-125R	A2K-125R
22K	KTN-R125	JKS-150	JJN-125	2028220-125	KLN-R125	A2K-125R	A2K-125R
30K	FWX-150	-	-	2028220-150	L25S-150	A25X-150	A25X-150
37K	FWX-200	-	-	2028220-200	L25S-200	A25X-200	A25X-200
45K	FWX-250	-	-	2028220-250	L25S-250	A25X-250	A25X-250

 Table 4. 5: **UL fuses, 200 - 240 V**

Frequency converter	Bussmann	Bussmann	Bussmann	SIBA	Littel fuse	Ferraz-Shawmut	Ferraz-Shawmut
380-480 V, 525-600 V							
kW	Type RK1	Type J	Type T	Type RK1	Type RK1	Type CC	Type RK1
K37-1K1	KTS-R6	JKS-6	JJS-6	5017906-006	KLS-R6	ATM-R6	A6K-6R
1K5-2K2	KTS-R10	JKS-10	JJS-10	5017906-010	KLS-R10	ATM-R10	A6K-10R
3K0	KTS-R15	JKS-15	JJS-15	5017906-016	KLS-R16	ATM-R16	A6K-16R
4K0	KTS-R20	JKS-20	JJS-20	5017906-020	KLS-R20	ATM-R20	A6K-20R
5K5	KTS-R25	JKS-25	JJS-25	5017906-025	KLS-R25	ATM-R25	A6K-25R
7K5	KTS-R30	JKS-30	JJS-30	5012406-032	KLS-R30	ATM-R30	A6K-30R
11K	KTS-R40	JKS-40	JJS-40	5014006-040	KLS-R40	-	A6K-40R
15K	KTS-R40	JKS-40	JJS-40	5014006-040	KLS-R40	-	A6K-40R
18K	KTS-R50	JKS-50	JJS-50	5014006-050	KLS-R50	-	A6K-50R
22K	KTS-R60	JKS-60	JJS-60	5014006-063	KLS-R60	-	A6K-60R
30K	KTS-R80	JKS-80	JJS-80	2028220-100	KLS-R80	-	A6K-80R
37K	KTS-R100	JKS-100	JJS-100	2028220-125	KLS-R100		A6K-100R
45K	KTS-R125	JKS-150	JJS-150	2028220-125	KLS-R125		A6K-125R
55K	KTS-R150	JKS-150	JJS-150	2028220-160	KLS-R150		A6K-150R
75K	FWH-220	-	-	2028220-200	L50S-225		A50-P225
90K	FWH-250	-	-	2028220-250	L50S-250		A50-P250

 Table 4. 6: **UL fuses, 380 - 600 V**

Earthing and IT Mains

The mains is connected to the main disconnect switch if this is included.

Check that mains voltage corresponds to the mains voltage of the frequency converter name plate.

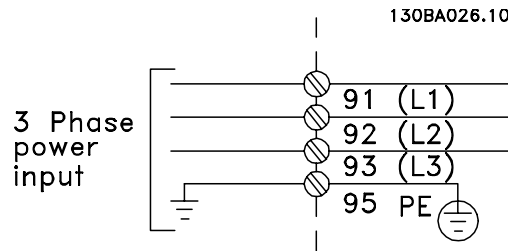

Figure 4. 8: Terminals for mains and earthing.

IT Mains

Do not connect 400 V frequency converters with RFI-filters to mains supplies with a voltage between phase and earth of more than 440 V.

For IT mains and delta earth (grounded leg), mains voltage may exceed 440 V between phase and earth.

Failure to follow recommendations could result in death or serious injury.

Mains Wiring Overview













Enclosure:	A2 (IP 20/IP 21)	A3 (IP 20/IP 21)	A4 (IP 55/IP 66)	A5 (IP 55/IP 66)	B1 (IP 21/IP 55/ IP 66)	B2 (IP 21/IP 55/ IP 66)
	 130BA340.10	 130BA341.10	 130BA342.10	 130BA342.10	 130BA343.10	 130BA344.10
Motor size:						
200-240 V	1.1-3.0 kW	3.7 kW	1.1-2.2 kW	1.1-3.7 kW	5.5-11 kW	15 kW
380-480 V	1.1-4.0 kW	5.5-7.5 kW	1.1-4.0 kW	1.1-7.5 kW	11-18.5 kW	22-30 kW
525-600 V		1.1-7.5 kW		1.1-7.5 kW	11-18.5 kW	22-30 kW
Goto:	4.1.5		4.1.6	4.1.6	4.1.7	
Enclosure:	B3 (IP 20)	B4 (IP 20)	C1 (IP 21/IP 55/66)	C2 (IP 21/IP 55/66)	C3 (IP 20)	C4 (IP20)
	 130BA768.10	 130BA344.10	 130BA344.10	 130BA344.10	 130BA344.10	 130BA344.10
Motor size:						
200-240 V	5.5-11 kW	15-18.5 kW	18.5-30 kW	37-45 kW	22-30 kW	37-45 kW
380-480 V	11-18.5 kW	22-37 kW	37-55 kW	75-90 kW	45-55 kW	75-90 kW
525-600 V	11-18.5 kW	22-37 kW	37-55 kW	75-90 kW	45-55 kW	75-90 kW
Goto:			4.1.8		4.1.9	

Table 4. 7: Mains wiring table.

Mains Connection for A2 and A3

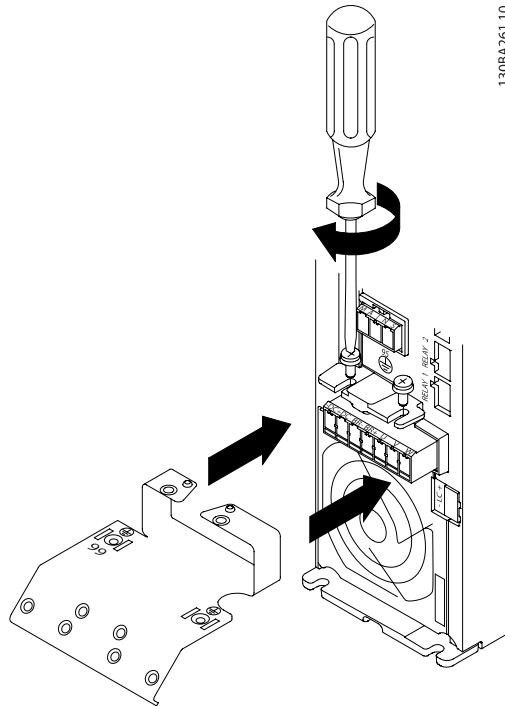

1308A261.10

Figure 4.9: First mount the two screws on the mounting plate, slide it into place and tighten fully.

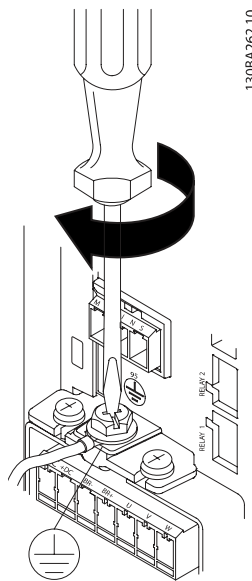

1308A262.10

Figure 4.10: When mounting cables, first mount and tighten earth cable.

The earth connection cable cross section must be at least 10 mm² or 2 rated mains wires terminated separately according to *EN 50178/IEC 61800-5-1*.

Failure to comply can result in high voltages on the chassis, which could result in death or serious injury, due to electrocution.

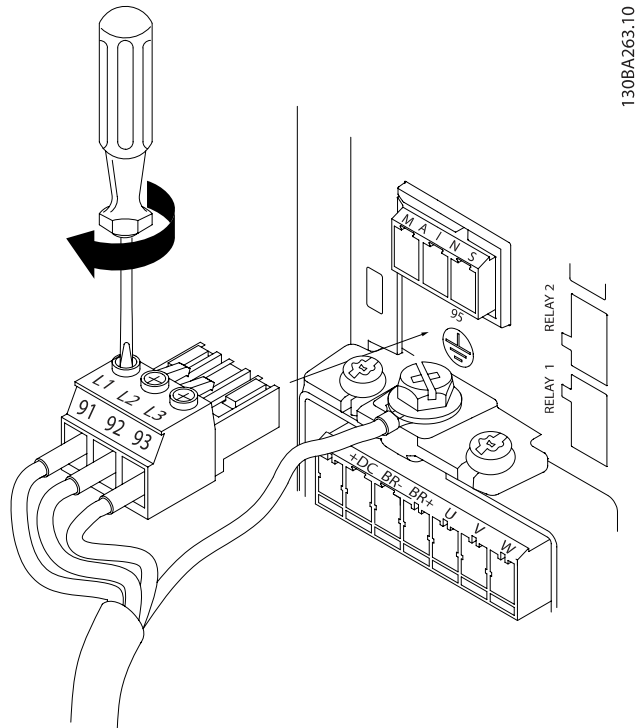

Figure 4. 11: Then mount mains plug and tighten wires.

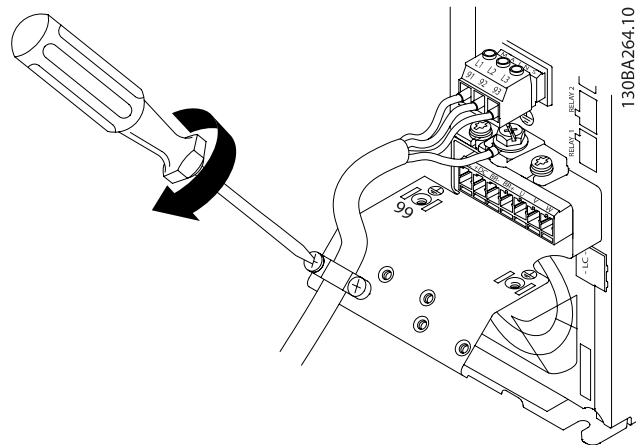

Figure 4. 12: Finally tighten support bracket on mains wires.

Mains Connection for A4/A5

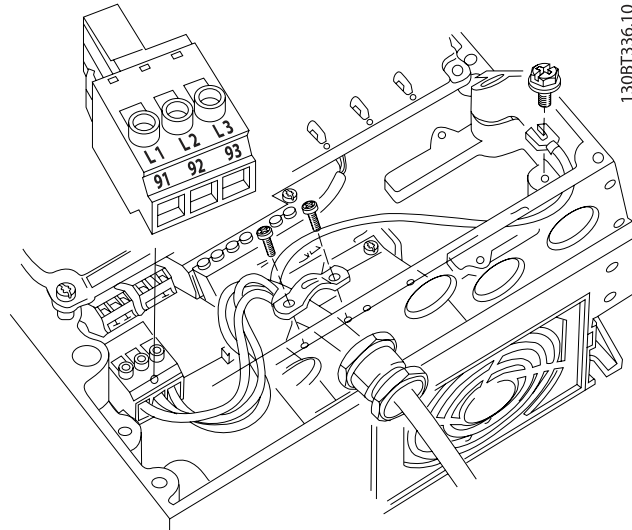

Figure 4. 13: How to connect to mains and earthing without mains disconnect switch. Note that a cable clamp is used.

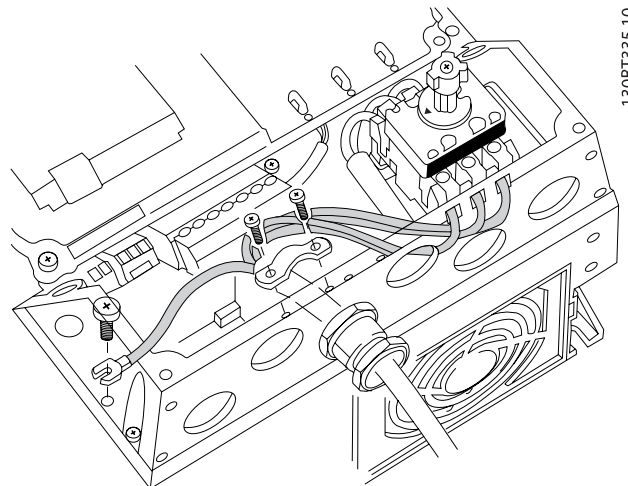

Figure 4. 14: How to connect to mains and earthing with mains disconnect switch.

Mains Connection for B1, B2 and B3

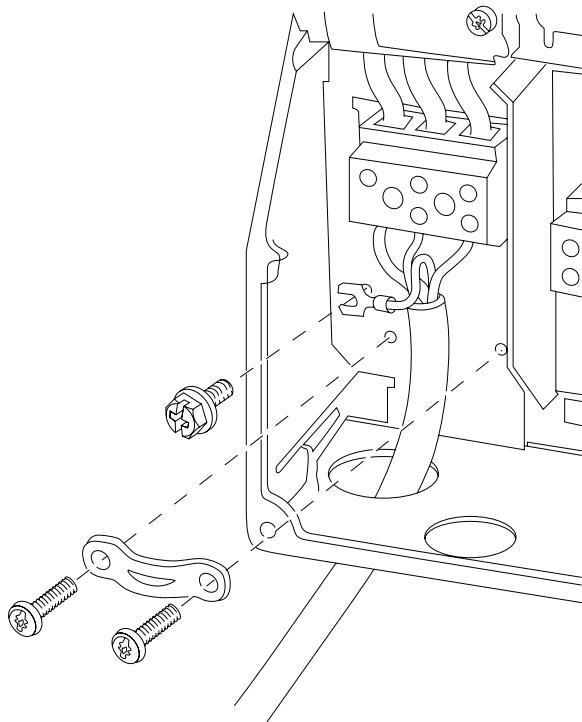

Figure 4.15: How to connect to mains and earthing for B1 and B2

130BT332.10

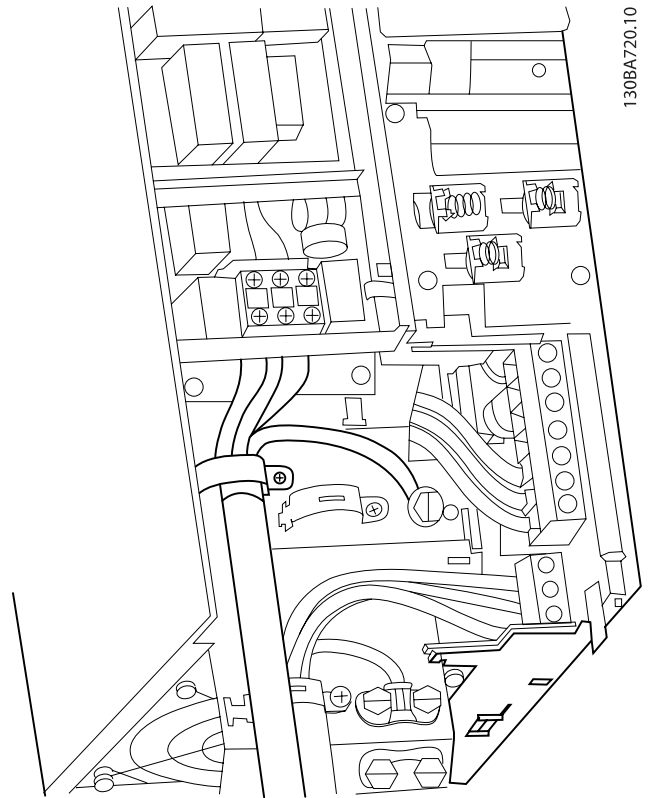

Figure 4.17: How to connect to mains and earthing for B3 with RFI.

130BA720.10

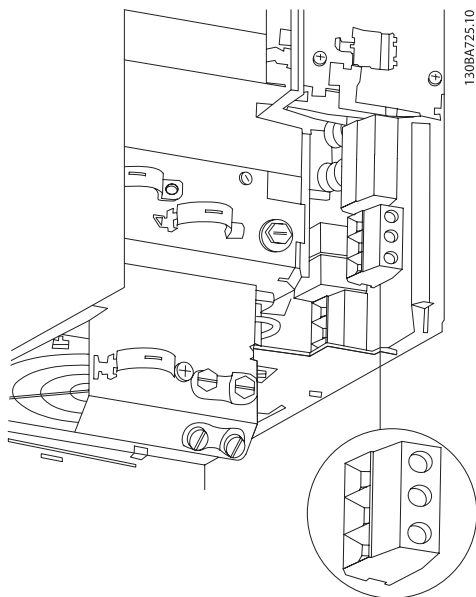

Figure 4.16: How to connect to mains and earthing for B3 without RFI.

130BA725.10

NOTE: For correct cable dimensions please see the section *General Specifications* at the back of this manual.

Mains Connection for B4, C1 and C2

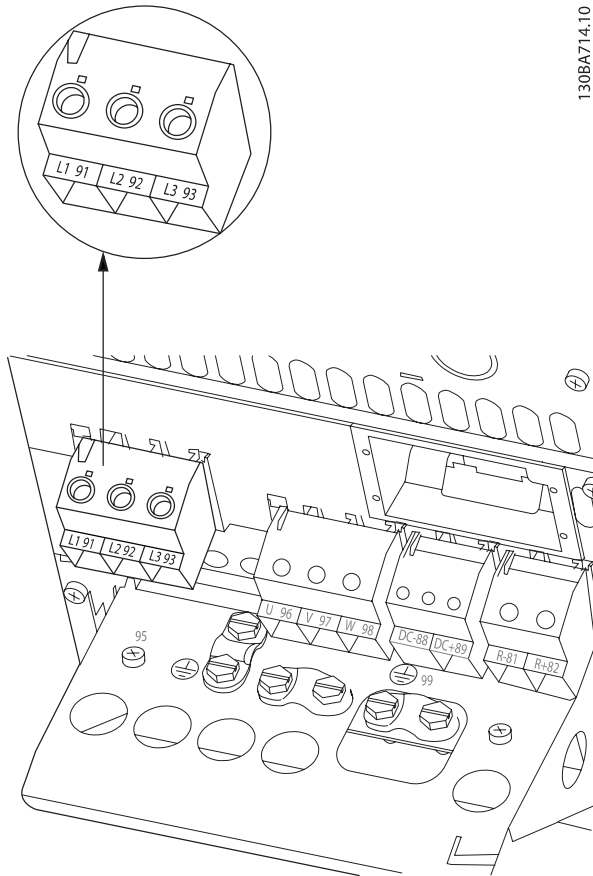

Figure 4.18: How to connect to mains and earthing for B4.

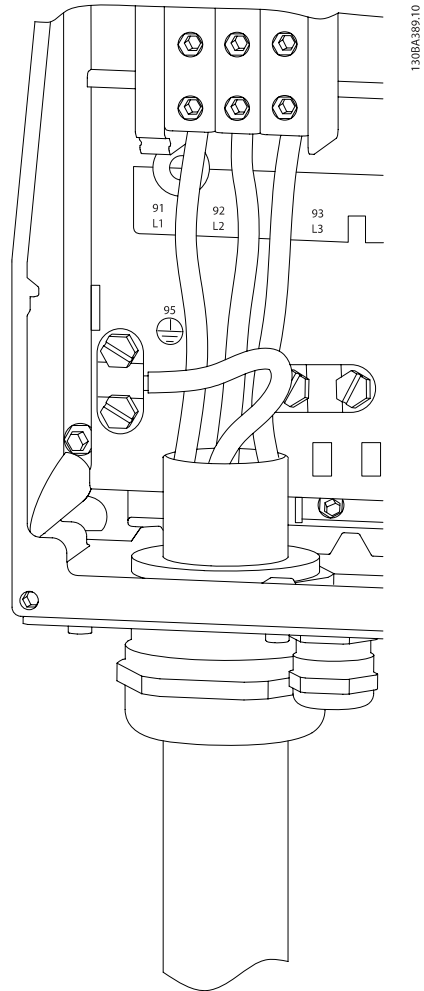
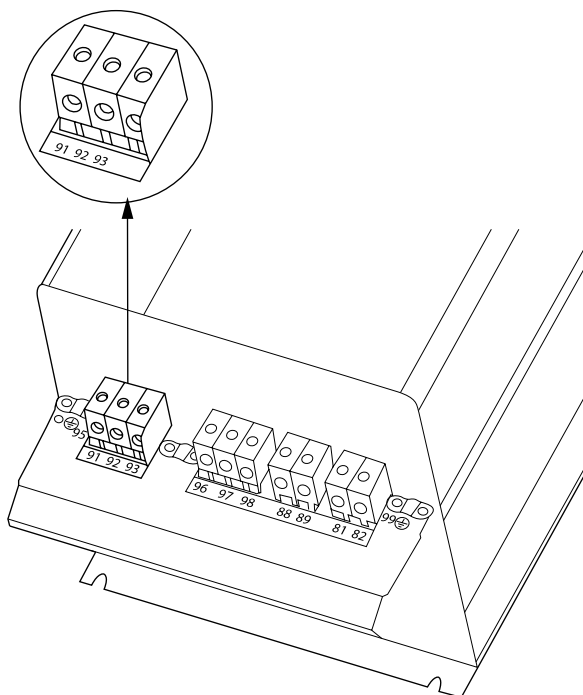

Figure 4.19: How to connect to mains and earthing for C1 and C2.

Mains Connection for C3 and C4



130BA718.10

Figure 4. 20: How to connect C3 to mains and earthing.

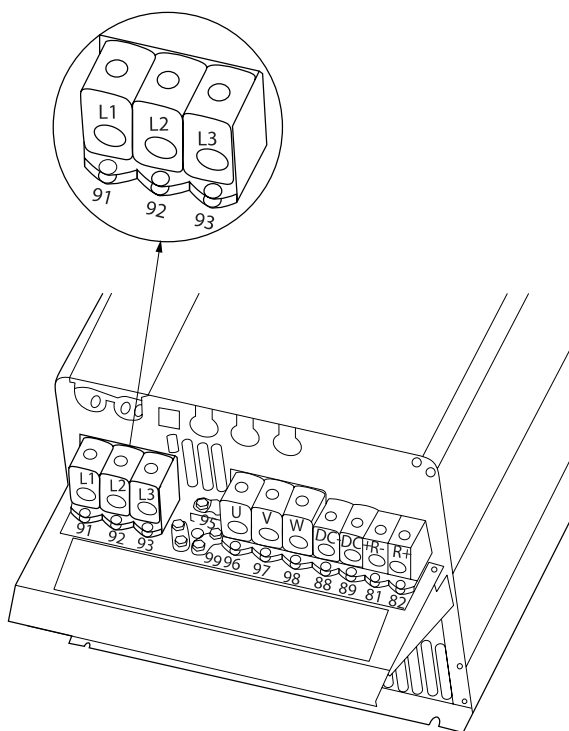

130BA719.10

Figure 4. 21: How to connect C4 to mains and earthing.

How to Connect Motor - Introduction

See section *General Specifications* for correct dimensioning of motor cable cross-section and length.

- Use a screened/armoured motor cable to comply with EMC emission specifications (or install the cable in metal conduit).
- Keep the motor cable as short as possible to reduce the noise level and leakage currents.
- Connect the motor cable screen/armour to both the decoupling plate of the frequency converter and to the metal of the motor. (Same applies to both ends of metal conduit if used instead of screen.)
- Make the screen connections with the largest possible surface area (cable clamp or by using an EMC cable gland). This is done by using the supplied installation devices in the frequency converter.
- Avoid terminating the screen by twisting the ends (pigtails), as this will spoil high frequency screening effects.
- If it is necessary to break the continuity of the screen to install a motor isolator or motor relay, the continuity must be maintained with the lowest possible HF impedance.

Cable length and cross-section

The frequency converter has been tested with a given length of cable and a given cross-section of that cable. If the cross-section is increased, the cable capacitance - and thus the leakage current - may increase, and the cable length must be reduced correspondingly.

Switching frequency

When frequency converters are used together with sine wave filters to reduce the acoustic noise from a motor, the switching frequency must be set according to the sine wave filter instruction in par. 14-01 [Switching Frequency](#).

Precautions while using Aluminium conductors

Aluminium conductors are not recommended for cable cross sections below 35 mm². Terminals can accept aluminium conductors but the conductor surface has to be clean and the oxidation must be removed and sealed by neutral acid free Vaseline grease before the conductor is connected.

Furthermore, the terminal screw must be retightened after two days due to the softness of the aluminium. It is crucial to ensure the connection makes a gas tight joint, otherwise the aluminium surface will oxidize again.

All types of three-phase asynchronous standard motors can be connected to the frequency converter. Normally, small motors are star-connected (230/400 V, D/Y). Large motors are delta-connected (400/690 V, D/Y). Refer to the motor name plate for correct connection mode and voltage.

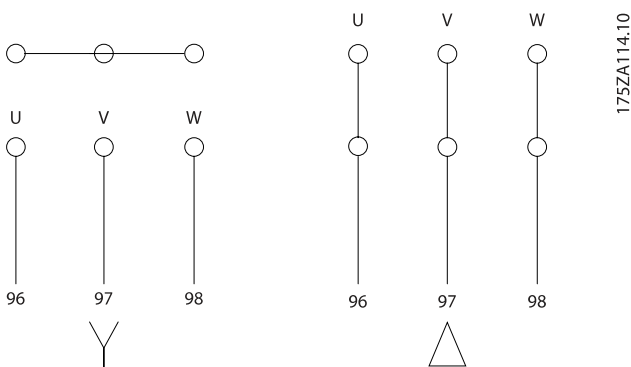

Figure 4. 22: Terminals for motor connection

⚠ WARNING

In motors without phase insulation paper or other insulation reinforcement suitable for operation with voltage supply (such as a frequency converter), fit a sine-wave filter on the output of the frequency converter. (Motors that comply with IEC 60034-17 do not require a Sine-wave filter) failure to do so could result in equipment damage.

No.	96	97	98	Motor voltage 0-100% of mains voltage.
	U	V	W	3 cables out of motor
	U1 W2	V1 U2	W1 V2	6 cables out of motor, Delta-connected
	U1	V1	W1	6 cables out of motor, Star-connected U2, V2, W2 to be interconnected separately (optional terminal block)
No.	99			Earth connection
	PE			

Table 4. 8: 3 and 6 cable motor connection.

Motor Wiring Overview













Enclosure:	A2 (IP 20/IP 21)	A3 (IP 20/IP 21)	A4 (IP 55/IP 66)	A5 (IP 55/IP 66)	B1 (IP 21/IP 55/ IP 66)	B2 (IP 21/IP 55/ IP 66)
	 130BA340.10	 130BA341.10	 130BA342.10	 130BA342.10	 130BA343.10	 130BA344.10
Motor size:						
200-240 V	1.1-3.0 kW	3.7 kW	1.1-2.2 kW	1.1-3.7 kW	5.5-11 kW	15 kW
380-480 V	1.1-4.0 kW	5.5-7.5 kW	1.1-4 kW	1.1-7.5 kW	11-18.5 kW	22-30 kW
				1.1-7.5 kW	11-18.5 kW	22-30 kW
Goto:	4.1.12		4.1.13	4.1.13	4.1.14	
Enclosure:	B3 (IP 20)	B4 (IP 20)	C1 (IP 21/IP 55/66)	C2 (IP 21/IP 55/66)	C3 (IP 20)	C4 (IP 20)
	 130BA344.10	 130BA344.10	 130BA344.10	 130BA344.10	 130BA344.10	 130BA344.10
Motor size:						
200-240 V	5.5-11 kW	15-18.5 kW	18.5-30 kW	37-45 kW	22-30 kW	37-45 kW
380-480 V	11-18.5 kW	22-37 kW	37-55 kW	75-90 kW	45-55 kW	75-90 kW
	11-18.5 kW	22-37 kW	37-55 kW	75-90 kW	45-55 kW	75-90 kW
Goto:	4.1.15		4.1.16		4.1.17	

Table 4. 9: Motor wiring table.

Motor Connection for A2 and A3

Follow these drawings step by step for connecting the motor to the frequency converter.

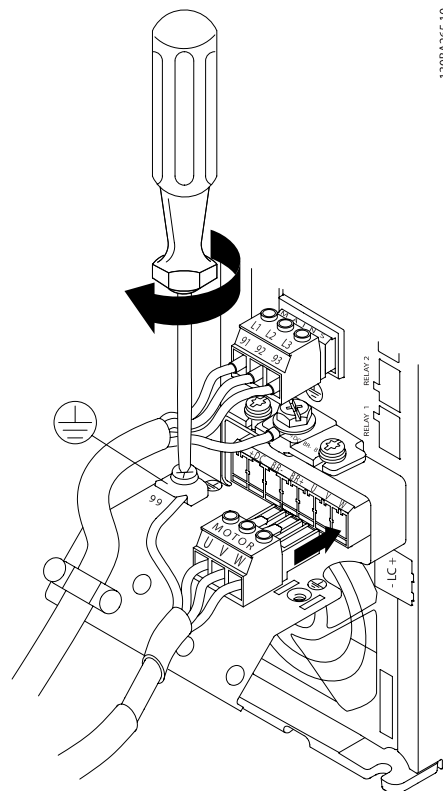

Figure 4. 23: First terminate the motor earth, then place motor U, V and W wires in plug and tighten.

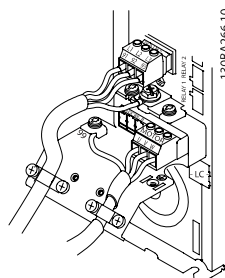

Figure 4. 24: Mount cable clamp to ensure 360 degree connection between chassis and screen, note the outer insulation of the motor cable is removed under the clamp.

Motor Connection for A4/A5

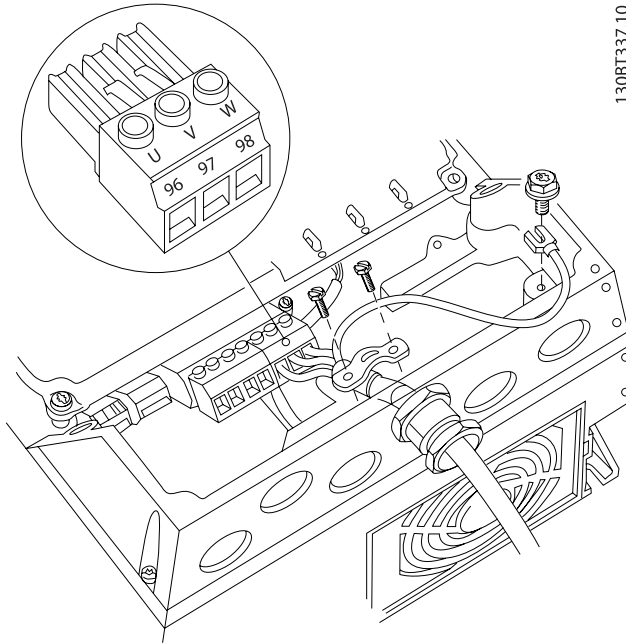
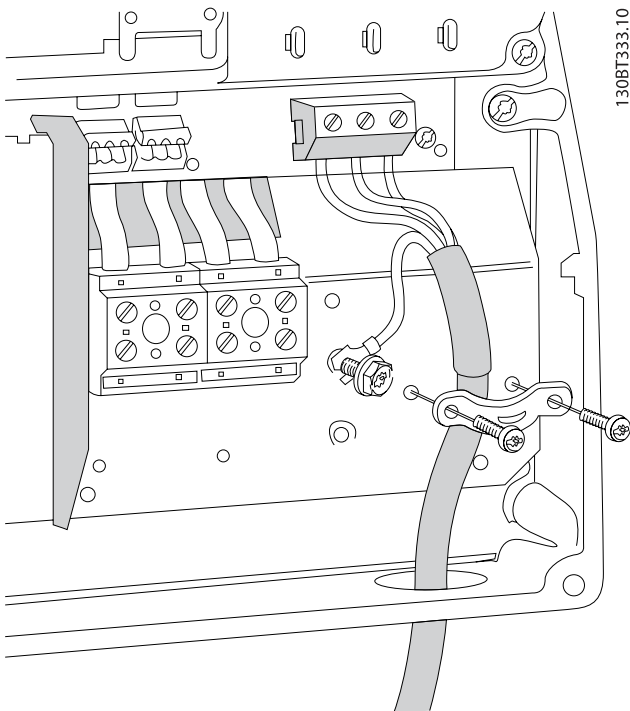

Figure 4. 25: First terminate the motor earth, then place motor U, V and W wires in terminal and tighten. Please ensure that the outer insulation of the motor cable is removed under the EMC clamp.

Motor Connection for B1 and B2



First terminate the motor earth, then Place motor U, V and W wires in terminal and tighten. Please ensure that the outer insulation of the motor cable is removed under the EMC clamp.

Motor Connection for B3 and B4

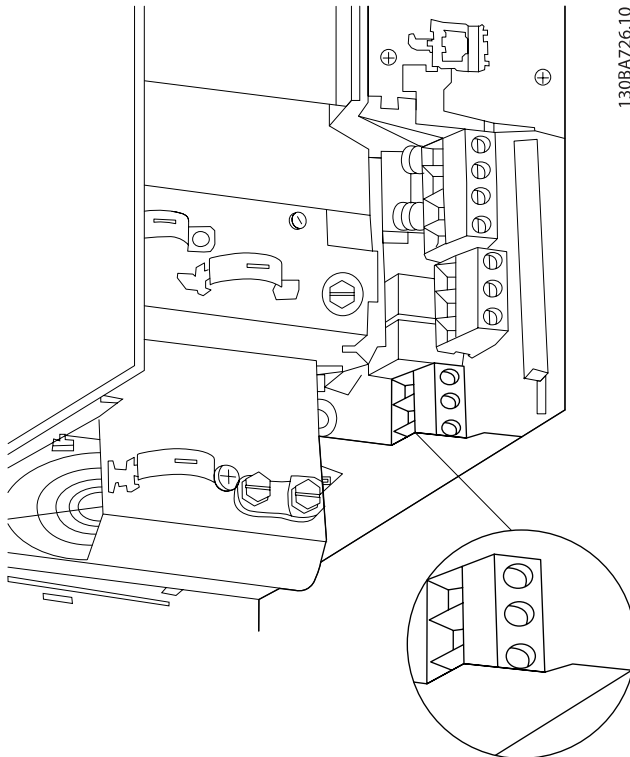

Figure 4. 26: First terminate the motor earth, then Place motor U, V and W wires in terminal and tighten. Please ensure that the outer insulation of the motor cable is removed under the EMC clamp.

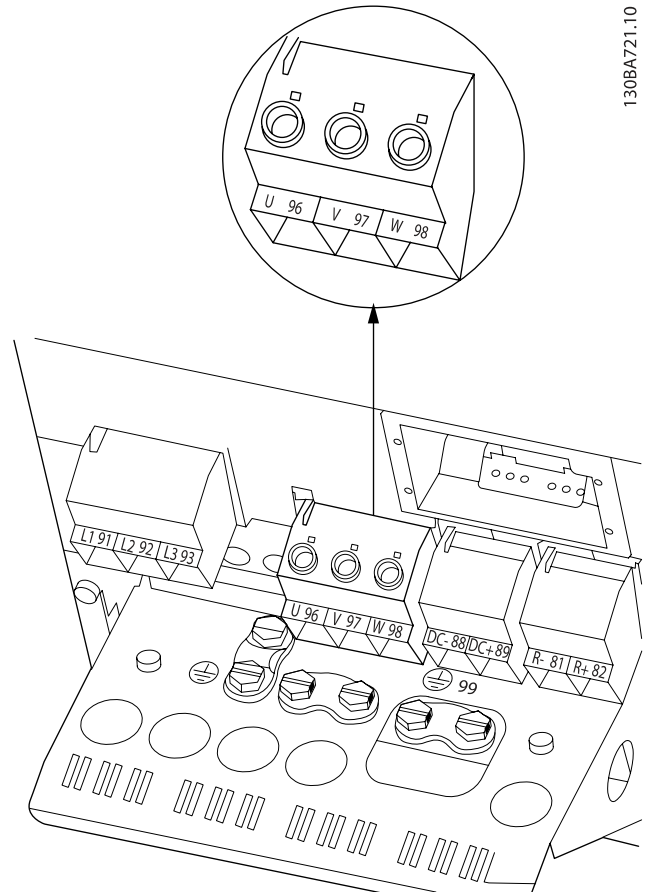
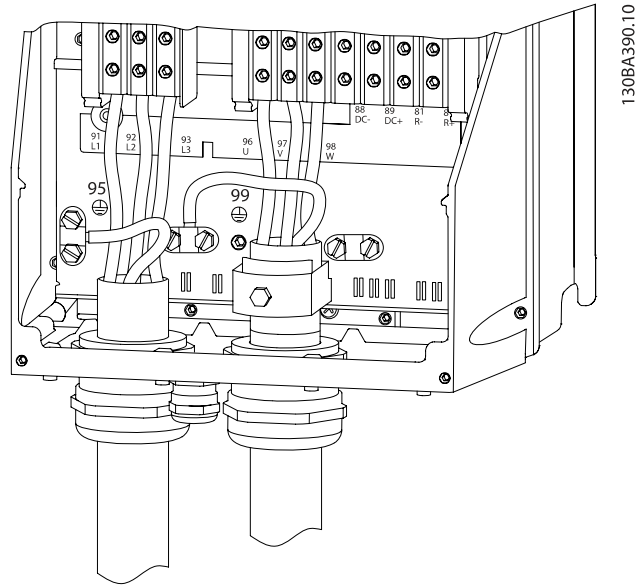

Figure 4. 27: First terminate the motor earth, then Place motor U, V and W wires in terminal and tighten. Please ensure that the outer insulation of the motor cable is removed under the EMC clamp.

Motor Connection for C1 and C2



First terminate the motor earth, then Place motor U, V and W wires in terminal and tighten. Please ensure that the outer insulation of the motor cable is removed under the EMC clamp.

Motor Connection for C3 and C4

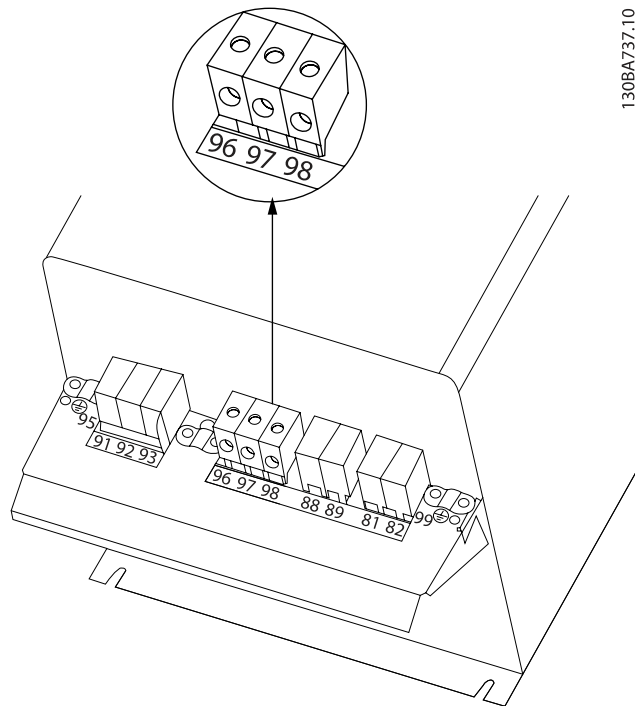

First terminate the motor earth, then place motor U, V and W wires into the appropriate terminals and tighten. Please ensure that the outer insulation of the motor cable is removed under the EMC clamp.

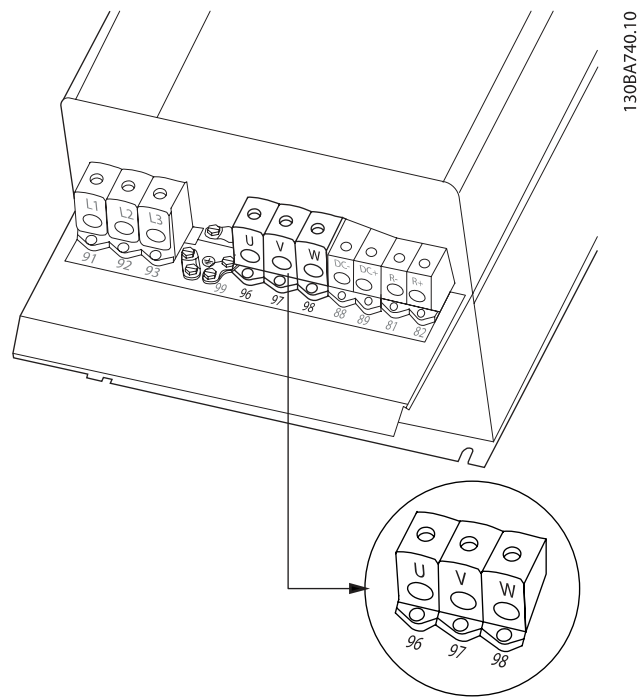

First terminate the motor earth, then place motor U, V and W wires into the appropriate terminals and tighten. Please ensure that the outer insulation of the motor cable is removed under the EMC clamp.

Motor Wiring Overview













Enclosure:	A2 (IP 20/IP 21)	A3 (IP 20/IP 21)	A4 (IP 55/IP 66)	A5 (IP 55/IP 66)	B1 (IP 21/IP 55/ IP 66)	B2 (IP 21/IP 55/ IP 66)
	 130BA340.10	 130BA341.10	 130BA342.10	 130BA342.10	 130BA343.10	 130BA344.10
Motor size:						
200-240 V	1.1-3.0 kW	3.7 kW	1.1-2.2 kW	1.1-3.7 kW	5.5-11 kW	15 kW
380-480 V	1.1-4.0 kW	5.5-7.5 kW	1.1-4 kW	1.1-7.5 kW	11-18.5 kW	22-30 kW
				1.1-7.5 kW	11-18.5 kW	22-30 kW
Goto:	4.1.12		4.1.13	4.1.13	4.1.14	
Enclosure:	B3 (IP 20)	B4 (IP 20)	C1 (IP 21/IP 55/66)	C2 (IP 21/IP 55/66)	C3 (IP 20)	C4 (IP 20)
	 130BA344.10	 130BA344.10	 130BA344.10	 130BA344.10	 130BA344.10	 130BA344.10
Motor size:						
200-240 V	5.5-11 kW	15-18.5 kW	18.5-30 kW	37-45 kW	22-30 kW	37-45 kW
380-480 V	11-18.5 kW	22-37 kW	37-55 kW	75-90 kW	45-55 kW	75-90 kW
	11-18.5 kW	22-37 kW	37-55 kW	75-90 kW	45-55 kW	75-90 kW
Goto:	4.1.15		4.1.16		4.1.17	

Table 4. 10: Motor wiring table.

Wiring Example and Testing

The following section describes how to terminate control wires and how to access them. For an explanation of the function, programming and wiring of the control terminals, please see chapter, *How to program the frequency converter*.

DC Bus Connection

The DC bus terminal is used for DC back-up, with the intermediate circuit being supplied from an external source.

Terminal number 88 and 89 are used.

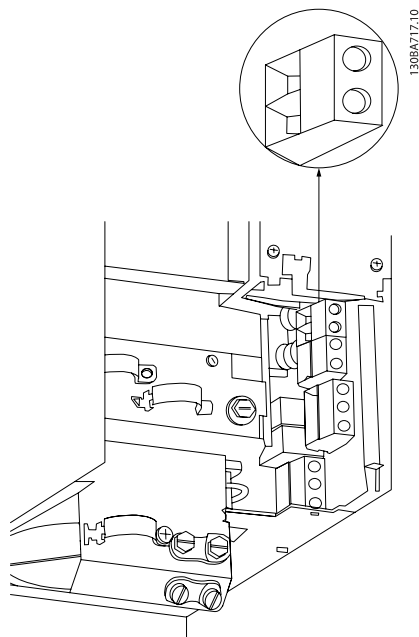

Figure 4.28: DC bus connections for enclosure B3.

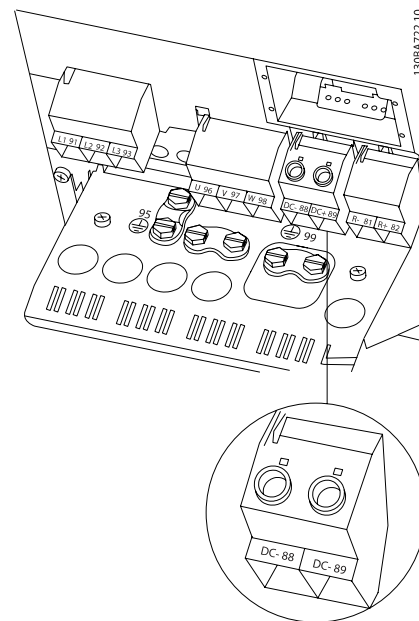

Figure 4.29: DC bus connections for enclosure B4.

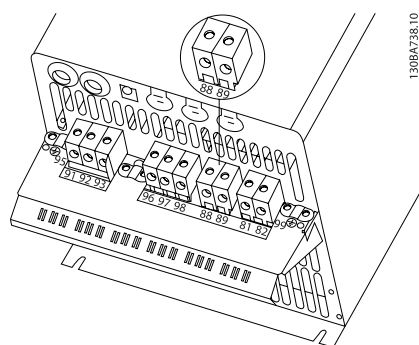

Figure 4.30: DC bus connections for enclosure C3.

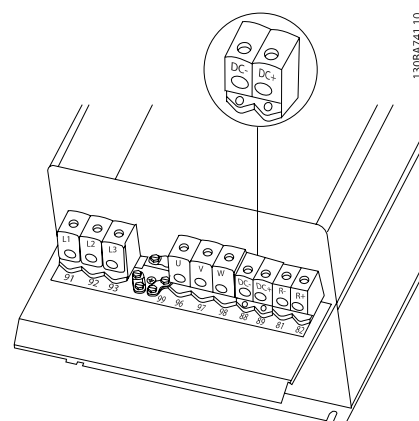

Figure 4.31: DC bus connections for enclosure C4.

Please contact Trane if you require further information.

Relay Connection

To set relay output, see par. group 5-4* Relays.

No.	01 - 02	make (normally open)
	01 - 03	break (normally closed)
	04 - 05	make (normally open)
	04 - 06	break (normally closed)

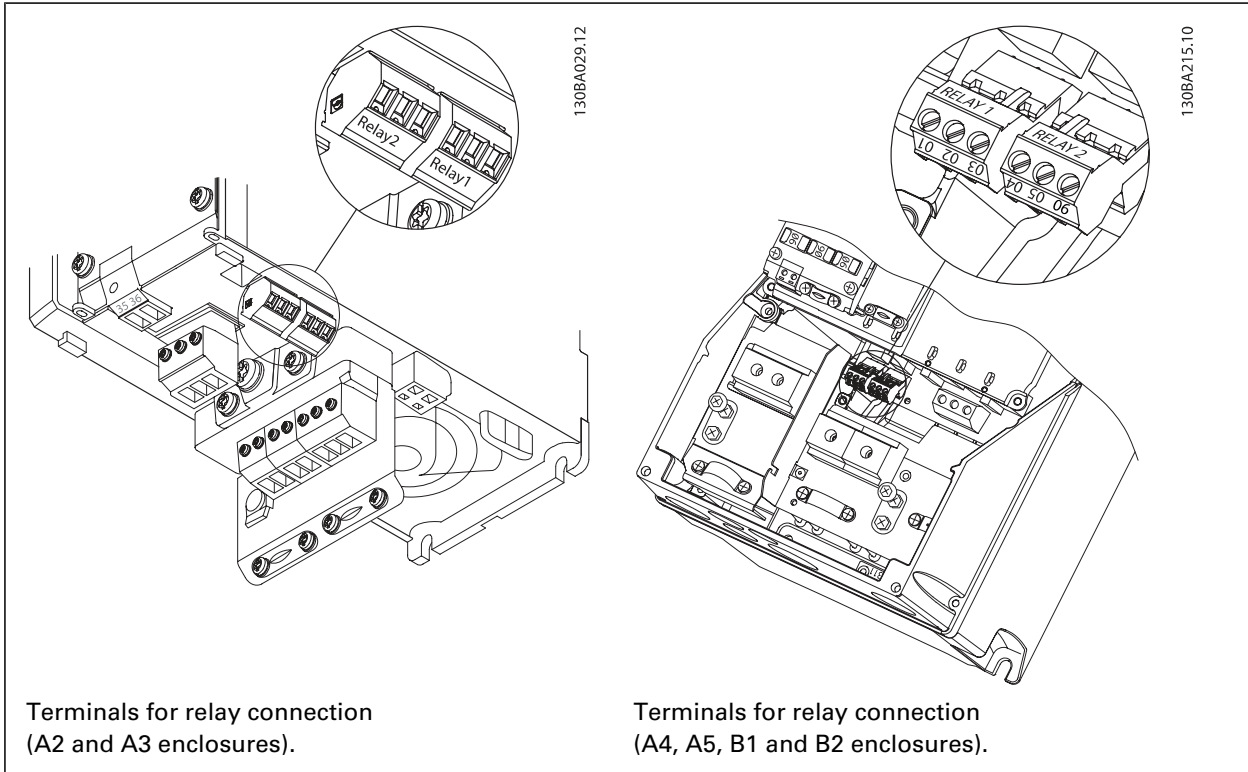

Terminals for relay connection (A2 and A3 enclosures).

Terminals for relay connection (A4, A5, B1 and B2 enclosures).

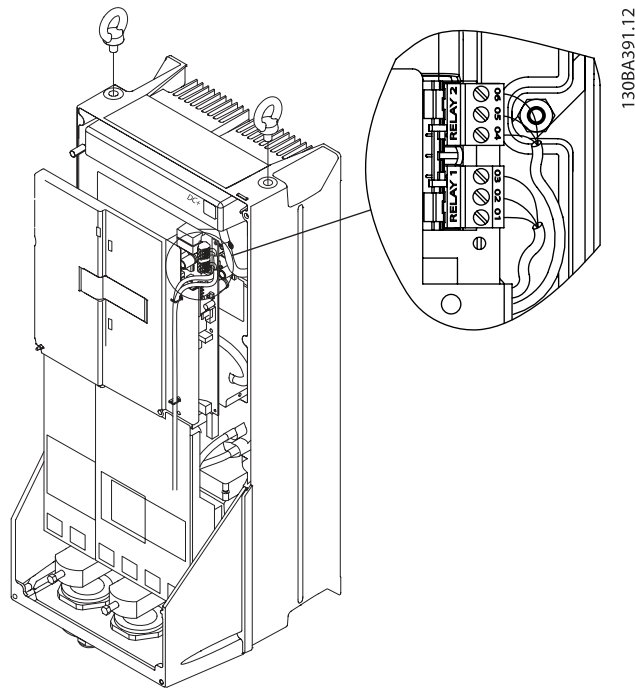

Figure 4. 36: Terminals for relay connection (C1 and C2 enclosures).

The relay connections are shown in the cut-out with relay plugs (from the Accessory Bag) fitted.

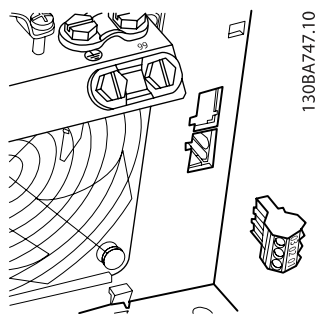

Figure 4. 37: Terminals for relay connections for B3. Only one relay input is fitted from the factory. When the second relay is needed remove knock-out.

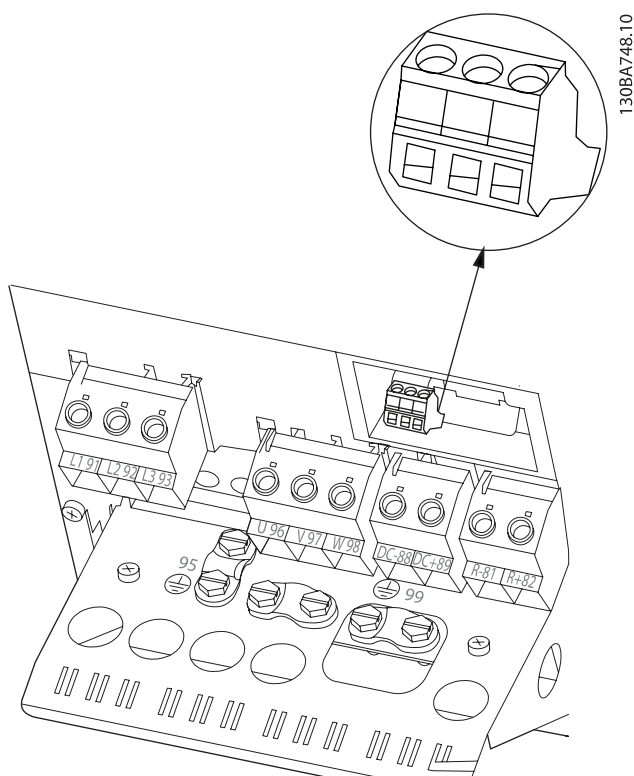

Figure 4. 38: Terminals for relay connections for B4.

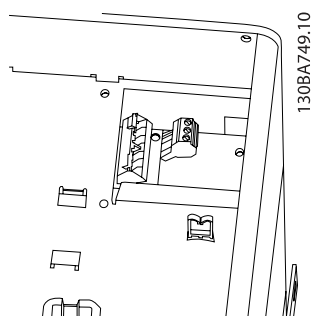

Figure 4. 39: Terminals for relay connections for C3 and C4. Located in the upper right corner of the frequency converter.

Relay Output

Relay 1

- Terminal 01: common
- Terminal 02: normal open 240 V AC
- Terminal 03: normal closed 240 V AC

Relay 2

- Terminal 04: common
- Terminal 05: normal open 400 V AC
- Terminal 06: normal closed 240 V AC

Relay 1 and relay 2 are programmed in par. 5-40 [Function Relay](#), par. 5-41 [On Delay, Relay](#), and par. 5-42 [Off Delay, Relay](#).

Additional relay outputs by using option module MCB 105.

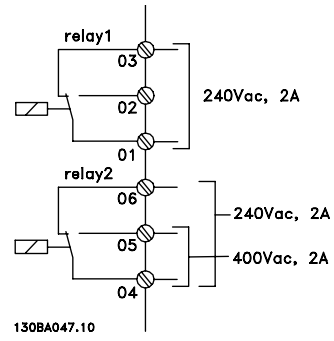

Access to Control Terminals

WARNING

Hazardous Voltage!

Disconnect all electric power, including remote disconnects before servicing. Follow proper lockout/tagout procedures to ensure the power can not be inadvertently energized. Failure to disconnect power before servicing could result in death or serious injury.

All terminals to the control cables are located underneath the terminal cover on the front of the frequency converter. Remove the terminal cover with a screwdriver.

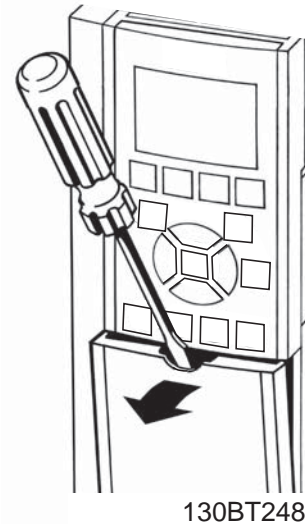

Figure 4. 40: Access to control terminals for A2, A3, B3, B4, C3 and C4 enclosures

Remove front-cover to access control terminals. When replacing the front-cover, please ensure proper fastening by applying a torque of 2 Nm.

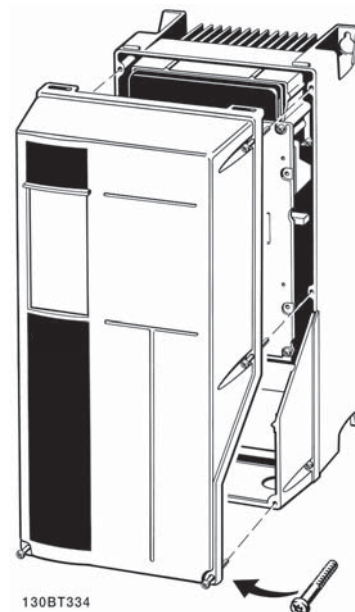

Figure 4. 41: Access to control terminals for A4, A5, B1, B2, C1 and C2 enclosures

Control Terminals

Drawing reference numbers:

1. 10-pole plug digital I/O.
2. 3-pole plug RS-485 Bus.
3. 6-pole analog I/O.
4. USB connection.

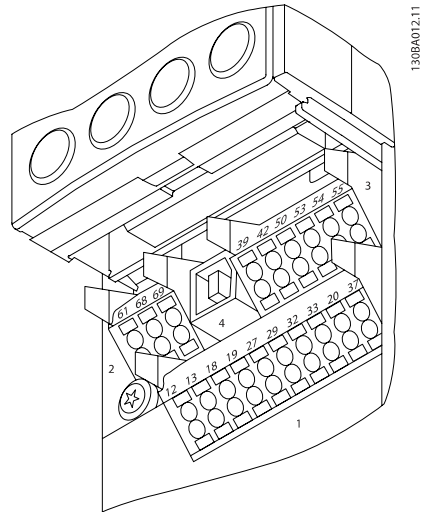

Figure 4.42: Control terminals (all enclosures)

How to Test Motor and Direction of Rotation

WARNING

Unintended motor start could occur. Follow proper lockout/tagout procedures to ensure the power cannot be inadvertently energized. Stay away from rotating components to avoid being injured. Failure to follow recommendations could result in death or serious injury.

Please follow these steps to test the motor connection and direction of rotation. Start with no power to the unit.

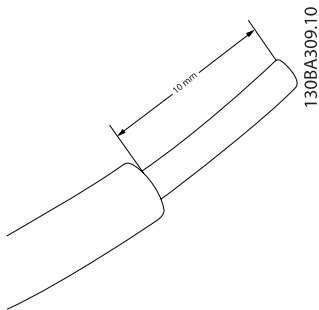

Figure 4.43:

Step 1: First remove the insulation on both ends of a 50 to 70 mm piece of wire.

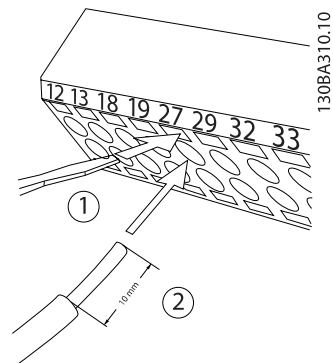

Figure 4.44:

Step 2: Insert one end in terminal 27 using a suitable terminal screwdriver.

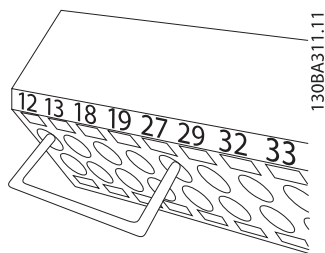

Figure 4.45:
Step 3: Insert the other end in terminal 12 or 13.

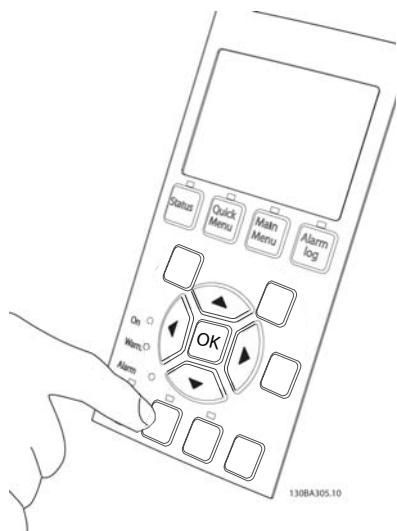

Figure 4.46:
Step 4: Power-up the unit and press the [Off] button. In this state the motor should not rotate. Press [Off] to stop the motor at any time. Note the LED at the [OFF] button should be lit. If alarms or warnings are flashing, please see chapter 7 regarding these.



Figure 4.47:
Step 5: By pressing the [Hand on] button, the LED above the button should be lit and the motor may rotate.

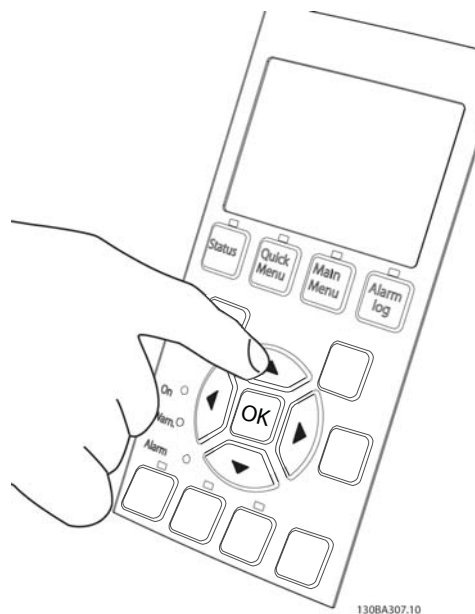

Figure 4.48:
Step 6: The speed of the motor can be seen in the keypad. It can be adjusted by pushing the up ▲ and down ▼ arrow buttons.

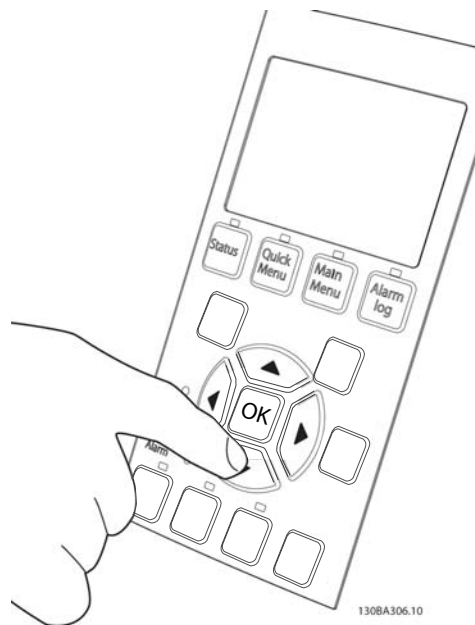

Figure 4.49:
Step 7: To move the cursor, use the left ◀ and right ▶ arrow buttons. This enables changing the speed in larger increments.

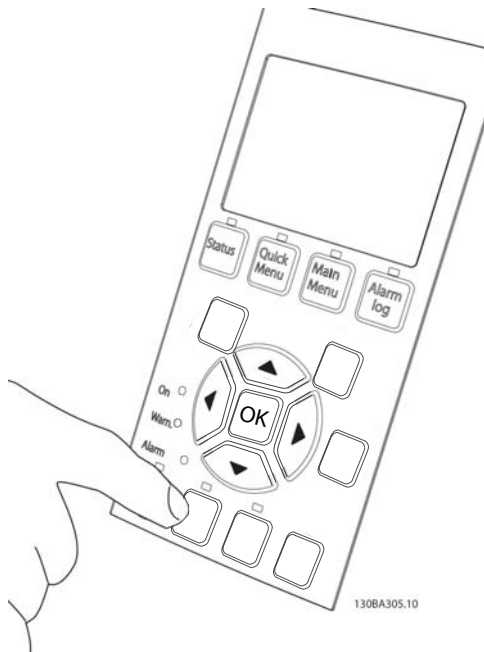

Figure 4. 50: **Step 8:** Press the [Off] button to stop the motor again.

Hazardous Voltage!

Disconnect all electric power, including remote disconnects before servicing. Follow proper lockout/tagout procedures to ensure the power can not be inadvertently energized. Failure to disconnect power before servicing could result in death or serious injury.

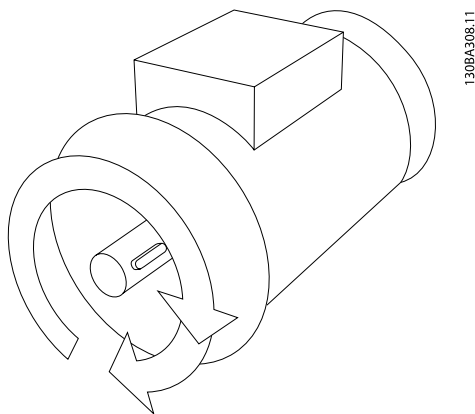

Figure 4. 51:
Step 9: Change two motor wires if the desired rotation of direction is not achieved.

Switches S201, S202, and S801

Switches S201 (AI 53) and S202 (AI 54) are used to select a current (0-20 mA) or a voltage (0 to 10 V) configuration of the analog input terminals 53 and 54 respectively.

Switch S801 (BUS TER.) can be used to enable termination on the RS-485 port (terminals 68 and 69).

Please note that the switches may be covered by an option, if fitted.

Default setting:

S201 (AI 53) = OFF (voltage input)

S202 (AI 54) = OFF (voltage input)

S801 (Bus termination) = OFF

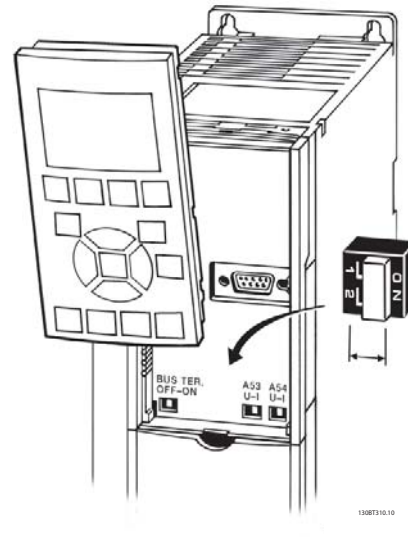

Figure 4. 52: Switches location.

Final Optimization and Test

To optimize motor shaft performance and optimize the frequency converter for the connected motor and installation, please follow these steps. Ensure that frequency converter and motor are connected and that power is applied to frequency converter.

Before power up ensure that connected equipment is ready for use.

Step 1: Locate motor name plate

The motor is either star- (Y) or delta- connected (Δ). This information is located on the motor name plate data.

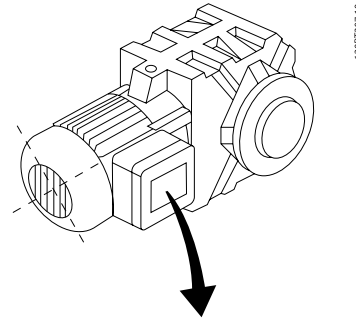

13081307.10

BAUER D-7 3734 ESUNGEN				
3-- MOTOR NR. 1827421 2003				
S/E005A9				
	1,5	KW		
n _s	31,5	/MIN.	400	Y V
n	1400	/MIN.	50	Hz
cos	0,80		3,6	A
1,7L				
B	IP 65	H1/1A		

Figure 4. 53: Motor name plate example

Step 2: Enter motor name plate data in following parameter list

To access list first press [QUICK MENU] key then select "Q2 Quick Setup".

1.	Par. 1-20 Motor Power [kW] Par. 1-21 Motor Power [HP]
2.	Par. 1-22 Motor Voltage
3.	Par. 1-23 Motor Frequency
4.	Par. 1-24 Motor Current
5.	Par. 1-25 Motor Nominal Speed

Table 4. 11: Motor related parameters

Step 3: Activate Automatic Motor Adaptation (AMA) Activate Auto Tune

Performing AMA ensures best possible performance. AMA automatically takes measurements from the specific motor connected and compensates for installation variances.

1. Connect terminal 27 to terminal 12 or use [QUICK MENU] and "Q2 Quick Setup" and set Terminal 27 par. 5-12 [Terminal 27 Digital Input](#) to *No function [0]*
2. Press [QUICK MENU], select "Q3 Function Setups", select "Q3-1 General Settings", select "Q3-10 Adv. Motor Settings" and scroll down to par. 1-29 [Automatic Motor Adaptation \(AMA\)](#) Automatic Motor Adaption.
3. Press [OK] to activate the AMA par. 1-29 [Automatic Motor Adaptation \(AMA\)](#).
4. Choose between complete or reduced AMA. If sine wave filter is mounted, run only reduced AMA, or remove sine wave filter during AMA procedure.
5. Press [OK] key. Display should show "Press [Hand on] to start".
6. Press [Hand on] key. A progress bar indicates if AMA is in progress.

Stop the AMA during operation

1. Press the [OFF] key - the frequency converter enters into alarm mode and the display shows that the AMA was terminated by the user.

Successful AMA

1. The display shows "Press [OK] to finish AMA".
2. Press the [OK] key to exit the AMA state.

Unsuccessful AMA

1. The frequency converter enters into alarm mode. A description of the alarm can be found in the *Troubleshooting* section.
2. "Report Value" in the [Alarm Log] shows the last measuring sequence carried out by the AMA, before the frequency converter entered alarm mode. This number along with the description of the alarm will assist troubleshooting. If contacting Trane Service, make sure to mention number and alarm description.

Unsuccessful AMA is often caused by incorrectly entered motor name plate data or too big difference between the motor power size and the frequency converter power size.

Step 4: Set speed limit and ramp time

Set up the desired limits for speed and ramp time.

Par. 3-02 Minimum Reference
Par. 3-03 Maximum Reference

Par. 4-11 Motor Speed Low Limit [RPM] or par. 4-12 Motor Speed Low Limit [Hz]
Par. 4-13 Motor Speed High Limit [RPM] or par. 4-14 Motor Speed High Limit [Hz]

Par. 3-41 Ramp 1 Ramp-up Time Ramp-up Time 1 [s]
Par. 3-42 Ramp 1 Ramp-down Time Ramp-down Time 1 [s]

See the section *How to program the frequency converter, Quick Menu Mode* for an easy set-up of these parameters.

How to Operate the Frequency Converter

Two Ways of Operating

The frequency converter can be operated in two ways:

1. Graphical keypad, see 5.1.2
2. RS-485 serial communication or USB, both for PC connection, see 5.1.4

If the frequency converter is fitted with fieldbus option, please refer to relevant documentation.

How to operate graphical keypad

The keypad is divided into four functional groups:

1. Graphical display with Status lines.
2. Menu keys and indicator lights (LED's) - selecting mode, changing parameters and switching between display functions.
3. Navigation keys and indicator lights (LEDs).
4. Operation keys and indicator lights (LEDs).

Graphical display:

The LCD-display is back-lit with a total of 6 alpha-numeric lines. All data is displayed on the keypad which can show up to five operating variables while in [Status] mode.

Display lines:

- a. **Status line:** Status messages displaying icons and graphics.
- b. **Line 1-2:** Operator data lines displaying data and variables defined or chosen by the user. By pressing the [Status] key, up to one extra line can be added.
- c. **Status line:** Status messages displaying text.

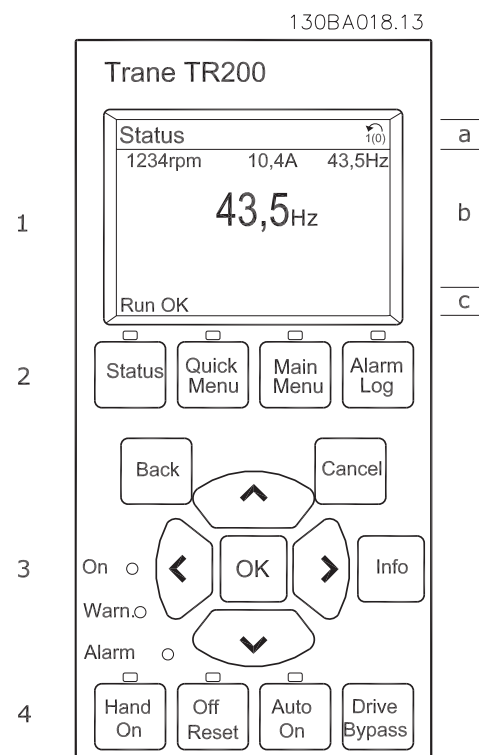

The display is divided into 3 sections:

Top section (a) shows the status when in status mode or up to 2 variables when not in status mode and in the case of Alarm/Warning.

The number of the Active Set-up (selected as the Active Set-up in par. 0-10 [Active Set-up](#)) is shown. When programming in another Set-up than the Active Set-up, the number of the Set-up being programd appears to the right in brackets.

The **Middle section** (b) shows up to 5 variables with related unit, regardless of status. In case of alarm/warning, the warning is shown instead of the variables.

The **Bottom section** (c) always shows the state of the frequency converter in Status mode.

It is possible to toggle between three status read-out displays by pressing the [Status] key. Operating variables with different formatting are shown in each status screen - see below.

Several values or measurements can be linked to each of the displayed operating variables. The values / measurements to be displayed can be defined via par. 0-20 [Display Line 1.1 Small](#), par. 0-21 [Display Line 1.2 Small](#), par. 0-22 [Display Line 1.3 Small](#), par. 0-23 [Display Line 2 Large](#) and par. 0-24 [Display Line 3 Large](#), which can be accessed via [QUICK MENU], "Q3 Function Setups", "Q3-1 General Settings", "Q3-13 Display Settings".

Each value / measurement readout parameter selected in par. 0-20 [Display Line 1.1 Small](#) to par. 0-24 [Display Line 3 Large](#) has its own scale and number of digits after a possible decimal point. Larger numeric values are displayed with few digits after the decimal point.

Ex.: Current readout
5.25 A; 15.2 A 105 A.

Status display I:

This read-out state is standard after start-up or initialization.

Use [INFO] to obtain information about the value/ measurement linked to the displayed operating variables (1.1, 1.2, 1.3, 2, and 3).

See the operating variables shown in the display in this illustration. 1.1, 1.2 and 1.3 are shown in small size. 2 and 3 are shown in medium size.

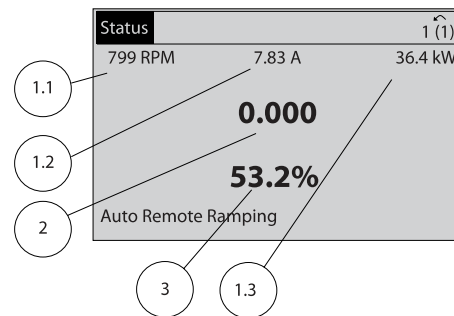

130BP041.10

Status display II:

See the operating variables (1.1, 1.2, 1.3, and 2) shown in the display in this illustration.

In the example, Speed, Motor current, Motor power and Frequency are selected as variables in the first and second lines.

1.1, 1.2 and 1.3 are shown in small size. 2 is shown in large size.

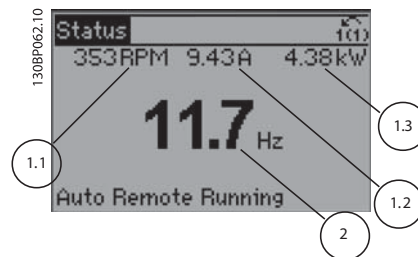

130BP062.10

Status display III:

This state displays the event and action of the Smart Logic Control. For further information, see section *Smart Logic Control*.

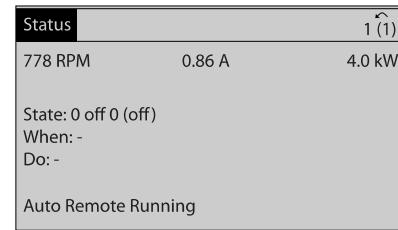

130BP063.10

Display Contrast Adjustment

Press [status] and [▲] for darker display

Press [status] and [▼] for brighter display

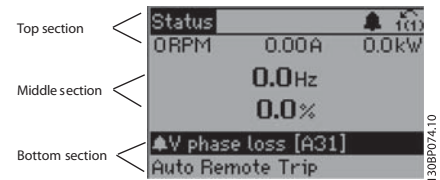

Indicator lights (LEDs):

If certain threshold values are exceeded, the alarm and/or warning LED lights up. A status and alarm text appear on the control panel.

The On LED is activated when the frequency converter receives power from mains voltage, a DC bus terminal, or an external 24 V supply. At the same time, the back light is on.

- Green LED/On: Control section is working.
- Yellow LED/Warn.: Indicates a warning.
- Flashing Red LED/Alarm: Indicates an alarm.

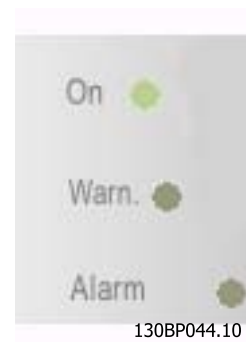

130BP044.10

Keys

Menu keys

The menu keys are divided into functions. The keys below the display and indicator lamps are used for parameter set-up, including choice of display indication during normal operation.



[Status]

indicates the status of the frequency converter and/or the motor. 3 different readouts can be chosen by pressing the [Status] key:

5 line readouts, 4 line readouts or Smart Logic Control.

Use **[Status]** for selecting the mode of display or for changing back to Display mode from either the Quick Menu mode, the Main Menu mode or Alarm mode. Also use the [Status] key to toggle single or double read-out mode.

[Quick Menu]

allows quick set-up of the frequency converter. **The most common TR200 functions can be programd here.**

The [Quick Menu] consists of:

- **My Personal Menu**
- **Quick Set-up**
- **Function Set-up**
- **Changes Made**
- **Loggings**

The Function set-up provides quick and easy access to all parameters required for the majority of TR200 applications including most VAV and CAV supply and return fans, cooling tower fans, Primary, Secondary and Condenser Water Pumps and other pump, fan and compressor applications. Amongst other features it also includes parameters for selecting which variables to display on the keypad, digital preset speeds, scaling of analog references, closed loop single zone and multi-zone applications and specific functions related to Fans, Pumps and Compressors.

The Quick Menu parameters can be accessed immediately unless a password has been created via par. 0-60 [Main Menu Password](#), par. 0-61 [Access to Main Menu w/o Password](#), par. 0-65 [Personal Menu Password](#) or par. 0-66 [Access to Personal Menu w/o Password](#).

It is possible to switch directly between Quick Menu mode and Main Menu mode.

[Main Menu]

is used for programming all parameters. The Main Menu parameters can be accessed immediately unless a password has been created via par. 0-60 [Main Menu Password](#), par. 0-61 [Access to Main Menu w/o Password](#), par. 0-65 [Personal Menu Password](#) or par. 0-66 [Access to Personal Menu w/o Password](#). For the majority of TR200 applications it is not necessary to access the Main Menu parameters but instead the Quick Menu, Quick Set-up and Function Set-up provides the simplest and quickest access to the typical required parameters.

It is possible to switch directly between Main Menu mode and Quick Menu mode.

Parameter shortcut can be carried out by pressing down the **[Main Menu]** key for 3 seconds. The parameter shortcut allows direct access to any parameter.

[Alarm Log]

displays an Alarm list of the five latest alarms (numbered A1-A5). To obtain additional details about an alarm, use the arrow keys to manoeuvre to the alarm number and press [OK]. Information is displayed about the condition of the frequency converter before it enters the alarm mode.

The Alarm log button on the keypad allows access to both Alarm log and Maintenance log.

[Back]

reverts to the previous step or layer in the navigation structure.

[Cancel]

last change or command will be cancelled as long as the display has not been changed.

[Info]

displays information about a command, parameter, or function in any display window. [Info] provides detailed information when needed.

Exit Info mode by pressing either [Info], [Back], or [Cancel].

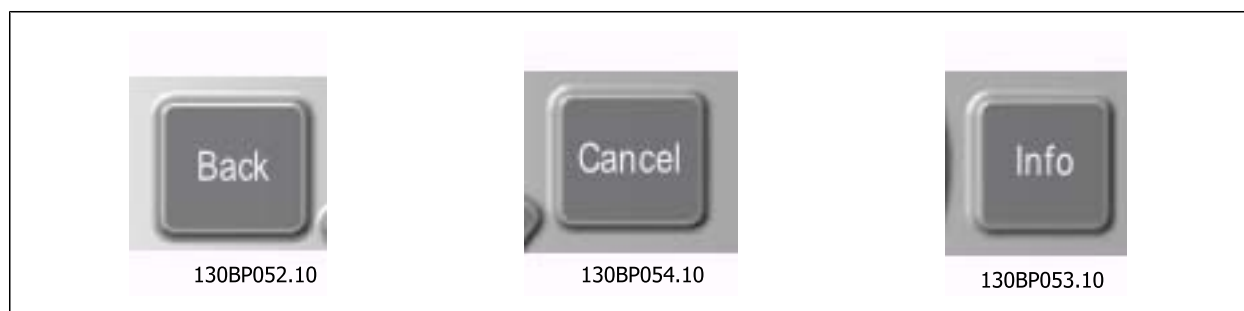

Navigation Keys

The four navigation arrows are used to navigate between the different choices available in **[Quick Menu]**, **[Main Menu]** and **[Alarm Log]**. Use the keys to move the cursor.

[OK] is used for choosing a parameter marked by the cursor and for enabling the change of a parameter.

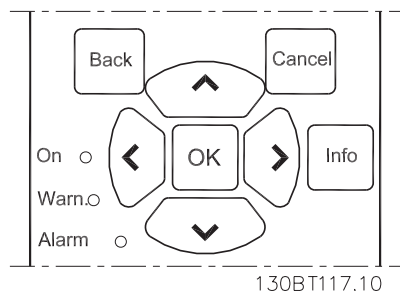

Operation Keys for local control are found at the bottom of the control panel.



[Hand On]

enables control of the frequency converter via the GLCP. [Hand On] also starts the motor, and it is now possible to enter the motor speed data by means of the arrow keys. The key can be selected as *Enable* [1] or *Disable* [0] via par. 0-40 [\[Hand on\] Key on LCP](#).

The following control signals will still be active when [Hand On] is activated:

- [Hand On] - [Off] - [Auto on]
- Reset
- Coasting stop inverse
- Reversing
- Set-up select lsb - Set-up select msb
- Stop command from serial communication
- Quick stop
- DC brake

External stop signals activated by means of control signals or a serial bus will override a "start" command via the keypad.

[Off]

stops the connected motor. The key can be selected as Enable [1] or Disable [0] via par. 0-41 [\[Off\] Key on LCP](#). If no external stop function is selected and the [Off] key is inactive the motor can only be stopped by disconnecting the mains supply.

[Auto on]

enables the frequency converter to be controlled via the control terminals and/or serial communication. When a start signal is applied on the control terminals and/or the bus, the frequency converter will start. The key can be selected as Enable [1] or Disable [0] via par. 0-42 [\[Auto on\] Key on LCP](#).

An active HAND-OFF-AUTO signal via the digital inputs has higher priority than the control keys [Hand on] – [Auto on].

[Reset]

is used for resetting the frequency converter after an alarm (trip). It can be selected as *Enable* [1] or *Disable* [0] via par. 0-43 [\[Reset\] Key on LCP](#).

The parameter shortcut can be carried out by holding down the [Main Menu] key for 3 seconds. The parameter shortcut allows direct access to any parameter.

RS-485 Bus Connection

One or more frequency converters can be connected to a controller (or master) using the RS-485 standard interface. Terminal 68 is connected to the P signal (TX+, RX+), while terminal 69 is connected to the N signal (TX-, RX-).

If more than one frequency converter is connected to a master, use parallel connections.

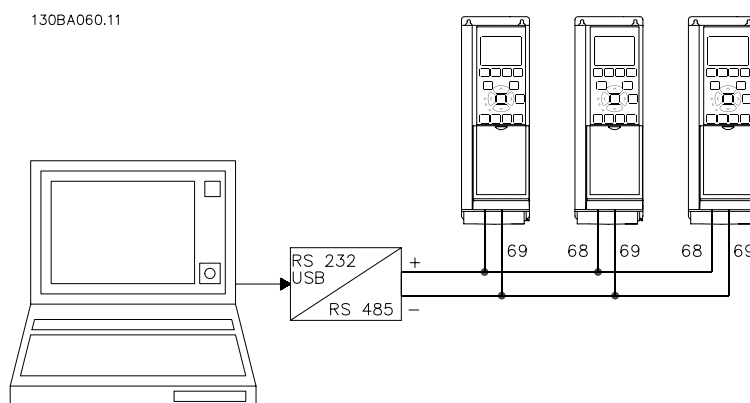

Figure 5. 1: Connection example.

In order to avoid potential equalizing currents in the screen, earth the cable screen via terminal 61, which is connected to the frame via an RC-link.

Bus termination

The RS-485 bus must be terminated by a resistor network at both ends. If the drive is the first or the last device in the RS-485 loop, set the switch S801 on the control card for ON.

For more information, see the paragraph *Switches S201, S202, and S801*.

How to Connect a PC to the Frequency Converter

To control or program the frequency converter from a PC, install the PC-based Configuration Tool TDU. The PC is connected via a standard (host/device) USB cable, or via the RS-485 interface as shown in the TR200 *Design Guide, chapter How to Install > Installation of misc. connections.*

The USB connection is galvanically isolated from the supply voltage (PELV) and other high-voltage terminals. The USB connection is connected to protection earth on the frequency converter. Use only an isolated laptop as PC connection to the USB connector on the frequency converter.

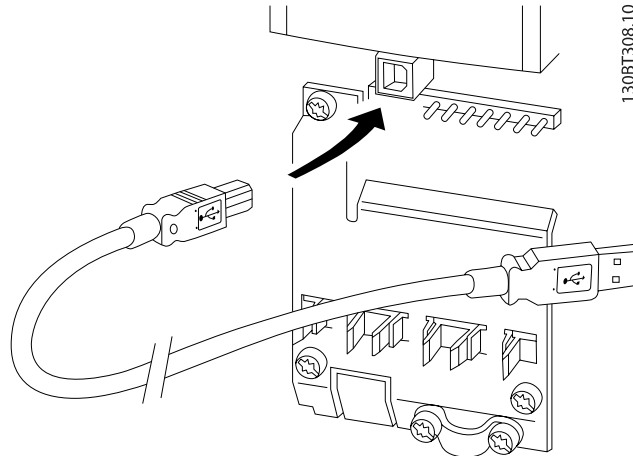

Figure 5. 2: For control cable connections, see section on *Control Terminals*.

PC Software Tools

PC-based Configuration Tool Trane Drive Utility (TDU)

All Frequency converters are equipped with a serial communication port. Trane provides a PC tool for communication between PC and frequency converter, PC-based Configuration Tool TDU. Please check the section on *Available Literature* for detailed information on this tool.

TDU Set-up Software

TDU has been designed as an easy to use interactive tool for setting parameters in our frequency converters. . The TDU Set-up software will be useful for:

- Planning a communication network off-line. TDU contains a complete frequency converter database
- Commissioning frequency converters on line
- Saving settings for all frequency converters
- Replacing a frequency converter in a network
- Simple and accurate documentation of frequency converter settings after commissioning.
- Expanding an existing network
- Future developed frequency converters will be supported

Save frequency converter settings:

1. Connect a PC to the unit via USB com port. (NOTE: Use a PC, which is isolated from the mains, in conjunction with the USB port. Failure to do so may damage equipment.)
2. Open TDU Set-up Software
3. Choose "Read from drive"
4. Choose "Save as"

All parameters are now stored in the PC.

Load frequency converter settings:

1. Connect a PC to the frequency converter via USB com port
2. Open TDU Set-up software
3. Choose "Open" – stored files will be shown
4. Open the appropriate file
5. Choose "Write to drive"

All parameter settings are now transferred to the frequency converter.

A separate manual for TDU Set-up Software is available.

The TDU Set-up software modules

The following modules are included in the software package:

	TDU Set-up Software Setting parameters Copy to and from frequency converters Documentation and print out of parameter settings incl. diagrams
Ext. user interface Preventive Maintenance Schedule Clock settings Timed Action Programming Smart Logic Controller Set-up	

Ordering number:

Please order the CD containing MCT 10 Set-up Software using code number 130B1000.

The Trane Drive Utility software is available for download from www.trane.com/vfd.

Tips and Tricks

- For the majority of HVAC applications the Quick Menu, Quick Set-up and Function Set-up provides the simplest and quickest access to all the typical parameters required
- Whenever possible, performing an AMA, will ensure best shaft performance
- Contrast of the display can be adjusted by pressing [Status] and [▲] for darker display or by pressing [Status] and [▼] for brighter display
- Under [Quick Menu] and [Changes Made] all parameters that have been changed from factory settings are displayed
- Press and hold [Main Menu] key for 3 seconds for access to any parameter
- For service purposes it is recommended to copy all parameters to the keypad, see par. 0-50 [LCP Copy](#) for further information

Quick Transfer of Parameter Settings when using keypad

Once the set-up of a frequency converter is complete, it is recommended to store (backup) the parameter settings in the keypad or on a PC via TDU Set-up Software Tool.

Stop the motor before performing any of these operations otherwise unexpected operation can occur. Disconnect all electric power, including remote disconnects before servicing. Follow proper lockout/tagout procedures to ensure the power can not be inadvertently energized.

Failure to follow recommendations could result in death or serious injury..

Data storage in keypad:

1. Go to par. 0-50 [LCP Copy](#)
2. Press the [OK] key
3. Select "All to keypad"
4. Press the [OK] key

All parameter settings are now stored in the GLCP indicated by the progress bar. When 100% is reached, press [OK].

The GLCP can now be connected to another frequency converter and the parameter settings copied to this frequency converter.

Data transfer from keypad to Frequency converter:

1. Go to par. 0-50 [LCP Copy](#)
2. Press the [OK] key
3. Select "All from keypad"
4. Press the [OK] key

The parameter settings stored in the GLCP are now transferred to the frequency converter indicated by the progress bar. When 100% is reached, press [OK].

Initialization to Default Settings

There are two ways to initialize the frequency converter to default: Recommended initialization and manual initialization.

Please be aware that they have different impact according to the below description.

Recommended initialization (via par. 14-22 [Operation Mode](#))

1. Select par. 14-22 [Operation Mode](#)
2. Press [OK]
3. Select "Initialization"
4. Press [OK]
5. Remove power to unit and wait for display to turn off.
6. Reconnect power and the frequency converter is reset. Note that first start-up takes a few more seconds
7. Press [Reset]

Par. 14-22 [Operation Mode](#) initializes all except:
Par. 14-50 [RFI 1](#)
Par. 8-30 [Protocol](#)
Par. 8-31 [Address](#)
Par. 8-32 [Baud Rate](#)
Par. 8-35 [Minimum Response Delay](#)
Par. 8-36 [Max Response Delay](#)
Par. 8-37 [Max Inter-Char Delay](#)
Par. 15-00 [Operating Hours](#) to par. 15-05 [Over Volts](#)
Par. 15-20 [Historic Log: Event](#) to par. 15-22 [Historic Log: Time](#)
Par. 15-30 [Alarm Log: Error Code](#) to par. 15-32 [Alarm Log: Time](#)

Parameters selected in par. 0-25 [My Personal Menu](#), will stay present, with default factory setting.

Manual initialization

When carrying out manual initialization, serial communication, RFI filter settings and fault log settings are reset. Removes parameters selected in par. 0-25 [My Personal Menu](#).

1. Disconnect from mains and wait until the display turns off.
 - 2a. Press [Status] - [Main Menu] - [OK] at the same time while power up for Graphical LCP (GLCP)
3. Release the keys after 5 s
4. The frequency converter is now programd according to default settings

This parameter initializes all except:
Par. 15-00 [Operating Hours](#)
Par. 15-03 [Power-ups](#)
Par. 15-04 [Over Temps](#)
Par. 15-05 [Over Volts](#)

How to program the Frequency Converter

Quick Menu Mode

Parameter Data

The keypad provides access to all parameters listed under the Quick Menus. To set parameters using the [Quick Menu] button - enter or change parameter data or settings in accordance with the following procedure:

1. Press Quick Menu button
2. Use the [▲] and [▼] buttons to find the parameter you want to change
3. Press [OK]
4. Use [▲] and [▼] buttons to select the correct parameter setting
5. Press [OK]
6. To move to a different digit within a parameter setting, use the [◀] and [▶] buttons
7. Highlighted area indicates digit selected for change
8. Press [Cancel] button to disregard change, or press [OK] to accept change and enter the new setting

Example of changing parameter data

Assume parameter 22-60 is set to [Off]. However, you want to monitor the fan-belt condition - non- broken or broken - according to the following procedure:

1. Press Quick Menu key
2. Choose Function Setups with the [▼] button
3. Press [OK]
4. Choose Application Settings with the [▼] button
5. Press [OK]
6. Press [OK] again for Fan Functions
7. Choose Broken Belt Function by pressing [OK]
8. With [▼] button, choose [2] Trip

The frequency converter will now trip if a broken fan-belt is detected.

Select [My Personal Menu] to display personal parameters:

For example, you may have pre-programd personal parameters to be in My Personal Menu during factory commissioning to make on-site commissioning/fine tuning simpler. These parameters are selected in par. 0-25 [My Personal Menu](#). Up to 20 different parameters can be programd in this menu.

Select [Changes Made] to get information about:

- The last 10 changes. Use the up/down navigation keys to scroll between the last 10 changed parameters.
- The changes made since default setting.

Select [Loggings]:

to get information about the display line read-outs. The information is shown as graphs.

Only display parameters selected in par. 0-20 [Display Line 1.1 Small](#) and par. 0-24 [Display Line 3 Large](#) can be viewed. It is possible to store up to 120 samples in the memory for later reference.

Efficient Parameter Set-up for TR200 Applications:

The parameters can easily be set up for the vast majority of the TR200 applications only by using the **[Quick Setup]** option.

After pressing [Quick Menu], the different choices in the Quick Menu are listed. See also illustration 6.1 below and tables Q3-1 to Q3-4 in the following *Function Setups* section.

Example of using the Quick Setup option:

Assume you want to set the Ramp Down Time to 100 seconds:

1. Select [Quick Setup]. The first par. 0-01 [Language](#) in Quick Setup appears
2. Press [▼] repeatedly until par. 3-42 [Ramp 1 Ramp-down Time](#) appears with the default setting of 20 seconds
3. Press [OK]
4. Use the [◀] button to highlight the 3rd digit before the comma
5. Change '0' to '1' by using the [▲] button
6. Use the [▶] button to highlight the digit '2'
7. Change '2' to '0' with the [▼] button
8. Press [OK]

The new ramp-down time is now set to 100 seconds.
It is recommended to do the set-up in the order listed.

A complete description of the function is found in the parameter sections of this manual.



130BP064.11

Figure 6. 1: Quick Menu view.

The Quick Setup menu gives access to the 18 most important setup parameters of the frequency converter. After programming the frequency converter will, in most cases, be ready for operation. The 18 Quick Setup parameters are shown in the table below. A complete description of the function is given in the parameter description sections of this manual.

Parameter	[Units]
Par. 0-01 Language	
Par. 1-20 Motor Power [kW]	[kW]
Par. 1-21 Motor Power [HP]	[HP]
Par. 1-22 Motor Voltage*	[V]
Par. 1-23 Motor Frequency	[Hz]
Par. 1-24 Motor Current	[A]
Par. 1-25 Motor Nominal Speed	[RPM]
Par. 1-28 Motor Rotation Check	[Hz]
Par. 3-41 Ramp 1 Ramp-up Time	[s]
Par. 3-42 Ramp 1 Ramp-down Time	[s]
Par. 4-11 Motor Speed Low Limit [RPM]	[RPM]
Par. 4-12 Motor Speed Low Limit [Hz]*	[Hz]
Par. 4-13 Motor Speed High Limit [RPM]	[RPM]
Par. 4-14 Motor Speed High Limit [Hz]*	[Hz]
Par. 3-19 Jog Speed [RPM]	[RPM]
Par. 3-11 Jog Speed [Hz]*	[Hz]
Par. 5-12 Terminal 27 Digital Input	
Par. 5-40 Function Relay**	

Table 6. 1: Quick Setup parameters

*The display showing depends on choices made in par. 0-02 [Motor Speed Unit](#) and par. 0-03 [Regional Settings](#). The default settings of par. 0-02 [Motor Speed Unit](#) and par. 0-03 [Regional Settings](#) depend on which region of the world the frequency converter is supplied to but can be re-programd as required.

** Par. 5-40 [Function Relay](#), is an array, where one may choose between Relay1 [0] or Relay2 [1]. Standard setting is Relay1 [0] with the default choice Alarm [9].

See the parameter description in the section *Commonly Used Parameters*.

For a detailed information about settings and programming, please see the *TR200 Programming Guide*

If [No Operation] is selected in par. 5-12 [Terminal 27 Digital Input](#), no connection to +24 V on terminal 27 is necessary to enable start.

If [Coast Inverse] (factory default value) is selected in par. 5-12 [Terminal 27 Digital Input](#), a connection to +24V is necessary to enable start.

Quick Set-up parameters

Parameters for Quick Set-up

0-01 Language

Option:	Function:
	Defines the language to be used in the display. The frequency converter can be delivered with 2 different language packages. English and German are included in both packages. English cannot be erased or manipulated.
[0] * English	Part of Language packages 1 - 2
[1] Deutsch	Part of Language packages 1 - 2
[2] Francais	Part of Language package 1
[3] Dansk	Part of Language package 1
[4] Spanish	Part of Language package 1
[5] Italiano	Part of Language package 1
[6] Svenska	Part of Language package 1
[7] Nederlands	Part of Language package 1
[10] Chinese	Language package 2
[20] Suomi	Part of Language package 1
[22] English US	Part of Language package 1
[27] Greek	Part of Language package 1
[28] Bras.port	Part of Language package 1
[36] Slovenian	Part of Language package 1
[39] Korean	Part of Language package 2
[40] Japanese	Part of Language package 2
[41] Turkish	Part of Language package 1
[42] Trad.Chinese	Part of Language package 2
[43] Bulgarian	Part of Language package 1
[44] Srpski	Part of Language package 1
[45] Romanian	Part of Language package 1
[46] Magyar	Part of Language package 1
[47] Czech	Part of Language package 1
[48] Polski	Part of Language package 1
[49] Russian	Part of Language package 1
[50] Thai	Part of Language package 2
[51] Bahasa Indonesia	Part of Language package 2

1-20 Motor Power [kW]

Range:

Function:

Applica- [Application dependant]
tion de-
pend-
ent*

Enter the nominal motor power in kW according to the motor nameplate data. The default value corresponds to the nominal rated output of the unit.

This parameter cannot be adjusted while the motor is running. Depending on the choices made in par. 0-03 [Regional Settings](#), either par. 1-20 [Motor Power \[kW\]](#) or par. 1-21 [Motor Power \[HP\]](#) is made invisible.

1-21 Motor Power [HP]

Range:

Function:

Applica- [Application dependant]
tion de-
pend-
ent*

Enter the nominal motor power in HP according to the motor nameplate data. The default value corresponds to the nominal rated output of the unit.

This parameter cannot be adjusted while the motor is running. Depending on the choices made in par. 0-03 [Regional Settings](#), either par. 1-20 [Motor Power \[kW\]](#) or par. 1-21 [Motor Power \[HP\]](#) is made invisible.

1-22 Motor Voltage

Range:

Function:

Applica- [Application dependant]
tion de-
pend-
ent*

Enter the nominal motor voltage according to the motor nameplate data. The default value corresponds to the nominal rated output of the unit. This parameter cannot be adjusted while the motor is running.

1-23 Motor Frequency

Range:

Function:

Applica- [20 - 1000 Hz]
tion de-
pend-
ent*Select the motor frequency value from the motor nameplate data. For 87 Hz operation with 230/400 V motors, set the nameplate data for 230 V/50 Hz. Adapt par. 4-13 [Motor Speed High Limit \[RPM\]](#) and par. 3-03 [Maximum Reference](#) to the 87 Hz application.

This parameter cannot be adjusted while the motor is running.

1-24 Motor Current

Range:

Function:

Applica- [Application dependant]
tion de-
pend-
ent*

Enter the nominal motor current value from the motor nameplate data. This data is used for calculating motor torque, motor thermal protection etc.

This parameter cannot be adjusted while the motor is running.

1-25 Motor Nominal Speed

Range:

Function:

Applica- [100 - 60000 RPM]
tion de-
pend-
ent*

Enter the nominal motor speed value from the motor nameplate data. This data is used for calculating automatic motor compensations.

This parameter cannot be adjusted while the motor is running.

1-28 Motor Rotation Check

Option:

Function:

Following installation and connection of the motor, this function allows the correct motor rotation direction to be verified. Enabling this function overrides any bus commands or digital inputs, except External Interlock.

[0] * OFF

Motor Rotation Check is not active.

[1] Enabled

Motor Rotation Check is enabled. Once enabled, Display shows: "Note! Motor may run in wrong direction".

Pressing [OK], [Back] or [Cancel] will dismiss the message and display a new message: "Press [Hand on] to start the motor. Press [Cancel] to abort". Pressing [Hand on] starts the motor at 5 Hz in forward direction and the display shows: "Motor is running. Check if motor rotation direction is correct. Press [Off] to stop the motor". Pressing [Off] stops the motor and resets par. 1-28 [Motor Rotation Check](#). If motor rotation direction is incorrect, two motor phase cables should be interchanged. **IMPORTANT:**

Hazardous Voltage!

Main power must be removed before disconnecting motor phase cables. Failure to follow recommendation could result in death or serious injury.

3-41 Ramp 1 Ramp-up Time

Range:

Function:

Application dependent*

Enter the ramp-up time, i.e. the acceleration time from 0 RPM to par. 1-25 [Motor Nominal Speed](#). Choose a ramp-up time such that the output current does not exceed the current limit in par. 4-18 [Current Limit](#) during ramping. See ramp-down time in par. 3-42 [Ramp 1 Ramp-down Time](#).

$$par.3 - 41 = \frac{tacc \times nnorm [par.1 - 25]}{ref[rpm]} [s]$$

3-42 Ramp 1 Ramp-down Time

Range:

Function:

Application dependent*

Enter the ramp-down time, i.e. the deceleration time from par. 1-25 [Motor Nominal Speed](#) to 0 RPM. Choose a ramp-down time such that no over-voltage arises in the inverter due to regenerative operation of the motor, and such that the generated current does not exceed the current limit set in par. 4-18 [Current Limit](#). See ramp-up time in par. 3-41 [Ramp 1 Ramp-up Time](#).

$$par.3 - 42 = \frac{tdec \times nnorm [par.1 - 25]}{ref[rpm]} [s]$$

4-11 Motor Speed Low Limit [RPM]

Range:

Function:

Application dependent*

Enter the minimum limit for motor speed. The Motor Speed Low Limit can be set to correspond to the manufacturer's recommended minimum motor speed. The Motor Speed Low Limit must not exceed the setting in par. 4-13 [Motor Speed High Limit \[RPM\]](#).

4-12 Motor Speed Low Limit [Hz]

Range:

Function:

Applica- [Application dependant]
tion de-
pend-
ent*

Enter the minimum limit for motor speed. The Motor Speed Low Limit can be set to correspond to the minimum output frequency of the motor shaft. The Speed Low Limit must not exceed the setting in par. 4-14 [Motor Speed High Limit \[Hz\]](#).

4-13 Motor Speed High Limit [RPM]

Range:

Function:

Applica- [Application dependant]
tion de-
pend-
ent*

Enter the maximum limit for motor speed. The Motor Speed High Limit can be set to correspond to the manufacturer's maximum rated motor. The Motor Speed High Limit must exceed the setting in par. 4-11 [Motor Speed Low Limit \[RPM\]](#). Only par. 4-11 [Motor Speed Low Limit \[RPM\]](#) or par. 4-12 [Motor Speed Low Limit \[Hz\]](#) will be displayed depending on other parameters in the Main Menu and depending on default settings dependant on global location.

Max. output frequency cannot exceed 10% of the inverter switching frequency (par. 14-01 [Switching Frequency](#)).

Any changes in par. 4-13 [Motor Speed High Limit \[RPM\]](#) will reset the value in par. 4-53 [Warning Speed High](#) to the same value as set in par. 4-13 [Motor Speed High Limit \[RPM\]](#).

4-14 Motor Speed High Limit [Hz]

Range:

Function:

Applica- [Application dependant]
tion de-
pend-
ent*

Enter the maximum limit for motor speed. The Motor Speed High Limit can be set to correspond to the manufacturer's recommended maximum of the motor shaft. The Motor Speed High Limit must exceed the in par. 4-12 [Motor Speed Low Limit \[Hz\]](#). Only par. 4-11 [Motor Speed Low Limit \[RPM\]](#) or par. 4-12 [Motor Speed Low Limit \[Hz\]](#) will be displayed depending on other parameters in the Main Menu and depending on default settings dependant on global location.

NOTE

Max. output frequency cannot exceed 10% of the inverter switching frequency (par. 14-01 [Switching Frequency](#)).

3-19 Jog Speed [RPM]

Range:

Function:

Applica- [Application dependant]
tion de-
pend-
ent*

Enter a value for the jog speed n_{JOG} , which is a fixed output speed. The frequency converter runs at this speed when the jog function is activated. The maximum limit is defined in par. . See also par. 3-80 [Jog Ramp Time](#).

3-11 Jog Speed [Hz]

Range:

Function:

Applica- [Application dependant]
tion de-
pend-
ent*

The jog speed is a fixed output speed at which the frequency converter is running when the jog function is activated. See also par. 3-80 [Jog Ramp Time](#).

Applica- [Application dependant]
tion de-
pend-
ent*

5-12 Terminal 27 Digital Input

Same options and functions as par. 5-1*, except for *Pulse input*.

Option:

Function:

[0] *	No operation
[1]	Reset
[2]	Coast inverse
[3]	Coast and Reset Inv
[5]	DC brake inverse
[6]	Stop inverse
[7]	External interlock
[8]	Start
[9]	Latched start
[10]	Reverse
[11]	Start reverse
[14]	Jog
[15]	Preset reference on
[16]	Preset ref bit 0
[17]	Preset ref bit 1
[18]	Preset ref bit 2
[19]	Freeze reference
[20]	Freeze output
[21]	Speed up
[22]	Slow
[23]	Set-up select bit 0
[24]	Set-up select bit 1
[34]	Ramp bit 0
[36]	Mains failure inverse
[37]	Fire Mode
[52]	Run permissive
[53]	Hand start
[54]	Auto-start
[55]	DigiPot increase
[56]	DigiPot decrease
[57]	DigiPot clear
[62]	Reset Counter A
[65]	Reset Counter B
[66]	Sleep Mode
[67]	No Flow
[68]	Timed Actions Disabled
[69]	Constant OFF Actions
[70]	Constant ON Actions
[78]	Reset Preventive Maintenance Word

5-40 Function Relay

Array [8]

(Relay 1 [0], Relay 2 [1])

Option MCB 105: Relay 7 [6], Relay 8 [7] and Relay 9 [8]).

Select options to define the function of the relays.

The selection of each mechanical relay is realised in an array parameter.

Option:

Function:

[0] *	No operation	
[1]	Control ready	
[2]	Drive ready	
[3]	Drive rdy/rem ctrl	
[4]	Stand-by / no warning	
[5] *	Running	Default setting for relay 2.
[6]	Running / no warning	
[8]	Run on ref/no warn	
[9] *	Alarm	Default setting for relay 1.
[10]	Alarm or warning	
[11]	At torque limit	
[12]	Out of current range	
[13]	Below current, low	
[14]	Above current, high	
[15]	Out of speed range	
[16]	Below speed, low	
[17]	Above speed, high	
[18]	Out of feedb. range	
[19]	Below feedback, low	
[20]	Above feedback, high	
[21]	Thermal warning	
[25]	Reverse	
[26]	Bus OK	
[27]	Torque limit stop	
[28]	Brake: No Brake War	
[29]	Brake ready, no fault	
[30]	Brake fault (IGBT)	
[35]	External Interlock	
[36]	Control word bit 11	
[37]	Control word bit 12	
[40]	Out of ref range	
[41]	Below reference, low	
[42]	Above ref, high	
[45]	Bus ctrl.	
[46]	Bus ctrl, 1 if timeout	
[47]	Bus ctrl, 0 if timeout	
[60]	Comparator 0	
[61]	Comparator 1	
[62]	Comparator 2	
[63]	Comparator 3	

[64]	Comparator 4
[65]	Comparator 5
[70]	Logic rule 0
[71]	Logic rule 1
[72]	Logic rule 2
[73]	Logic rule 3
[74]	Logic rule 4
[75]	Logic rule 5
[80]	SL digital output A
[81]	SL digital output B
[82]	SL digital output C
[83]	SL digital output D
[84]	SL digital output E
[85]	SL digital output F
[160]	No alarm
[161]	Running reverse
[165]	Local ref active
[166]	Remote ref active
[167]	Start cmd. active
[168]	Hand mode
[169]	Auto mode
[180]	Clock Fault
[181]	Prev. Maintenance
[190]	No-Flow
[193]	Sleep Mode
[194]	Broken Belt
[195]	Bypass Valve Control
[196]	Fire Mode Active
[197]	Fire Mode Was Active
[198]	Bypass Mode Active
[220]	Run Confirmation

Function Set-ups

The Function set-up provides quick and easy access to all parameters required for the majority of TR200 applications including most VAV and CAV supply and return fans, cooling tower fans, Primary, Secondary and Condenser Water Pumps and other pump, fan and compressor applications.

How to access Function set-up - example

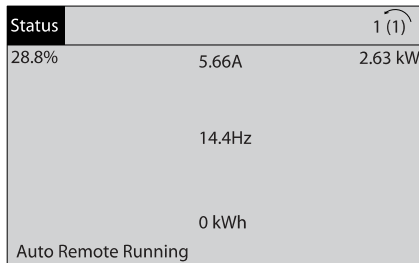

130BT110.10

Figure 6. 2: Step 1: Turn on the frequency converter (yellow LED lights)

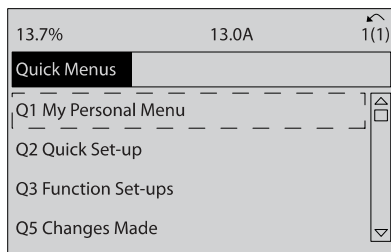

130BT111.10

Figure 6. 3: Step 2: Press the [Quick Menus] button (Quick Menus choices appear).

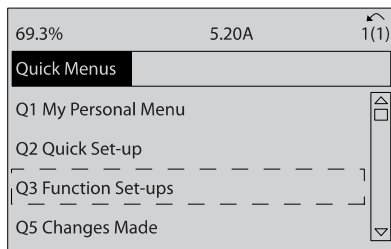

130BT112.10

Figure 6. 4: Step 3: Use the up/down navigation keys to scroll down to Function set-ups. Press [OK].

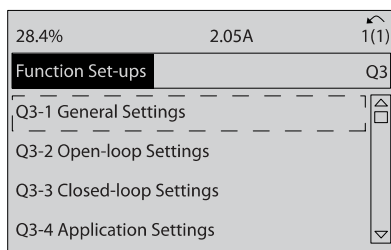

130BT113.10

Figure 6. 5: Step 4: Function set-ups choices appear. Choose Q3-1 *General Settings*. Press [OK].

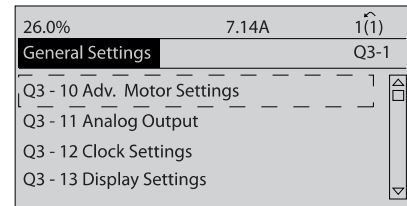

130BT114.10

Figure 6. 6: Step 5: Use the up/down navigation keys to scroll down to i.e. Q3-11 *Analog Outputs*. Press [OK].

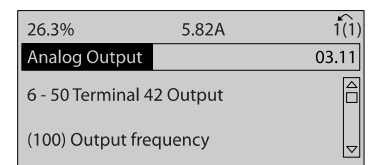

130BT115.10

Figure 6. 7: Step 6: Choose par. 6-50. Press [OK].

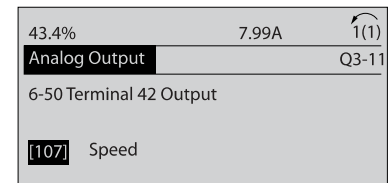

130BT116.10

Figure 6. 8: Step 7: Use the up/down navigation keys to select between the different choices. Press [OK].

How to program the Frequency Converter

Function Set-ups parameters

The Function Set-ups parameters are grouped in the following way:

Q3-1 General Settings			
Q3-10 Adv. Motor Set-tings	Q3-11 Analog Output	Q3-12 Clock Settings	Q3-13 Display Settings
Par. 1-90 Motor Thermal Protection	Par. 6-50 Terminal 42 Output	Par. 0-70 Set Date and Time	Par. 0-20 Display Line 1.1 Small
Par. 1-93 Thermistor Source	Par. 6-51 Terminal 42 Output Min Scale	Par. 0-71 Date Format	Par. 0-21 Display Line 1.2 Small
Par. 1-29 Automatic Motor Adaptation (AMA)	Par. 6-52 Terminal 42 Output Max Scale	Par. 0-72 Time Format	Par. 0-22 Display Line 1.3 Small
Par. 14-01 Switching Frequency		Par. 0-74 DST/Summer-time	Par. 0-23 Display Line 2 Large
Par. 4-53 Warning Speed High		Par. 0-76 DST/Summer-time Start	Par. 0-24 Display Line 3 Large
		Par. 0-77 DST/Summer-time End	Par. 0-37 Display Text 1
			Par. 0-38 Display Text 2
			Par. 0-39 Display Text 3

Q3-2 Open Loop Settings	
Q3-20 Digital Reference	Q3-21 Analog Reference
Par. 3-02 Minimum Reference	Par. 3-02 Minimum Reference
Par. 3-03 Maximum Reference	Par. 3-03 Maximum Reference
Par. 3-10 Preset Reference	Par. 6-10 Terminal 53 Low Voltage
Par. 5-13 Terminal 29 Digital Input	Par. 6-11 Terminal 53 High Voltage
Par. 5-14 Terminal 32 Digital Input	Par. 6-12 Terminal 53 Low Current
Par. 5-15 Terminal 33 Digital Input	Par. 6-13 Terminal 53 High Current
	Par. 6-14 Terminal 53 Low Ref./Feedb. Value
	Par. 6-15 Terminal 53 High Ref./Feedb. Value

Q3-3 Closed Loop Settings	
Q3-30 Single Zone Int. Set Point	Q3-31 Single Zone Ext. Set Point
Par. 1-00 Configuration Mode	Par. 1-00 Configuration Mode
Par. 20-12 Reference/Feedback Unit	Par. 20-12 Reference/Feedback Unit
Par. 20-13 Minimum Reference/Feedb.	Par. 20-13 Minimum Reference/Feedb.
Par. 20-14 Maximum Reference/Feedb.	Par. 20-14 Maximum Reference/Feedb.
Par. 6-22 Terminal 54 Low Current	Par. 6-10 Terminal 53 Low Voltage
Par. 6-24 Terminal 54 Low Ref./Feedb. Value	Par. 6-11 Terminal 53 High Voltage
Par. 6-25 Terminal 54 High Ref./Feedb. Value	Par. 6-12 Terminal 53 Low Current
Par. 6-26 Terminal 54 Filter Time Constant	Par. 6-13 Terminal 53 High Current
Par. 6-27 Terminal 54 Live Zero	Par. 6-14 Terminal 53 Low Ref./Feedb. Value
Par. 6-00 Live Zero Timeout Time	Par. 6-15 Terminal 53 High Ref./Feedb. Value
Par. 6-01 Live Zero Timeout Function	Par. 6-22 Terminal 54 Low Current
Par. 20-21 Setpoint 1	Par. 6-24 Terminal 54 Low Ref./Feedb. Value
Par. 20-81 PID Normal/ Inverse Control	Par. 6-25 Terminal 54 High Ref./Feedb. Value
Par. 20-82 PID Start Speed [RPM]	Par. 6-26 Terminal 54 Filter Time Constant
Par. 20-83 PID Start Speed [Hz]	Par. 6-27 Terminal 54 Live Zero
Par. 20-93 PID Proportional Gain	Par. 6-00 Live Zero Timeout Time
Par. 20-94 PID Integral Time	Par. 6-01 Live Zero Timeout Function
Par. 20-70 Closed-loop Type	Par. 20-81 PID Normal/ Inverse Control
Par. 20-71 Tuning Mode	Par. 20-82 PID Start Speed [RPM]
Par. 20-72 PID Output Change	Par. 20-83 PID Start Speed [Hz]
Par. 20-73 Minimum Feedback Level	Par. 20-93 PID Proportional Gain
Par. 20-74 Maximum Feedback Level	Par. 20-94 PID Integral Time
Par. 20-79 PID Auto Tuning	Par. 20-70 Closed-loop Type
	Par. 20-71 Tuning Mode
	Par. 20-72 PID Output Change
	Par. 20-73 Minimum Feedback Level
	Par. 20-74 Maximum Feedback Level
	Par. 20-79 PID Auto Tuning

Q3-32 Multi Zone / Adv

Par. 1-00	Configuration Mode
Par. 3-15	Reference 1 Source
Par. 3-16	Reference 2 Source
Par. 20-00	Feedback 1 Source
Par. 20-01	Feedback 1 Conversion
Par. 20-02	Feedback 1 Source Unit
Par. 20-03	Feedback 2 Source
Par. 20-04	Feedback 2 Conversion
Par. 20-05	Feedback 2 Source Unit
Par. 20-06	Feedback 3 Source
Par. 20-07	Feedback 3 Conversion
Par. 20-08	Feedback 3 Source Unit
Par. 20-12	Reference/Feedback Unit
Par. 20-13	Minimum Reference/Feedb.
Par. 20-14	Maximum Reference/Feedb.
Par. 6-10	Terminal 53 Low Voltage
Par. 6-11	Terminal 53 High Voltage
Par. 6-12	Terminal 53 Low Current
Par. 6-13	Terminal 53 High Current
Par. 6-14	Terminal 53 Low Ref./Feedb. Value
Par. 6-15	Terminal 53 High Ref./Feedb. Value
Par. 6-16	Terminal 53 Filter Time Constant
Par. 6-17	Terminal 53 Live Zero
Par. 6-20	Terminal 54 Low Voltage
Par. 6-21	Terminal 54 High Voltage
Par. 6-22	Terminal 54 Low Current
Par. 6-23	Terminal 54 High Current
Par. 6-24	Terminal 54 Low Ref./Feedb. Value
Par. 6-25	Terminal 54 High Ref./Feedb. Value
Par. 6-26	Terminal 54 Filter Time Constant
Par. 6-27	Terminal 54 Live Zero
Par. 6-00	Live Zero Timeout Time
Par. 6-01	Live Zero Timeout Function
Par. 4-56	Warning Feedback Low
Par. 4-57	Warning Feedback High
Par. 20-20	Feedback Function
Par. 20-21	Setpoint 1
Par. 20-22	Setpoint 2
Par. 20-81	PID Normal/ Inverse Control
Par. 20-82	PID Start Speed [RPM]
Par. 20-83	PID Start Speed [Hz]
Par. 20-93	PID Proportional Gain
Par. 20-94	PID Integral Time
Par. 20-70	Closed-loop Type
Par. 20-71	Tuning Mode
Par. 20-72	PID Output Change
Par. 20-73	Minimum Feedback Level
Par. 20-74	Maximum Feedback Level
Par. 20-79	PID Auto Tuning

Q3-4 Application Settings		
Q3-40 Fan Functions Par. 22-60 Broken Belt Function Par. 22-61 Broken Belt Torque Par. 22-62 Broken Belt Delay Par. 4-64 Semi-Auto Bypass Set-up Par. 1-03 Torque Characteristics Par. 22-22 Low Speed Detection Par. 22-23 No-Flow Function Par. 22-24 No-Flow Delay Par. 22-40 Minimum Run Time Par. 22-41 Minimum Sleep Time Par. 22-42 Wake-up Speed [RPM] Par. 22-43 Wake-up Speed [Hz] Par. 22-44 Wake-up Ref./FB Difference Par. 22-45 Setpoint Boost Par. 22-46 Maximum Boost Time Par. 2-10 Brake Function Par. 2-16 AC Brake Max. Current Par. 2-17 Over-voltage Control Par. 1-73 Flying Start Par. 1-71 Start Delay Par. 1-80 Function at Stop Par. 2-00 DC Hold/Preheat Current Par. 4-10 Motor Speed Direction	Q3-41 Pump Functions Par. 22-22 Low Speed Detection Par. 22-23 No-Flow Function Par. 22-24 No-Flow Delay Par. 22-40 Minimum Run Time Par. 22-41 Minimum Sleep Time Par. 22-42 Wake-up Speed [RPM] Par. 22-43 Wake-up Speed [Hz] Par. 22-44 Wake-up Ref./FB Difference Par. 22-45 Setpoint Boost Par. 22-46 Maximum Boost Time Par. 1-03 Torque Characteristics Par. 1-73 Flying Start	Q3-42 Compressor Functions Par. 1-03 Torque Characteristics Par. 1-71 Start Delay Par. 22-75 Short Cycle Protection Par. 22-76 Interval between Starts Par. 22-77 Minimum Run Time Par. 5-01 Terminal 27 Mode Par. 5-02 Terminal 29 Mode Par. 5-12 Terminal 27 Digital Input Par. 5-13 Terminal 29 Digital Input Par. 5-40 Function Relay par. 1-73 Flying Start Par. 1-86 Trip Speed Low [RPM] Par. 1-87 Trip Speed Low [Hz]

0-20 Display Line 1.1 Small

Option:	Function:
	Select a variable for display in line 1, left position.
[0] * None	No display value selected
[37] Display Text 1	Enables an individual text string to be written, for display in the keypad or to be read via serial communication.
[38] Display Text 2	Enables an individual text string to be written, for display in the keypad or to be read via serial communication.
[39] Display Text 3	Enables an individual text string to be written, for display in the keypad or to be read via serial communication.
[89] Date and Time Readout	Displays the current date and time.
[953] Profibus Warning Word	Displays Profibus communication warnings.
[1005] Readout Transmit Error Counter	View the number of CAN control transmission errors since the last power-up.
[1006] Readout Receive Error Counter	View the number of CAN control receipt errors since the last power-up.
[1007] Readout Bus Off Counter	View the number of Bus Off events since the last power-up.
[1013] Warning Parameter	View a DeviceNet-specific warning word. One separate bit is assigned to every warning.

How to program the Frequency Converter

[1115]	LON Warning Word	Shows the LON-specific warnings.
[1117]	XIF Revision	Shows the version of the external interface file of the Neuron C chip on the LON option.
[1118]	LonWorks Revision	Shows the software version of the application program of the Neuron C chip on the LON option.
[1501]	Running Hours	View the number of running hours of the motor.
[1502]	Input kWh Counter	View the mains power consumption in kWh.
[1600]	Control Word	View the Control Word sent from the frequency converter via the serial communication port in hex code.
[1601]	Reference [Unit]	Total reference (sum of digital/analog/preset/bus/freeze ref./catch up and slow-down) in selected unit.
[1602] *	Reference %	Total reference (sum of digital/analog/preset/bus/freeze ref./catch up and slow-down) in percent.
[1603]	Status Word	Present status word
[1605]	Main Actual Value [%]	View the two-byte word sent with the Status word to the bus Master reporting the Main Actual Value.
[1609]	Custom Readout	View the user-defined readouts as defined in par. 0-30 Custom Readout Unit , par. 0-31 Custom Readout Min Value and par. 0-32 Custom Readout Max Value .
[1610]	Input Power [kW]	Actual power consumed by the motor in kW.
[1611]	Input Power [hp]	Actual power consumed by the motor in HP.
[1612]	Motor voltage	Voltage supplied to the motor.
[1613]	Frequency	Motor frequency, i.e. the output frequency from the frequency converter in Hz.
[1614]	Motor Current	Phase current of the motor measured as effective value.
[1615]	Frequency [%]	Motor frequency, i.e. the output frequency from the frequency converter in percent.
[1616]	Torque [Nm]	Present motor load as a percentage of the rated motor torque.
[1617]	Speed [RPM]	Motor speed reference. Actual speed will depend on slip compensation being used (compensation set in par. 1-62 Slip Compensation). If not used, actual speed will be the value read in the display minus motor slip.
[1618]	Motor Thermal	Thermal load on the motor, calculated by the ETR function. See also parameter group 1-9* Motor Temperature.
[1622]	Torque [%]	Shows the actual torque produced, in percentage.
[1630]	DC Link Voltage	Intermediate circuit voltage in the frequency converter.
[1632]	Brake Energy /s	Present brake power transferred to an external brake resistor. Stated as an instantaneous value.
[1633]	Brake Energy /2 min	Brake power transferred to an external brake resistor. The mean power is calculated continuously for the most recent 120 seconds.
[1634]	Heatsink Temp.	Present heat sink temperature of the frequency converter. The cut-out limit is $95 \pm 5^\circ \text{C}$; cutting back in occurs at $70 \pm 5^\circ \text{C}$.
[1635]	Inverter Thermal	Percentage load of the inverters

[1636]	Inv. Nom. Current	Nominal current of the frequency converter
[1637]	Inv. Max. Current	Maximum current of the frequency converter
[1638]	SL Controller State	State of the event executed by the control
[1639]	Control Card Temp.	Temperature of the control card.
[1643]	Timed Actions Status	
[1650]	External Reference	Sum of the external reference as a percentage, i.e. the sum of analog/pulse/bus.
[1652]	Feedback [Unit]	Reference value from programd digital input(s).
[1653]	Digi Pot Reference	View the contribution of the digital potentiometer to the actual reference Feedback.
[1654]	Feedback 1 [Unit]	View the value of Feedback 1. See also par. 20-0*.
[1655]	Feedback 2 [Unit]	View the value of Feedback 2. See also par. 20-0*.
[1656]	Feedback 3 [Unit]	View the value of Feedback 3. See also par. 20-0*.
[1658]	PID Output [%]	Returns the Drive Closed Loop PID controller output value in percent.
[1660]	Digital Input	Displays the status of the digital inputs. Signal low = 0; Signal high = 1. Regarding order, see par. 16-60 Digital Input . Bit 0 is at the extreme right.
[1661]	Terminal 53 Switch Setting	Setting of input terminal 53. Current = 0; Voltage = 1.
[1662]	Analog Input 53	Actual value at input 53 either as a reference or protection value.
[1663]	Terminal 54 Switch Setting	Setting of input terminal 54. Current = 0; Voltage = 1.
[1664]	Analog Input 54	Actual value at input 54 either as reference or protection value.
[1665]	Analog Output 42 [mA]	Actual value at output 42 in mA. Use par. 6-50 Terminal 42 Output to select the variable to be represented by output 42.
[1666]	Digital Output [bin]	Binary value of all digital outputs.
[1667]	Pulse Input #29 [Hz]	Actual value of the frequency applied at terminal 29 as a pulse input.
[1668]	Pulse Input #33 [Hz]	Actual value of the frequency applied at terminal 33 as a pulse input.
[1669]	Pulse Output #27 [Hz]	Actual value of pulses applied to terminal 27 in digital output mode.
[1670]	Pulse Output #29 [Hz]	Actual value of pulses applied to terminal 29 in digital output mode.
[1671]	Relay Output [bin]	View the setting of all relays.
[1672]	Counter A	View the present value of Counter A.
[1673]	Counter B	View the present value of Counter B.
[1675]	Analog In X30/11	Actual value of the signal on input X30/11 (General Purpose I/O Card. Option)
[1676]	Analog In X30/12	Actual value of the signal on input X30/12 (General Purpose I/O Card. Optional)
[1677]	Analog Out X30/8 [mA]	Actual value at output X30/8 (General Purpose I/O Card. Optional) Use par. 6-60 Terminal X30/8 Output to select the variable to be shown.
[1680]	Fieldbus CTW 1	Control word (CTW) received from the Bus Master.

How to program the Frequency Converter

[1682]	Fieldbus REF 1	Main reference value sent with control word via the serial communications network e.g. from the BMS, PLC or other master controller.
[1684]	Comm. Option Status	Extended fieldbus communication option status word.
[1685]	FC Port CTW 1	Control word (CTW) received from the Bus Master.
[1686]	FC Port REF 1	Status word (STW) sent to the Bus Master.
[1690]	Alarm Word	One or more alarms in a Hex code (used for serial communications)
[1691]	Alarm word 2	One or more alarms in a Hex code (used for serial communications)
[1692]	Warning Word	One or more warnings in a Hex code (used for serial communications)
[1693]	Warning word 2	One or more warnings in a Hex code (used for serial communications)
[1694]	Ext. Status Word	One or more status conditions in a Hex code (used for serial communications)
[1695]	Ext. Status Word 2	One or more status conditions in a Hex code (used for serial communications)
[1696]	Maintenance Word	The bits reflect the status for the programd Preventive Maintenance Events in parameter group 23-1*
[1840]	Analog Input X49/1	
[1841]	Analog Input X49/3	
[1842]	Analog Input X49/5	
[1843]	Analog Output X49/7	
[1844]	Analog Output X49/9	
[1845]	Analog Output X49/11	
[1846]	X49 Digital Output [bin]	
[2117]	Ext. 1 Reference [Unit]	The value of the reference for extended Closed Loop Controller 1
[2118]	Ext. 1 Feedback [Unit]	The value of the feedback signal for extended Closed Loop Controller 1
[2119]	Ext. 1 Output [%]	The value of the output from extended Closed Loop Controller 1
[2137]	Ext. 2 Reference [Unit]	The value of the reference for extended Closed Loop Controller 2
[2138]	Ext. 2 Feedback [Unit]	The value of the feedback signal for extended Closed Loop Controller 2
[2139]	Ext. 2 Output [%]	The value of the output from extended Closed Loop Controller 2
[2157]	Ext. 3 Reference [Unit]	The value of the reference for extended Closed Loop Controller 3
[2158]	Ext. 3 Feedback [Unit]	The value of the feedback signal for extended Closed Loop Controller 3
[2159]	Ext. 3 Output [%]	The value of the output from extended Closed Loop Controller 3
[2316]	Maintenance Text	
[3110]	Bypass Status Word	
[3111]	Bypass Running Hours	
[9913]	Idle time	
[9914]	Paramdb requests in queue	
[9920]	HS Temp. (PC1)	
[9921]	HS Temp. (PC2)	
[9922]	HS Temp. (PC3)	
[9923]	HS Temp. (PC4)	

[9924] HS Temp. (PC5)

[9925] HS Temp. (PC6)

[9926] HS Temp. (PC7)

[9927] HS Temp. (PC8)

Please consult the *TR200 Programming Guide* for detailed information.

0-21 Display Line 1.2 Small

Select a variable for display in line 1, middle position.

Option:

Function:

[1614] * Motor Current

The options are the same as those listed in par. 0-20 [Display Line 1.1 Small](#).

0-22 Display Line 1.3 Small

Select a variable for display in line 1, right position.

Option:

Function:

[1610] * Power [kW]

The options are the same as those listed in par. 0-20 [Display Line 1.1 Small](#).

0-23 Display Line 2 Large

Select a variable for display in line 2.

Option:

Function:

[1613] * Frequency

The options are the same as those listed in par. 0-20 [Display Line 1.1 Small](#).

0-24 Display Line 3 Large

Select a variable for display in line 3.

Option:

Function:

[1502] * kWh Counter

The options are the same as those listed in par. 0-20 [Display Line 1.1 Small](#).

0-37 Display Text 1

Range:

Function:

Applica- [0 - 0]
tion de-
pend-
ent*

In this parameter it is possible to write an individual text string for display in the keypad or to be read via serial communication. If to be displayed permanently select Display Text 1 in par. 0-20 [Display Line 1.1 Small](#), par. 0-21 [Display Line 1.2 Small](#), par. 0-22 [Display Line 1.3 Small](#), par. 0-23 [Display Line 2 Large](#) or par. 0-24 [Display Line 3 Large](#). Use the [▲] or [▼] buttons on the keypad to change a character. Use the [◀] and [▶] buttons to move the cursor. When a character is highlighted by the cursor, it can be changed. Use the [▲] or [▼] buttons on the keypad to change a character. A character can be inserted by placing the cursor between two characters and pressing [▲] or [▼].

0-38 Display Text 2

Range:

Applica- [0 - 0]

tion de-
pend-
ent*

Function:

In this parameter it is possible to write an individual text string for display in the keypad or to be read via serial communication. If to be displayed permanently select Display Text 2 in par. 0-20 [Display Line 1.1 Small](#), par. 0-21 [Display Line 1.2 Small](#), par. 0-22 [Display Line 1.3 Small](#), par. 0-23 [Display Line 2 Large](#) or par. 0-24 [Display Line 3 Large](#). Use the [▲] or [▼] buttons on the keypad to change a character. Use the [◀] and [▶] buttons to move the cursor. When a character is highlighted by the cursor, this character can be changed. A character can be inserted by placing the cursor between two characters and pressing [▲] or [▼].

0-39 Display Text 3

Range:

Applica- [0 - 0]

tion de-
pend-
ent*

Function:

In this parameter it is possible to write an individual text string for display in the keypad or to be read via serial communication. If to be displayed permanently select Display Text 3 in par. 0-20 [Display Line 1.1 Small](#), par. 0-21 [Display Line 1.2 Small](#), par. 0-22 [Display Line 1.3 Small](#), par. 0-23 [Display Line 2 Large](#) or par. 0-24 [Display Line 3 Large](#). Use the [▲] or [▼] buttons on the keypad to change a character. Use the [◀] and [▶] buttons to move the cursor. When a character is highlighted by the cursor, this character can be changed. A character can be inserted by placing the cursor between two characters and pressing [▲] or [▼].

0-70 Set Date and Time

Range:

Applica- [Application dependant]

tion de-
pend-
ent*

Function:

Sets the date and time of the internal clock. The format to be used is set in par. 0-71 [Date Format](#) and par. 0-72 [Time Format](#).

0-71 Date Format

Option:

Function:

Sets the date format to be used in the keypad.

[0] * YYYY-MM-DD

[1] * DD-MM-YYYY

[2] MM/DD/YYYY

0-72 Time Format

Option:

Function:

Sets the time format to be used in the keypad.

[0] * 24 h

[1] 12 h

0-74 DST/Summertime

Option:

Function:

Choose how Daylight Saving Time/Summertime should be handled. For manual DST/Summertime enter the start date and end date in par. 0-76 [DST/Summertime Start](#) and par. 0-77 [DST/Summertime End](#).

[0] * OFF

[2] Manual

0-76 DST/Summertime Start

Range:	Function:
Applica- [Application dependant] tion de- pend- ent*	Sets the date and time when summertime/DST starts. The date is programd in the format selected in par. 0-71 Date Format .

0-77 DST/Summertime End

Range:	Function:
Applica- [Application dependant] tion de- pend- ent*	Sets the date and time when summertime/DST ends. The date is programd in the format selected in par. 0-71 Date Format .

1-00 Configuration Mode

Option:	Function:
[0] * Open-loop	Motor speed is determined by applying a speed reference or by setting desired speed when in Hand Mode. Open Loop is also used if the frequency converter is part of a closed loop control system based on an external PID controller providing a speed reference signal as output.
[3] Closed-loop	Motor Speed will be determined by a reference from the built-in PID controller varying the motor speed as part of a closed loop control process (e.g. constant pressure or flow). The PID controller must be configured in par. 20-** or via the Function Setups accessed by pressing the [Quick Menus] button.

This parameter cannot be changed when motor is running.

When set for Closed Loop, the commands Reversing and Start Reversing will not reverse the direction of the motor.

1-03 Torque Characteristics

Option:	Function:
[0] * Compressor torque	<i>Compressor</i> [0]: For speed control of screw and scroll compressors. Provides a voltage which is optimized for a constant torque load characteristic of the motor in the entire range down to 10 Hz.
[1] Variable torque	<i>Variable Torque</i> [1]: For speed control of centrifugal pumps and fans. Also to be used when controlling more than one motor from the same frequency converter (e.g. multiple condenser fans or cooling tower fans). Provides a voltage which is optimized for a squared torque load characteristic of the motor.
[2] Auto Energy Optim. CT	<i>Auto Energy Optimization Compressor</i> [2]: For optimum energy efficient speed control of screw and scroll compressors. Provides a voltage which is optimized for a constant torque load characteristic of the motor in the entire range down to 15Hz but in addition the AEO feature will adapt the voltage exactly to the current load situation, thereby reducing energy consumption and audible noise from the motor. To obtain optimal performance, the motor power factor cos phi must be set correctly. This value is set in par. 14-43 Motor Cos-Phi . The parameter has a default value which is automatically adjusted when the motor data is programd. These settings will typically ensure optimum motor voltage but if the motor power factor cos phi requires tuning, an AMA function can be

carried out using par. 1-29 [Automatic Motor Adaptation \(AMA\)](#). It is very rarely necessary to adjust the motor power factor parameter manually.

[3] *	Auto Energy Optim. VT	<i>Auto Energy Optimization VT</i> [3]: For optimum energy efficient speed control of centrifugal pumps and fans. Provides a voltage which is optimized for a squared torque load characteristic of the motor but in addition the AEO feature will adapt the voltage exactly to the current load situation, thereby reducing energy consumption and audible noise from the motor. To obtain optimal performance, the motor power factor cos phi must be set correctly. This value is set in par. 14-43 Motor Cos-Phi . The parameter has a default value and is automatically adjusted when the motor data is programd. These settings will typically ensure optimum motor voltage but if the motor power factor cos phi requires tuning, an AMA function can be carried out using par. 1-29 Automatic Motor Adaptation (AMA) . It is very rarely necessary to adjust the motor power factor parameter manually.
-------	-----------------------	--

1-29 Automatic Motor Adaptation (AMA)

Option:	Function:
	The AMA function optimizes dynamic motor performance by automatically optimizing the advanced motor parameters par. 1-30 Stator Resistance (Rs) to par. 1-35 Main Reactance (Xh) while the motor is stationary.
[0] * Off	No function
[1] Enable complete AMA	performs AMA of the stator resistance R_s , the rotor resistance R_r , the stator leakage reactance X_1 , the rotor leakage reactance X_2 and the main reactance X_h .
[2] Enable reduced AMA	Performs a reduced AMA of the stator resistance R_s in the system only. Select this option if an LC filter is used between the frequency converter and the motor.

Activate the AMA function by pressing [Hand on] after selecting [1] or [2]. See also the item *Automatic Motor Adaptation* in the Design Guide. After a normal sequence, the display will read: "Press [OK] to finish AMA". After pressing the [OK] key the frequency converter is ready for operation.

- **For the best adaptation of the frequency converter, run AMA on a cold motor**
- **AMA cannot be performed while the motor is running**

Avoid generating external torque during AMA.

If one of the settings in par. 1-2* Motor Data is changed, par. 1-30 [Stator Resistance \(Rs\)](#) to par. 1-39 [Motor Poles](#), the advanced motor parameters, will return to default setting. This parameter cannot be adjusted while the motor is running.

Full AMA should be run without filter only while reduced AMA should be run with filter.

See section: *Application Examples > Automatic Motor Adaptation* in the Design Guide.

1-71 Start Delay

Range:	Function:
0.0 s* [0.0 - 120.0 s]	The function selected in par. 1-80 Function at Stop is active in the delay period. Enter the time delay required before commencing acceleration.

1-73 Flying Start

Option:

Function:

This function makes it possible to catch a motor which is spinning freely due to a mains drop-out.

When par. 1-73 [Flying Start](#) is enabled, par. 1-71 [Start Delay](#) has no function.

Search direction for flying start is linked to the setting in par. 4-10 [Motor Speed Direction](#).

Clockwise [0]: Flying start search in clockwise direction. If not successful, a DC brake is carried out.

Both Directions [2]: The flying start will first make a search in the direction determined by the last reference (direction). If not finding the speed it will make a search in the other direction. If not successful, a DC brake will be activated in the time set in par. 2-02 [DC Braking Time](#). Start will then take place from 0 Hz.

[0] * Disabled

Select *Disable* [0] if this function is not required

[1] Enabled

Select *Enable* [1] to enable the frequency converter to “catch” and control a spinning motor.

1-80 Function at Stop

Option:

Function:

Select the frequency converter function after a stop command or after the speed is ramped down to the settings in par. 1-81 [Min Speed for Function at Stop \[RPM\]](#).

[0] * Coast

Leaves motor in free mode.

[1] DC Hold/Motor Preheat

Energizes motor with a DC holding current (see par. 2-00 [DC Hold/Preheat Current](#)).

1-86 Trip Speed Low [RPM]

Range:

Function:

0 RPM* [Application dependant]

This parameter is only available if par. 0-02 [Motor Speed Unit](#) is set to [RPM].

1-87 Trip Speed Low [Hz]

Range:

Function:

0.0 Hz* [Application dependant]

This parameter is only available if par. 0-02 [Motor Speed Unit](#) is set to [Hz].

1-90 Motor Thermal Protection

Option:

Function:

The frequency converter determines the motor temperature for motor protection in two different ways:

- Via a thermistor sensor connected to one of the analog or digital inputs (par. 1-93 [Thermistor Source](#)).
- Via calculation (ETR = Electronic Thermal Relay) of the thermal load, based on the actual load and time. The calculated thermal load is compared with the rated motor current $I_{M,N}$ and the rated motor frequency $f_{M,N}$. The calculations estimate the

need for a lower load at lower speed due to less cooling from the fan incorporated in the motor.		
[0] *	No protection	If the motor is continuously overloaded and no warning or trip of frequency converter is wanted.
[1]	Thermistor warning	Activates a warning when the connected thermistor in the motor reacts in the event of motor over-temperature.
[2]	Thermistor trip	Stops (trips) the frequency converter when the connected thermistor in the motor reacts in the event of motor over-temperature.
[3]	ETR warning 1	
[4] *	ETR trip 1	
[5]	ETR warning 2	
[6]	ETR trip 2	
[7]	ETR warning 3	
[8]	ETR trip 3	
[9]	ETR warning 4	
[10]	ETR trip 4	

ETR (Electronic Thermal Relay) functions 1-4 will calculate the load when set-up where they were selected is active. For example ETR-3 starts calculating when set-up 3 is selected. For the North American market: The ETR functions provide class 20 motor overload protection in accordance with NEC.

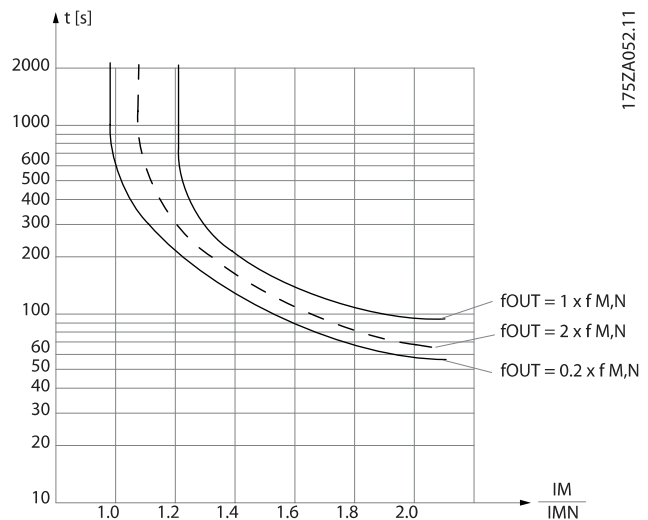

In order to maintain PELV, all connections made to the control terminals must be PELV, e.g. thermistor must be reinforced/ double insulated

Trane recommends using 24 VDC as thermistor supply voltage.

1-93 Thermistor Source

Option:

Function:

Select the input to which the thermistor (PTC sensor) should be connected. An analog input option [1] or [2] cannot be selected if the analog input is already in use as a reference source (selected in par. 3-15 [Reference 1 Source](#), par. 3-16 [Reference 2 Source](#) or par. 3-17 [Reference 3 Source](#)).

[0] *	None
[1]	Analog input 53
[2]	Analog input 54
[3]	Digital input 18
[4]	Digital input 19
[5]	Digital input 32
[6]	Digital input 33

NOTE

This parameter cannot be adjusted while the motor is running.

2-00 DC Hold/Preheat Current

Range:

Function:

50 %* [Application dependant]

Enter a value for holding current as a percentage of the rated motor current $I_{M,N}$ set in par. 1-24 [Motor Current](#). 100% DC holding current corresponds to $I_{M,N}$.

This parameter holds the motor (holding torque) or pre-heats the motor. This parameter is active if [1] DC hold/Preheat is selected in par. 1-80 [Function at Stop](#).

The maximum value depends on the rated motor current.
Avoid 100 % current for too long. It may damage the motor.

2-16 AC brake Max. Current

Range:

Function:

100.0 %* [Application dependant]

Enter the maximum permissible current when using AC brake to avoid overheating of motor windings. The AC brake function is available in Flux mode only.

2-17 Over-voltage Control

Option:

Function:

Over-voltage control (OVC) reduces the risk of the frequency converter tripping due to an over voltage on the DC link caused by generative power from the load.

[0]	Disabled	No OVC required.
[2] *	Enabled	Activates OVC.

The ramp time is automatically adjusted to avoid tripping of the frequency converter.

3-02 Minimum Reference

Range:

Application dependent*

Function:

Enter the Minimum Reference. The Minimum Reference is the lowest value obtainable by summing all references. The Minimum Reference value and unit matches the configuration choice made in par. 1-00 [Configuration Mode](#) and par. 20-12 [Reference/Feedback Unit](#), respectively.

This parameter is used in open loop only.

3-03 Maximum Reference

Range:

Application dependent*

Function:

Enter the maximum acceptable value for the remote reference. The Maximum Reference value and unit matches the configuration choice made in par. 1-00 [Configuration Mode](#) and par. 20-12 [Reference/Feedback Unit](#), respectively.

If operating with par. 1-00 [Configuration Mode](#) set for Closed Loop [3], par. 20-14 [Maximum Reference/Feedb.](#) must be used.

3-10 Preset Reference

Array [8]

Range:

0.00 %* [-100.00 - 100.00 %]

Function:

Enter up to eight different preset references (0-7) in this parameter, using array programming. The preset reference is stated as a percentage of the value Ref_{MAX} (par. 3-03 [Maximum Reference](#), for closed loop see par. 20-14 [Maximum Reference/Feedb.](#)). When using preset references, select Preset ref. bit 0 / 1 / 2 [16], [17] or [18] for the corresponding digital inputs in parameter group 5-1* Digital Inputs.

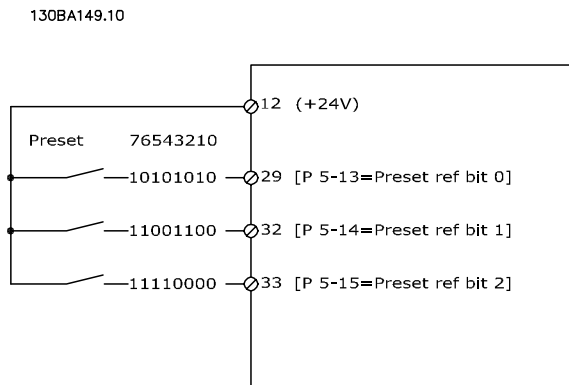
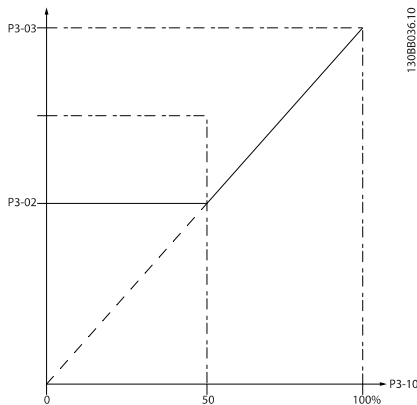

3-15 Reference 1 Source

Option:

Function:

Select the reference input to be used for the first reference signal. Par. 3-15 [Reference 1 Source](#), par. 3-16 [Reference 2 Source](#) and par. 3-17 [Reference 3 Source](#) define up to three different reference signals. The sum of these reference signals defines the actual reference.

This parameter cannot be adjusted while the motor is running.

- [0] No function
- [1] * Analog input 53
- [2] Analog input 54
- [7] Pulse input 29
- [8] Pulse input 33
- [20] Digital pot.meter
- [21] Analog input X30/11
- [22] Analog input X30/12
- [23] Analog Input X42/1
- [24] Analog Input X42/3
- [25] Analog Input X42/5
- [26] Analog Input X49/1
- [27] Analog Input X49/3
- [28] Analog Input X49/5
- [30] Ext. Closed-loop 1
- [31] Ext. Closed-loop 2
- [32] Ext. Closed-loop 3

3-16 Reference 2 Source

Option:

Function:

Select the reference input to be used for the second reference signal. par. 3-15 [Reference 1 Source](#), par. 3-16 [Reference 2 Source](#) and par. 3-17 [Reference 3 Source](#) define up to three different reference signals. The sum of these reference signals defines the actual reference.

This parameter cannot be adjusted while the motor is running.

- [0] No function
- [1] Analog input 53
- [2] Analog input 54
- [7] Pulse input 29
- [8] Pulse input 33
- [20] * Digital pot.meter
- [21] Analog input X30/11
- [22] Analog input X30/12
- [23] Analog Input X42/1
- [24] Analog Input X42/3
- [25] Analog Input X42/5
- [26] Analog Input X49/1
- [27] Analog Input X49/3
- [28] Analog Input X49/5
- [30] Ext. Closed-loop 1

- [31] Ext. Closed-loop 2
- [32] Ext. Closed-loop 3

4-10 Motor Speed Direction

Option:	Function:
	Selects the motor speed direction required. Use this parameter to prevent unwanted reversing.
[0] Clockwise	Only operation in clockwise direction will be allowed.
[2] *	Operation in both clockwise and anti-clockwise direction will be allowed.

The setting in par. 4-10 [Motor Speed Direction](#) has impact on the Flying Start in par. 1-73 [Flying Start](#).

4-53 Warning Speed High

Range:	Function:
Applica- [Application dependant] tion de- pend- ent*	Enter the n_{HIGH} value. When the motor speed exceeds this limit (n_{HIGH}), the display reads SPEED HIGH. The signal outputs can be programd to produce a status signal on terminal 27 or 29 and on relay output 01 or 02. program the upper signal limit of the motor speed, n_{HIGH} , within the normal working range of the frequency converter. Refer to the drawing in this section.

Any changes in par. 4-13 [Motor Speed High Limit \[RPM\]](#) will reset the value in par. 4-53 [Warning Speed High](#) to the same value as set in par. 4-13 [Motor Speed High Limit \[RPM\]](#).

If a different value is needed in par. 4-53 [Warning Speed High](#), it must be set after programming of par. 4-13 [Motor Speed High Limit \[RPM\]](#)

4-56 Warning Feedback Low

Range:	Function:
-999999. [Application dependant] 999 Proc- essCtrlU- nit*	Enter the lower feedback limit. When the feedback falls below this limit, the display reads Feedb Low. The signal outputs can be programd to produce a status signal on terminal 27 or 29 and on relay output 01 or 02.

4-57 Warning Feedback High

Range:	Function:
999999. [Application dependant] 999 Proc- essCtrlU- nit*	Enter the upper feedback limit. When the feedback exceeds this limit, the display reads Feedb High. The signal outputs can be programd to produce a status signal on terminal 27 or 29 and on relay output 01 or 02.

4-64 Semi-Auto Bypass Set-up

Option:	Function:
[0] * OFF	No function
[1] Enabled	Starts the Semi-Automatic Bypass set-up and continue with the procedure described above.

5-01 Terminal 27 Mode

Option:	Function:
[0] * Input	Defines terminal 27 as a digital input.
[1] Output	Defines terminal 27 as a digital output.

5-02 Terminal 29 Mode

Option:	Function:
[0] * Input	Defines terminal 29 as a digital input.
[1] Output	Defines terminal 29 as a digital output.

This parameter cannot be adjusted while the motor is running.

5-1* Digital Inputs

Parameters for configuring the input functions for the input terminals.

The digital inputs are used for selecting various functions in the frequency converter. All digital inputs can be set to the following functions:

Digital input function	Select	Terminal
No operation	[0]	All *terminal 19, 32, 33
Reset	[1]	All
Coast inverse	[2]	27
Coast and reset inverse	[3]	All
DC-brake inverse	[5]	All
Stop inverse	[6]	All
External interlock	[7]	All
Start	[8]	All *terminal 18
Latched start	[9]	All
Reversing	[10]	All
Start reversing	[11]	All
Jog	[14]	All *terminal 29
Preset reference on	[15]	All
Preset ref bit 0	[16]	All
Preset ref bit 1	[17]	All
Preset ref bit 2	[18]	All
Freeze reference	[19]	All
Freeze output	[20]	All
Speed up	[21]	All
Speed down	[22]	All
Set-up select bit 0	[23]	All
Set-up select bit 1	[24]	All
Pulse input	[32]	terminal 29, 33
Ramp bit 0	[34]	All
Mains failure inverse	[36]	All
Fire mode	[37]	All
Run Permissive	[52]	All
Hand start	[53]	All
Auto start	[54]	All
DigiPot Increase	[55]	All
DigiPot Decrease	[56]	All
DigiPot Clear	[57]	All
Counter A (up)	[60]	29, 33
Counter A (down)	[61]	29, 33
Reset Counter A	[62]	All
Counter B (up)	[63]	29, 33
Counter B (down)	[64]	29, 33
Reset Counter B	[65]	All
Sleep Mode	[66]	All
Reset Maintenance Word	[78]	All
Lead Pump Start	[120]	All
Lead Pump Alternation	[121]	All
Pump 1 Interlock	[130]	All
Pump 2 Interlock	[131]	All
Pump 3 Interlock	[132]	All

5-12 Terminal 27 Digital Input

Same options and functions as par. 5-1*, except for *Pulse input*.

Option:

Function:

[0] *	No operation
[1]	Reset
[2]	Coast inverse
[3]	Coast and Reset Inv
[5]	DC brake inverse
[6]	Stop inverse
[7]	External interlock
[8]	Start
[9]	Latched start
[10]	Reverse
[11]	Start reverse
[14]	Jog
[15]	Preset reference on
[16]	Preset ref bit 0
[17]	Preset ref bit 1
[18]	Preset ref bit 2
[19]	Freeze reference
[20]	Freeze output
[21]	Speed up
[22]	Slow
[23]	Set-up select bit 0
[24]	Set-up select bit 1
[34]	Ramp bit 0
[36]	Mains failure inverse
[37]	Fire Mode
[52]	Run permissive
[53]	Hand start
[54]	Auto-start
[55]	DigiPot increase
[56]	DigiPot decrease
[57]	DigiPot clear
[62]	Reset Counter A
[65]	Reset Counter B
[66]	Sleep Mode
[67]	No Flow
[68]	Timed Actions Disabled
[69]	Constant OFF Actions
[70]	Constant ON Actions
[78]	Reset Preventive Maintenance Word

5-15 Terminal 33 Digital Input

Option:

Function:

[0] *	No Operation	Same options and functions as par. 5-1* <i>Digital Inputs</i> .
-------	--------------	---

5-40 Function Relay

Array [8]

(Relay 1 [0], Relay 2 [1])

Option MCB 105: Relay 7 [6], Relay 8 [7] and Relay 9 [8]).

Select options to define the function of the relays.

The selection of each mechanical relay is realised in an array parameter.

Option:

Function:

[0] *	No operation	
[1]	Control ready	
[2]	Drive ready	
[3]	Drive rdy/rem ctrl	
[4]	Stand-by / no warning	
[5] *	Running	Default setting for relay 2.
[6]	Running / no warning	
[8]	Run on ref/no warn	
[9] *	Alarm	Default setting for relay 1.
[10]	Alarm or warning	
[11]	At torque limit	
[12]	Out of current range	
[13]	Below current, low	
[14]	Above current, high	
[15]	Out of speed range	
[16]	Below speed, low	
[17]	Above speed, high	
[18]	Out of feedb. range	
[19]	Below feedback, low	
[20]	Above feedback, high	
[21]	Thermal warning	
[25]	Reverse	
[26]	Bus OK	
[27]	Torque limit stop	
[28]	Brake: No Brake War	
[29]	Brake ready, no fault	
[30]	Brake fault (IGBT)	
[35]	External Interlock	
[36]	Control word bit 11	
[37]	Control word bit 12	
[40]	Out of ref range	
[41]	Below reference, low	
[42]	Above ref, high	
[45]	Bus ctrl.	
[46]	Bus ctrl, 1 if timeout	
[47]	Bus ctrl, 0 if timeout	
[60]	Comparator 0	
[61]	Comparator 1	
[62]	Comparator 2	
[63]	Comparator 3	

[64]	Comparator 4
[65]	Comparator 5
[70]	Logic rule 0
[71]	Logic rule 1
[72]	Logic rule 2
[73]	Logic rule 3
[74]	Logic rule 4
[75]	Logic rule 5
[80]	SL digital output A
[81]	SL digital output B
[82]	SL digital output C
[83]	SL digital output D
[84]	SL digital output E
[85]	SL digital output F
[160]	No alarm
[161]	Running reverse
[165]	Local ref active
[166]	Remote ref active
[167]	Start cmd. active
[168]	Hand mode
[169]	Auto mode
[180]	Clock Fault
[181]	Prev. Maintenance
[190]	No-Flow
[193]	Sleep Mode
[194]	Broken Belt
[195]	Bypass Valve Control
[196]	Fire Mode Active
[197]	Fire Mode Was Active
[198]	Bypass Mode Active
[220]	Run Confirmation

6-00 Live Zero Timeout Time

Range:

10 s* [1 - 99 s]

Function:

Enter the Live Zero Time-out time period. Live Zero Time-out Time is active for analog inputs, i.e. terminal 53 or terminal 54, used as reference or feedback sources. If the reference signal value associated with the selected current input falls below 50% of the value set in par. 6-10 [Terminal 53 Low Voltage](#), par. 6-12 [Terminal 53 Low Current](#), par. 6-20 [Terminal 54 Low Voltage](#) or par. 6-22 [Terminal 54 Low Current](#) for a time period longer than the time set in par. 6-00 [Live Zero Timeout Time](#), the function selected in par. 6-01 [Live Zero Timeout Function](#) will be activated.

6-01 Live Zero Timeout Function

Option:

Function:

Select the time-out function. The function set in par. 6-01 [Live Zero Timeout Function](#) will be activated if the input signal on terminal 53 or 54 is below 50% of the value in par. 6-10 [Terminal 53 Low Voltage](#), par. 6-12 [Terminal 53 Low Current](#), par. 6-20 [Terminal 54 Low Voltage](#) or par. 6-22 [Terminal 54 Low Current](#) for a time period defined in par. 6-00 [Live Zero Timeout Time](#). If several time-outs occur simultaneously, the frequency converter prioritises the time-out functions as follows:

1. Par. 6-01 [Live Zero Timeout Function](#)
2. Par. 8-04 [Control Timeout Function](#)

The output frequency of the frequency converter can be:

- [1] frozen at the present value
- [2] overruled to stop
- [3] overruled to jog speed
- [4] overruled to max. speed
- [5] overruled to stop with subsequent trip

[0] * Off

[1] Freeze output

[2] Stop

[3] Jogging

[4] Max. speed

[5] Stop and trip

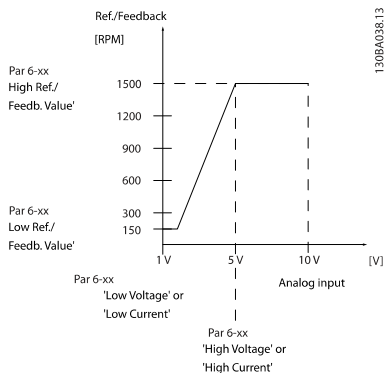

6-10 Terminal 53 Low Voltage

Range:

0.07 V* [Application dependant]

Function:

Enter the low voltage value. This analog input scaling value should correspond to the low reference/feedback value set in par. 6-14 [Terminal 53 Low Ref./Feedb. Value](#).

6-11 Terminal 53 High Voltage

Range:

10.00 V* [Application dependant]

Function:

Enter the high voltage value. This analog input scaling value should correspond to the high reference/feedback value set in par. 6-15 [Terminal 53 High Ref./Feedb. Value](#).

6-12 Terminal 53 Low Current

Range:

Function:

4.00 [Application dependant]
mA*

Enter the low current value. This reference signal should correspond to the low reference/feedback value, set in par. 6-14 [Terminal 53 Low Ref./Feedb. Value](#). The value must be set at >2 mA in order to activate the Live Zero Time-out Function in par. 6-01 [Live Zero Timeout Function](#).

6-13 Terminal 53 High Current

Range:

Function:

20.00 [Application dependant]
mA*

Enter the high current value corresponding to the high reference/feedback set in par. 6-15 [Terminal 53 High Ref./Feedb. Value](#).

6-22 Terminal 54 Low Current

Range:

Function:

4.00 [Application dependant]
mA*

Enter the low current value. This reference signal should correspond to the low reference/feedback value, set in par. 6-24 [Terminal 54 Low Ref./Feedb. Value](#). The value must be set at >2 mA in order to activate the Live Zero Time-out Function in par. 6-01 [Live Zero Timeout Function](#).

6-23 Terminal 54 High Current

Range:

Function:

20.00 [Application dependant]
mA*

Enter the high current value corresponding to the high reference/feedback value set in par. 6-25 [Terminal 54 High Ref./Feedb. Value](#).

6-14 Terminal 53 Low Ref./Feedb. Value

Range:

Function:

0.000* [-999999.999 - 999999.999]

Enter the analog input scaling value that corresponds to the low voltage/low current set in par. 6-10 [Terminal 53 Low Voltage](#) and par. 6-12 [Terminal 53 Low Current](#).

6-15 Terminal 53 High Ref./Feedb. Value

Range:

Function:

Applica- [-999999.999 - 999999.999]
tion de-
pend-
ent*

Enter the analog input scaling value that corresponds to the high voltage/high current value set in par. 6-11 [Terminal 53 High Voltage](#) and par. 6-13 [Terminal 53 High Current](#).

6-16 Terminal 53 Filter Time Constant

Range:

Function:

0.001 s* [0.001 - 10.000 s]

Enter the time constant. This is a first-order digital low pass filter time constant for suppressing electrical noise in terminal 53. A high time constant value improves dampening but also increases the time delay through the filter.

This parameter cannot be adjusted while the motor is running.

6-17 Terminal 53 Live Zero

Option:

Function:

This parameter makes it possible to disable the Live Zero monitoring. E.g. to be used if the analog outputs are used as part of a de-central I/O system (e.g. when not as part of any frequency converter related control functions, but feeding a Building Management system with data).

[0] Disabled

[1] * Enabled

6-20 Terminal 54 Low Voltage

Range:	Function:
0.07 V* [Application dependant]	Enter the low voltage value. This analog input scaling value should correspond to the low reference/feedback value, set in par. 6-24 Terminal 54 Low Ref./Feedb. Value .

6-21 Terminal 54 High Voltage

Range:	Function:
10.00 V* [Application dependant]	Enter the high voltage value. This analog input scaling value should correspond to the high reference/feedback value set in par. 6-25 Terminal 54 High Ref./Feedb. Value .

6-22 Terminal 54 Low Current

Range:	Function:
4.00 mA* [Application dependant]	Enter the low current value. This reference signal should correspond to the low reference/feedback value, set in par. 6-24 Terminal 54 Low Ref./Feedb. Value . The value must be set at >2 mA in order to activate the Live Zero Time-out Function in par. 6-01 Live Zero Timeout Function .

6-23 Terminal 54 High Current

Range:	Function:
20.00 mA* [Application dependant]	Enter the high current value corresponding to the high reference/feedback value set in par. 6-25 Terminal 54 High Ref./Feedb. Value .

6-24 Terminal 54 Low Ref./Feedb. Value

Range:	Function:
0.000* [-999999.999 - 999999.999]	Enter the analog input scaling value that corresponds to the low voltage/low current value set in par. 6-20 Terminal 54 Low Voltage and par. 6-22 Terminal 54 Low Current .

6-25 Terminal 54 High Ref./Feedb. Value

Range:	Function:
100.000* [-999999.999 - 999999.999]	Enter the analog input scaling value that corresponds to the high voltage/high current value set in par. 6-21 Terminal 54 High Voltage and par. 6-23 Terminal 54 High Current .

6-26 Terminal 54 Filter Time Constant

Range:	Function:
0.001 s* [0.001 - 10.000 s]	Enter the time constant. This is a first-order digital low pass filter time constant for suppressing electrical noise in terminal 54. A high time constant value improves dampening but also increases the time delay through the filter. This parameter cannot be adjusted while the motor is running.

6-27 Terminal 54 Live Zero

Option:

Function:

This parameter makes it possible to disable the Live Zero monitoring. E.g. to be used if the analog outputs are used as part of a de-central I/O system (e.g. when not as part of any frequency converter related control functions, but feeding a Building Management System with data).

[0] Disabled

[1] * Enabled

6-50 Terminal 42 Output

Option:

Function:

Select the function of Terminal 42 as an analog current output. A motor current of 20 mA corresponds to I_{max} .

[0] * No operation

[100] Output frequency 0 - 100 Hz, (0-20 mA)

[101] Reference Minimum reference - Maximum reference, (0-20 mA)

 [102] Feedback -200% to +200% of par. 20-14 [Maximum Reference/Feedb.](#), (0-20 mA)

 [103] Motor current 0 - Inverter Max. Current (par. 16-37 [Inv. Max. Current](#)), (0-20 mA)

 [104] Torque rel to limit 0 - Torque limit (par. 4-16 [Torque Limit Motor Mode](#)), (0-20 mA)

[105] Torq relate to rated 0 - Motor rated torque, (0-20 mA)

[106] Power 0 - Motor rated power, (0-20 mA)

 [107] * Speed 0 - Speed High Limit (par. 4-13 [Motor Speed High Limit \[RPM\]](#) and par. 4-14 [Motor Speed High Limit \[Hz\]](#)), (0-20 mA)

[113] Ext. Closed-loop 1 0 - 100%, (0-20 mA)

[114] Ext. Closed-loop 2 0 - 100%, (0-20 mA)

[115] Ext. Closed-loop 3 0 - 100%, (0-20 mA)

[130] Output freq. 4-20mA 0 - 100 Hz

[131] Reference 4-20mA Minimum Reference - Maximum Reference

 [132] Feedback 4-20mA -200% to +200% of par. 20-14 [Maximum Reference/Feedb.](#)

 [133] Motor cur. 4-20mA 0 - Inverter Max. Current (par. 16-37 [Inv. Max. Current](#))

 [134] Torq.% lim 4-20 mA 0 - Torque limit (par. 4-16 [Torque Limit Motor Mode](#))

[135] Torq.% nom 4-20 mA 0 - Motor rated torque

[136] Power 4-20mA 0 - Motor rated power

[137] Speed 4-20mA 0 - Speed High Limit (4-13 and 4-14)

[139] Bus ctrl. 0 - 100%, (0-20 mA)

[140] Bus ctrl. 4-20 mA 0 - 100%

[141] Bus ctrl t.o. 0 - 100%, (0-20 mA)

[142] Bus ctrl 4-20mA t.o. 0 - 100%

[143] Ext. Closed-loop 1 4-20 mA 0 - 100%

[144] Ext. Closed-loop 2 4-20 mA 0 - 100%

[145] Ext. Closed-loop 34-20 mA 0 - 100%

Values for setting the Minimum Reference is found in open loop par. 3-02 [Minimum Reference](#) and for closed loop par. 20-13 [Minimum Reference/Feedb.](#) - values for maximum reference for open loop is found in par. 3-03 [Maximum Reference](#) and for closed loop par. 20-14 [Maximum Reference/Feedb.](#)

6-51 Terminal 42 Output Min Scale

Range:	Function:
0.00 %* [0.00 - 200.00 %]	Scale for the minimum output (0 or 4 mA) of the analog signal at terminal 42. Set the value to be the percentage of the full range of the variable selected in par. 6-50 Terminal 42 Output .

6-52 Terminal 42 Output Max Scale

Range:	Function:
100.00 [0.00 - 200.00 %] %*	Scale for the maximum output (20 mA) of the analog signal at terminal 42. Set the value to be the percentage of the full range of the variable selected in par. 6-50 Terminal 42 Output .

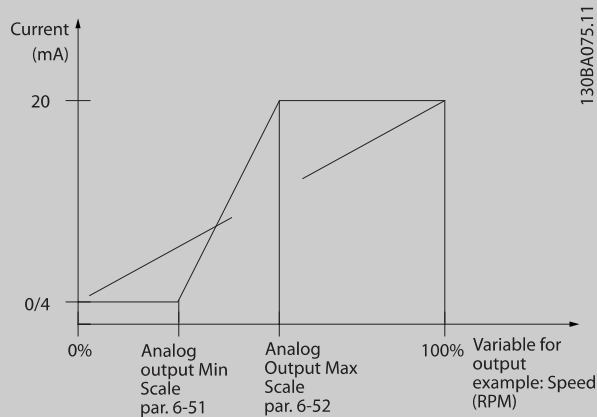

It is possible to get a value lower than 20 mA at full scale by programming values >100% by using a formula as follows:

$$20 \text{ mA} / \text{desired maximum current} \times 100 \%$$

$$\text{i.e. } 10 \text{ mA} : \frac{20 \text{ mA}}{10 \text{ mA}} \times 100 \% = 200 \%$$

EXAMPLE 1:

Variable value= OUTPUT FREQUENCY, range = 0-100 Hz

Range needed for output = 0-50 Hz

Output signal 0 or 4 mA is needed at 0 Hz (0% of range) - set par. 6-51 [Terminal 42 Output Min Scale](#) to 0%

Output signal 20 mA is needed at 50 Hz (50% of range) - set par. 6-52 [Terminal 42 Output Max Scale](#) to 50%

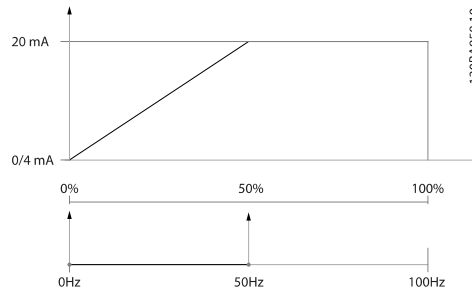

EXAMPLE 2:

Variable= FEEDBACK, range= -200% to +200%

Range needed for output= 0-100%

Output signal 0 or 4 mA is needed at 0% (50% of range) - set par. 6-51 [Terminal 42 Output Min Scale](#) to 50%

Output signal 20 mA is needed at 100% (75% of range) - set par. 6-52 [Terminal 42 Output Max Scale](#) to 75%

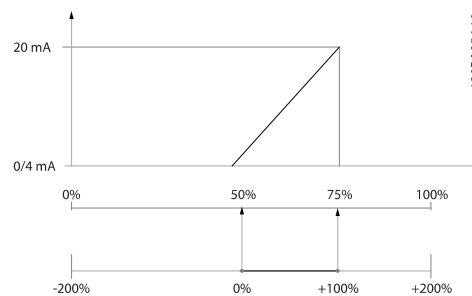

EXAMPLE 3:

Variable value= REFERENCE, range= Min ref - Max ref

Range needed for output= Min ref (0%) - Max ref (100%), 0-10 mA

Output signal 0 or 4 mA is needed at Min ref - set par. 6-51 [Terminal 42 Output Min Scale](#) to 0%

Output signal 10 mA is needed at Max ref (100% of range) - set par. 6-52 [Terminal 42 Output Max Scale](#) to 200% (20 mA / 10 mA x 100%=200%).

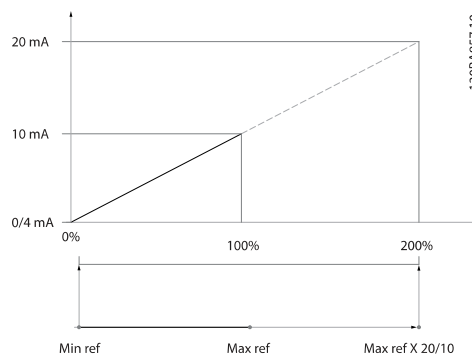

14-01 Switching Frequency

Option:

Function:

Select the inverter switching frequency. Changing the switching frequency can help to reduce acoustic noise from the motor.

NOTE: The output frequency value of the frequency converter must never exceed 1/10 of the switching frequency. When the motor is running, adjust the switching frequency in par. 14-01 [Switching Frequency](#) until the motor is as noiseless as possible. See also par. 14-00 [Switching Pattern](#) and the section *Derating*.

[0]	1.0 kHz
[1]	1.5 kHz
[2]	2.0 kHz
[3]	2.5 kHz
[4]	3.0 kHz
[5]	3.5 kHz
[6]	4.0 kHz
[7] *	5.0 kHz
[8]	6.0 kHz
[9]	7.0 kHz
[10]	8.0 kHz
[11]	10.0 kHz
[12]	12.0 kHz
[13]	14.0 kHz
[14]	16.0 kHz

14-03 Overmodulation

Option:

Function:

[0] Off

Selects no over-modulation of the output voltage in order to avoid torque ripple on the motor shaft.

[1] * On

The over-modulation function generates an extra voltage of up to 8% of U_{max} output voltage without over-modulation, which results in an extra torque of 10-12% in the middle of the over-synchronous range (from 0% at nominal speed rising to approximately 12% at double nominal speed).

20-00 Feedback 1 Source

Option:

Function:

Up to three different feedback signals can be used to provide the feedback signal for the frequency converter's PID Controller.

This parameter defines which input will be used as the source of the first feedback signal.

Analog input X30/11 and Analog input X30/12 refer to inputs on the optional General Purpose I/O board.

[0]	No function
[1]	Analog input 53
[2] *	Analog input 54
[3]	Pulse input 29
[4]	Pulse input 33
[7]	Analog input X30/11
[8]	Analog input X30/12

- [9] Analog Input X42/1
- [10] Analog Input X42/3
- [11] Analog Input X42/5
- [12] Analog Input X49/1
- [13] Analog Input X49/3
- [14] Analog Input X49/5
- [100] Bus feedback 1
- [101] Bus feedback 2
- [102] Bus feedback 3

NOTE: If a feedback is not used, its source must be set to *No Function* [0]. Par. 20-20 [Feedback Function](#) determines how the three possible feedbacks will be used by the PID Controller.

20-01 Feedback 1 Conversion

Option:

Function:

This parameter allows a conversion function to be applied to Feedback 1.

[0] * Linear

Linear [0] has no effect on the feedback.

[1] Square root

Square root [1] is commonly used when a pressure sensor is used to provide flow feedback (($flow \propto \sqrt{pressure}$)).

[2] Pressure to temperature

Pressure to temperature [2] is used in compressor applications to provide temperature feedback using a pressure sensor. The temperature of the refrigerant is calculated using the following formula:

$$Temperature = \frac{A2}{(\ln(Pe + 1) - A1)} - A3,$$

where A1, A2 and A3 are refrigerant-specific constants. The refrigerant must be selected in par. 20-30 [Refrigerant](#). Par. 20-21 [Setpoint 1](#) through par. 20-23 [Setpoint 3](#) allow the values of A1, A2 and A3 to be entered for a refrigerant that is not listed in par. 20-30 [Refrigerant](#).

20-02 Feedback 1 Source Unit

Option:

Function:

This parameter determines the unit that is used for this Feedback Source, prior to applying the feedback conversion of par. 20-01 [Feedback 1 Conversion](#). This unit is not used by the PID Controller.

[0] *

[1] %

[5] PPM

[10] min

[11] RPM

[12] PULSE/s

[20] liter / sec.

[21] liter / min

[22] liter / hr.

[23] m³ / sec.

[24] m³/min

[25] m³ / hr.

[30] kg / sec.

[31] kg/min

How to program the Frequency Converter

[32]	kg / hr.
[33]	ton / min
[34]	ton / hr.
[40]	m / sec.
[41]	m/min
[45]	m
[60]	°C
[70]	mbar
[71]	bar
[72]	Pa
[73]	kPa
[74]	m WG
[75]	mm Hg
[80]	kW
[120]	GPM
[121]	gal / sec.
[122]	gal/min
[123]	gal / hr.
[124]	CFM
[125]	ft ³ /s
[126]	ft ³ /min
[127]	ft ³ /h
[130]	lbs / sec.
[131]	lbs / min.
[132]	lbs / hr.
[140]	ft/s
[141]	ft/min
[145]	ft
[160]	°F
[170]	psi
[171]	lb/in ²
[172]	in. wtr. gage
[173]	ft WG
[174]	in Hg
[180]	HP

This parameter is only available when using pressure to temperature feedback conversion.
If the choice Linear [0] is selected in par. 20-01 [Feedback 1 Conversion](#), then the setting of any choice in par. 20-02 [Feedback 1 Source Unit](#) does not matter as conversion will be one-to-one.

20-03 Feedback 2 Source

Option:

Function:

See par. 20-00 [Feedback 1 Source](#) for details.

- [0] * No function
- [1] Analog input 53
- [2] Analog input 54
- [3] Pulse input 29
- [4] Pulse input 33
- [7] Analog input X30/11
- [8] Analog input X30/12
- [9] Analog Input X42/1
- [10] Analog Input X42/3
- [11] Analog Input X42/5
- [12] Analog Input X49/1
- [13] Analog Input X49/3
- [14] Analog Input X49/5
- [100] Bus feedback 1
- [101] Bus feedback 2
- [102] Bus feedback 3

20-04 Feedback 2 Conversion

Option:

Function:

See par. 20-01 [Feedback 1 Conversion](#) for details.

- [0] * Linear
- [1] Square root
- [2] Pressure to temperature

20-07 Feedback 3 Conversion

Option:

Function:

See par. 20-01 [Feedback 1 Conversion](#) for details.

- [0] * Linear
- [1] Square root
- [2] Pressure to temperature

20-12 Reference/Feedback Unit

Option:

Function:

See par. 20-02 [Feedback 1 Source Unit](#) for details.

20-13 Minimum Reference/Feedb.

Range:

Function:

0.000 [Application dependant]
Proc-
essCtrlU-
nit*

Enter the desired minimum value for the remote reference when operating with par. 1-00 [Configuration Mode](#) set for Closed Loop [3] operation. Units are set in par. 20-12 [Reference/Feedback Unit](#).

Minimum feedback will be -200% of either the value set in par. 20-13 [Minimum Reference/Feedb.](#) or in par. 20-14 [Maximum Reference/Feedb.](#), which ever numeric value is the highest.

If operating with par. 1-00 [Configuration Mode](#) set for Open Loop [0], par. 3-02 [Minimum Reference](#) must be used.

20-14 Maximum Reference/Feedb.

Range:	Function:
100.000 [Application dependant] Proc- essCtrlU- nit*	Enter the maximum reference/feedback for closed loop operation. The setting determines the highest value obtainable by summing all reference sources for closed loop operation. The setting determines 100% feedback in open and closed loop (total feedback range: -200% to +200%).

If operating with par. 1-00 [Configuration Mode](#) set for Open Loop [0], par. 3-03 [Maximum Reference](#) must be used.

The dynamics of the PID controller will depend on the value set in this parameter. Please see also par. 20-93 [PID Proportional Gain](#).

Par. 20-13 and par. 20-14 also determine the feedback range when using feedback for display readout with par. 1-00 [Configuration Mode](#) set for Open Loop [0]. Same condition as above.

20-20 Feedback Function

Option:	Function:
	This parameter determines how the three possible feedbacks will be used to control the output frequency of the frequency converter.
[0] Sum	<p><i>Sum</i> [0] sets up the PID Controller to use the sum of Feedback 1, Feedback 2 and Feedback 3 as the feedback.</p> <p>Any unused feedbacks must be set to No Function in par. 20-00 Feedback 1 Source, par. 20-03 Feedback 2 Source, or par. 20-06 Feedback 3 Source.</p> <p>The sum of Setpoint 1 and any other references that are enabled (see par. group 3-1*) will be used as the PID Controller's set-point reference.</p>
[1] Difference	<p><i>Difference</i> [1] sets up the PID controller to use the difference between Feedback 1 and Feedback 2 as the feedback. Feedback 3 will not be used with this selection. Only Setpoint 1 will be used. The sum of Setpoint 1 and any other references that are enabled (see par. group 3-1*) will be used as the PID controller's set-point reference.</p>
[2] Average	<p><i>Average</i> [2] sets up the PID Controller to use the average of Feedback 1, Feedback 2 and Feedback 3 as the feedback.</p> <p>Any unused feedbacks must be set to No Function in par. 20-00 Feedback 1 Source, par. 20-03 Feedback 2 Source, or par. 20-06 Feedback 3 Source. The sum of Setpoint 1 and any other references that are enabled (see par. group 3-1*) will be used as the PID Controller's set-point reference.</p>
[3] * Minimum	<p><i>Minimum</i> [3] sets up the PID Controller to compare Feedback 1, Feedback 2 and Feedback 3 and use the lowest value as the feedback.</p> <p>Any unused feedbacks must be set to No Function in par. 20-00 Feedback 1 Source, par. 20-03 Feedback 2 Source, or par. 20-06 Feedback 3 Source. Only setpoint 1 will be used. The sum of Setpoint 1 and any other references that are enabled (see par. group 3-1*) will be used as the PID Controller's setpoint reference.</p>
[4] Maximum	<p><i>Maximum</i> [4] sets up the PID Controller to compare Feedback 1, Feedback 2 and Feedback 3 and use the highest value as the feedback.</p>

Any unused feedbacks must be set to **No Function** in par. 20-00 [Feedback 1 Source](#), par. 20-03 [Feedback 2 Source](#), or par. 20-06 [Feedback 3 Source](#).

Only Setpoint 1 will be used. The sum of Setpoint 1 and any other references that are enabled (see par. group 3-1*) will be used as the PID Controller's setpoint reference.

[5] Multi Setpoint Min *Multi-setpoint minimum* [5] sets up the PID Controller to calculate the difference between Feedback 1 and Setpoint 1, Feedback 2 and Setpoint 2, and Feedback 3 and Setpoint 3. It will use the feedback/setpoint pair in which the feedback is the farthest below its corresponding setpoint reference. If all feedback signals are above their corresponding setpoints, the PID Controller will use the feedback/setpoint pair in which the difference between the feedback and setpoint is the least.

If only two feedback signals are used, the feedback that is not to be used must be set to **No Function** in par. 20-00 [Feedback 1 Source](#), par. 20-03 [Feedback 2 Source](#) or par. 20-06 [Feedback 3 Source](#). Note that each setpoint reference will be the sum of its respective parameter value (par. 20-21 [Setpoint 1](#), par. 20-22 [Setpoint 2](#) and par. 20-23 [Setpoint 3](#)) and any other references that are enabled (see par. group 3-1*).

[6] Multi Setpoint Max *Multi-setpoint maximum* [6] sets up the PID Controller to calculate the difference between Feedback 1 and Setpoint 1, Feedback 2 and Setpoint 2, and Feedback 3 and Setpoint 3. It will use the feedback/setpoint pair in which the feedback is farthest above its corresponding setpoint reference. If all feedback signals are below their corresponding setpoints, the PID Controller will use the feedback/setpoint pair in which the difference between the feedback and the setpoint reference is the least.

If only two feedback signals are used, the feedback that is not to be used must be set to **No Function** in par. 20-00 [Feedback 1 Source](#), par. 20-03 [Feedback 2 Source](#) or par. 20-06 [Feedback 3 Source](#). Note that each setpoint reference will be the sum of its respective parameter value (par. 20-21 [Setpoint 1](#), par. 20-22 [Setpoint 2](#) and par. 20-23 [Setpoint 3](#)) and any other references that are enabled (see parameter group 3-1*).

Any unused feedback must be set to "No function" in its Feedback Source parameter: Par. 20-00 [Feedback 1 Source](#), par. 20-03 [Feedback 2 Source](#) or par. 20-06 [Feedback 3 Source](#).

The feedback resulting from the function selected in par. 20-20 [Feedback Function](#) will be used by the PID Controller to control the output frequency of the frequency converter. This feedback can also be shown on the frequency converter's display, be used to control a frequency converter's analog output, and be transmitted over various serial communication protocols.

The frequency converter can be configured to handle multi zone applications. Two different multi zone applications are supported:

- Multi zone, single setpoint
- Multi zone, multi setpoint

The difference between the two is illustrated by the following examples:

Example 1 – Multi zone, single setpoint

In an office building, a VAV (variable air volume) TR200 system must ensure a minimum pressure at selected VAV boxes. Due to the varying pressure losses in each duct, the pressure at each VAV box cannot be assumed to be the same. The minimum pressure required is the same for all VAV boxes. This control method can be set up by setting par. 20-20 [Feedback Function](#) to option [3], Minimum, and entering the desired pressure in par. 20-21 [Setpoint 1](#). The PID Controller will increase the speed of the fan if any one feedback is below the setpoint and decrease the speed of the fan if all feedbacks are above the setpoint.

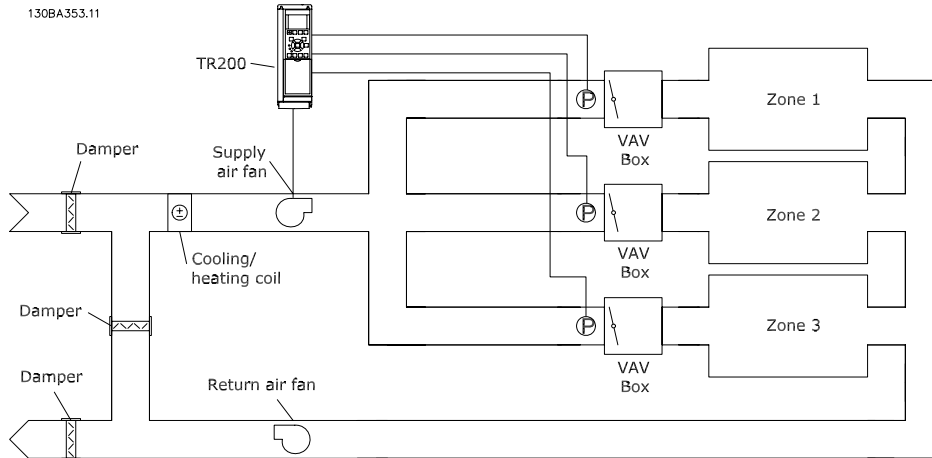

Example 2 – Multi zone, multi setpoint

The previous example can be used to illustrate the use of multi zone, multi setpoint control. If the zones require different pressures for each VAV box, each setpoint may be specified in par. 20-21 [Setpoint 1](#), par. 20-22 [Setpoint 2](#) and par. 20-23 [Setpoint 3](#). By selecting *Multi setpoint minimum*, [5], in par. 20-20 [Feedback Function](#), the PID Controller will increase the speed of the fan if any one of the feedbacks is below its setpoint and decrease the speed of the fan if all feedbacks are above their individual setpoints.

20-21 Setpoint 1

Range:

0.000 [-999999.999 - 999999.999]
Proc- ProcessCtrlUnit]
essCtrlU-
nit*

Function:

Setpoint 1 is used in Closed Loop Mode to enter a setpoint reference that is used by the frequency converter's PID Controller. See the description of par. 20-20 [Feedback Function](#).

Setpoint reference entered here is added to any other references that are enabled (see par. group 3-1*).

20-22 Setpoint 2

Range:

0.000 [-999999.999 - 999999.999]
Proc- ProcessCtrlUnit]
essCtrlU-
nit*

Function:

Setpoint 2 is used in Closed Loop Mode to enter a setpoint reference that may be used by the frequency converter's PID Controller. See the description of *Feedback Function*, par. 20-20 [Feedback Function](#).

The set-point reference entered here is added to any other references that are enabled (see par. group 3-1*).

20-70 Closed-loop Type

Option:

Function:

This parameter defines the application response. The default mode should be sufficient for most applications. If the application response speed is known, it can be selected here. This will decrease the time needed for carrying out PID autotuning. The setting has no impact on the value of the tuned parameters and is used only for the autotuning sequence.

[0] * Auto

[1] Fast Pressure

[2] Slow Pressure

[3] Fast Temperature

[4] Slow Temperature

20-71 Tuning Mode

Option:

Function:

[0] * Normal

Normal setting of this parameter will be suitable for pressure control in fan systems.

[1] Fast

Fast setting would generally be used in pumping systems, where a faster control response is desirable.

20-72 PID Output Change

Range:

Function:

0.10* [0.01 - 0.50]

This parameter sets the magnitude of step change during autotuning. The value is a percentage of full speed. I.e. if maximum output frequency in par. 4-13 [Motor Speed High Limit \[RPM\]](#)/par. 4-14 [Motor Speed High Limit \[Hz\]](#) is set to 50Hz, 0.10 is 10% of 50Hz, which is 5Hz. This parameter should be set to a value resulting in feedback changes of between 10% and 20% for best tuning accuracy.

20-73 Minimum Feedback Level

Range:

Function:

-999999. [Application dependant]
000
Proc-
essCtrlU-
nit*

The minimum allowable feedback level should be entered here in User units as defined in par. 20-12 [Reference/Feedback Unit](#). If the level falls below par. 20-73 [Minimum Feedback Level](#), autotuning is aborted and an error message will appear on the keypad.

20-74 Maximum Feedback Level

Range:

Function:

999999. [Application dependant]
000
Proc-
essCtrlU-
nit*

The maximum allowable feedback level should be entered here in User units as defined in par. 20-12 [Reference/Feedback Unit](#). If the level rises above par. 20-74 [Maximum Feedback Level](#), autotuning is aborted and an error message will appear on the keypad.

20-79 PID Auto Tuning

Option:

Function:

This parameter starts the PID autotuning sequence. Once the autotuning has successfully completed and the settings have been accepted or rejected by the user, by pressing [OK] or [Cancel] buttons on the keypad at the end of tuning, this parameter is reset to [0] Disabled.

[0] * Disabled

[1] Enabled

20-81 PID Normal/ Inverse Control

Option:

Function:

[0] * Normal

Normal [0] causes the frequency converter's output frequency to decrease when the feedback is greater than the setpoint reference. This is common for pressure-controlled supply fan and pump applications.

[1] Inverse

Inverse [1] causes the frequency converter's output frequency to increase when the feedback is greater than the setpoint reference. This is common for temperature-controlled cooling applications, such as cooling towers.

20-82 PID Start Speed [RPM]

Range:

Function:

Application dependent*

When the frequency converter is first started, it initially ramps up to this output speed in Open Loop Mode, following the active Ramp Up Time. When the output speed programd here is reached, the frequency converter will automatically switch to Closed Loop Mode and the PID Controller will begin to function. This is useful in applications in which the driven load must first quickly accelerate to a minimum speed when it is started.

This parameter will only be visible if par. 0-02 [Motor Speed Unit](#) is set to [0], RPM.

20-83 PID Start Speed [Hz]

Range:

Function:

Application dependent*

When the frequency converter is first started, it initially ramps up to this output frequency in Open Loop Mode, following the active Ramp Up Time. When the output frequency programd here is reached, the frequency converter will automatically switch to Closed Loop Mode and the PID Controller will begin to function. This is useful in applications in which the driven load must first quickly accelerate to a minimum speed when it is started.

This parameter will only be visible if par. 0-02 [Motor Speed Unit](#) is set to [1], Hz.

20-93 PID Proportional Gain

Range:

Function:

0.50* [0.00 - 10.00]

If (Error x Gain) jumps with a value equal to what is set in par. 20-14 [Maximum Reference/Feedb.](#) the PID controller will try to change the output speed equal to what is set in par. 4-13 [Motor Speed High Limit \[RPM\]](#) / par. 4-14 [Motor Speed High Limit \[Hz\]](#) but in practice of course limited by this setting.

The proportional band (error causing output to change from 0-100%) can be calculated by means of the formula:

$$\left(\frac{1}{\text{Proportional Gain}} \right) \times (\text{Max Reference})$$

Always set the desired for par. 20-14 [Maximum Reference/Feedb.](#) before setting the values for the PID controller in parameter group 20-9*.

20-94 PID Integral Time

Range:

20.00 s* [0.01 - 10000.00 s]

Function:

Over time, the integrator accumulates a contribution to the output from the PID controller as long as there is a deviation between the Reference/Setpoint and feedback signals. The contribution is proportional to the size of the deviation. This ensures that the deviation (error) approaches zero.

Quick response on any deviation is obtained when the integral time is set to a low value. Setting it too low, however, may cause the control to become unstable.

The value set, is the time needed for the integrator to add the same contribution as the proportional part for a certain deviation.

If the value is set to 10,000, the controller will act as a pure proportional controller with a P-band based on the value set in par. 20-93 [PID Proportional Gain](#). When no deviation is present, the output from the proportional controller will be 0.

22-22 Low Speed Detection

Option:

[0] * Disabled

[1] Enabled

Function:

Select Enabled for detecting when the motor operates with a speed as set in par. 4-11 [Motor Speed Low Limit \[RPM\]](#) or par. 4-12 [Motor Speed Low Limit \[Hz\]](#).

22-23 No-Flow Function

Common actions for Low Power Detection and Low Speed Detection (Individual selections not possible).

Option:

[0] * OFF

[1] Sleep Mode

[2] Warning

[3] Alarm

Function:

The drive will enter Sleep Mode and stop when a No Flow condition is detected. See parameter group 22-4* for programming options for Sleep Mode.

The drive will continue to run, but activate a No-Flow Warning [W92]. A drive digital output or a serial communication bus can communicate a warning to other equipment.

The drive will stop running and activate a No-Flow Alarm [A 92]. A drive digital output or a serial communication bus can communicate an alarm to other equipment.

Do not set par. 14-20 [Reset Mode](#), to [13] Infinite auto reset, when par. 22-23 [No-Flow Function](#) is set to [3] Alarm. Doing so will cause the drive to continuously cycle between running and stopping when a No Flow condition is detected.

If the drive is equipped with a constant speed bypass with an automatic bypass function that starts the bypass if the drive experiences a persistent alarm condition, be sure to disable the bypass's automatic bypass function, if [3] Alarm is selected as the No-Flow Function.

22-24 No-Flow Delay

Range:

10 s* [1 - 600 s]

Function:

Set the time Low Power/Low Speed must stay detected to activate signal for actions. If detection disappears before run out of the timer, the timer will be reset.

22-40 Minimum Run Time

Range:	Function:
10 s* [0 - 600 s]	Set the desired minimum running time for the motor after a start command (digital input or Bus) before entering Sleep Mode.

22-41 Minimum Sleep Time

Range:	Function:
10 s* [0 - 600 s]	Set the desired Minimum Time for staying in Sleep Mode. This will override any wake up conditions.

22-42 Wake-up Speed [RPM]

Range:	Function:
Application dependent*	To be used if par. 0-02 Motor Speed Unit has been set for RPM (parameter not visible if Hz selected). Only to be used if par. 1-00 Configuration Mode is set for Open Loop and speed reference is applied by an external controller. Set the reference speed at which the Sleep Mode should be cancelled.

22-43 Wake-up Speed [Hz]

Range:	Function:
Application dependent*	To be used if par. 0-02 Motor Speed Unit , has been set for Hz (parameter not visible if RPM selected). Only to be used if par. 1-00 Configuration Mode , is set for Open Loop and speed reference is applied by an external controller controlling the pressure. Set the reference speed at which the Sleep Mode should be cancelled.

22-44 Wake-up Ref./FB Difference

Range:	Function:
10 %* [0 - 100 %]	Only to be used if par. 1-00 Configuration Mode is set for Closed Loop and the integrated PI controller is used for controlling the pressure. Set the pressure drop allowed in percentage of set point for the pressure (Pset) before cancelling the Sleep Mode.

If used in application where the integrated PI controller is set for inverse control (e.g. cooling tower applications) in par. 20-71 [Tuning Mode](#), the value set in par. 22-44 [Wake-up Ref./FB Difference](#) will automatically be added.

22-45 Setpoint Boost

Range:	Function:
0 %* [-100 - 100 %]	Only to be used if par. 1-00 Configuration Mode , is set for Closed Loop and the integrated PI controller is used. In systems with e.g. constant pressure control, it is advantageous to increase the system pressure before the motor is stopped. This will extend the time in which the motor is stopped and help to avoid frequent start/stop. Set the desired over pressure/temperature in percentage of set point for the pressure (Pset)/temperature before entering the Sleep Mode. If setting for 5%, the boost pressure will be Pset*1.05. The negative values can be used for e.g. cooling tower control where a negative change is needed.

22-46 Maximum Boost Time

Range:

60 s* [0 - 600 s]

Function:

Only to be used if par. 1-00 [Configuration Mode](#) is set for Closed Loop and the integrated PI controller is used for controlling the pressure. Set the maximum time for which boost mode will be allowed. If the set time is exceeded, Sleep Mode will be entered, not waiting for the set boost pressure to be reached.

22-60 Broken Belt Function

Selects the action to be performed if the Broken Belt condition is detected

Option:

[0] * OFF

[1] Warning

[2] Trip

Function:

The drive will continue to run, but activate a Broken Belt Warning [W95]. A drive digital output or a serial communication bus can communicate a warning to other equipment.

The drive will stop running and activate a Broken Belt alarm [A 95]. A drive digital output or a serial communication bus can communicate an alarm to other equipment.

Do not set par. 14-20 [Reset Mode](#), to [13] Infinite auto reset, when par. 22-60 [Broken Belt Function](#) is set to [2] Trip. Doing so will cause the drive to continuously cycle between running and stopping when a broken belt condition is detected.

If the drive is equipped with a constant speed bypass with an automatic bypass function that starts the bypass if the drive experiences a persistent alarm condition, be sure to disable the bypass's automatic bypass function, if [2] Trip is selected as the Broken Belt Function.

22-61 Broken Belt Torque

Range:

10 %* [0 - 100 %]

Function:

Sets the broken belt torque as a percentage of the rated motor torque.

22-62 Broken Belt Delay

Range:

10 s [0 - 600 s]

Function:

Sets the time for which the Broken Belt conditions must be active before carrying out the action selected in par. 22-60 [Broken Belt Function](#).

22-75 Short Cycle Protection

Option:

[0] * Disabled

[1] Enabled

Function:

Timer set in par. 22-76 [Interval between Starts](#) is disabled.

Timer set in par. 22-76 [Interval between Starts](#) is enabled.

22-76 Interval between Starts

Range:

Application dependent* [Application dependant]

Function:

Sets the time desired as minimum time between two starts. Any normal start command (Start/Jog/Freeze) will be disregarded until the timer has expired.

22-77 Minimum Run Time

Range:

0 s* [Application dependant]

Function:

Sets the time desired as minimum run time after a normal start command (Start/Jog/Freeze). Any normal stop command will be disregarded until the set time has expired. The timer will start counting following a normal start command (Start/Jog/Freeze).

The timer will be overridden by a Coast (Inverse) or an External Interlock command.

Does not work in cascade mode.

Parameter Set-Up

Group	Title	Function
0-	Operation and Display	Parameters used to program the fundamental functions of the frequency converter and the keypad including: selection of language; selection of which variables are displayed at each position in the display (e.g. static duct pressure or condenser water return temperature can be displayed with the setpoint in small digits in the top row and feedback in large digits in the centre of the display); enabling/disabling of the keypad keys/buttons; passwords for the keypad; upload and download of commissioned parameters to/from the keypad and setting the built in clock.
1-	Load / Motor	Parameters used to configure the frequency converter for the specific application and motor including: open or closed loop operation; type of application such as compressor, fan or centrifugal pump; motor nameplate data; auto-tuning of the drive to the motor for optimum performance; flying start (typically used for fan applications) and motor thermal protection.
2-	Brakes	Parameters used to configure braking functions of the frequency converter which although not common in many HVAC applications, can be useful on special fan applications. Parameters including: DC braking; dynamic/resistor braking and over voltage control (which provides automatic adjustment of the deceleration rate (auto-ramping) to avoid tripping when decelerating large inertia fans)
3-	Reference / Ramps	Parameters used to program the minimum and maximum reference limits of speed (RPM/Hz) in open loop or in actual units when operating in closed loop); digital/preset references; jog speed; definition of the source of each reference (e.g. which analog input the reference signal is connected to); ramp up and down times and digital potentiometer settings.
4-	Limits / Warnings	Parameters used to program limits and warnings of operation including: allowable motor direction; minimum and maximum motor speeds (e.g. in pump applications it is typical to program a minimum speed to approx 30-40% to ensure pump seals are adequately lubricated at all times, avoid cavitation and ensure adequate head is produced at all times to create flow); torque and current limits to protect the pump, fan or compressor driven by the motor; warnings for low/high current, speed, reference, and feedback; missing motor phase protection; speed bypass frequencies including semi-automatic setup of these frequencies (e.g. to avoid resonance conditions on cooling tower and other fans).
5-	Digital In / Out	Parameters used to program the functions of all digital inputs, digital outputs, relay outputs, pulse inputs and pulse outputs for terminals on the control card and all option cards.
6-	Analog In / Out	Parameters used to program the functions associated with all analog inputs and analog outputs for the terminals on the control card and General Purpose I/O option (MCB101) including: analog input live zero timeout function (which for example can be used to command a cooling tower fan to operate at full speed if the condenser water return sensor fails); scaling of the analog input signals (for example to match the analog input to the mA and pressure range of a static duct pressure sensor); filter time constant to filter out electrical noise on the analog signal which can sometimes occur when long cables are installed; function and scaling of the analog outputs (for example to provide an analog output representing motor current or kW to an analog input of a DDC controller) and to configure the analog outputs to be controlled by the BMS via a high level interface (HLI) (e.g. to control a chilled water valve) including ability to define a default value of these outputs in the event of the HLI failing.

Table 6. 2: Parameter Groups

Group	Title	Function
8-	Communication and Options	Parameters used for configuring and monitoring functions associated with the serial communications / high level interface to the frequency converter
11-	LonWorks	Parameters only applicable when a Lonworks option is installed.
13-	Smart Logic Controller	Parameters used to configure the built in Smart Logic Controller (SLC) which can be used for simple functions such as comparators (e.g. if running above xHz, activate output relay), timers (e.g. when a start signal is applied, first activate output relay to open supply air damper and wait x seconds before ramping up) or a more complex sequence of user defined actions executed by the SLC when the associated user defined event is evaluated as TRUE by the SLC. (For example, initiate an economiser mode in a simple AHU cooling application control scheme where there is no BMS. For such an application the SLC can monitor the outside air relative humidity and if it is below a defined value, the supply air temperature setpoint could be automatically increased. With the frequency converter monitoring the outside air relative humidity and supply air temperature via it's analog inputs and controlling the chilled water valve via one of the extended PI(D) loops and an analog output, it would then modulate that valve to maintain a higher supply air temperature). The SLC can often replace the need for other external control equipment.
14-	Special Functions	Parameters used to configure special functions of the frequency converter including: setting of the switching frequency to reduce audible noise from the motor (sometimes required for fan applications); kinetic back-up function (especially useful for critical applications in semi-conductor installations where performance under mains dip/mains loss is important); mains imbalance protection; automatic reset (to avoid the need for a manual reset of Alarms); energy optimization parameters (which typically do not need changing but enable fine tuning of this automatic function (if necessary) ensuring the frequency converter and motor combination operate at their optimum efficiency at full and partial load conditions) and auto-derating functions (which enable the frequency converter to continue operation at reduced performance under extreme operating conditions ensuring maximum up time).
15-	FC Information	Parameters providing operating data and other drive information including: operating and running hour counters; kWh counter; resetting of the running and kWh counters; alarm/fault log (where the past 10 alarms are logged along with any associated value and time) and drive and option card identification parameters such as code number and software version.
16-	Data Readouts	Read only parameters which display the status/value of many operating variables which can be displayed on the keypad or viewed in this parameter group. These parameters can be particularly useful during commissioning when interfacing with a BMS via a high level interface.
18-	Info & Readouts	Read only parameters which display the last 10 preventative maintenance log items, actions and time and the value of analog inputs and outputs on the Analog I/O option card which can be particularly useful during commissioning when interfacing with a BMS via a high level interface.

Table 6. 3: Parameter Groups

Group	Title	Function
20-	FC Closed Loop	Parameters used to configure the closed loop PI(D) controller which controls the speed of the pump, fan or compressor in closed loop mode including: defining where each of the 3 possible feedback signals come from (e.g. which analog input or the BMS HLI); conversion factor for each of the feedback signals (e.g. where a pressure signal is used for indication of flow in an AHU or converting from pressure to temperature in a compressor application); engineering unit for the reference and feedback (e.g. Pa, kPa, m Wg, in Wg, bar, m3/s, m3/h, °C, °F etc); the function (e.g. sum, difference, average, minimum or maximum) used to calculate the resulting feedback for single zone applications or the control philosophy for multi-zone applications; programming of the setpoint(s) and manual or auto-tuning of the PI(D) loop.
21-	Extended Closed Loop	Parameters used to configure the 3 extended closed loop PI(D) controllers which for example can be used to control external actuators (e.g. chilled water valve to maintain supply air temperature in a VAV system) including: engineering unit for the reference and feedback of each controller (e.g. °C, °F etc); defining the range of the reference/setpoint for each controller; defining where each of the references/setpoints and feedback signals come from (e.g. which analog input or the BMS HLI); programming of the setpoint and manual or auto-tuning of the each of the PI(D) controllers.
22-	Application Functions	Parameters used to monitor, protect and control pumps, fans and compressors including: no flow detection and protection of pumps (including auto-setup of this function); dry pump protection; end of curve detection and protection of pumps; sleep mode (especially useful for cooling tower and booster pump sets); broken belt detection (typically used for fan applications to detect no air flow instead of using a Δp switch installed across the fan); short cycle protection of compressors and pump flow compensation of setpoint (especially useful for secondary chilled water pump applications where the Δp sensor has been installed close to the pump and not across the furthest most significant load(s) in the system; using this function can compensate for the sensor installation and help to realise the maximum energy savings).
23-	Time Based Functions	Time based parameters including: those used to initiate daily or weekly actions based on the built in real time clock (e.g. change of setpoint for night set back mode or start/stop of the pump/fan/compressor start/stop of a external equipment); preventative maintenance functions which can be based on running or operating hour time intervals or on specific dates and times; energy log (especially useful in retrofit applications or where information of the actual historical load (kW) on the pump/fan/compressor is of interest); trending (especially useful in retrofit or other applications where there is an interest to log operating power, current, frequency or speed of the pump/fan/compressor for analysis and a payback counter).
24-	Application Functions 2	Parameters used to set-up Fire Mode and/or to control a bypass contactor/ starter if designed into the system.
25-	Cascade Controller	Parameters used to configure and monitor the built in pump cascade controller (typically used for pump booster sets).

Table 6. 4: Parameter Groups

Parameter descriptions and selections are displayed on the graphic keypad. (See relevant section for details.) Access the parameters by pressing the [Quick Menu] or [Main Menu] button on the control panel. The Quick Menu is used primarily for commissioning the unit at start-up by providing the parameters necessary to start operation. The Main Menu provides access to all parameters for detailed application programming.

All digital input/output and analog input/output terminals are multifunctional. All terminals have factory default functions suitable for the majority of HVAC applications but if other special functions are required, they must be programmed as explained in parameter group 5 or 6.

Main Menu Mode

The keypad provides access to the main menu mode. Select the Main Menu mode by pressing the [Main Menu] key. Illustration 6.2 shows the resulting read-out, which appears on the display of the GLCP keypad.

Lines 2 through 5 on the display show a list of parameter groups which can be chosen by toggling the up and down buttons.

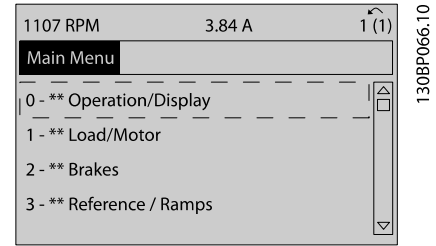

Figure 6. 9: Display example.

Each parameter has a name and number which remain the same regardless of the programming mode. In the Main Menu mode, the parameters are divided into groups. The first digit of the parameter number (from the left) indicates the parameter group number.

All parameters can be changed in the Main Menu. The configuration of the unit (par. 1-00 [Configuration Mode](#)) will determine other parameters available for programming. For example, selecting Closed Loop enables additional parameters related to closed loop operation. Option cards added to the unit enable additional parameters associated with the option device.

Changing Data

1. Press [Quick Menu] or [Main Menu] key.
2. Use [▲] and [▼] keys keys to find parameter group to edit.
3. Press [OK] key.
4. Use [▲] and [▼] keys to find parameter to edit.
5. Press [OK] key.
6. Use [▲] and [▼] keys to select correct parameter setting. Or, to move to digits within a number, use keys. Cursor indicates digit selected to change. [▲] key increases the value, [▼] key decreases the value.
7. Press [Cancel] key to disregard change, or press [OK] key to accept change and enter new setting.

Changing a Text Value

If the selected parameter is a text value, change the text value by means of the up/down navigation keys. The up key increases the value, and the down key decreases the value. Place the cursor on the value to be saved and press [OK].

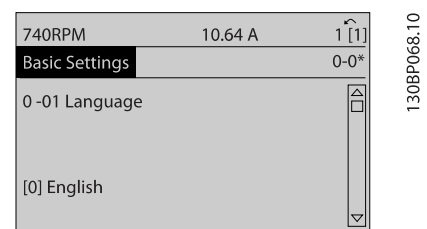

Figure 6. 10: Display example.

Changing a Group of Numeric Data Values

If the chosen parameter represents a numeric data value, change the chosen data value by means of the [◀] and [▶] navigation keys as well as the up/down [▲] [▼] navigation keys. Use the [◀] and [▶] navigation keys to move the cursor horizontally.

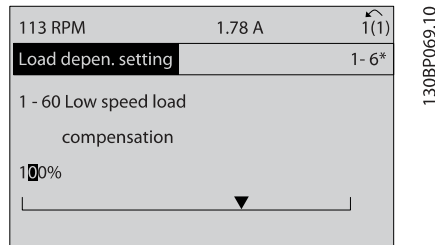

Figure 6.12: Display example.

Use the up/down navigation keys to change the data value. The up key enlarges the data value, and the down key reduces the data value. Place the cursor on the value to be saved and press [OK].

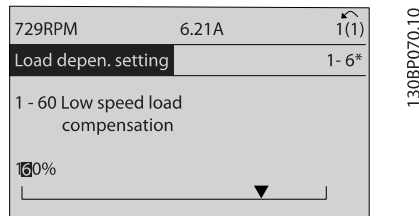

Figure 6.13: Display example.

Changing of Data Value, Step-by-Step

Certain parameters can be changed step by step or infinitely variably. This applies to par. 1-20 [Motor Power \[kW\]](#), par. 1-22 [Motor Voltage](#) and par. 1-23 [Motor Frequency](#).

The parameters are changed both as a group of numeric data values and as numeric data values infinitely variably.

Read-out and Programming of Indexed Parameters

Parameters are indexed when placed in a rolling stack.

Par. 15-30 [Alarm Log: Error Code](#) to par. 15-32 [Alarm Log: Time](#) contain a fault log which can be read out. Choose a parameter, press [OK], and use the up/down navigation keys to scroll through the value log.

Use par. 3-10 [Preset Reference](#) as another example:

Choose the parameter, press [OK], and use the up/down navigation keys to scroll through the indexed values. To change the parameter value, select the indexed value and press [OK]. Change the value by using the up/down keys. Press [OK] to accept the new setting. Press [Cancel] to abort. Press [Back] to leave the parameter.

Parameter Lists TR200

Default settings

Changes during operation:

“TRUE” means that the parameter can be changed while the frequency converter is in operation and “FALSE” means that the frequency converter must be stopped before a change can be made.

4-Set-up:

'All set-up': the parameter can be set individually in each of the four set-ups, i. e. one single parameter can have four different data values.

'1 set-up': data value will be the same in all set-ups.

SR:

Size related

N/A:

No default value available.

Conversion index:

This number refers to a conversion figure used when writing or reading by means of a frequency converter.

Conv. index	100	67	6	5	4	3	2	1	0	-1	-2	-3	-4	-5	-6
Conv. factor	1	1/60	10000 00	10000 0	1000 0	1000	100	10	1	0.1	0.01	0.00 1	0.000 1	0.000 01	0.00000 1

Data type	Description	Type
2	Integer 8	Int8
3	Integer 16	Int16
4	Integer 32	Int32
5	Unsigned 8	UInt8
6	Unsigned 16	UInt16
7	Unsigned 32	UInt32
9	Visible String	VisStr
33	Normalized value 2 bytes	N2
35	Bit sequence of 16 boolean variables	V2
54	Time difference w/o date	TimD

0-** Operation and Display

Par. No. #	Parameter description	Default value	4-set-up	Change during operation	Conversion index	Type
0-0* Basic Settings						
0-01	Language	[0] English	1 set-up	TRUE	-	Uint8
0-02	Motor Speed Unit	[1] Hz	2 set-ups	FALSE	-	Uint8
0-03	Regional Settings	[0] International	2 set-ups	FALSE	-	Uint8
0-04	Operating State at Power-up	[0] Resume	All set-ups	TRUE	-	Uint8
0-05	Local Mode Unit	[0] As Motor Speed Unit	2 set-ups	FALSE	-	Uint8
0-1* Set-up Operations						
0-10	Active Set-up	[1] Set-up 1	1 set-up	TRUE	-	Uint8
0-11	Programming Set-up	[9] Active Set-up	All set-ups	TRUE	-	Uint8
0-12	This Set-up Linked to	[0] Not linked	All set-ups	FALSE	-	Uint8
0-13	Readout: Linked Set-ups	0 N/A	All set-ups	FALSE	0	Uint16
0-14	Readout: Prog. Set-ups / Channel	0 N/A	All set-ups	TRUE	0	Int32
0-2* LCP Display						
0-20	Display Line 1.1 Small	1602	All set-ups	TRUE	-	Uint16
0-21	Display Line 1.2 Small	1614	All set-ups	TRUE	-	Uint16
0-22	Display Line 1.3 Small	1610	All set-ups	TRUE	-	Uint16
0-23	Display Line 2 Large	1613	All set-ups	TRUE	-	Uint16
0-24	Display Line 3 Large	1502	All set-ups	TRUE	-	Uint16
0-25	My Personal Menu	ExpressionLimit	1 set-up	TRUE	0	Uint16
0-3* LCP Cust. Readout						
0-30	Custom Readout Unit	[1] %	All set-ups	TRUE	-	Uint8
0-31	Custom Readout Min Value	ExpressionLimit	All set-ups	TRUE	-2	Int32
0-32	Custom Readout Max Value	100.00 CustomReadoutUnit	All set-ups	TRUE	-2	Int32
0-37	Display Text 1	ExpressionLimit	1 set-up	TRUE	0	VisStr[25]
0-38	Display Text 2	ExpressionLimit	1 set-up	TRUE	0	VisStr[25]
0-39	Display Text 3	ExpressionLimit	1 set-up	TRUE	0	VisStr[25]

How to program the Frequency Converter

Par. No. #	Parameter description	Default value	4-set-up	Change during operation	Conversion index	Type
0-4* LCP Keypad						
0-40	[Hand on] Key on LCP	[1] Enabled	All set-ups	TRUE	-	UInt8
0-41	[Off] Key on LCP	[1] Enabled	All set-ups	TRUE	-	UInt8
0-42	[Auto on] Key on LCP	[1] Enabled	All set-ups	TRUE	-	UInt8
0-43	[Reset] Key on LCP	[1] Enabled	All set-ups	TRUE	-	UInt8
0-44	[Off/Reset] Key on LCP	[1] Enabled	All set-ups	TRUE	-	UInt8
0-45	[Drive Bypass] Key on LCP	[1] Enabled	All set-ups	TRUE	-	UInt8
0-5* Copy/Save						
0-50	LCP Copy	[0] No copy	All set-ups	FALSE	-	UInt8
0-51	Set-up Copy	[0] No copy	All set-ups	FALSE	-	UInt8
0-6* Password						
0-60	Main Menu Password	100 N/A	1 set-up	TRUE	0	Int16
0-61	Access to Main Menu w/o Password	[0] Full access	1 set-up	TRUE	-	UInt8
0-65	Personal Menu Password	200 N/A	1 set-up	TRUE	0	Int16
0-66	Access to Personal Menu w/o Password	[0] Full access	1 set-up	TRUE	-	UInt8
0-7* Clock Settings						
0-70	Set Date and Time	ExpressionLimit	All set-ups	TRUE	0	TimeOfDay
0-71	Date Format	null	1 set-up	TRUE	-	UInt8
0-72	Time Format	null	1 set-up	TRUE	-	UInt8
0-74	DST/Summertime	[0] OFF	1 set-up	TRUE	-	UInt8
0-76	DST/Summertime Start	ExpressionLimit	1 set-up	TRUE	0	TimeOfDay
0-77	DST/Summertime End	ExpressionLimit	1 set-up	TRUE	0	TimeOfDay
0-79	Clock Fault	null	1 set-up	TRUE	-	UInt8
0-81	Working Days	null	1 set-up	TRUE	-	UInt8
0-82	Additional Working Days	ExpressionLimit	1 set-up	TRUE	0	TimeOfDay
0-83	Additional Non-Working Days	ExpressionLimit	1 set-up	TRUE	0	TimeOfDay
0-89	Date and Time Readout	0 N/A	All set-ups	TRUE	0	VisStr[25]

1-** Load / Motor

Par. No. #	Parameter description	Default value	4-set-up	Change during operation	Conversion index	Type
1-0* General Settings						
1-00	Configuration Mode	null	All set-ups	TRUE	-	Uint8
		[3] Auto Energy Optim. VT				
1-03	Torque Characteristics		All set-ups	TRUE	-	Uint8
1-2* Motor Data						
1-20	Motor Power [kW]	ExpressionLimit	All set-ups	FALSE	1	Uint32
1-21	Motor Power [HP]	ExpressionLimit	All set-ups	FALSE	-2	Uint32
1-22	Motor Voltage	ExpressionLimit	All set-ups	FALSE	0	Uint16
1-23	Motor Frequency	ExpressionLimit	All set-ups	FALSE	0	Uint16
1-24	Motor Current	ExpressionLimit	All set-ups	FALSE	-2	Uint32
1-25	Motor Nominal Speed	ExpressionLimit	All set-ups	FALSE	67	Uint16
1-28	Motor Rotation Check	[0] OFF	All set-ups	FALSE	-	Uint8
	Automatic Motor Adaptation					
1-29	(AMA)	[0] Off	All set-ups	FALSE	-	Uint8
1-3* Addl. Motor Data						
1-30	Stator Resistance (Rs)	ExpressionLimit	All set-ups	FALSE	-4	Uint32
1-31	Rotor Resistance (Rr)	ExpressionLimit	All set-ups	FALSE	-4	Uint32
1-35	Main Reactance (Xh)	ExpressionLimit	All set-ups	FALSE	-4	Uint32
1-36	Iron Loss Resistance (Rfe)	ExpressionLimit	All set-ups	FALSE	-3	Uint32
1-39	Motor Poles	ExpressionLimit	All set-ups	FALSE	0	Uint8
1-5* Load-Indep. Setting						
	Motor Magnetization at Zero					
1-50	Speed	100 %	All set-ups	TRUE	0	Uint16
	Min Speed Normal Magnetizing					
1-51	[RPM]	ExpressionLimit	All set-ups	TRUE	67	Uint16
	Min Speed Normal Magnetizing					
1-52	[Hz]	ExpressionLimit	All set-ups	TRUE	-1	Uint16
1-58	Flystart Test Pulses Current	50 %	All set-ups	FALSE	0	Uint16
1-59	Flystart Test Pulses Frequency	200 %	All set-ups	FALSE	0	Uint16

How to program the Frequency Converter

Par. No. #	Parameter description	Default value	4-set-up	Change during operation	Conversion index	Type
1-6* Load-Depend. Settg.						
1-60	Low Speed Load Compensation	100 %	All set-ups	TRUE	0	Int16
1-61	High Speed Load Compensation	100 %	All set-ups	TRUE	0	Int16
1-62	Slip Compensation	0 %	All set-ups	TRUE	0	Int16
1-63	Slip Compensation Time Constant	ExpressionLimit	All set-ups	TRUE	-2	Uint16
1-64	Resonance Dampening	100 %	All set-ups	TRUE	0	Uint16
1-65	Resonance Dampening Time Constant	5 ms	All set-ups	TRUE	-3	Uint8
1-7* Start Adjustments						
1-71	Start Delay	0.0 s	All set-ups	TRUE	-1	Uint16
1-73	Flying Start	[0] Disabled	All set-ups	FALSE	-	Uint8
1-8* Stop Adjustments						
1-80	Function at Stop	[0] Coast	All set-ups	TRUE	-	Uint8
1-81	Min Speed for Function at Stop [RPM]	ExpressionLimit	All set-ups	TRUE	67	Uint16
1-82	Min Speed for Function at Stop [Hz]	ExpressionLimit	All set-ups	TRUE	-1	Uint16
1-86	Trip Speed Low [RPM]	0 RPM	All set-ups	TRUE	67	Uint16
1-87	Trip Speed Low [Hz]	0.0 Hz	All set-ups	TRUE	-1	Uint16
1-9* Motor Temperature						
1-90	Motor Thermal Protection	[4] ETR trip 1	All set-ups	TRUE	-	Uint8
1-91	Motor External Fan	[0] No	All set-ups	TRUE	-	Uint16
1-93	Thermistor Source	[0] None	All set-ups	TRUE	-	Uint8

2-** Brakes

Par. No. #	Parameter description	Default value	4-set-up	Change during operation	Conversion index	Type
2-0* DC Brake						
2-00	DC Hold/Preheat Current	50 %	All set-ups	TRUE	0	Uint8
2-01	DC Brake Current	50 %	All set-ups	TRUE	0	Uint16
2-02	DC Braking Time	10.0 s	All set-ups	TRUE	-1	Uint16
2-03	DC Brake Cut-in Speed [RPM]	ExpressionLimit	All set-ups	TRUE	67	Uint16
2-04	DC Brake Cut-in Speed [Hz]	ExpressionLimit	All set-ups	TRUE	-1	Uint16
2-1* Brake Energy Funct.						
2-10	Brake Function	[0] Off	All set-ups	TRUE	-	Uint8
2-11	Brake Resistor (ohm)	ExpressionLimit	All set-ups	TRUE	0	Uint16
2-12	Brake Power Limit (kW)	ExpressionLimit	All set-ups	TRUE	0	Uint32
2-13	Brake Power Monitoring	[0] Off	All set-ups	TRUE	-	Uint8
2-15	Brake Check	[0] Off	All set-ups	TRUE	-	Uint8
2-16	AC Brake Max. Current	ExpressionLimit	All set-ups	TRUE	-1	Uint32
2-17	Over-voltage Control	[2] Enabled	All set-ups	TRUE	-	Uint8

3-** Reference / Ramps

Par. No. #	Parameter description	Default value	4-set-up	Change during operation	Conversion index	Type
3-0* Reference Limits						
3-02	Minimum Reference	ExpressionLimit	All set-ups	TRUE	-3	Int32
3-03	Maximum Reference	ExpressionLimit	All set-ups	TRUE	-3	Int32
3-04	Reference Function	null	All set-ups	TRUE	-	UInt8
3-1* References						
3-10	Preset Reference	0.00 %	All set-ups	TRUE	-2	Int16
3-11	Jog Speed [Hz]	ExpressionLimit	All set-ups	TRUE	-1	UInt16
		[0] Linked to Hand /				
3-13	Reference Site	Auto	All set-ups	TRUE	-	UInt8
3-14	Preset Relative Reference	0.00 %	All set-ups	TRUE	-2	Int32
3-15	Reference 1 Source	[1] Analog input 53	All set-ups	TRUE	-	UInt8
3-16	Reference 2 Source	[20] Digital pot.meter	All set-ups	TRUE	-	UInt8
3-17	Reference 3 Source	[0] No function	All set-ups	TRUE	-	UInt8
3-19	Jog Speed [RPM]	ExpressionLimit	All set-ups	TRUE	67	UInt16
3-4* Ramp 1						
3-40	Ramp 1 Type	[0] Linear	All set-ups	TRUE	-	UInt8
3-41	Ramp 1 Ramp-up Time	ExpressionLimit	All set-ups	TRUE	-2	UInt32
3-42	Ramp 1 Ramp-down Time	ExpressionLimit	All set-ups	TRUE	-2	UInt32
	Ramp 1 S-ramp Ratio at Accel.					
3-45	Start	50 %	All set-ups	TRUE	0	UInt8
3-46	Ramp 1 S-ramp Ratio at Accel. End	50 %	All set-ups	TRUE	0	UInt8
	Ramp 1 S-ramp Ratio at Decel.					
3-47	Start	50 %	All set-ups	TRUE	0	UInt8
3-48	Ramp 1 S-ramp Ratio at Decel. End	50 %	All set-ups	TRUE	0	UInt8
3-5* Ramp 2						
3-50	Ramp 2 Type	[0] Linear	All set-ups	TRUE	-	UInt8
3-51	Ramp 2 Ramp-up Time	ExpressionLimit	All set-ups	TRUE	-2	UInt32
3-52	Ramp 2 Ramp-down Time	ExpressionLimit	All set-ups	TRUE	-2	UInt32
	Ramp 2 S-ramp Ratio at Accel.					
3-55	Start	50 %	All set-ups	TRUE	0	UInt8
3-56	Ramp 2 S-ramp Ratio at Accel. End	50 %	All set-ups	TRUE	0	UInt8
	Ramp 2 S-ramp Ratio at Decel.					
3-57	Start	50 %	All set-ups	TRUE	0	UInt8
3-58	Ramp 2 S-ramp Ratio at Decel. End	50 %	All set-ups	TRUE	0	UInt8

Par. No. #	Parameter description	Default value	4-set-up	Change during operation	Conversion index	Type
3-8* Other Ramps						
3-80	Jog Ramp Time	ExpressionLimit	All set-ups	TRUE	-2	Uint32
3-81	Quick Stop Ramp Time	ExpressionLimit	2 set-ups	TRUE	-2	Uint32
3-84	Initial Ramp Time	ExpressionLimit	All set-ups	TRUE	-2	Uint16
3-88	Final Ramp Time	ExpressionLimit	All set-ups	TRUE	-2	Uint16
3-9* Digital Pot. meter						
3-90	Step Size	0.10 %	All set-ups	TRUE	-2	Uint16
3-91	Ramp Time	1.00 s	All set-ups	TRUE	-2	Uint32
3-92	Power Restore	[0] Off	All set-ups	TRUE	-	Uint8
3-93	Maximum Limit	100 %	All set-ups	TRUE	0	Int16
3-94	Minimum Limit	0 %	All set-ups	TRUE	0	Int16
3-95	Ramp Delay	ExpressionLimit	All set-ups	TRUE	-3	TimD

4-** Limits / Warnings

Par. No. #	Parameter description	Default value	4-set-up	Change during operation	Conversion index	Type
4-1* Motor Limits						
4-10	Motor Speed Direction	[2] Both directions	All set-ups	FALSE	-	UInt8
4-11	Motor Speed Low Limit [RPM]	ExpressionLimit	All set-ups	TRUE	67	UInt16
4-12	Motor Speed Low Limit [Hz]	ExpressionLimit	All set-ups	TRUE	-1	UInt16
4-13	Motor Speed High Limit [RPM]	ExpressionLimit	All set-ups	TRUE	67	UInt16
4-14	Motor Speed High Limit [Hz]	ExpressionLimit	All set-ups	TRUE	-1	UInt16
4-16	Torque Limit Motor Mode	110.0 %	All set-ups	TRUE	-1	UInt16
4-17	Torque Limit Generator Mode	100.0 %	All set-ups	TRUE	-1	UInt16
4-18	Current Limit	ExpressionLimit	All set-ups	TRUE	-1	UInt32
4-19	Max Output Frequency	ExpressionLimit	All set-ups	FALSE	-1	UInt16
4-5* Adj. Warnings						
4-50	Warning Current Low	0.00 A	All set-ups	TRUE	-2	UInt32
4-51	Warning Current High	I _{maxVLT} (P1637)	All set-ups	TRUE	-2	UInt32
4-52	Warning Speed Low	0 RPM	All set-ups	TRUE	67	UInt16
4-53	Warning Speed High	outputSpeedHighLimit (P413)	All set-ups	TRUE	67	UInt16
4-54	Warning Reference Low	-999999.999 N/A	All set-ups	TRUE	-3	Int32
4-55	Warning Reference High	999999.999 N/A	All set-ups	TRUE	-3	Int32
4-56	Warning Feedback Low	-999999.999 Proc-essCtrlUnit	All set-ups	TRUE	-3	Int32
4-57	Warning Feedback High	999999.999 Proc-essCtrlUnit	All set-ups	TRUE	-3	Int32
4-58	Missing Motor Phase Function	[2] Trip 1000 ms	All set-ups	TRUE	-	UInt8
4-6* Speed Bypass						
4-60	Bypass Speed From [RPM]	ExpressionLimit	All set-ups	TRUE	67	UInt16
4-61	Bypass Speed From [Hz]	ExpressionLimit	All set-ups	TRUE	-1	UInt16
4-62	Bypass Speed to [RPM]	ExpressionLimit	All set-ups	TRUE	67	UInt16
4-63	Bypass Speed To [Hz]	ExpressionLimit	All set-ups	TRUE	-1	UInt16
4-64	Semi-Auto Bypass Set-up	[0] OFF	All set-ups	FALSE	-	UInt8

5-** Digital In / Out

Par. No. #	Parameter description	Default value	4-set-up	Change during operation	Conversion index	Type
5-0* Digital I/O mode						
5-01	Terminal 27 Mode	[0] Input	All set-ups	TRUE	-	Uint8
5-02	Terminal 29 Mode	[0] Input	All set-ups	TRUE	-	Uint8
5-1* Digital Inputs						
5-10	Terminal 18 Digital Input	[8] Start	All set-ups	TRUE	-	Uint8
5-11	Terminal 19 Digital Input	[0] No operation	All set-ups	TRUE	-	Uint8
5-12	Terminal 27 Digital Input	null	All set-ups	TRUE	-	Uint8
5-13	Terminal 29 Digital Input	[14] Jog	All set-ups	TRUE	-	Uint8
5-14	Terminal 32 Digital Input	[0] No operation	All set-ups	TRUE	-	Uint8
5-15	Terminal 33 Digital Input	[0] No operation	All set-ups	TRUE	-	Uint8
5-16	Terminal X30/2 Digital Input	[0] No operation	All set-ups	TRUE	-	Uint8
5-17	Terminal X30/3 Digital Input	[0] No operation	All set-ups	TRUE	-	Uint8
5-18	Terminal X30/4 Digital Input	[0] No operation	All set-ups	TRUE	-	Uint8
5-3* Digital Outputs						
5-30	Terminal 27 Digital Output	[0] No operation	All set-ups	TRUE	-	Uint8
5-31	Terminal 29 digital Output	[0] No operation	All set-ups	TRUE	-	Uint8
5-32	Term X30/6 Digi Out (MCB 101)	[0] No operation	All set-ups	TRUE	-	Uint8
5-33	Term X30/7 Digi Out (MCB 101)	[0] No operation	All set-ups	TRUE	-	Uint8
5-4* Relays						
5-40	Function Relay	null	All set-ups	TRUE	-	Uint8
5-41	On Delay, Relay	0.01 s	All set-ups	TRUE	-2	Uint16
5-42	Off Delay, Relay	0.01 s	All set-ups	TRUE	-2	Uint16
5-5* Pulse Input						
5-50	Term. 29 Low Frequency	100 Hz	All set-ups	TRUE	0	Uint32
5-51	Term. 29 High Frequency	100 Hz	All set-ups	TRUE	0	Uint32
5-52	Term. 29 Low Ref./Feedb. Value	0.000 N/A	All set-ups	TRUE	-3	Int32
5-53	Term. 29 High Ref./Feedb. Value	100.000 N/A	All set-ups	TRUE	-3	Int32
5-54	Pulse Filter Time Constant #29	100 ms	All set-ups	FALSE	-3	Uint16
5-55	Term. 33 Low Frequency	100 Hz	All set-ups	TRUE	0	Uint32
5-56	Term. 33 High Frequency	100 Hz	All set-ups	TRUE	0	Uint32
5-57	Term. 33 Low Ref./Feedb. Value	0.000 N/A	All set-ups	TRUE	-3	Int32
5-58	Term. 33 High Ref./Feedb. Value	100.000 N/A	All set-ups	TRUE	-3	Int32
5-59	Pulse Filter Time Constant #33	100 ms	All set-ups	FALSE	-3	Uint16

How to program the Frequency Converter

Par. No. #	Parameter description	Default value	4-set-up	Change during operation	Conversion index	Type
5-6* Pulse Output						
5-60	Terminal 27 Pulse Output Variable	[0] No operation	All set-ups	TRUE	-	Uint8
5-62	Pulse Output Max Freq #27	5000 Hz	All set-ups	TRUE	0	Uint32
5-63	Terminal 29 Pulse Output Variable	[0] No operation	All set-ups	TRUE	-	Uint8
5-65	Pulse Output Max Freq #29	5000 Hz	All set-ups	TRUE	0	Uint32
5-66	Terminal X30/6 Pulse Output Variable	[0] No operation	All set-ups	TRUE	-	Uint8
5-68	Pulse Output Max Freq #X30/6	5000 Hz	All set-ups	TRUE	0	Uint32
5-9* Bus Controlled						
5-90	Digital & Relay Bus Control	0 N/A	All set-ups	TRUE	0	Uint32
5-93	Pulse Out #27 Bus Control	0.00 %	All set-ups	TRUE	-2	N2
5-94	Pulse Out #27 Timeout Preset	0.00 %	1 set-up	TRUE	-2	Uint16
5-95	Pulse Out #29 Bus Control	0.00 %	All set-ups	TRUE	-2	N2
5-96	Pulse Out #29 Timeout Preset	0.00 %	1 set-up	TRUE	-2	Uint16
5-97	Pulse Out #X30/6 Bus Control	0.00 %	All set-ups	TRUE	-2	N2
5-98	Pulse Out #X30/6 Timeout Preset	0.00 %	1 set-up	TRUE	-2	Uint16

6-** Analog In / Out

Par. No. #	Parameter description	Default value	4-set-up	Change during operation	Conversion index	Type
6-0* Analog I/O Mode						
6-00	Live Zero Timeout Time	10 s	All set-ups	TRUE	0	Uint8
6-01	Live Zero Timeout Function	[0] Off	All set-ups	TRUE	-	Uint8
6-02	Fire Mode Live Zero Timeout Function	[0] Off	All set-ups	TRUE	-	Uint8
6-1* Analog Input 53						
6-10	Terminal 53 Low Voltage	0.07 V	All set-ups	TRUE	-2	Int16
6-11	Terminal 53 High Voltage	10.00 V	All set-ups	TRUE	-2	Int16
6-12	Terminal 53 Low Current	4.00 mA	All set-ups	TRUE	-5	Int16
6-13	Terminal 53 High Current	20.00 mA	All set-ups	TRUE	-5	Int16
6-14	Terminal 53 Low Ref./Feedb. Value	0.000 N/A	All set-ups	TRUE	-3	Int32
6-15	Terminal 53 High Ref./Feedb. Value	ExpressionLimit	All set-ups	TRUE	-3	Int32
6-16	Terminal 53 Filter Time Constant	0.001 s	All set-ups	TRUE	-3	Uint16
6-17	Terminal 53 Live Zero	[1] Enabled	All set-ups	TRUE	-	Uint8
6-2* Analog Input 54						
6-20	Terminal 54 Low Voltage	0.07 V	All set-ups	TRUE	-2	Int16
6-21	Terminal 54 High Voltage	10.00 V	All set-ups	TRUE	-2	Int16
6-22	Terminal 54 Low Current	4.00 mA	All set-ups	TRUE	-5	Int16
6-23	Terminal 54 High Current	20.00 mA	All set-ups	TRUE	-5	Int16
6-24	Terminal 54 Low Ref./Feedb. Value	0.000 N/A	All set-ups	TRUE	-3	Int32
6-25	Terminal 54 High Ref./Feedb. Value	100.000 N/A	All set-ups	TRUE	-3	Int32
6-26	Terminal 54 Filter Time Constant	0.001 s	All set-ups	TRUE	-3	Uint16
6-27	Terminal 54 Live Zero	[1] Enabled	All set-ups	TRUE	-	Uint8
6-3* Analog Input X30/11						
6-30	Terminal X30/11 Low Voltage	0.07 V	All set-ups	TRUE	-2	Int16
6-31	Terminal X30/11 High Voltage	10.00 V	All set-ups	TRUE	-2	Int16
6-34	Term. X30/11 Low Ref./Feedb. Value	0.000 N/A	All set-ups	TRUE	-3	Int32
6-35	Term. X30/11 High Ref./Feedb. Value	100.000 N/A	All set-ups	TRUE	-3	Int32
6-36	Term. X30/11 Filter Time Constant	0.001 s	All set-ups	TRUE	-3	Uint16
6-37	Term. X30/11 Live Zero	[1] Enabled	All set-ups	TRUE	-	Uint8
6-4* Analog Input X30/12						
6-40	Terminal X30/12 Low Voltage	0.07 V	All set-ups	TRUE	-2	Int16
6-41	Terminal X30/12 High Voltage	10.00 V	All set-ups	TRUE	-2	Int16
6-44	Term. X30/12 Low Ref./Feedb. Value	0.000 N/A	All set-ups	TRUE	-3	Int32
6-45	Term. X30/12 High Ref./Feedb. Value	100.000 N/A	All set-ups	TRUE	-3	Int32
6-46	Term. X30/12 Filter Time Constant	0.001 s	All set-ups	TRUE	-3	Uint16
6-47	Term. X30/12 Live Zero	[1] Enabled	All set-ups	TRUE	-	Uint8

How to program the Frequency Converter

Par. No. #	Parameter description	Default value	4-set-up	Change during operation	Conversion index	Type
6-5* Analog Output 42						
6-50	Terminal 42 Output	null	All set-ups	TRUE	-	Uint8
6-51	Terminal 42 Output Min Scale	0.00 %	All set-ups	TRUE	-2	Int16
6-52	Terminal 42 Output Max Scale	100.00 %	All set-ups	TRUE	-2	Int16
6-53	Terminal 42 Output Bus Control	0.00 %	All set-ups	TRUE	-2	N2
6-54	Terminal 42 Output Timeout Pre-set	0.00 %	1 set-up	TRUE	-2	Uint16
6-6* Analog Output X30/8						
6-60	Terminal X30/8 Output	[0] No operation	All set-ups	TRUE	-	Uint8
6-61	Terminal X30/8 Min. Scale	0.00 %	All set-ups	TRUE	-2	Int16
6-62	Terminal X30/8 Max. Scale	100.00 %	All set-ups	TRUE	-2	Int16
6-63	Terminal X30/8 Output Bus Control	0.00 %	All set-ups	TRUE	-2	N2
6-64	Terminal X30/8 Output Timeout Preset	0.00 %	1 set-up	TRUE	-2	Uint16

8-** Communication and Options

Par. No. #	Parameter description	Default value	4-set-up	Change during operation	Conversion index	Type
8-0* General Settings						
8-01	Control Site	null	All set-ups	TRUE	-	Uint8
8-02	Control Source	null	All set-ups	TRUE	-	Uint8
8-03	Control Timeout Time	ExpressionLimit	1 set-up	TRUE	-1	Uint32
8-04	Control Timeout Function	[0] Off	1 set-up	TRUE	-	Uint8
8-05	End-of-Timeout Function	[1] Resume set-up	1 set-up	TRUE	-	Uint8
8-06	Reset Control Timeout	[0] Do not reset	All set-ups	TRUE	-	Uint8
8-07	Diagnosis Trigger	[0] Disable	2 set-ups	TRUE	-	Uint8
8-08	Readout Filtering	null	All set-ups	TRUE	-	Uint8
8-09	Communication Charset	[0] ISO 8859-1	2 set-ups	TRUE	-	Uint8
8-1* Control Settings						
8-10	Control Profile	[0] FC profile	2 set-ups	FALSE	-	Uint8
8-13	Configurable Status Word STW	[1] Profile Default	All set-ups	TRUE	-	Uint8
8-3* FC Port Settings						
8-30	Protocol	null	1 set-up	TRUE	-	Uint8
8-31	Address	ExpressionLimit	1 set-up	TRUE	0	Uint8
8-32	Baud Rate	null	1 set-up	TRUE	-	Uint8
8-33	Parity / Stop Bits	null	1 set-up	TRUE	-	Uint8
8-35	Minimum Response Delay	ExpressionLimit	1 set-up	TRUE	-3	Uint16
8-36	Max Response Delay	ExpressionLimit	1 set-up	TRUE	-3	Uint16
8-37	Max Inter-Char Delay	ExpressionLimit	1 set-up	TRUE	-5	Uint16
8-4* FC MC protocol set						
8-40	Telegram selection	[1] Standard telegram 1	2 set-ups	TRUE	-	Uint8
8-5* Digital/Bus						
8-50	Coasting Select	[3] Logic OR	All set-ups	TRUE	-	Uint8
8-52	DC Brake Select	[3] Logic OR	All set-ups	TRUE	-	Uint8
8-53	Start Select	[3] Logic OR	All set-ups	TRUE	-	Uint8
8-54	Reverse Select	null	All set-ups	TRUE	-	Uint8
8-55	Set-up Select	[3] Logic OR	All set-ups	TRUE	-	Uint8
8-56	Preset Reference Select	[3] Logic OR	All set-ups	TRUE	-	Uint8
8-7* BACnet						
8-70	BACnet Device Instance	1025 N/A	1 set-up	TRUE	0	Uint32
8-72	MS/TP Max Masters	127 N/A	1 set-up	TRUE	0	Uint8
8-73	MS/TP Max Info Frames	1 N/A	1 set-up	TRUE	0	Uint16
8-74	"Startup I am"	[0] Send at power-up	1 set-up	TRUE	-	Uint8
8-75	Initialization Password	ExpressionLimit	1 set-up	TRUE	0	VisStr[25]

How to program the Frequency Converter

Par. No. #	Parameter description	Default value	4-set-up	Change during operation	Conversion index	Type
8-8* FC Port Diagnostics						
8-80	Bus Message Count	0 N/A	All set-ups	TRUE	0	Uint32
8-81	Bus Error Count	0 N/A	All set-ups	TRUE	0	Uint32
8-82	Slave Message Count	0 N/A	All set-ups	TRUE	0	Uint32
8-83	Slave Error Count	0 N/A	All set-ups	TRUE	0	Uint32
8-84	Slave Messages Sent	0 N/A	All set-ups	TRUE	0	Uint32
8-85	Slave Timeout Errors	0 N/A	All set-ups	TRUE	0	Uint32
8-88	Reset FC Port Diagnostics	[0] Do not reset	All set-ups	TRUE	-	Uint8
8-89	Diagnostics Count	0 N/A	1 set-up	TRUE	0	Int32
8-9* Bus Jog						
8-90	Bus Jog 1 Speed	100 RPM	All set-ups	TRUE	67	Uint16
8-91	Bus Jog 2 Speed	200 RPM	All set-ups	TRUE	67	Uint16
8-94	Bus Feedback 1	0 N/A	1 set-up	TRUE	0	N2
8-95	Bus Feedback 2	0 N/A	1 set-up	TRUE	0	N2
8-96	Bus Feedback 3	0 N/A	1 set-up	TRUE	0	N2

11-** LonWorks

Par. No. #	Parameter description	Default value	4-set-up	Change during operation	Conversion index	Type
11-0* LonWorks ID						
11-00	Neuron ID	0 N/A	All set-ups	TRUE	0	OctStr[6]
11-01	Domain	1 N/A	All set-ups	TRUE	0	OctStr[6]
11-02	Subnet ID	0 N/A	All set-ups	TRUE	0	Uint8
11-03	Node ID	0 N/A	All set-ups	TRUE	0	Uint8
11-1* LON Functions						
11-10	Drive Profile	[0] VSD profile	All set-ups	TRUE	-	Uint8
11-15	LON Warning Word	0 N/A	All set-ups	TRUE	0	Uint16
11-17	XIF Revision	0 N/A	All set-ups	TRUE	0	VisStr[5]
11-18	LonWorks Revision	0 N/A	All set-ups	TRUE	0	VisStr[5]
11-2* LON Param. Access						
11-21	Store Data Values	[0] Off	All set-ups	TRUE	-	Uint8

13- Smart Logic Controller**

Par. No. #	Parameter description	Default value	4-set-up	Change during operation	Conversion index	Type
13-0* SLC Settings						
13-00	SL Controller Mode	null	2 set-ups	TRUE	-	UInt8
13-01	Start Event	null	2 set-ups	TRUE	-	UInt8
13-02	Stop Event	null	2 set-ups	TRUE	-	UInt8
13-03	Reset SLC	[0] Do not reset SLC	All set-ups	TRUE	-	UInt8
13-1* Comparators						
13-10	Comparator Operand	null	2 set-ups	TRUE	-	UInt8
13-11	Comparator Operator	null	2 set-ups	TRUE	-	UInt8
13-12	Comparator Value	ExpressionLimit	2 set-ups	TRUE	-3	Int32
13-2* Timers						
13-20	SL Controller Timer	ExpressionLimit	1 set-up	TRUE	-3	TimD
13-4* Logic Rules						
13-40	Logic Rule Boolean 1	null	2 set-ups	TRUE	-	UInt8
13-41	Logic Rule Operator 1	null	2 set-ups	TRUE	-	UInt8
13-42	Logic Rule Boolean 2	null	2 set-ups	TRUE	-	UInt8
13-43	Logic Rule Operator 2	null	2 set-ups	TRUE	-	UInt8
13-44	Logic Rule Boolean 3	null	2 set-ups	TRUE	-	UInt8
13-5* States						
13-51	SL Controller Event	null	2 set-ups	TRUE	-	UInt8
13-52	SL Controller Action	null	2 set-ups	TRUE	-	UInt8

14-** Special Functions

Par. No. #	Parameter description	Default value	4-set-up	Change during operation	Conversion index	Type
14-0* Inverter Switching						
14-00	Switching Pattern	[0] 60 AVM	All set-ups	TRUE	-	Uint8
14-01	Switching Frequency	null	All set-ups	TRUE	-	Uint8
14-03	Overmodulation	[1] On	All set-ups	FALSE	-	Uint8
14-04	PWM Random	[0] Off	All set-ups	TRUE	-	Uint8
14-1* Mains On/Off						
14-10	Line Failure	[0] No function	All set-ups	FALSE	-	Uint8
14-11	Line Voltage at Line Fault	ExpressionLimit	All set-ups	TRUE	0	Uint16
14-12	Function at Mains Imbalance	[0] Trip	All set-ups	TRUE	-	Uint8
14-2* Reset Functions						
14-20	Reset Mode	null	All set-ups	TRUE	-	Uint8
14-21	Automatic Restart Time	10 s	All set-ups	TRUE	0	Uint16
14-22	Operation Mode	[0] Normal operation	All set-ups	TRUE	-	Uint8
14-23	Typecode Setting	null	2 set-ups	FALSE	-	Uint8
14-25	Trip Delay at Torque Limit	60 s	All set-ups	TRUE	0	Uint8
14-26	Trip Delay at Inverter Fault	ExpressionLimit	All set-ups	TRUE	0	Uint8
14-28	Production Settings	[0] No action	All set-ups	TRUE	-	Uint8
14-29	Service Code	0 N/A	All set-ups	TRUE	0	Int32
14-3* Current Limit Ctrl.						
Current Lim Cont, Proportional						
14-30	Gain	100 %	All set-ups	FALSE	0	Uint16
Current Lim Contr, Integration						
14-31	Time	0.020 s	All set-ups	FALSE	-3	Uint16
14-32	Current Lim Ctrl, Filter Time	26.0 ms	All set-ups	TRUE	-4	Uint16
14-4* Energy Optimizing						
14-40	VT Level	66 %	All set-ups	FALSE	0	Uint8
14-41	AEO Minimum Magnetization	ExpressionLimit	All set-ups	TRUE	0	Uint8
14-42	Minimum AEO Frequency	10 Hz	All set-ups	TRUE	0	Uint8
14-43	Motor Cos-Phi	ExpressionLimit	All set-ups	TRUE	-2	Uint16
14-5* Environment						
14-50	RFI 1	[1] On	1 set-up	FALSE	-	Uint8
14-52	Fan Control	[0] Auto	All set-ups	TRUE	-	Uint8
14-53	Fan Monitor	[1] Warning	All set-ups	TRUE	-	Uint8
14-59	Actual Number of Inverter Units	ExpressionLimit	1 set-up	FALSE	0	Uint8
14-6* Auto Derate						
14-60	Function at Overtemperature	[0] Trip	All set-ups	TRUE	-	Uint8
14-61	Function at Inverter Overload	[0] Trip	All set-ups	TRUE	-	Uint8
14-62	Inv. Overload Derate Current	95 %	All set-ups	TRUE	0	Uint16

15-** Drive Information

Par. No. #	Parameter description	Default value	4-set-up	Change during operation	Conversion index	Type
15-0* Operating Data						
15-00	Operating Hours	0 h	All set-ups	FALSE	74	Uint32
15-01	Running Hours	0 h	All set-ups	FALSE	74	Uint32
15-02	Input kWh Counter	0 kWh	All set-ups	FALSE	75	Uint32
15-03	Power-ups	0 N/A	All set-ups	FALSE	0	Uint32
15-04	Over Temps	0 N/A	All set-ups	FALSE	0	Uint16
15-05	Over Volts	0 N/A	All set-ups	FALSE	0	Uint16
15-06	Reset kWh Counter	[0] Do not reset	All set-ups	TRUE	-	Uint8
15-07	Reset Running Hours Counter	[0] Do not reset	All set-ups	TRUE	-	Uint8
15-08	Number of Starts	0 N/A	All set-ups	FALSE	0	Uint32
15-1* Data Log Settings						
15-10	Logging Source	0	2 set-ups	TRUE	-	Uint16
15-11	Logging Interval	ExpressionLimit	2 set-ups	TRUE	-3	TimD
15-12	Trigger Event	[0] FALSE	1 set-up	TRUE	-	Uint8
15-13	Logging Mode	[0] Log always	2 set-ups	TRUE	-	Uint8
15-14	Samples Before Trigger	50 N/A	2 set-ups	TRUE	0	Uint8
15-2* Historic Log						
15-20	Historic Log: Event	0 N/A	All set-ups	FALSE	0	Uint8
15-21	Historic Log: Value	0 N/A	All set-ups	FALSE	0	Uint32
15-22	Historic Log: Time	0 ms	All set-ups	FALSE	-3	Uint32
15-23	Historic Log: Date and Time	ExpressionLimit	All set-ups	FALSE	0	TimeOfDay
15-3* Alarm Log						
15-30	Alarm Log: Error Code	0 N/A	All set-ups	FALSE	0	Uint8
15-31	Alarm Log: Value	0 N/A	All set-ups	FALSE	0	Int16
15-32	Alarm Log: Time	0 s	All set-ups	FALSE	0	Uint32
15-33	Alarm Log: Date and Time	ExpressionLimit	All set-ups	FALSE	0	TimeOfDay
15-4* Drive Identification						
15-40	FC Type	0 N/A	All set-ups	FALSE	0	VisStr[6]
15-41	Power Section	0 N/A	All set-ups	FALSE	0	VisStr[20]
15-42	Voltage	0 N/A	All set-ups	FALSE	0	VisStr[20]
15-43	Software Version	0 N/A	All set-ups	FALSE	0	VisStr[5]
15-44	Ordered Typecode String	0 N/A	All set-ups	FALSE	0	VisStr[40]
15-45	Actual Typecode String	0 N/A	All set-ups	FALSE	0	VisStr[40]
15-46	Adj Freq Dr Ordering No.	0 N/A	All set-ups	FALSE	0	VisStr[8]
15-47	Power Card Ordering No.	0 N/A	All set-ups	FALSE	0	VisStr[8]
15-48	LCP ID Num.	0 N/A	All set-ups	FALSE	0	VisStr[20]
15-49	SW ID Control Card	0 N/A	All set-ups	FALSE	0	VisStr[20]
15-50	SW ID Power Card	0 N/A	All set-ups	FALSE	0	VisStr[20]
15-51	Adj Freq Dr Serial No.	0 N/A	All set-ups	FALSE	0	VisStr[10]
15-53	Power Card Serial Number	0 N/A	All set-ups	FALSE	0	VisStr[19]
15-59	CSIV Filename	ExpressionLimit	1 set-up	FALSE	0	VisStr[16]

How to program the Frequency Converter

Par. No. #	Parameter description	Default value	4-set-up	Change during operation	Conversion index	Type
15-6* Option Ident						
15-60	Option Mounted	0 N/A	All set-ups	FALSE	0	VisStr[30]
15-61	Option SW Version	0 N/A	All set-ups	FALSE	0	VisStr[20]
15-62	Option Ordering No	0 N/A	All set-ups	FALSE	0	VisStr[8]
15-63	Option Serial No	0 N/A	All set-ups	FALSE	0	VisStr[18]
15-70	Option in Slot A	0 N/A	All set-ups	FALSE	0	VisStr[30]
15-71	Slot A Option SW Version	0 N/A	All set-ups	FALSE	0	VisStr[20]
15-72	Option in Slot B	0 N/A	All set-ups	FALSE	0	VisStr[30]
15-73	Slot B Option SW Version	0 N/A	All set-ups	FALSE	0	VisStr[20]
15-74	Option in Slot C0	0 N/A	All set-ups	FALSE	0	VisStr[30]
15-75	Slot C0 Option SW Version	0 N/A	All set-ups	FALSE	0	VisStr[20]
15-76	Option in Slot C1	0 N/A	All set-ups	FALSE	0	VisStr[30]
15-77	Slot C1 Option SW Version	0 N/A	All set-ups	FALSE	0	VisStr[20]
15-9* Parameter Info						
15-92	Defined Parameters	0 N/A	All set-ups	FALSE	0	Uint16
15-93	Modified Parameters	0 N/A	All set-ups	FALSE	0	Uint16
15-98	Drive Identification	0 N/A	All set-ups	FALSE	0	VisStr[40]
15-99	Parameter Metadata	0 N/A	All set-ups	FALSE	0	Uint16

16-** Data Readouts

Par. No. #	Parameter description	Default value	4-set-up	Change during operation	Conversion index	Type
16-0* General Status						
16-00	Control Word	0 N/A	All set-ups	FALSE	0	V2
16-01	Reference [Unit]	0.000 Reference-FeedbackUnit	All set-ups	FALSE	-3	Int32
16-02	Reference %	0.0 %	All set-ups	FALSE	-1	Int16
16-03	Status Word	0 N/A	All set-ups	FALSE	0	V2
16-05	Main Actual Value [%]	0.00 %	All set-ups	FALSE	-2	N2
16-09	Custom Readout	0.00 CustomReadoutUnit	All set-ups	FALSE	-2	Int32
16-1* Motor Status						
16-10	Input Power [kW]	0.00 kW	All set-ups	FALSE	1	Int32
16-11	Input Power [hp]	0.00 hp	All set-ups	FALSE	-2	Int32
16-12	Motor voltage	0.0 V	All set-ups	FALSE	-1	Uint16
16-13	Frequency	0.0 Hz	All set-ups	FALSE	-1	Uint16
16-14	Motor Current	0.00 A	All set-ups	FALSE	-2	Int32
16-15	Frequency [%]	0.00 %	All set-ups	FALSE	-2	N2
16-16	Torque [Nm]	0.0 Nm	All set-ups	FALSE	-1	Int32
16-17	Speed [RPM]	0 RPM	All set-ups	FALSE	67	Int32
16-18	Motor Thermal	0 %	All set-ups	FALSE	0	Uint8
16-22	Torque [%]	0 %	All set-ups	FALSE	0	Int16
16-3* Drive Status						
16-30	DC Link Voltage	0 V	All set-ups	FALSE	0	Uint16
16-32	Brake Energy /s	0.000 kW	All set-ups	FALSE	0	Uint32
16-33	Brake Energy /2 min	0.000 kW	All set-ups	FALSE	0	Uint32
16-34	Heatsink Temp.	0 °C	All set-ups	FALSE	100	Uint8
16-35	Inverter Thermal	0 %	All set-ups	FALSE	0	Uint8
16-36	Inv. Nom. Current	ExpressionLimit	All set-ups	FALSE	-2	Uint32
16-37	Inv. Max. Current	ExpressionLimit	All set-ups	FALSE	-2	Uint32
16-38	SL Controller State	0 N/A	All set-ups	FALSE	0	Uint8
16-39	Control Card Temp.	0 °C	All set-ups	FALSE	100	Uint8
16-40	Logging Buffer Full	[0] No	All set-ups	TRUE	-	Uint8
[0] Timed Actions						
16-43	Timed Actions Status	Auto	All set-ups	TRUE	-	Uint8
16-49	Current Fault Source	0 N/A	All set-ups	TRUE	0	Uint8
16-5* Ref. & Feedb.						
16-50	External Reference	0.0 N/A	All set-ups	FALSE	-1	Int16
16-52	Feedback [Unit]	0.000 ProcessCtrlUnit	All set-ups	FALSE	-3	Int32
16-53	Digi Pot Reference	0.00 N/A	All set-ups	FALSE	-2	Int16
16-54	Feedback 1 [Unit]	0.000 ProcessCtrlUnit	All set-ups	FALSE	-3	Int32
16-55	Feedback 2 [Unit]	0.000 ProcessCtrlUnit	All set-ups	FALSE	-3	Int32
16-56	Feedback 3 [Unit]	0.000 ProcessCtrlUnit	All set-ups	FALSE	-3	Int32
16-58	PID Output [%]	0.0 %	All set-ups	TRUE	-1	Int16

Par. No. #	Parameter description	Default value	4-set-up	Change during operation	Conversion index	Type
16-6* Inputs & Outputs						
16-60	Digital Input	0 N/A	All set-ups	FALSE	0	Uint16
16-61	Terminal 53 Switch Setting	[0] Current	All set-ups	FALSE	-	Uint8
16-62	Analog Input 53	0.000 N/A	All set-ups	FALSE	-3	Int32
16-63	Terminal 54 Switch Setting	[0] Current	All set-ups	FALSE	-	Uint8
16-64	Analog Input 54	0.000 N/A	All set-ups	FALSE	-3	Int32
16-65	Analog Output 42 [mA]	0.000 N/A	All set-ups	FALSE	-3	Int16
16-66	Digital Output [bin]	0 N/A	All set-ups	FALSE	0	Int16
16-67	Pulse Input #29 [Hz]	0 N/A	All set-ups	FALSE	0	Int32
16-68	Pulse Input #33 [Hz]	0 N/A	All set-ups	FALSE	0	Int32
16-69	Pulse Output #27 [Hz]	0 N/A	All set-ups	FALSE	0	Int32
16-70	Pulse Output #29 [Hz]	0 N/A	All set-ups	FALSE	0	Int32
16-71	Relay Output [bin]	0 N/A	All set-ups	FALSE	0	Int16
16-72	Counter A	0 N/A	All set-ups	TRUE	0	Int32
16-73	Counter B	0 N/A	All set-ups	TRUE	0	Int32
16-75	Analog In X30/11	0.000 N/A	All set-ups	FALSE	-3	Int32
16-76	Analog In X30/12	0.000 N/A	All set-ups	FALSE	-3	Int32
16-77	Analog Out X30/8 [mA]	0.000 N/A	All set-ups	FALSE	-3	Int16
16-8* Fieldbus & FC Port						
16-80	Fieldbus CTW 1	0 N/A	All set-ups	FALSE	0	V2
16-82	Fieldbus REF 1	0 N/A	All set-ups	FALSE	0	N2
16-84	Comm. Option Status	0 N/A	All set-ups	FALSE	0	V2
16-85	FC Port CTW 1	0 N/A	All set-ups	FALSE	0	V2
16-86	FC Port REF 1	0 N/A	All set-ups	FALSE	0	N2
16-9* Diagnosis Readouts						
16-90	Alarm Word	0 N/A	All set-ups	FALSE	0	Uint32
16-91	Alarm word 2	0 N/A	All set-ups	FALSE	0	Uint32
16-92	Warning Word	0 N/A	All set-ups	FALSE	0	Uint32
16-93	Warning word 2	0 N/A	All set-ups	FALSE	0	Uint32
16-94	Ext. Status Word	0 N/A	All set-ups	FALSE	0	Uint32
16-95	Ext. Status Word 2	0 N/A	All set-ups	FALSE	0	Uint32
16-96	Maintenance Word	0 N/A	All set-ups	FALSE	0	Uint32

18-** Info & Readouts

Par. No. #	Parameter description	Default value	4-set-up	Change during operation	Conversion index	Type
18-0* Maintenance Log						
18-00	Maintenance Log: Item	0 N/A	All set-ups	FALSE	0	UInt8
18-01	Maintenance Log: Action	0 N/A	All set-ups	FALSE	0	UInt8
18-02	Maintenance Log: Time	0 s	All set-ups	FALSE	0	UInt32
18-03	Maintenance Log: Date and Time	ExpressionLimit	All set-ups	FALSE	0	TimeOf-Day
18-1* Fire Mode Log						
18-10	Fire Mode Log: Event	0 N/A	All set-ups	FALSE	0	UInt8
18-11	Fire Mode Log: Time	0 s	All set-ups	FALSE	0	UInt32
18-12	Fire Mode Log: Date and Time	ExpressionLimit	All set-ups	FALSE	0	TimeOf-Day
18-4* PGIO Data Readouts						
18-40	Analog Input X49/1	0.000 N/A	All set-ups	FALSE	-3	Int32
18-41	Analog Input X49/3	0.000 N/A	All set-ups	FALSE	-3	Int32
18-42	Analog Input X49/5	0.000 N/A	All set-ups	FALSE	-3	Int32
18-43	Analog Output X49/7	0.000 N/A	All set-ups	FALSE	-3	Int16
18-44	Analog Output X49/9	0.000 N/A	All set-ups	FALSE	-3	Int16
18-45	Analog Output X49/11	0.000 N/A	All set-ups	FALSE	-3	Int16
18-46	X49 Digital Output [bin]	0 N/A	All set-ups	FALSE	0	Int16

20-** Drive Closed Loop

Par. No. #	Parameter description	Default value	4-set-up	Change during operation	Conversion index	Type
20-0* Feedback						
20-00	Feedback 1 Source	[2] Analog input 54	All set-ups	TRUE	-	UInt8
20-01	Feedback 1 Conversion	[0] Linear	All set-ups	FALSE	-	UInt8
20-02	Feedback 1 Source Unit	null	All set-ups	TRUE	-	UInt8
20-03	Feedback 2 Source	[0] No function	All set-ups	TRUE	-	UInt8
20-04	Feedback 2 Conversion	[0] Linear	All set-ups	FALSE	-	UInt8
20-05	Feedback 2 Source Unit	null	All set-ups	TRUE	-	UInt8
20-06	Feedback 3 Source	[0] No function	All set-ups	TRUE	-	UInt8
20-07	Feedback 3 Conversion	[0] Linear	All set-ups	FALSE	-	UInt8
20-08	Feedback 3 Source Unit	null	All set-ups	TRUE	-	UInt8
20-12	Reference/Feedback Unit	null	All set-ups	TRUE	-	UInt8
20-13	Minimum Reference/Feedb.	0.000 ProcessCtrlUnit	All set-ups	TRUE	-3	Int32
20-14	Maximum Reference/Feedb.	100.000 ProcessCtrlUnit	All set-ups	TRUE	-3	Int32
20-2* Feedback & Setpoint						
20-20	Feedback Function	[3] Minimum	All set-ups	TRUE	-	UInt8
20-21	Setpoint 1	0.000 ProcessCtrlUnit	All set-ups	TRUE	-3	Int32
20-22	Setpoint 2	0.000 ProcessCtrlUnit	All set-ups	TRUE	-3	Int32
20-23	Setpoint 3	0.000 ProcessCtrlUnit	All set-ups	TRUE	-3	Int32
20-3* Feedback Adv Conv						
20-30	Refrigerant	[0] R22	All set-ups	TRUE	-	UInt8
20-31	User-defined Refrigerant A1	10.0000 N/A	All set-ups	TRUE	-4	UInt32
20-32	User-defined Refrigerant A2	-2250.00 N/A	All set-ups	TRUE	-2	Int32
20-33	User-defined Refrigerant A3	250.000 N/A	All set-ups	TRUE	-3	UInt32
20-7* PID Auto Tuning						
20-70	Closed-loop Type	[0] Auto	2 set-ups	TRUE	-	UInt8
20-71	Tuning Mode	[0] Normal	2 set-ups	TRUE	-	UInt8
20-72	PID Output Change	0.10 N/A	2 set-ups	TRUE	-2	UInt16
20-73	Minimum Feedback Level	-999999.000 ProcessCtrlUnit	2 set-ups	TRUE	-3	Int32
20-74	Maximum Feedback Level	999999.000 ProcessCtrlUnit	2 set-ups	TRUE	-3	Int32
20-79	PID Auto Tuning	[0] Disabled	All set-ups	TRUE	-	UInt8

Par. No. #	Parameter description	Default value	4-set-up	Change during operation	Conversion index	Type
20-8* PID Basic Settings						
20-81	PID Normal/ Inverse Control	[0] Normal	All set-ups	TRUE	-	Uint8
20-82	PID Start Speed [RPM]	ExpressionLimit	All set-ups	TRUE	67	Uint16
20-83	PID Start Speed [Hz]	ExpressionLimit	All set-ups	TRUE	-1	Uint16
20-84	On Reference Bandwidth	5 %	All set-ups	TRUE	0	Uint8
20-9* PID Controller						
20-91	PID Anti Windup	[1] On	All set-ups	TRUE	-	Uint8
20-93	PID Proportional Gain	0.50 N/A	All set-ups	TRUE	-2	Uint16
20-94	PID Integral Time	20.00 s	All set-ups	TRUE	-2	Uint32
20-95	PID Differentiation Time	0.00 s	All set-ups	TRUE	-2	Uint16
20-96	PID Diff. Gain Limit	5.0 N/A	All set-ups	TRUE	-1	Uint16

21-** Ext. Closed Loop

Par. No. #	Parameter description	Default value	4-set-up	Change during operation	Conversion index	Type
21-0* Ext. PID Auto-tuning						
21-00	Closed-loop Type	[0] Auto	2 set-ups	TRUE	-	Uint8
21-01	Tuning Mode	[0] Normal	2 set-ups	TRUE	-	Uint8
21-02	PID Output Change	0.10 N/A	2 set-ups	TRUE	-2	Uint16
21-03	Minimum Feedback Level	-999999.000 N/A	2 set-ups	TRUE	-3	Int32
21-04	Maximum Feedback Level	999999.000 N/A	2 set-ups	TRUE	-3	Int32
21-09	PID Auto Tuning	[0] Disabled	All set-ups	TRUE	-	Uint8
21-1* Ext. CL 1 Ref./Fb.						
21-10	Ext. 1 Ref./Feedback Unit	[1] %	All set-ups	TRUE	-	Uint8
21-11	Ext. 1 Minimum Reference	0.000 ExtPID1Unit	All set-ups	TRUE	-3	Int32
21-12	Ext. 1 Maximum Reference	100.000 ExtPID1Unit	All set-ups	TRUE	-3	Int32
21-13	Ext. 1 Reference Source	[0] No function	All set-ups	TRUE	-	Uint8
21-14	Ext. 1 Feedback Source	[0] No function	All set-ups	TRUE	-	Uint8
21-15	Ext. 1 Setpoint	0.000 ExtPID1Unit	All set-ups	TRUE	-3	Int32
21-17	Ext. 1 Reference [Unit]	0.000 ExtPID1Unit	All set-ups	TRUE	-3	Int32
21-18	Ext. 1 Feedback [Unit]	0.000 ExtPID1Unit	All set-ups	TRUE	-3	Int32
21-19	Ext. 1 Output [%]	0 %	All set-ups	TRUE	0	Int32
21-2* Ext. CL 1 PID						
21-20	Ext. 1 Normal/Inverse Control	[0] Normal	All set-ups	TRUE	-	Uint8
21-21	Ext. 1 Proportional Gain	0.01 N/A	All set-ups	TRUE	-2	Uint16
21-22	Ext. 1 Integral Time	10000.00 s	All set-ups	TRUE	-2	Uint32
21-23	Ext. 1 Differentiation Time	0.00 s	All set-ups	TRUE	-2	Uint16
21-24	Ext. 1 Dif. Gain Limit	5.0 N/A	All set-ups	TRUE	-1	Uint16
21-3* Ext. CL 2 Ref./Fb.						
21-30	Ext. 2 Ref./Feedback Unit	[1] %	All set-ups	TRUE	-	Uint8
21-31	Ext. 2 Minimum Reference	0.000 ExtPID2Unit	All set-ups	TRUE	-3	Int32
21-32	Ext. 2 Maximum Reference	100.000 ExtPID2Unit	All set-ups	TRUE	-3	Int32
21-33	Ext. 2 Reference Source	[0] No function	All set-ups	TRUE	-	Uint8
21-34	Ext. 2 Feedback Source	[0] No function	All set-ups	TRUE	-	Uint8
21-35	Ext. 2 Setpoint	0.000 ExtPID2Unit	All set-ups	TRUE	-3	Int32
21-37	Ext. 2 Reference [Unit]	0.000 ExtPID2Unit	All set-ups	TRUE	-3	Int32
21-38	Ext. 2 Feedback [Unit]	0.000 ExtPID2Unit	All set-ups	TRUE	-3	Int32
21-39	Ext. 2 Output [%]	0 %	All set-ups	TRUE	0	Int32
21-4* Ext. CL 2 PID						
21-40	Ext. 2 Normal/Inverse Control	[0] Normal	All set-ups	TRUE	-	Uint8
21-41	Ext. 2 Proportional Gain	0.01 N/A	All set-ups	TRUE	-2	Uint16
21-42	Ext. 2 Integral Time	10000.00 s	All set-ups	TRUE	-2	Uint32
21-43	Ext. 2 Differentiation Time	0.00 s	All set-ups	TRUE	-2	Uint16
21-44	Ext. 2 Dif. Gain Limit	5.0 N/A	All set-ups	TRUE	-1	Uint16

Par. No. #	Parameter description	Default value	4-set-up	Change during operation	Conversion index	Type
21-5* Ext. CL 3 Ref./Fb.						
21-50	Ext. 3 Ref./Feedback Unit	[1] %	All set-ups	TRUE	-	UInt8
21-51	Ext. 3 Minimum Reference	0.000 ExtPID3Unit	All set-ups	TRUE	-3	Int32
21-52	Ext. 3 Maximum Reference	100.000 ExtPID3Unit	All set-ups	TRUE	-3	Int32
21-53	Ext. 3 Reference Source	[0] No function	All set-ups	TRUE	-	UInt8
21-54	Ext. 3 Feedback Source	[0] No function	All set-ups	TRUE	-	UInt8
21-55	Ext. 3 Setpoint	0.000 ExtPID3Unit	All set-ups	TRUE	-3	Int32
21-57	Ext. 3 Reference [Unit]	0.000 ExtPID3Unit	All set-ups	TRUE	-3	Int32
21-58	Ext. 3 Feedback [Unit]	0.000 ExtPID3Unit	All set-ups	TRUE	-3	Int32
21-59	Ext. 3 Output [%]	0 %	All set-ups	TRUE	0	Int32
21-6* Ext. CL 3 PID						
21-60	Ext. 3 Normal/Inverse Control	[0] Normal	All set-ups	TRUE	-	UInt8
21-61	Ext. 3 Proportional Gain	0.01 N/A	All set-ups	TRUE	-2	UInt16
21-62	Ext. 3 Integral Time	10000.00 s	All set-ups	TRUE	-2	UInt32
21-63	Ext. 3 Differentiation Time	0.00 s	All set-ups	TRUE	-2	UInt16
21-64	Ext. 3 Dif. Gain Limit	5.0 N/A	All set-ups	TRUE	-1	UInt16

22-** Application Functions

Par. No. #	Parameter description	Default value	4-set-up	Change during operation	Conversion index	Type
22-0* Miscellaneous						
22-00	External Interlock Delay	0 s	All set-ups	TRUE	0	UInt16
22-2* No-Flow Detection						
22-22	Low Speed Detection	[0] Disabled	All set-ups	TRUE	-	UInt8
22-23	No-Flow Function	[0] OFF	All set-ups	TRUE	-	UInt8
22-24	No-Flow Delay	10 s	All set-ups	TRUE	0	UInt16
22-4* Sleep Mode						
22-40	Minimum Run Time	10 s	All set-ups	TRUE	0	UInt16
22-41	Minimum Sleep Time	10 s	All set-ups	TRUE	0	UInt16
22-42	Wake-up Speed [RPM]	ExpressionLimit	All set-ups	TRUE	67	UInt16
22-43	Wake-up Speed [Hz]	ExpressionLimit	All set-ups	TRUE	-1	UInt16
22-44	Wake-up Ref./FB Difference	10 %	All set-ups	TRUE	0	Int8
22-45	Setpoint Boost	0 %	All set-ups	TRUE	0	Int8
22-46	Maximum Boost Time	60 s	All set-ups	TRUE	0	UInt16
22-6* Broken Belt Detection						
22-60	Broken Belt Function	[0] OFF	All set-ups	TRUE	-	UInt8
22-61	Broken Belt Torque	10 %	All set-ups	TRUE	0	UInt8
22-62	Broken Belt Delay	10 s	All set-ups	TRUE	0	UInt16
22-7* Short Cycle Protection						
22-75	Short Cycle Protection	[0] Disabled	All set-ups	TRUE	-	UInt8
22-76	Interval between Starts	start_to_start_min_o n_time (P2277)	All set-ups	TRUE	0	UInt16
22-77	Minimum Run Time	0 s	All set-ups	TRUE	0	UInt16

23-** Time Based Functions

Par. No. #	Parameter description	Default value	4-set-up	Change during operation	Conversion index	Type
23-0* Timed Actions						
23-00	ON Time	ExpressionLimit	2 set-ups	TRUE	0	TimeOf-DayWo-Date
23-01	ON Action	[0] DISABLED	2 set-ups	TRUE	-	Uint8
23-02	OFF Time	ExpressionLimit	2 set-ups	TRUE	0	TimeOf-DayWo-Date
23-03	OFF Action	[1] No action	2 set-ups	TRUE	-	Uint8
23-04	Occurrence	[0] All days	2 set-ups	TRUE	-	Uint8
23-0* Timed Actions Settings						
		[0] Timed Actions				
23-08	Timed Actions Mode	Auto	2 set-ups	TRUE	-	Uint8
23-09	Timed Actions Reactivation	[1] Enabled	2 set-ups	TRUE	-	Uint8
23-1* Maintenance						
23-10	Maintenance Item	[1] Motor bearings	1 set-up	TRUE	-	Uint8
23-11	Maintenance Action	[1] Lubricate	1 set-up	TRUE	-	Uint8
23-12	Maintenance Time Base	[0] Disabled	1 set-up	TRUE	-	Uint8
23-13	Maintenance Time Interval	1 h	1 set-up	TRUE	74	Uint32
23-14	Maintenance Date and Time	ExpressionLimit	1 set-up	TRUE	0	TimeOf-Day
23-1* Maintenance Reset						
23-15	Reset Maintenance Word	[0] Do not reset	All set-ups	TRUE	-	Uint8
23-16	Maintenance Text	0 N/A	1 set-up	TRUE	0	VisStr[20]
23-5* Energy Log						
23-50	Energy Log Resolution	[5] Last 24 Hours	2 set-ups	TRUE	-	Uint8
23-51	Period Start	ExpressionLimit	2 set-ups	TRUE	0	TimeOf-Day
23-53	Energy Log	0 N/A	All set-ups	TRUE	0	Uint32
23-54	Reset Energy Log	[0] Do not reset	All set-ups	TRUE	-	Uint8
23-6* Trending						
23-60	Trend Variable	[0] Power [kW]	2 set-ups	TRUE	-	Uint8
23-61	Continuous Bin Data	0 N/A	All set-ups	TRUE	0	Uint32
23-62	Timed Bin Data	0 N/A	All set-ups	TRUE	0	Uint32
23-63	Timed Period Start	ExpressionLimit	2 set-ups	TRUE	0	TimeOf-Day
23-64	Timed Period Stop	ExpressionLimit	2 set-ups	TRUE	0	TimeOf-Day
23-65	Minimum Bin Value	ExpressionLimit	2 set-ups	TRUE	0	Uint8
23-66	Reset Continuous Bin Data	[0] Do not reset	All set-ups	TRUE	-	Uint8
23-67	Reset Timed Bin Data	[0] Do not reset	All set-ups	TRUE	-	Uint8
23-8* Payback Counter						
23-80	Power Reference Factor	100 %	2 set-ups	TRUE	0	Uint8
23-81	Energy Cost	1.00 N/A	2 set-ups	TRUE	-2	Uint32
23-82	Investment	0 N/A	2 set-ups	TRUE	0	Uint32
23-83	Energy Savings	0 kWh	All set-ups	TRUE	75	Int32
23-84	Cost Savings	0 N/A	All set-ups	TRUE	0	Int32

24- Application Functions 2**

Par. No. #	Parameter description	Default value	4-set-up	Change during operation	Conversion index	Type
24-0* Fire Mode						
24-00	Fire Mode Function	[0] Disabled	2 set-ups	TRUE	-	UInt8
24-03	Fire Mode Min Reference	ExpressionLimit	All set-ups	TRUE	-3	Int32
24-04	Fire Mode Max Reference	ExpressionLimit	All set-ups	TRUE	-3	Int32
24-05	Fire Mode Preset Reference	0.00 %	All set-ups	TRUE	-2	Int16
24-06	Fire Mode Reference Source	[0] No function	All set-ups	TRUE	-	UInt8
		[1] Trip at Critical Alarms				
24-09	Fire Mode Alarm Handling	Alarms	2 set-ups	FALSE	-	UInt8
24-1* Drive Bypass						
24-10	Bypass Function	[0] Disabled	2 set-ups	TRUE	-	UInt8
24-11	Bypass Delay Time	0 s	2 set-ups	TRUE	0	UInt16

36-** Programmable I/O Option

Par. No. #	Parameter description	Default value	4-set-up	Change during operation	Conversion index	Type
36-0* I/O Mode						
36-00	Terminal X49/1 Mode	[1] Voltage	All set-ups	TRUE	-	Uint8
36-01	Terminal X49/3 Mode	[1] Voltage	All set-ups	TRUE	-	Uint8
36-02	Terminal X49/5 Mode	[1] Voltage	All set-ups	TRUE	-	Uint8
36-03	Terminal X49/7 Mode	[0] Voltage 0-10 V	All set-ups	TRUE	-	Uint8
36-04	Terminal X49/9 Mode	[0] Voltage 0-10 V	All set-ups	TRUE	-	Uint8
36-05	Terminal X49/11 Mode	[0] Voltage 0-10 V	All set-ups	TRUE	-	Uint8
36-1* Analog Input X49/1						
36-10	Terminal X49/1 Low Voltage	0.07 V	All set-ups	TRUE	-2	Int16
36-11	Terminal X49/1 Low Current	4.00 mA	All set-ups	TRUE	-5	Int16
36-12	Terminal X49/1 High Voltage	10.00 V	All set-ups	TRUE	-2	Int16
36-13	Terminal X49/1 High Current	20.00 mA	All set-ups	TRUE	-5	Int16
36-14	Term. X49/1 Low Ref./Feedb. Value	0.000 N/A	All set-ups	TRUE	-3	Int32
36-15	Term. X49/1 High Ref./Feedb. Value	100.000 N/A	All set-ups	TRUE	-3	Int32
36-16	Term. X49/1 Filter Time Constant	0.001 s	All set-ups	TRUE	-3	Uint16
36-17	Term. X49/1 Live Zero	[1] Enabled	All set-ups	TRUE	-	Uint8
36-2* Analog Input X49/3						
36-20	Terminal X49/3 Low Voltage	0.07 V	All set-ups	TRUE	-2	Int16
36-21	Terminal X49/3 Low Current	4.00 mA	All set-ups	TRUE	-5	Int16
36-22	Terminal X49/3 High Voltage	10.00 V	All set-ups	TRUE	-2	Int16
36-23	Terminal X49/3 High Current	20.00 mA	All set-ups	TRUE	-5	Int16
36-24	Term. X49/3 Low Ref./Feedb. Value	0.000 N/A	All set-ups	TRUE	-3	Int32
36-25	Term. X49/3 High Ref./Feedb. Value	100.000 N/A	All set-ups	TRUE	-3	Int32
36-26	Term. X49/3 Filter Time Constant	0.001 s	All set-ups	TRUE	-3	Uint16
36-27	Term. X49/3 Live Zero	[1] Enabled	All set-ups	TRUE	-	Uint8
36-3* Analog Input X49/5						
36-30	Terminal X49/5 Low Voltage	0.07 V	All set-ups	TRUE	-2	Int16
36-31	Terminal X49/5 Low Current	4.00 mA	All set-ups	TRUE	-5	Int16
36-32	Terminal X49/5 High Voltage	10.00 V	All set-ups	TRUE	-2	Int16
36-33	Terminal X49/5 High Current	20.00 mA	All set-ups	TRUE	-5	Int16
36-34	Term. X49/5 Low Ref./Feedb. Value	0.000 N/A	All set-ups	TRUE	-3	Int32
36-35	Term. X49/5 High Ref./Feedb. Value	100.000 N/A	All set-ups	TRUE	-3	Int32
36-36	Term. X49/5 Filter Time Constant	0.001 s	All set-ups	TRUE	-3	Uint16
36-37	Term. X49/5 Live Zero	[1] Enabled	All set-ups	TRUE	-	Uint8

Par. No. #	Parameter description	Default value	4-set-up	Change during operation	Conversion index	Type
36-4* Output X49/7						
36-40	Terminal X49/7 Analog Output	[0] No operation	All set-ups	TRUE	-	UInt8
36-41	Terminal X49/7 Digital Output	[0] No operation	All set-ups	TRUE	-	UInt8
36-42	Terminal X49/7 Min. Scale	0.00 %	All set-ups	TRUE	-2	Int16
36-43	Terminal X49/7 Max. Scale	100.00 %	All set-ups	TRUE	-2	Int16
36-44	Terminal X49/7 Bus Control	0.00 %	All set-ups	TRUE	-2	N2
36-45	Terminal X49/7 Timeout Preset	0.00 %	1 set-up	TRUE	-2	UInt16
36-5* Output X49/9						
36-50	Terminal X49/9 Analog Output	[0] No operation	All set-ups	TRUE	-	UInt8
36-51	Terminal X49/9 Digital Output	[0] No operation	All set-ups	TRUE	-	UInt8
36-52	Terminal X49/9 Min. Scale	0.00 %	All set-ups	TRUE	-2	Int16
36-53	Terminal X49/9 Max. Scale	100.00 %	All set-ups	TRUE	-2	Int16
36-54	Terminal X49/9 Bus Control	0.00 %	All set-ups	TRUE	-2	N2
36-55	Terminal X49/9 Timeout Preset	0.00 %	1 set-up	TRUE	-2	UInt16
36-6* Output X49/11						
36-60	Terminal X49/11 Analog Output	[0] No operation	All set-ups	TRUE	-	UInt8
36-61	Terminal X49/11 Digital Output	[0] No operation	All set-ups	TRUE	-	UInt8
36-62	Terminal X49/11 Min. Scale	0.00 %	All set-ups	TRUE	-2	Int16
36-63	Terminal X49/11 Max. Scale	100.00 %	All set-ups	TRUE	-2	Int16
36-64	Terminal X49/11 Bus Control	0.00 %	All set-ups	TRUE	-2	N2
36-65	Terminal X49/11 Timeout Preset	0.00 %	1 set-up	TRUE	-2	UInt16

Dedicated factory settings

Frequency converters delivered as part of a Trane equipment can have dedicated factory settings. Upon factory reset of the frequency converter these parameter settings will be used as default. See below for details on the specific equipment settings.

Trane IntelliPak™, IntelliPak™ II, and Voyager III™		
Par. No. #	Parameter description	Trane default value
0-01	Language	[22] English US
0-03	Regional Unit Settings	[1] North America
0-20	Display Line 1.1 Small	[1662] Analog Input 53
0-22	Display Line 1.3 Small	[1611] Power [hp]
0-40	Hand Start Button	[0] Disabled
1-03	Torque Characteristics	[1] Variable
1-21	Motor Power [HP]	Reference Motor Nameplate HP
1-22	Motor Voltage	Reference Motor Nameplate Voltage
1-24	Motor Current	Reference Motor Nameplate FLA
1-25	Motor Nominal Speed	Reference Motor Nameplate Rated Speed
1-73	Flying Start	[1] Enabled
2-00	DC Hold/Preheat Current	0%
2-01	DC Brake Current	0%
2-04	DC Brake Cut-in Speed [Hz]	10Hz
3-41	Ramp 1 Ramp-up Time	30 Sec.
3-42	Ramp-down Time	30 Sec.
4-12	Motor Speed Low Limit [Hz]	22 Hz IntelliPak 35 Hz Voyager III
4-18	Current Limit	100%
5-12	Terminal 27, Digital Input	[2] Coast Inverse
6-14	Terminal 53 Low Ref./Feedb. Value	22 Hz IntelliPak 35 Hz Voyager III
14-01	Switching Frequency	208/203V, 30 Hp and below 8kHz, above 5 kHz 460/575V, 60 Hp and below 8 kHz, above 5 kHz
14-12	Function at Mains Imbalance	[3] Derate
14-20	Reset Mode	[3] Automatic reset x 3
14-60	Function at Overtemperature	[1] Derate
14-61	Function at Invertor Overload	[1] Derate

Trane M-Series and T-Series Climate Changer™, Performance Climate Changer™ - Indoor & Outdoor		
Par. No. #	Parameter description	Trane default value
0-03	Regional Unit Settings	[1] North America
1-21	Motor Power [HP]	Reference Motor Nameplate HP
1-22	Motor Voltage	Reference Motor Nameplate Voltage
1-24	Motor Current	Reference Motor Nameplate FLA
1-25	Motor Nominal Speed	Reference Motor Nameplate Rated Speed
1-73	Flying Start	[Enabled]
3-03	Maximum Reference	60 Hz or (for direct drive) Set for Application
3-41	Ramp 1 Ramp-up Time	30 Sec.
3-42	Ramp 1 Ramp-down Time	30 Sec.
4-12	Motor Speed Low Limit [Hz]	20 Hz
4-14	Motor Speed High Limit [Hz]	60 Hz or (for direct drive) Set for Application
5-12	Terminal 27 Digital Input	[2] Coast Inverse
6-14	Terminal 53 Low Ref./Feedb. Value	20 Hz
6-15	Terminal 53 High Ref./Feedb. Value	60 Hz or (for direct drive) Set for Application
14-01	Switching Frequency	208/230V, 30 Hp and below 8kHz, above 5 kHz 460/575V, 60 Hp and below 8 kHz, above 5 kHz

Trane Commercial Self Contained and Packaged Climate Changer™		
Par. No. #	Parameter description	Trane default value
0-01	Language	[22] English US
0-03	Regional Settings	[1] North America
0-22	Display Line 1.3 Small	[1611] Power [HP]
1-21	Motor Power [HP]	Reference Motor Nameplate HP
1-22	Motor Voltage	Reference Motor Nameplate Voltage
1-24	Motor Current	Reference Motor Nameplate FLA
1-25	Motor Nominal Speed	Reference Motor Nameplate Rated Speed
1-73	Flying Start	[1] Enabled
3-41	Ramp 1 Ramp-up Time	30 Sec.
3-42	Ramp 1 Ramp-down Time	30 Sec.
4-12	Motor Speed Low Limit [Hz]	22 Hz
5-12	Terminal 27, Digital Input	[2] Coast Inverse, Commercial Self Contained [0] No operation, Packaged Climate Changer
6-14	Terminal 53 Low Ref. / Feedb. Value	22 Hz
14-01	Switching Frequency	8 kHz
14-12	Function at Mains Imbalance	[3] Derate
14-21	Automatic Restart Time	3 Sec.
14-60	Function at Overtemperature	[1] Derate



How to program the Frequency Converter

Troubleshooting

Alarms and Warnings

A warning or an alarm is signalled by the relevant LED on the front of the frequency converter and indicated by a code on the display.

A warning remains active until its cause is no longer present. Under certain circumstances operation of the motor may still be continued. Warning messages may be critical, but are not necessarily so.

In the event of an alarm, the frequency converter will have tripped. Alarms must be reset to restart operation once their cause has been rectified.

This may be done in four ways:

1. By using the [RESET] control button on the keypad.
2. Via a digital input with the "Reset" function.
3. Via serial communication/optional fieldbus.
4. By resetting automatically using the [Auto Reset] function, which is a default setting for TR200 Drive, see par. 14-20 [Reset Mode](#) in the **TR200 Programming Guide**

After a manual reset using the [RESET] button on the keypad, the [AUTO ON] or [HAND ON] button must be pressed to restart the motor.

If an alarm cannot be reset, the reason may be that its cause has not been rectified, or the alarm is trip-locked (see also table on following page).

Alarms that are trip-locked offer additional protection, means that the mains supply must be switched off before the alarm can be reset. After being switched back on, the frequency converter is no longer blocked and may be reset as described above once the cause has been rectified.

Alarms that are not trip-locked can also be reset using the automatic reset function in par. 14-20 [Reset Mode](#) (Warning: automatic wake-up is possible!)

If a warning and alarm is marked against a code in the table on the following page, this means that either a warning occurs before an alarm, or it can be specified whether it is a warning or an alarm that is to be displayed for a given fault. This is possible, for instance, in par. 1-90 [Motor Thermal Protection](#). After an alarm or trip, the motor carries on coasting, and the alarm and warning flash on the frequency converter. Once the problem has been rectified, only the alarm continues flashing.

Alarms that are trip-locked offer additional protection, means that the mains supply must be switched off before the alarm can be reset. After being switched back on, the frequency converter is no longer blocked and may be reset as described above once the cause has been rectified.

Alarms that are not trip-locked can also be reset using the automatic reset function in par. 14-20 [Reset Mode](#)

Automatic wake-up is possible!

Could result in equipment or property damage.

If a warning and alarm is marked against a code in the table on the following page, this means that either a warning occurs before an alarm, or it can be specified whether it is a warning or an alarm that is to be displayed for a given fault.

This is possible, for instance, in par. 1-90 [Motor Thermal Protection](#). After an alarm or trip, the motor carries on coasting, and the alarm and warning flash on the frequency converter. Once the problem has been rectified, only the alarm continues flashing.

No.	Description	Warning	Alarm/ Trip	Alarm/Trip Lock	Parameter Reference
1	10 Volts low	X			
2	Live zero error	(X)	(X)		6-01
3	No motor	(X)			1-80
4	Mains phase loss	(X)	(X)	(X)	14-12
5	DC link voltage high	X			
6	DC link voltage low	X			
7	DC over voltage	X	X		
8	DC under voltage	X	X		
9	Inverter overloaded	X	X		
10	Motor ETR over temperature	(X)	(X)		1-90
11	Motor thermistor over temperature	(X)	(X)		1-90
12	Torque limit	X	X		
13	Over Current	X	X	X	
14	Earth fault	X	X	X	
15	Hardware mismatch		X	X	
16	Short Circuit		X	X	
17	Control word timeout	(X)	(X)		8-04
23	Internal Fan Fault	X			
24	External Fan Fault	X			14-53
25	Brake resistor short-circuited	X			
26	Brake resistor power limit	(X)	(X)		2-13
27	Brake chopper short-circuited	X	X		
28	Brake check	(X)	(X)		2-15
29	Drive over temperature	X	X	X	
30	Motor phase U missing	(X)	(X)	(X)	4-58
31	Motor phase V missing	(X)	(X)	(X)	4-58
32	Motor phase W missing	(X)	(X)	(X)	4-58
33	Inrush fault		X	X	
34	Fieldbus communication fault	X	X		
35	Out of frequency range	X	X		
36	Mains failure	X	X		
37	Phase Imbalance	X	X		
38	Internal fault		X	X	
39	Heatsink sensor		X	X	
40	Overload of Digital Output Terminal 27	(X)			5-01
41	Overload of Digital Output Terminal 29	(X)			5-02
42	Overload of Digital Output On X30/6	(X)			5-32
42	Overload of Digital Output On X30/7	(X)			5-33
46	Pwr. card supply		X	X	
47	24 V supply low	X	X	X	
48	1.8 V supply low		X	X	
49	Speed limit	X	(X)		1-86
50	AMA calibration failed		X		
51	AMA check U_{nom} and I_{nom}		X		
52	AMA low I_{nom}		X		
53	AMA motor too big		X		
54	AMA motor too small		X		
55	AMA Parameter out of range		X		
56	AMA interrupted by user		X		
57	AMA timeout		X		
58	AMA internal fault	X	X		

No.	Description	Warning	Alarm/ Trip	Alarm/Trip Lock	Parameter Reference
59	Current limit	X			
60	External Interlock	X			
62	Output Frequency at Maximum Limit	X			
64	Voltage Limit	X			
65	Control Board Over-temperature	X	X	X	
66	Heat sink Temperature Low	X			
67	Option Configuration has Changed		X		
69	Pwr. Card Temp		X	X	
70	Illegal FC configuration			X	
72	Dangerous Failure			X ¹⁾	
76	Power Unit Setup	X			
79	Illegal PS config		X	X	
80	Drive Initialized to Default Value		X		
91	Analog input 54 wrong settings			X	
92	NoFlow	X	X		22-2*
93	Dry Pump	X	X		22-2*
94	End of Curve	X	X		22-5*
95	Broken Belt	X	X		22-6*
96	Start Delayed	X			22-7*
97	Stop Delayed	X			22-7*
98	Clock Fault	X			0-7*
201	Fire M was Active				
202	Fire M Limits Exceeded				
203	Missing Motor				
204	Locked Rotor				
243	Brake IGBT	X	X		
244	Heatsink temp	X	X	X	
245	Heatsink sensor		X	X	
246	Pwr.card supply		X	X	
247	Pwr.card temp		X	X	
248	Illegal PS config		X	X	
250	New spare parts			X	
251	Type Code		X	X	

Table 7. 1: Alarm/Warning code list

(X) Dependent on parameter

1) Can not be Auto reset via par. 14-20 [Reset Mode](#)

A trip is the action when an alarm has appeared. The trip will coast the motor and can be reset by pressing the reset button or make a reset by a digital input (parameter group 5-1* [1]). The original event that caused an alarm cannot damage the frequency converter or cause dangerous conditions. A trip lock is an action when an

alarm occurs, which may cause damage to frequency converter or connected parts. A Trip Lock situation can only be reset by a power cycling.

<i>LED indication</i>	
Warning	yellow
Alarm	flashing red
Trip locked	yellow and red

Table 7. 2: LED Indication

Alarm Word and Extended Status Word					
Bit	Hex	Dec	Alarm Word	Warning Word	Extended Status Word
0	00000001	1	Brake Check	Brake Check	Ramping
1	00000002	2	Pwr. Card Temp	Pwr. Card Temp	AMA Running
2	00000004	4	Earth Fault	Earth Fault	Start CW/CCW
3	00000008	8	Ctrl.Card Temp	Ctrl.Card Temp	Slow Down
4	00000010	16	Ctrl. Word TO	Ctrl. Word TO	Catch Up
5	00000020	32	Over Current	Over Current	Feedback High
6	00000040	64	Torque Limit	Torque Limit	Feedback Low
7	00000080	128	Motor Th Over	Motor Th Over	Output Current High
8	00000100	256	Motor ETR Over	Motor ETR Over	Output Current Low
9	00000200	512	Inverter Overld.	Inverter Overld.	Output Freq High
10	00000400	1024	DC under Volt	DC under Volt	Output Freq Low
11	00000800	2048	DC over Volt	DC over Volt	Brake Check OK
12	00001000	4096	Short Circuit	DC Voltage Low	Braking Max
13	00002000	8192	Inrush Fault	DC Voltage High	Braking
14	00004000	16384	Mains ph. Loss	Mains ph. Loss	Out of Speed Range
15	00008000	32768	AMA Not OK	No Motor	OVC Active
16	00010000	65536	Live Zero Error	Live Zero Error	
17	00020000	131072	Internal Fault	10V Low	
18	00040000	262144	Brake Overload	Brake Overload	
19	00080000	524288	U phase Loss	Brake Resistor	
20	00100000	1048576	V phase Loss	Brake IGBT	
21	00200000	2097152	W phase Loss	Speed Limit	
22	00400000	4194304	Fieldbus Fault	Fieldbus Fault	
23	00800000	8388608	24 V Supply Low	24V Supply Low	
24	01000000	16777216	Mains Failure	Mains Failure	
25	02000000	33554432	1.8V Supply Low	Current Limit	
26	04000000	67108864	Brake Resistor	Low Temp	
27	08000000	134217728	Brake IGBT	Voltage Limit	
28	10000000	268435456	Option Change	Unused	
29	20000000	536870912	Drive Initialized	Unused	

Table 7. 3: Description of Alarm Word, Warning Word and Extended Status Word

The alarm words, warning words and extended status words can be read out via serial bus or optional fieldbus for diagnosis. See also par. 16-90 [Alarm Word](#), par. 16-92 [Warning Word](#) and par. 16-94 [Ext. Status Word](#).

Fault Messages

WARNING

Hazardous Service Procedures!

The maintenance and troubleshooting procedures recommended in this section of the manual could result in exposure to electrical, mechanical or other potential safety hazards. Always refer to the safety warnings provided throughout this manual concerning these procedures. Unless specified otherwise, disconnect all electrical power including remote disconnect and discharge all energy storing devices such as capacitors before servicing. Follow proper lockout/tagout procedures to ensure the power can not be inadvertently energized. When necessary to work with live electrical components, have a qualified licensed electrician or other individual who has been trained in handling live electrical components perform these tasks. Failure to follow all of the recommended safety warnings provided, could result in death or serious injury.

WARNING 1, 10 volts low

The control card voltage is below 10 V from terminal 50.

Remove some of the load from terminal 50, as the 10 V supply is overloaded. Max. 15 mA or minimum 590 Ω .

This condition can be caused by a short in a connected potentiometer or improper wiring of the potentiometer.

WARNING

Live Electrical Components!

Troubleshooting: Remove the wiring from terminal 50. If the warning clears, the problem is with the customer wiring. If the warning does not clear, replace the control card.

WARNING/ALARM 2, Live zero error

This warning or alarm will only appear if programd by the user in par. 6-01 [Live Zero Timeout Function](#). The signal on one of the analog inputs is less than 50% of the minimum value programd for that input. This condition can be caused by broken wiring or faulty device sending the signal.

WARNING/ALARM 3, No motor

No motor has been connected to the output of the frequency converter. This warning or alarm will only appear if programd by the user in par. 1-80 [Function at Stop](#).

Troubleshooting: Check the connection between the drive and the motor.

WARNING/ALARM 4, Mains phase loss A phase is missing on the supply side, or the mains voltage imbalance is too high. This message also appears for a fault in the input rectifier on the frequency converter. Options are programd at par. 14-12 [Function at Mains Imbalance](#).

WARNING

Live Electrical Components!

Troubleshooting: Check the supply voltage and supply currents to the frequency converter.

WARNING 5, DC link voltage high

The intermediate circuit voltage (DC) is higher than the high voltage warning limit. The limit is dependent on the drive voltage rating. The frequency converter is still active.

WARNING 6, DC link voltage low

The intermediate circuit voltage (DC) is lower than the low voltage warning limit. The limit is dependent on the drive voltage rating. The frequency converter is still active.

WARNING/ALARM 7, DC overvoltage

If the intermediate circuit voltage exceeds the limit, the frequency converter trips after a time.

Troubleshooting:

Extend the ramp time

Change the ramp type

Activate functions in par. 2-10 [Brake Function](#)

Increase par. 14-26 [Trip Delay at Inverter Fault](#)

WARNING/ALARM 8, DC under voltage

If the intermediate circuit voltage (DC) drops below the under voltage limit, the frequency converter checks if a 24 V backup supply is connected. If no 24 V backup supply is connected, the frequency converter trips after a fixed time delay. The time delay varies with unit size.

WARNING/ALARM 9, Inverter overloaded

The frequency converter is about to cut out because of an overload (too high current for too long). The counter for electronic, thermal inverter protection gives a warning at 98% and trips at 100%, while giving an alarm. The frequency converter *cannot* be reset until the counter is below 90%.

The fault is that the frequency converter is overloaded by more than 100% for too long. NOTE: See the derating section in the Design Guide for more details if a high switching frequency is required.

WARNING/ALARM 10, Motor overload temperature

According to the electronic thermal protection (ETR), the motor is too hot. Select whether the frequency converter gives a warning or an alarm when the counter reaches 100% in par. 1-90 [Motor Thermal Protection](#). The fault is that the motor is overloaded by more than 100% for too long.

 **WARNING**

Live Electrical Components!

Troubleshooting:

Check if motor is over heating.

If the motor is mechanically overloaded

That the motor par. 1-24 [Motor Current](#) is set correctly.

Motor data in parameters 1-20 through 1-25 are set correctly.

The setting in par. 1-91 [Motor External Fan](#).

Run AMA in par. 1-29 [Automatic Motor Adaptation \(AMA\)](#).

 **WARNING**

Disconnect power before proceeding.

WARNING/ALARM 12, Torque limit

The torque is higher than the value in par. 4-16 [Torque Limit Motor Mode](#) or the torque is higher than the value in par. 4-17 [Torque Limit Generator Mode](#).

Par. 14-25 [Trip Delay at Torque Limit](#) can be used to change this from a warning only condition to a warning followed by an alarm.

WARNING/ALARM 13, Over current

The inverter peak current limit (approx. 200% of the rated current) is exceeded. The warning lasts about 1.5 sec., then the frequency converter trips and issues an alarm. If extended mechanical brake control is selected, trip can be reset externally.

Troubleshooting:

This fault may be caused by shock loading or fast acceleration with high inertia loads.

Turn off the frequency converter. Check if the motor shaft can be turned.

Check that the motor size matches the frequency converter.

Incorrect motor data in parameters 1-20 through 1-25.

ALARM 14, Earth (ground) fault

There is a discharge from the output phases to earth, either in the cable between the frequency converter and the motor or in the motor itself.

 **WARNING**

Disconnect power before proceeding.

Troubleshooting:

Turn off the frequency converter and remove the earth fault.

Measure the resistance to ground of the motor leads and the motor with a megohmmeter to check for earth faults in the motor.

Perform current sensor test.

ALARM 15, Hardware mismatch

A fitted option is not operational with the present control board hardware or software.

Record the value of the following parameters and contact your Trane supplier:

Par. 15-40 [FC Type](#)

Par. 15-41 [Power Section](#)

Par. 15-42 [Voltage](#)

Par. 15-43 [Software Version](#)

Par. 15-45 [Actual Typecode String](#)

Par. 15-49 [SW ID Control Card](#)

Par. 15-50 [SW ID Power Card](#)

Par. 15-60 [Option Mounted](#)

Par. 15-61 [Option SW Version](#)

ALARM 16, Short circuit

There is short-circuiting in the motor or on the motor terminals.

⚠️ WARNING

Disconnect power before proceeding.

Turn off the frequency converter and remove the short-circuit.

WARNING/ALARM 17, Control word timeout

There is no communication to the frequency converter.

The warning will only be active when par. 8-04 [Control Timeout Function](#) is NOT set to OFF.

If par. 8-04 [Control Timeout Function](#) is set to *Stop* and *Trip*, a warning appears and the frequency converter ramps down until it trips, while giving an alarm.

⚠️ WARNING

Live Electrical Components!

Troubleshooting:

Check connections on the serial communication cable.

Increase par. 8-03 [Control Timeout Time](#)

Check operation of the communication equipment.

Verify proper installation based on EMC requirements.

WARNING 23, Internal fan fault

The fan warning function is an extra protection function that checks if the fan is running / mounted. The fan warning can be disabled in par. 14-53 [Fan Monitor](#) ([0] Disabled).

For the D, E, and F Frame drives, the regulated voltage to the fans is monitored.

⚠️ WARNING

Disconnect power before proceeding.

Troubleshooting:

Check fan resistance.

Check soft charge fuses.

WARNING 24, External fan fault

The fan warning function is an extra protection function that checks if the fan is running / mounted. The fan warning can be disabled in par. 14-53 [Fan Monitor](#) ([0] Disabled).

For the D, E, and F Frame drives, the regulated voltage to the fans is monitored.

Troubleshooting:

Check fan resistance.

Check soft charge fuses.

WARNING/ALARM 28, Brake check failed

Brake resistor fault: the brake resistor is not connected or not working.

Check par. 2-15 [Brake Check](#).

ALARM 29, Heatsink temp

The maximum temperature of the heatsink has been exceeded. The temperature fault will not be reset until the temperature falls below a defined heatsink temperature. The trip and reset point are different based on the drive power size.

Troubleshooting:

Ambient temperature too high.

Too long motor cable.

Incorrect clearance above and below the drive.

Dirty heatsink.

Blocked air flow around the drive.

Damaged heatsink fan.

For the D, E, and F Frame Drives, this alarm is based on the temperature measured by the heatsink sensor mounted inside the IGBT modules. For the F Frame drives, this alarm can also be caused by the thermal sensor in the Rectifier module.

⚠️ WARNING

Disconnect power before proceeding.

Troubleshooting:

Check fan resistance.

Check soft charge fuses.

IGBT thermal sensor.

ALARM 30, Motor phase U missing

Motor phase U between the frequency converter and the motor is missing.

WARNING

Disconnect power before proceeding.

Turn off the frequency converter and check motor phase U.

ALARM 31, Motor phase V missing

Motor phase V between the frequency converter and the motor is missing.

WARNING

Disconnect power before proceeding.

Turn off the frequency converter and check motor phase V.

ALARM 32, Motor phase W missing

Motor phase W between the frequency converter and the motor is missing.

WARNING

Disconnect power before proceeding.

Turn off the frequency converter and check motor phase W.

ALARM 33, Inrush fault

Too many power-ups have occurred within a short time period. Let unit cool to operating temperature.

WARNING/ALARM 34, Fieldbus communication fault

The fieldbus on the communication option card is not working.

WARNING/ALARM 35, Out of frequency range:

This warning is active if the output frequency has reached the high limit (set in par. 4-53) or low limit (set in par. 4-52). In *Process Control, Closed Loop* (par. 1-00) this warning is displayed.

WARNING/ALARM 36, Mains failure

This warning/alarm is only active if the supply voltage to the frequency converter is lost and par. 14-10 [Line Failure](#) is NOT set to OFF. Check the fuses to the frequency converter

ALARM 38, Internal fault

It may be necessary to contact your Trane supplier. Some typical alarm messages:

0	Serial port cannot be initialized. Serious hardware failure
256-258	Power EEPROM data is defect or too old
512	Control board EEPROM data is defect or too old
513	Communication time out reading EEPROM data
514	Communication time out reading EEPROM data
515	Application Orientated Control cannot recognize the EEPROM data
516	Cannot write to the EEPROM because a write command is on progress
517	Write command is under time out
518	Failure in the EEPROM
519	Missing or invalid Barcode data in EEPROM
783	Parameter value outside of min/max limits
1024-1279	A can-telegram that has to be sent, couldn't be sent
1281	Digital Signal Processor flash timeout
1282	Power micro software version mismatch
1283	Power EEPROM data version mismatch
1284	Cannot read Digital Signal Processor software version
1299	Option SW in slot A is too old
1300	Option SW in slot B is too old
1302	Option SW in slot C1 is too old
1315	Option SW in slot A is not supported (not allowed)
1316	Option SW in slot B is not supported (not allowed)
1318	Option SW in slot C1 is not supported (not allowed)
1379	Option A did not respond when calculating Platform Version.
1380	Option B did not respond when calculating Platform Version.
1536	An exception in the Application Orientated Control is registered. Debug information written in keypad
1792	DSP watchdog is active. Debugging of power part data Motor Orientated Control data not transferred correctly
2049	Power data restarted
2064-2072	H081x: option in slot x has restarted
2080-2088	H082x: option in slot x has issued a power-up-wait

2096-2 104	H083x: option in slot x has issued a legal powerup-wait
2304	Could not read any data from power EE-PROM
2305	Missing SW version from power unit
2314	Missing power unit data from power unit
2315	Missing SW version from power unit
2316	Missing io_statepage from power unit
2324	Power card configuration is determined to be incorrect at power up
2330	Power size information between the power cards does not match
2561	No communication from DSP to ATACD
2562	No communication from ATACD to DSP (state running)
2816	Stack overflow Control board module
2817	Scheduler slow tasks
2818	Fast tasks
2819	Parameter thread
2820	keypad Stack overflow
2821	Serial port overflow
2822	USB port overflow
2836	cfListMempool to small
3072-5 122	Parameter value is outside its limits
5123	Option in slot A: Hardware incompatible with Control board hardware
5124	Option in slot B: Hardware incompatible with Control board hardware
5125	Option in slot C0: Hardware incompatible with Control board hardware
5126	Option in slot C1: Hardware incompatible with Control board hardware
5376-6 231	Out of memory

ALARM 39, Heatsink sensor

No feedback from the heatsink temperature sensor.

The signal from the IGBT thermal sensor is not available on the power card. The problem could be on the power card, on the gate drive card, or the ribbon cable between the power card and gate drive card.

WARNING 40, Overload of Digital Output Terminal 27

Check the load connected to terminal 27 or remove short-circuit connection. Check par. 5-01 [Terminal 27 Mode](#).

WARNING 41, Overload of Digital Output Terminal 29

Check the load connected to terminal 29 or remove short-circuit connection. Check par. 5-02 [Terminal 29 Mode](#).

WARNING 42, Overload of Digital Output on X30/6 or Overload of Digital Output on X30/7

For X30/6, check the load connected to X30/6 or remove short-circuit connection. Check par. 5-32 [Term X30/6 Digi Out \(MCB 101\)](#).

For X30/7, check the load connected to X30/7 or remove short-circuit connection. Check par. 5-33 [Term X30/7 Digi Out \(MCB 101\)](#).

ALARM 46, Power card supply

The supply on the power card is out of range.

There are three power supplies generated by the switch mode power supply (SMPS) on the power card: 24 V, 5V, +/- 18V. When powered with three phase mains voltage, all three supplied are monitored.

WARNING 47, 24 V supply low

The 24 Vdc is measured on the control card.

WARNING 48, 1.8 V supply low

The 1.8 Vdc supply used on the control card is outside of allowable limits. The power supply is measured on the control card.

WARNING 49, Speed limit

When the speed is not within the specified range in par. 4-11 and par. 4-13. the drive will show a warning. When the speed is below the specified limit in par. 1-86 [Trip Speed Low \[RPM\]](#) (except when starting or stopping) the drive will trip.

ALARM 50, AMA calibration failed

Contact your Trane supplier.

ALARM 51, AMA check Unom and Inom

The setting of motor voltage, motor current, and motor power is presumably wrong. Check the settings.

ALARM 52, AMA low Inom

The motor current is too low. Check the settings.

ALARM 53, AMA motor too big

The motor is too big for the AMA to be carried out.

ALARM 54, AMA motor too small

The motor is too small for the AMA to be carried out.

ALARM 55, AMA Parameter out of range

The parameter values found from the motor are outside acceptable range.

ALARM 56, AMA interrupted by user

The AMA has been interrupted by the user.

ALARM 57, AMA timeout

Try to start the AMA again a number of times, until the AMA is carried out. Please note that repeated runs may heat the motor to a level where the resistance Rs

and Rr are increased. In most cases, however, this is not critical.

ALARM 58, AMA internal fault

Contact your Trane supplier.

WARNING 59, Current limit

The current is higher than the value in par. 4-18 [Current Limit](#).

WARNING 60, External interlock

External interlock has been activated. To resume normal operation, apply 24 Vdc to the terminal programd for external interlock and reset the frequency converter (via serial communication, digital I/O, or by pressing reset button on keypad).

WARNING 62, Output frequency at maximum limit

The output frequency is higher than the value set in par. 4-19 [Max Output Frequency](#)

WARNING 64, Voltage limit

The load and speed combination demands a motor voltage higher than the actual DC link voltage.

WARNING/ALARM/TRIP 65, Control card over temperature

Control card over temperature: The cutout temperature of the control card is 80° C.

WARNING 66, Heatsink temperature low

This warning is based on the temperature sensor in the IGBT module.

Troubleshooting:

ALARM 67, Option module configuration has changed

One or more options have either been added or removed since the last power-down.

ALARM 69, Power card temperature

The temperature sensor on the power card is either too hot or too cold.

Troubleshooting:

Check the operation of the door fans.

Check that the filters for the door fans are not blocked.

Check that the gland plate is properly installed on IP 21 and IP 54 (NEMA 1 and NEMA 12) drives.

ALARM 70, Illegal Drive Configuration

Actual combination of control board and power board is illegal.

WARNING 76, Power Unit Setup

The required number of power units does not match the detected number of active power units.

WARNING 77, Reduced power mode:

This warning indicates that the drive is operating in reduced power mode (i.e. less than the allowed number of inverter sections). This warning will be generated on power cycle when the drive is set to run with fewer inverters and will remain on.

ALARM 79, Illegal power section configuration

The scaling card is the incorrect part number or not installed. Also MK102 connector on the power card could not be installed.

ALARM 80, Drive initialized to default value

Parameter settings are initialized to default settings after a manual reset.

ALARM 91, Analog input 54 wrong settings

Switch S202 has to be set in position OFF (voltage input) when a KTY sensor is connected to analog input terminal 54.

ALARM 92, No flow

A no-load situation has been detected in the system. See parameter group 22-2.

ALARM 93, Dry pump

A no-flow situation and high speed indicates that the pump has run dry. See parameter group 22-2.

ALARM 94, End of curve

Feedback stays lower than the set point which may indicate leakage in the pipe system.

ALARM 95, Broken belt

Torque is below the torque level set for no load, indicating a broken belt. See parameter group 22-6.

ALARM 96, Start delayed

Motor start has been delayed due to short-cycle protection active. See parameter group 22-7.

WARNING 97, Stop delayed

Stopping the motor has been delayed due to short cycle protection is active. See parameter group 22-7.

WARNING 98, Clock fault

Clock Fault. Time is not set or RTC clock (if mounted) has failed. See parameter group 0-7.

WARNING 201, Fire Mode was Active

Fire Mode has been active.

WARNING 202, Fire Mode Limits Exceeded

Fire Mode has suppressed one or more warranty voiding alarms.

WARNING 203, Missing Motor

A multi-motor under-load situation was detected, this could be due to e.g. a missing motor.

WARNING 204, Locked Rotor

A multi-motor overload situation was detected, this could be due to e.g. a locked rotor.

ALARM 244, Heatsink temperature

This alarm is only for F Frame drives. It is equivalent to Alarm 29. The report value in the alarm log indicates which power module generated the alarm:

- 1 = left most inverter module.
- 2 = middle inverter module in F2 or F4 drive.
- 2 = right inverter module in F1 or F3 drive.
- 3 = right inverter module in F2 or F4 drive.
- 5 = rectifier module.

ALARM 245, Heatsink sensor

This alarm is only for F Frame drives. It is equivalent to Alarm 39. The report value in the alarm log indicates which power module generated the alarm:

- 1 = left most inverter module.
- 2 = middle inverter module in F2 or F4 drive.
- 2 = right inverter module in F1 or F3 drive.
- 3 = right inverter module in F2 or F4 drive.
- 5 = rectifier module.

ALARM 246, Power card supply

This alarm is only for F Frame drives. It is equivalent to Alarm 46. The report value in the alarm log indicates which power module generated the alarm:

- 1 = left most inverter module.
- 2 = middle inverter module in F2 or F4 drive.
- 2 = right inverter module in F1 or F3 drive.
- 3 = right inverter module in F2 or F4 drive.
- 5 = rectifier module.

ALARM 247, Power card temperature

This alarm is only for F Frame drives. It is equivalent to Alarm 69. The report value in the alarm log indicates which power module generated the alarm:

- 1 = left most inverter module.
- 2 = middle inverter module in F2 or F4 drive.
- 2 = right inverter module in F1 or F3 drive.
- 3 = right inverter module in F2 or F4 drive.
- 5 = rectifier module.

ALARM 248, Illegal power section configuration

This alarm is only for F Frame drives. It is equivalent to Alarm 79. The report value in the alarm log indicates which power module generated the alarm:

- 1 = left most inverter module.
- 2 = middle inverter module in F2 or F4 drive.
- 2 = right inverter module in F1 or F3 drive.
- 3 = right inverter module in F2 or F4 drive.
- 5 = rectifier module.

ALARM 250, New spare part

The power or switch mode power supply has been exchanged. The frequency converter type code must be restored in the EEPROM. Select the correct type code in par. 14-23 [Typecode Setting](#) according to the label on the unit. Remember to select 'Save to EEPROM' to complete.

ALARM 251, New type code

The frequency converter has a new type code.

Acoustic Noise or Vibration

If the motor or the equipment driven by the motor - e.g. a fan blade - is making noise or vibrations at certain frequencies, try the following:

- Speed Bypass, parameter group 4-6*
- Over-modulation, par. 14-03 [Overmodulation](#) set to off
- Switching pattern and -frequency parameter group 14-0*
- Resonance Dampening, par. 1-64 [Resonance Dampening](#)

Specifications

General Specifications

Mains supply 200 - 240 VAC - Normal overload 110% for 1 minute						
Frequency converter	P1K1	P1K5	P2K2	P3K0	P3K7	
Typical Shaft Output [kW]	1.1	1.5	2.2	3	3.7	
IP 20 / Chassis						
(A2+A3 may be converted to IP21 using a conversion kit. (Please see also items <i>Mechanical mounting</i> in Operating Instructions and <i>IP 21/Type 1 Enclosure kit</i> in the Design Guide.))	A2	A2	A2	A3	A3	
IP 55 / NEMA 12						
IP 66 / NEMA 12						
Typical Shaft Output [HP] at 208 V	1.5	2.0	2.9	4.0	4.9	
Output current						
	Continuous (3 x 200-240 V) [A]	6.6	7.5	10.6	12.5	16.7
	Intermittent (3 x 200-240 V) [A]	7.3	8.3	11.7	13.8	18.4
	Continuous kVA (208 V AC) [kVA]	2.38	2.70	3.82	4.50	6.00
	Max. cable size:					
Max. input current						
	Continuous (3 x 200-240 V) [A]	5.9	6.8	9.5	11.3	15.0
	Intermittent (3 x 200-240 V) [A]	6.5	7.5	10.5	12.4	16.5
	Max. pre-fuses ¹⁾ [A]	20	20	20	32	32
	Environment					
	Estimated power loss at rated max. load [W] ⁴⁾	63	82	116	155	185
	Weight enclosure IP20 [kg]	4.9	4.9	4.9	6.6	6.6
	Weight enclosure IP21 [kg]	5.5	5.5	5.5	7.5	7.5
	Weight enclosure IP55 [kg]	9.7/13.5	9.7/13.5	9.7/13.5	13.5	13.5
	Weight enclosure IP 66 [kg]	9.7/13.5	9.7/13.5	9.7/13.5	13.5	13.5
	Efficiency ³⁾ (mains, motor, brake) [mm ² /AWG] ²⁾	0.96	0.96	0.96	0.96	0.96
			4/10			

Table 8. 1: Mains Supply 200 - 240 VAC

Mains supply 3 x 200 - 240 VAC - Normal overload 110% for 1 minute

IP 20 / Chassis	B3	B3	B3	B4	B4	C3	C3	C4	C4
(B3+4 and C3+4 may be converted to IP21 using a conversion kit. (Please see also items <i>Mechanical mounting</i> in Operating Instructions and <i>IP 21/Type 1 Enclosure kit</i> in the Design Guide.))	B3	B3	B3	B4	B4	C3	C3	C4	C4
IP 21 / NEMA 1	B1	B1	B1	B2	B2	C1	C1	C2	C2
IP 55 / NEMA 12	B1	B1	B1	B2	B2	C1	C1	C2	C2
IP 66 / NEMA 12	B1	B1	B1	B2	B2	C1	C1	C2	C2
Frequency converter	P5K5	P7K5	P11K	P15K	P18K	P22K	P30K	P37K	P45K
Typical Shaft Output [kW]	5.5	7.5	11	15	18.5	22	30	37	45
Typical Shaft Output [HP] at 208 V	7.5	10	15	20	25	30	40	50	60

Output current

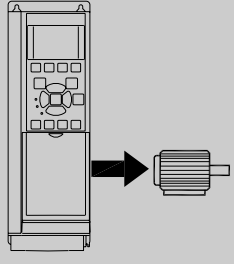
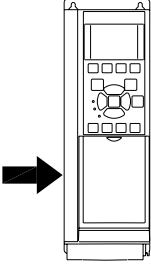
Continuous (3 x 200-240 V) [A]	24.2	30.8	46.2	59.4	74.8	88.0	115	143	170
	16/6		35/2	35/2		70/3/0	185/kcmil350		
Continuous (3 x 200-240 V) [A]	22.0	28.0	42.0	54.0	68.0	80.0	104.0	130.0	154.0
Intermittent (3 x 200-240 V) [A]	24.2	30.8	46.2	59.4	74.8	88.0	114.0	143.0	169.0
Max. pre-fuses ¹⁾ [A]	63	63	63	80	125	125	160	200	250
Environment:									
Estimated power loss at rated max. load [W] ⁴⁾	269	310	447	602	737	845	1140	1353	1636
Weight enclosure IP20 [kg]	12	12	12	23.5	23.5	35	35	50	50
Weight enclosure IP21 [kg]	23	23	23	27	45	45	45	65	65
Weight enclosure IP55 [kg]	23	23	23	27	45	45	45	65	65
Weight enclosure IP 66 [kg]	23	23	23	27	45	45	45	65	65
Efficiency ³⁾	0.96	0.96	0.96	0.96	0.96	0.97	0.97	0.97	0.97
Intermittent (3 x 200-240 V) [A]	26.6	33.9	50.8	65.3	82.3	96.8	127	157	187
Continuous kVA (208 V AC) [kVA]	8.7	11.1	16.6	21.4	26.9	31.7	41.4	51.5	61.2
Max. cable size: (mains, motor, brake) [mm ² /AWG] ²⁾		10/7		35/2		50/1/0 (B4=35/2)		95/4/0	120/250 MCM

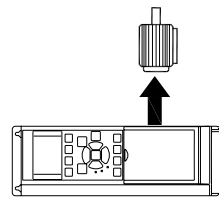

Table 8. 2: Mains Supply 3 x 200 - 240 VAC

Mains Supply 3 x 380 - 480 VAC - Normal overload 110% for 1 minute

Frequency converter	P1K1	P1K5	P2K2	P3K0	P4K0	P5K5	P7K5
Typical Shaft Output [kW]	1.1	1.5	2.2	3	4	5.5	7.5
Typical Shaft Output [HP] at 460 V	1.5	2.0	2.9	4.0	5.0	7.5	10
IP 20 / Chassis							
(A2+A3 may be converted to IP21 using a conversion kit. (Please see also items <i>Mechanical mounting</i> in Operating Instructions and <i>IP 21/Type 1 Enclosure kit</i> in the Design Guide.))	A2	A2	A2	A2	A2	A3	A3
IP 55 / NEMA 12	A4/A5	A4/A5	A4/A5	A4/A5	A4/A5	A5	A5
IP 66 / NEMA 12	A4/A5	A4/A5	A4/A5	A4/A5	A4/A5	A5	A5

Output current

Continuous (3 x 380-440 V) [A]	3	4.1	5.6	7.2	10	13	16
Intermittent (3 x 380-440 V) [A]	3.3	4.5	6.2	7.9	11	14.3	17.6
Continuous (3 x 441-480 V) [A]	2.7	3.4	4.8	6.3	8.2	11	14.5
Intermittent (3 x 441-480 V) [A]	3.0	3.7	5.3	6.9	9.0	12.1	15.4
Continuous kVA (400 V AC) [kVA]	2.1	2.8	3.9	5.0	6.9	9.0	11.0
Continuous kVA (460 V AC) [kVA]	2.4	2.7	3.8	5.0	6.5	8.8	11.6

Max. cable size:

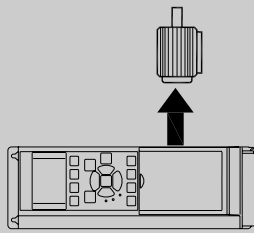

Max. input current

Continuous (3 x 380-440 V) [A]	2.7	3.7	5.0	6.5	9.0	11.7	14.4
Intermittent (3 x 380-440 V) [A]	3.0	4.1	5.5	7.2	9.9	12.9	15.8
Continuous (3 x 441-480 V) [A]	2.7	3.1	4.3	5.7	7.4	9.9	13.0
Intermittent (3 x 441-480 V) [A]	3.0	3.4	4.7	6.3	8.1	10.9	14.3
Max. pre-fuses ¹⁾ [A]	10	10	20	20	20	32	32
Environment							
Estimated power loss at rated max. load [W] ⁴⁾	58	62	88	116	124	187	255
Weight enclosure IP20 [kg]	4.8	4.9	4.9	4.9	4.9	6.6	6.6
Weight enclosure IP 21 [kg]							
Weight enclosure IP 55 [kg]	9.7/13.5	9.7/13.5	9.7/13.5	9.7/13.5	9.7/13.5	14.2	14.2
Weight enclosure IP 66 [kg]	9.7/13.5	9.7/13.5	9.7/13.5	9.7/13.5	9.7/13.5	14.2	14.2
Efficiency ³⁾	0.96	0.97	0.97	0.97	0.97	0.97	0.97
(mains, motor, brake) [[mm ² /AWG] ²⁾	4/10						

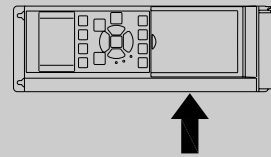

Table 8. 3: Mains Supply 3 x 380 - 480 VAC

Mains Supply 3 x 380 - 480 VAC - Normal overload 110% for 1 minute												
Frequency converter	P11K	P15K	P18K	P22K	P30K	P37K	P45K	P55K	P75K	P90K		
Typical Shaft Output [kW]	11	15	18.5	22	30	37	45	55	75	90		
Typical Shaft Output [HP] at 460 V	15	20	25	30	40	50	60	75	100	125		
IP 20 / Chassis												
(B3+4 and C3+4 may be converted to IP21 using a conversion kit (Please contact Trane))	B3	B3	B3	B4	B4	B4	C3	C3	C4	C4		
IP 21 / NEMA 1	B1	B1	B1	B2	B2	C1	C1	C1	C2	C2		
IP 55 / NEMA 12	B1	B1	B1	B2	B2	C1	C1	C1	C2	C2		
IP 66 / NEMA 12	B1	B1	B1	B2	B2	C1	C1	C1	C2	C2		
Output current												
Continuous (3 x 380-439 V) [A]	24	32	37.5	44	61	73	90	106	147	177		
Intermittent (3 x 380-439 V) [A]	26.4	35.2	41.3	48.4	67.1	80.3	99	117	162	195		
Continuous (3 x 440-480 V) [A]	21	27	34	40	52	65	80	105	130	160		
Intermittent (3 x 440-480 V) [A]	23.1	29.7	37.4	44	61.6	71.5	88	116	143	176		
Continuous kVA (400 V AC) [kVA]	16.6	22.2	26	30.5	42.3	50.6	62.4	73.4	102	123		
Continuous kVA (460 V AC) [kVA]	16.7	21.5	27.1	31.9	41.4	51.8	63.7	83.7	104	128		
Max. cable size:											185/	
With mains disconnect switch included:											70/3/0	35/2
Max. input current												
Continuous (3 x 380-439 V) [A]	22	29	34	40	55	66	82	96	133	161		
Intermittent (3 x 380-439 V) [A]	24.2	31.9	37.4	44	60.5	72.6	90.2	106	146	177		
Continuous (3 x 440-480 V) [A]	19	25	31	36	47	59	73	95	118	145		
Intermittent (3 x 440-480 V) [A]	20.9	27.5	34.1	39.6	51.7	64.9	80.3	105	130	160		
Max. pre-fuses ¹⁾ [A]	63	63	63	63	80	100	125	160	250	250		
Environment												
Estimated power loss at rated max. load [W] ⁴⁾	278	392	465	525	698	739	843	1083	1384	1474		
Weight enclosure IP20 [kg]	12	12	12	23.5	23.5	23.5	35	35	50	50		
Weight enclosure IP 21 [kg]	23	23	23	27	27	45	45	45	65	65		
Weight enclosure IP 55 [kg]	23	23	23	27	27	45	45	45	65	65		
Weight enclosure IP 66 [kg]	23	23	23	27	27	45	45	45	65	65		
Efficiency ³⁾	0.98	0.98	0.98	0.98	0.98	0.98	0.98	0.98	0.98	0.99		
(mains, motor, brake) [mm ² /AWG] ²⁾	10/7		35/2		50/1/0 (B4=35/2)		95/4/0		120/MCM250			

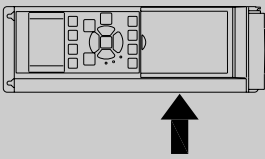
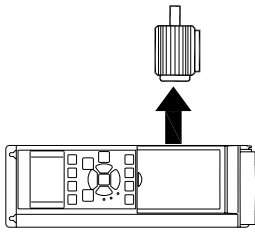
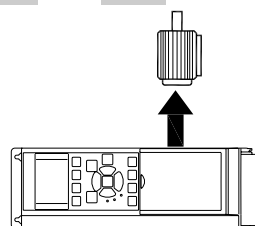

Table 8. 4: Mains Supply 3 x 380 - 480 VAC

Mains supply 3 x 525 - 600 VAC Normal overload 110% for 1 minute

Size:	P1K1	P1K5	P2K2	P3K0	P3K7	P4K0	P5K5	P7K5	P11K	P15K	P18K	P22K	P30K	P37K	P45K	P55K	P75K	P90K	
Typical Shaft Output [kW]	1.1	1.5	2.2	3	3.7	4	5.5	7.5	11	15	18.5	22	30	37	45	55	75	90	
IP 20 / Chassis	A3	A3	A3	A3	A2	A3	A3	A3	B3	B3	B3	B4	B4	B4	C3	C3	C4	C4	
IP 21 / NEMA 1	A3	A3	A3	A3	A2	A3	A3	A3	B1	B1	B1	B2	B2	C1	C1	C1	C2	C2	
IP 55 / NEMA 12	A5	A5	A5	A5	A5	A5	A5	A5	B1	B1	B1	B2	B2	C1	C1	C1	C2	C2	
IP 66 / NEMA 12	A5	A5	A5	A5	A5	A5	A5	A5	B1	B1	B1	B2	B2	C1	C1	C1	C2	C2	
Output current																			
Continuous (3 x 525-550 V) [A]	2.6	2.9	4.1	5.2	-	6.4	9.5	11.5	19	23	28	36	43	54	65	87	105	137	
Intermittent (3 x 525-550 V) [A]	2.9	3.2	4.5	5.7	-	7.0	10.5	12.7	21	25	31	40	47	59	72	96	116	151	
Continuous (3 x 525-600 V) [A]	2.4	2.7	3.9	4.9	-	6.1	9.0	11.0	18	22	27	34	41	52	62	83	100	131	
Intermittent (3 x 525-600 V) [A]	2.6	3.0	4.3	5.4	-	6.7	9.9	12.1	20	24	30	37	45	57	68	91	110	144	
Continuous kVA (525 V AC) [kVA]	2.5	2.8	3.9	5.0	-	6.1	9.0	11.0	18.1	21.9	26.7	34.3	41	51.4	61.9	82.9	100	130.5	
Continuous kVA (575 V AC) [kVA]	2.4	2.7	3.9	4.9	-	6.1	9.0	11.0	17.9	21.9	26.9	33.9	40.8	51.8	61.7	82.7	99.6	130.5	
Max. cable size, IP 21/55/66 (mains, motor, brake) [mm ²]/[AWG] ²⁾			4/ 10						10/ 7				25/ 4		50/ 1/0		120/ MCM 250		
Max. cable size, IP 20 (mains, motor, brake) [mm ²]/[AWG] ²⁾			4/ 10						16/ 6				35/ 2		50/ 1/0		150/ MCM 250 ⁵⁾		
With mains disconnect switch included:			4/10						16/6				35/2		70/3/ 0		185/ kcmil 350		

 Table 8. 5: ⁵⁾ With brake and load sharing 95/ 4/0

Mains supply 3 x 525 - 600 VAC Normal overload 110% for 1 minute - continued

Size:	P1K1	P1K5	P2K2	P3K0	P3K7	P4K0	P5K5	P7K5	P11K	P15K	P18K	P22K	P30K	P37K	P45K	P55K	P75K	P90K	
Max. input current																			
Continuous (3 x 525-600 V) [A]	2.4	2.7	4.1	5.2	-	5.8	8.6	10.4	17.2	20.9	25.4	32.7	39	49	59	78.9	95.3	124.3	
Intermittent (3 x 525-600 V) [A]	2.7	3.0	4.5	5.7	-	6.4	9.5	11.5	19	23	28	36	43	54	65	87	105	137	
Max. pre-fuses ¹⁾ [A]	10	10	20	20	-	20	32	32	63	63	63	63	80	100	125	160	250	250	
Environment:																			
Estimated power loss at rated max. load [W] ⁴⁾	50	65	92	122	-	145	195	261	300	400	475	525	700	750	850	1100	1400	1500	
Weight enclosure IP20 [kg]	6.5	6.5	6.5	6.5	-	6.5	6.6	6.6	12	12	12	23.5	23.5	23.5	35	35	50	50	
Weight enclosure IP21/55 [kg]	13.5	13.5	13.5	13.5	^{13.} ₅	13.5	14.2	14.2	23	23	23	27	27	27	45	45	65	65	
Efficiency ⁴⁾	0.97	0.97	0.97	0.97	-	0.97	0.97	0.97	0.98	0.98	0.98	0.98	0.98	0.98	0.98	0.98	0.98	0.98	

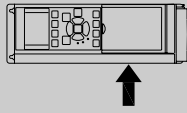

Table 8. 6: ⁵⁾ With brake and load sharing 95/ 4/0

Mains supply (L1, L2, L3):

Supply voltage	200-240 V ±10%, 380-480 V ±10%, 525-690 V ±10%
----------------	--

Mains voltage low / mains drop-out:

During low mains voltage or a mains drop-out, the FC continues until the intermediate circuit voltage drops below the minimum stop level, which corresponds typically to 15% below the FC's lowest rated supply voltage. Power-up and full torque cannot be expected at mains voltage lower than 10% below the FC's lowest rated supply voltage.

Supply frequency	50/60 Hz ±5%
------------------	--------------

Max. imbalance temporary between mains phases	3.0 % of rated supply voltage
---	-------------------------------

True Power Factor ()	≥ 0.9 nominal at rated load
-----------------------	-----------------------------

Displacement Power Factor (cos) near unity	(> 0.98)
--	----------

Switching on input supply L1, L2, L3 (power-ups) ≤ enclosure type A	maximum twice/min.
---	--------------------

Switching on input supply L1, L2, L3 (power-ups) ≥ enclosure type B, C	maximum once/min.
--	-------------------

Switching on input supply L1, L2, L3 (power-ups) ≥ enclosure type D, E, F	maximum once/2 min.
---	---------------------

Environment according to EN60664-1	overvoltage category III / pollution degree 2
------------------------------------	---

The unit is suitable for use on a circuit capable of delivering not more than 100.000 RMS symmetrical Amperes, 480/600 V maximum.

Motor output (U, V, W):

Output voltage	0 - 100% of supply voltage
----------------	----------------------------

Output frequency	0 - 1000 Hz*
------------------	--------------

Switching on output	Unlimited
---------------------	-----------

Ramp times	1 - 3600 sec.
------------	---------------

* Dependent on power size.

Torque characteristics:

Starting torque (Constant torque)	maximum 110% for 1 min.*
-----------------------------------	--------------------------

Starting torque	maximum 135% up to 0.5 sec.*
-----------------	------------------------------

Overload torque (Constant torque)	maximum 110% for 1 min.*
-----------------------------------	--------------------------

*Percentage relates to the frequency converter's nominal torque.

Cable lengths and cross sections:

Max. motor cable length, screened/armoured	TR200: 150 m
--	--------------

Max. motor cable length, unscreened/unarmoured	TR200: 300 m
--	--------------

Max. cross section to motor, mains, load sharing and brake *	
--	--

Maximum cross section to control terminals, rigid wire	1.5 mm ² /16 AWG (2 x 0.75 mm ²)
--	---

Maximum cross section to control terminals, flexible cable	1 mm ² /18 AWG
--	---------------------------

Maximum cross section to control terminals, cable with enclosed core	0.5 mm ² /20 AWG
--	-----------------------------

Minimum cross section to control terminals	0.25 mm ²
--	----------------------

* See Mains Supply tables for more information!

Digital inputs:

Programmable digital inputs	4 (6)
-----------------------------	-------

Terminal number	18, 19, 27 ¹⁾ , 29 ¹⁾ , 32, 33,
-----------------	---

Logic	PNP or NPN
-------	------------

Voltage level	0 - 24 Vdc
---------------	------------

Voltage level, logic '0' PNP	< 5 Vdc
------------------------------	---------

Voltage level, logic '1' PNP	> 10 Vdc
------------------------------	----------

Voltage level, logic '0' NPN	> 19 Vdc
------------------------------	----------

Voltage level, logic '1' NPN	< 14 Vdc
------------------------------	----------

Maximum voltage on input	28 Vdc
--------------------------	--------

Input resistance, R _i	approx. 4 kΩ
----------------------------------	--------------

All digital inputs are galvanically isolated from the supply voltage (PELV) and other high-voltage terminals.

1) Terminals 27 and 29 can also be programd as output.

Analog inputs:

Number of analog inputs	2
Terminal number	53, 54
Modes	Voltage or current
Mode select	Switch S201 and switch S202
Voltage mode	Switch S201/switch S202 = OFF (U)
Voltage level	: 0 to + 10 V (scaleable)
Input resistance, R_i	approx. 10 k Ω
Max. voltage	± 20 V
Current mode	Switch S201/switch S202 = ON (I)
Current level	0/4 to 20 mA (scaleable)
Input resistance, R_i	approx. 200 Ω
Max. current	30 mA
Resolution for analog inputs	10 bit (+ sign)
Accuracy of analog inputs	Max. error 0.5% of full scale
Bandwidth	: 200 Hz

The analog inputs are galvanically isolated from the supply voltage (PELV) and other high-voltage terminals.

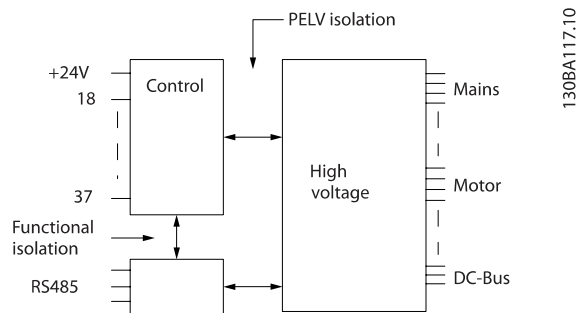

Pulse inputs:

Programmable pulse inputs	2
Terminal number pulse	29, 33
Max. frequency at terminal, 29, 33	110 kHz (Push-pull driven)
Max. frequency at terminal, 29, 33	5 kHz (open collector)
Min. frequency at terminal 29, 33	4 Hz
Voltage level	see section on Digital input
Maximum voltage on input	28 Vdc
Input resistance, R_i	approx. 4 k Ω
Pulse input accuracy (0.1 - 1 kHz)	Max. error: 0.1% of full scale

Analog output:

Number of programmable analog outputs	1
Terminal number	42
Current range at analog output	0/4 - 20 mA
Max. resistor load to common at analog output	500 Ω
Accuracy on analog output	Max. error: 0.8 % of full scale
Resolution on analog output	8 bit

The analog output is galvanically isolated from the supply voltage (PELV) and other high-voltage terminals.

Control card, RS-485 serial communication:

Terminal number	68 (P,TX+, RX+), 69 (N,TX-, RX-)
Terminal number 61	Common for terminals 68 and 69

The RS-485 serial communication circuit is functionally seated from other central circuits and galvanically isolated from the supply voltage (PELV).

Digital output:

Programmable digital/pulse outputs	2
Terminal number	27, 29 ¹⁾
Voltage level at digital/frequency output	0 - 24 V
Max. output current (sink or source)	40 mA
Max. load at frequency output	1 kΩ
Max. capacitive load at frequency output	10 nF
Minimum output frequency at frequency output	0 Hz
Maximum output frequency at frequency output	32 kHz
Accuracy of frequency output	Max. error: 0.1 % of full scale
Resolution of frequency outputs	12 bit

1) Terminal 27 and 29 can also be programd as input.

The digital output is galvanically isolated from the supply voltage (PELV) and other high-voltage terminals.

Control card, 24 Vdc output:

Terminal number	12, 13
Max. load	: 200 mA

The 24 Vdc supply is galvanically isolated from the supply voltage (PELV), but has the same potential as the analog and digital inputs and outputs.

Relay outputs:

Programmable relay outputs	2
Relay 01 Terminal number	1-3 (break), 1-2 (make)
Max. terminal load (AC-1) ¹⁾ on 1-3 (NC), 1-2 (NO) (Resistive load)	240 V AC, 2 A
Max. terminal load (AC-15) ¹⁾ (Inductive load @ cosφ 0.4)	240 Vac, 0.2 A
Max. terminal load (DC-1) ¹⁾ on 1-2 (NO), 1-3 (NC) (Resistive load)	60 Vdc, 1A
Max. terminal load (DC-13) ¹⁾ (Inductive load)	24 Vdc, 0.1A
Relay 02 Terminal number	4-6 (break), 4-5 (make)
Max. terminal load (AC-1) ¹⁾ on 4-5 (NO) (Resistive load) ²⁾³⁾	400 Vac, 2 A
Max. terminal load (AC-15) ¹⁾ on 4-5 (NO) (Inductive load @ cosφ 0.4)	240 Vac, 0.2 A
Max. terminal load (DC-1) ¹⁾ on 4-5 (NO) (Resistive load)	80 Vdc, 2 A
Max. terminal load (DC-13) ¹⁾ on 4-5 (NO) (Inductive load)	24 Vdc, 0.1A
Max. terminal load (AC-1) ¹⁾ on 4-6 (NC) (Resistive load)	240 Vac, 2 A
Max. terminal load (AC-15) ¹⁾ on 4-6 (NC) (Inductive load @ cosφ 0.4)	240 Vac, 0.2A
Max. terminal load (DC-1) ¹⁾ on 4-6 (NC) (Resistive load)	50 Vdc, 2 A
Max. terminal load (DC-13) ¹⁾ on 4-6 (NC) (Inductive load)	24 Vdc, 0.1 A
Min. terminal load on 1-3 (NC), 1-2 (NO), 4-6 (NC), 4-5 (NO)	24 Vdc 10 mA, 24 Vac 20 mA
Environment according to EN 60664-1	overvoltage category III/pollution degree 2

1) IEC 60947 t 4 and 5

The relay contacts are galvanically isolated from the rest of the circuit by reinforced isolation (PELV).

2) Overvoltage Category II

3) UL applications 300 Vac 2A

Control card, 10 V DC output:

Terminal number	50
Output voltage	10.5 V ±0.5 V
Max. load	25 mA

The 10 Vdc supply is galvanically isolated from the supply voltage (PELV) and other high-voltage terminals.

Control characteristics:

Resolution of output frequency at 0 - 1000 Hz	: +/- 0.003 Hz
System response time (terminals 18, 19, 27, 29, 32, 33)	: ≤ 2 ms
Speed control range (open loop)	1:100 of synchronous speed
Speed accuracy (open loop)	30 - 4000 rpm: Maximum error of ±8 rpm

All control characteristics are based on a 4-pole asynchronous motor

Surroundings:

Enclosure type A	IP 20/Chassis, IP 21kit/Type 1, IP55/Type12, IP 66/Type12
Enclosure type B1/B2	IP 21/Type 1, IP55/Type12, IP 66/12
Enclosure type B3/B4	IP20/Chassis
Enclosure type C1/C2	IP 21/Type 1, IP55/Type 12, IP66/12
Enclosure type C3/C4	IP20/Chassis
Enclosure type D1/D2/E1	IP21/Type 1, IP54/Type12
Enclosure type D3/D4/E2	IP00/Chassis
Enclosure type F1/F3	IP21, 54/Type1, 12
Enclosure type F2/F4	IP21, 54/Type1, 12
Enclosure kit available ≤ enclosure type D	IP21/NEMA 1/IP 4x on top of enclosure
Vibration test enclosure A, B, C	1.0 g
Vibration test enclosure D, E, F	0.7 g
Relative humidity	5% - 95% (IEC 721-3-3; Class 3K3 (non-condensing) during operation
Aggressive environment (IEC 60068-2-43) H ₂ S test	class Kd
Test method according to IEC 60068-2-43 H ₂ S (10 days)	
Ambient temperature (at 60 AVM switching mode)	
- with derating	max. 55° C ¹⁾
- with full output power of typical EFF2 motors (up to 90% output current)	max. 50° C ¹⁾
- at full continuous FC output current	max. 45° C ¹⁾
¹⁾ For more information on derating see the Design Guide, section on Special Conditions.	
Minimum ambient temperature during full-scale operation	0 °C
Minimum ambient temperature at reduced performance	- 10 °C
Temperature during storage/transport	-25 - +65/70 °C
Maximum altitude above sea level without derating	1000 m
Maximum altitude above sea level with derating	3000 m
<i>Derating for high altitude, see section on special conditions</i>	
EMC standards, Emission	EN 61800-3, EN 61000-6-3/4, EN 55011, IEC 61800-3 EN 61800-3, EN 61000-6-1/2,
EMC standards, Immunity	EN 61000-4-2, EN 61000-4-3, EN 61000-4-4, EN 61000-4-5, EN 61000-4-6
<i>See section on special conditions!</i>	
Control card performance:	
Scan interval	: 5 ms
Control card, USB serial communication:	
USB standard	1.1 (Full speed)
USB plug	USB type B "device" plug

Protection and Features:

- Electronic thermal motor protection against overload.
- Temperature monitoring of the heatsink ensures that the frequency converter trips if the temperature reaches 95 °C ± 5°C. An overload temperature cannot be reset until the temperature of the heatsink is below 70 °C ± 5°C (Guideline - these temperatures may vary for different power sizes, enclosures etc.). The frequency converter has an auto derating function to avoid it's heatsink reaching 95 deg C.
- The frequency converter is protected against short-circuits on motor terminals U, V, W.
- If a mains phase is missing, the frequency converter trips or issues a warning (depending on the load).
- Monitoring of the intermediate circuit voltage ensures that the frequency converter trips if the intermediate circuit voltage is too low or too high.
- The frequency converter is protected against earth faults on motor terminals U, V, W.

Special Conditions

Purpose of Derating

Derating must be taken into account when using the frequency converter at low air pressure (high altitudes), at low speeds, with long motor cables, cables with a large cross section or at high ambient temperature. The required action is described in this section.

Derating for Ambient Temperature

90% frequency converter output current can be maintained up to max. 50 °C ambient temperature.

With a typical full load current of EFF 2 motors, full output shaft power can be maintained up to 50 °C. For more specific data and/or derating information for other motors or conditions, please contact Trane.

The output current of frequency converters with build-in fuses installed in an environment with maximum ambient temperatures up to 50°C must be derated according to the table below.

		Maximum current at 50°C			
Mains Voltage		208-230V	380-440V	440-480V	525-600V
Motor power [hp]					
	1.0	4.1	2.2	1.9	1.5
	1.5	5.9	2.7	2.7	2.2
	2.0	6.8	3.7	3.1	2.4
	3.0	9.5	5.0	4.3	3.5
	5.0	15.0	9.0	7.4	
	7.5	22.2	11.7	9.9	
	10.0	28.0	14.4	13.1	
	15.0	41.6	21.6	18.9	
	20.0	55.0	-	25.0	

Automatic Adaptations to Ensure Performance

The frequency converter constantly checks for critical levels of internal temperature, load current, high voltage on the intermediate circuit and low motor speeds. As a response to a critical level, the frequency converter can adjust the switching frequency and / or change the switching pattern in order to ensure the performance of the frequency converter. The capability to automatically reduce the output current extends the acceptable operating conditions even further.

Derating for Low Air Pressure

The cooling capability of air is decreased at lower air pressure.

Below 1000 m altitude no derating is necessary but above 1000 m the ambient temperature (T_{AMB}) or max. output current (I_{out}) should be derated in accordance with the shown diagram.

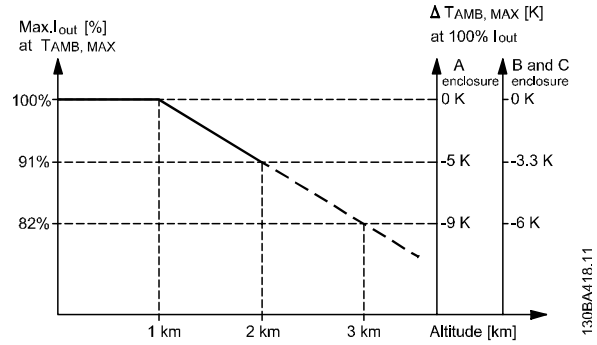
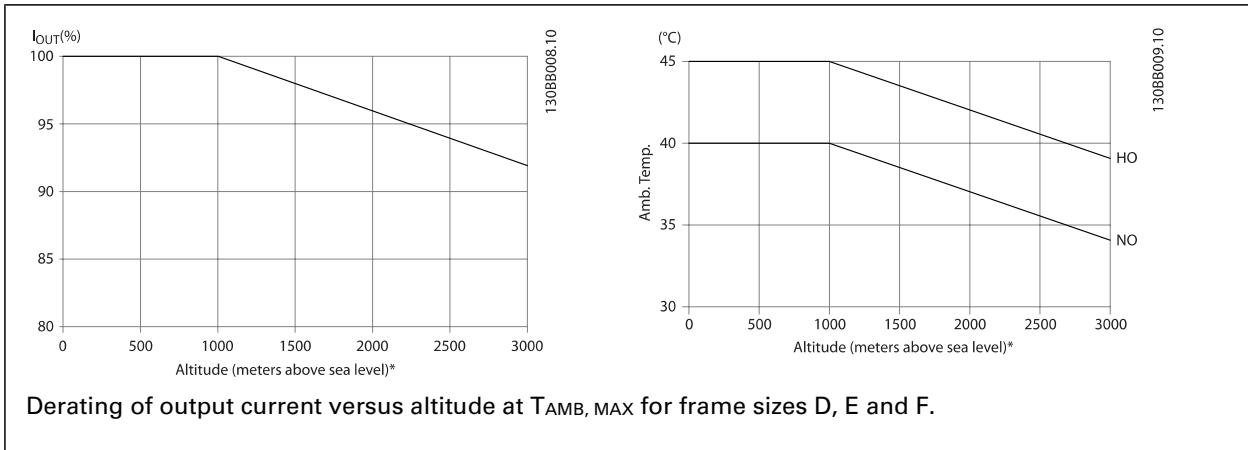

Figure 8. 1: Derating of output current versus altitude at $T_{AMB, MAX}$ for frame sizes A, B and C. At altitudes above 2 km, please contact Trane regarding PELV.

An alternative is to lower the ambient temperature at high altitudes and thereby ensure 100% output current at high altitudes. As an example of how to read the graph, the situation at 2 km is elaborated. At a temperature of 45° C ($T_{AMB, MAX} - 3.3$ K), 91% of the rated output current is available. At a temperature of 41.7° C, 100% of the rated output current is available.



Derating for Running at Low Speed

When a motor is connected to a frequency converter, it is necessary to check that the cooling of the motor is adequate.

The level of heating depends on the load on the motor, as well as the operating speed and time.

Constant torque applications (CT mode)

A problem may occur at low RPM values in constant torque applications. In a constant torque application a motor may over-heat at low speeds due to less cooling air from the motor integral fan.

Therefore, if the motor is to be run continuously at an RPM value lower than half of the rated value, the motor must be supplied with additional air-cooling (or a motor designed for this type of operation may be used).

An alternative is to reduce the load level of the motor by choosing a larger motor. However, the design of the frequency converter puts a limit to the motor size.

Variable (Quadratic) torque applications (VT)

In VT applications such as centrifugal pumps and fans, where the torque is proportional to the square of the speed and the power is proportional to the cube of the speed, there is no need for additional cooling or de-rating of the motor.

In the graphs shown below, the typical VT curve is below the maximum torque with de-rating and maximum torque with forced cooling at all speeds.

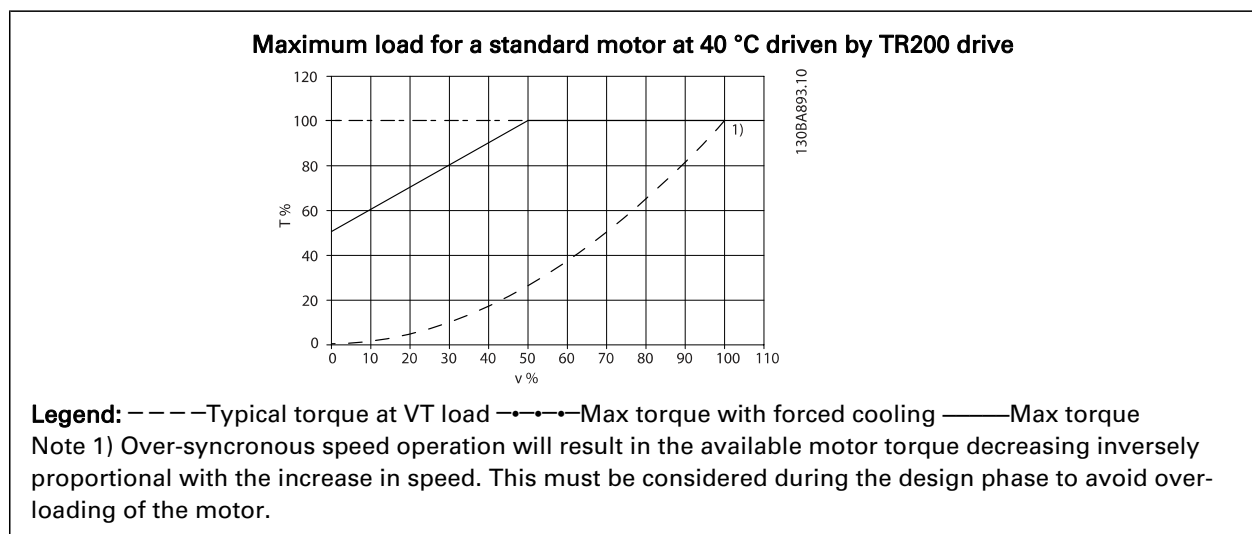

Index

A

Abbreviations And Standards	2-2
Ac Brake Max. Current 2-16.....	6-25
Acceleration Time	6-6
Access To Control Terminals	4-31
Accessory Bags	3-4
Alarm/warning Code List	7-3
Alarms And Warnings	7-1
Ama	5-10
Analog Inputs	8-8
Analog Output	8-8
Auto Energy Optimization Compressor	6-21
Auto Energy Optimization Vt	6-22
Auto Tune	4-36
Automatic Adaptations To Ensure Performance	8-11
Automatic Motor Adaptation (ama)	4-36, 6-22
Awg	8-1

B

Branch Circuit Protection	4-7
Broken Belt Delay 22-62.....	6-51
Broken Belt Function 22-60.....	6-51
Broken Belt Torque 22-61.....	6-51

C

Cable Lengths And Cross Sections	8-7
Changes Made	6-1
Changing A Group Of Numeric Data Values	6-57
Changing A Text Value	6-56
Changing Data	6-56
Changing Of Data Value	6-57
Changing Parameter Data	6-1
Checklist	3-1
Closed-loop Type 20-70.....	6-47
Coast Inverse	6-3
Coasting	5-5
Communication Option	7-8
Configuration Mode 1-00.....	6-21
Constant Torque Applications (ct Mode)	8-13
Control Cables	4-7
Control Cables	4-6
Control Card Performance	8-10
Control Card, 10 V Dc Output	8-9
Control Card, 24 Vdc Output	8-9
Control Card, Rs-485 Serial Communication:	8-8
Control Card, Usb Serial Communication:	8-10
Control Characteristics	8-9
Control Terminals	4-32
Cooling	6-24, 8-13
Cooling Conditions	3-5

D

Date Format 0-71.....	6-20
Dc Bus Connection	4-27
Dc Hold/preheat Current 2-00.....	6-25
Dc Link	7-5
Default Settings	6-58
Default Settings	5-11
Derating For Ambient Temperature	8-11

Derating For Low Air Pressure	8-12
Derating For Running At Low Speed	8-13
Digital Inputs:	8-7
Digital Output	8-9
Display Line 1.1 Small 0-20.....	6-15
Display Text 1 0-37.....	6-19
Display Text 2 0-38.....	6-20
Display Text 3 0-39.....	6-20
Disposal Instruction	1-5
Dst/summertime 0-74.....	6-20
Dst/summertime End 0-77.....	6-21
Dst/summertime Start 0-76.....	6-21

E

Earthing And It Mains	4-10
Electrical Installation	4-6
Electrical Ratings	1-4
Electronic Waste	1-5
Example Of Changing Parameter Data	6-1

F

Fault Messages	7-5
Feedback 1 Conversion 20-01.....	6-41
Feedback 1 Source 20-00.....	6-40
Feedback 1 Source Unit 20-02.....	6-41
Feedback 2 Conversion 20-04.....	6-43
Feedback 2 Source 20-03.....	6-43
Feedback 3 Conversion 20-07.....	6-43
Feedback Function 20-20.....	6-44
Final Optimization And Test	4-36
Flying Start 1-73.....	6-23
Frequency Converter	4-36
Frequency Converter Identification	2-3
Function At Stop 1-80.....	6-23
Function Relay 5-40.....	6-9, 6-32
Function Set-ups	6-11
Fuses	4-7
Fusing Not In UI Compliance	4-7

G

General Specifications	8-6
Graphical Display	5-1

H

High Power Series Mains And Motor Connections	4-4
How To Connect A Pc To The Frequency Converter	5-8
How To Connect Motor - Introduction	4-18
How To Connect To Mains And Earthing For B1 And B2	4-15
How To Operate Graphical	5-1

I

Indexed Parameters	6-57
Indicator Lights (leds)	5-3
Initialization	5-11
Installation At High Altitudes	1-3
Interval Between Starts 22-76.....	6-51

J

[Jog Speed Hz] 3-11.....	6-7
[Jog Speed Rpm] 3-19.....	6-7

L

Language 0-01.....	6-4
--------------------	-----

Language Package 1	6-4
Language Package 2	6-4
Leds	5-1
Literature	2-1
Live Zero Timeout Function 6-01	6-34
Live Zero Timeout Time 6-00	6-33
Loggings	6-1
Low Speed Detection 22-22	6-49

M

Main Menu	6-55
Main Menu Mode	5-4
Main Menu Mode	6-56
Main Reactance	6-22
Mains Connection For A2 And A3	4-12
Mains Connection For B1, B2 And B3	4-15
Mains Connection For B4, C1 And C2	4-16
Mains Connection For C3 And C4	4-17
Mains Supply	8-1, 8-4
Maximum Boost Time 22-46	6-51
Maximum Feedback Level 20-74	6-47
Maximum Reference 3-03	6-26
Maximum Reference/feedb. 20-14	6-44
Mechanical Dimensions	3-3
Mechanical Mounting	3-5
Minimum Feedback Level 20-73	6-47
Minimum Reference 3-02	6-26
Minimum Reference/feedb. 20-13	6-43
Minimum Run Time 22-40	6-50, 6-52
Minimum Sleep Time 22-41	6-50
Motor Connection For C3 And C4	4-24
Motor Current 1-24	6-5
Motor Frequency 1-23	6-5
Motor Name Plate	4-36
Motor Nominal Speed 1-25	6-5
Motor Output	8-7
[Motor Power Hp] 1-21	6-5
[Motor Power Kw] 1-20	6-5
Motor Protection	6-23, 8-10
Motor Rotation Check 1-28	6-6
Motor Speed Direction 4-10	6-28
[Motor Speed High Limit Hz] 4-14	6-7
[Motor Speed High Limit Rpm] 4-13	6-7
[Motor Speed Low Limit Hz] 4-12	6-7
[Motor Speed Low Limit Rpm] 4-11	6-6
Motor Thermal Protection 1-90	6-23
Motor Voltage 1-22	6-5
Motor Wiring Overview	4-20

N

Name Plate Data	4-36
Name Plate Data.	4-36
No Operation	6-3
No-flow Delay 22-24	6-49
No-flow Function 22-23	6-49
Non-ul Fuses 200 V To 480 V	4-8

O

Output Performance (u, V, W)	8-7
Overmodulation 14-03	6-40
Over-voltage Control 2-17	6-25

P

Parameter Data	6-1
Parameter Set-up	6-53
Parameters For Quick Set-up	6-4
Pc Software Tools	5-8
Pid Auto Tuning 20-79.....	6-47
Pid Integral Time 20-94.....	6-49
Pid Normal/ Inverse Control 20-81.....	6-48
Pid Output Change 20-72.....	6-47
Pid Proportional Gain 20-93.....	6-48
[Pid Start Speed Hz] 20-83.....	6-48
[Pid Start Speed Rpm] 20-82.....	6-48
Preset Reference 3-10.....	6-26
Protection And Features	8-10
Pulse Inputs	8-8

Q

Quick Menu	5-4, 6-55
Quick Menu Mode	5-4
Quick Menu Mode	6-1
Quick Set-up Parameters	6-4
Quick Transfer Of Parameter Settings When Using	5-10

R

Ramp 1 Ramp-down Time 3-42.....	6-6
Ramp 1 Ramp-up Time 3-41.....	6-6
Reference 1 Source 3-15.....	6-27
Reference 2 Source 3-16.....	6-27
Relay Connection	4-28
Relay Output	4-30
Relay Outputs	8-9
Rs-485 Bus Connection	5-7

S

Safety Note	1-2
Safety Regulations	1-2
Safety Requirements Of Mechanical Installation	3-6
Screened/armoured.	4-7
Semi-auto Bypass Set-up 4-64.....	6-28
Serial Communication	8-10
Set Date And Time 0-70.....	6-20
Setpoint 1 20-21.....	6-46
Setpoint 2 20-22.....	6-46
Setpoint Boost 22-45.....	6-50
Short Cycle Protection 22-75.....	6-51
Side-by-side Installation	3-5
Sine-wave Filter	4-19
Start Delay 1-71.....	6-22
Stator Leakage Reactance	6-22
Status	5-4
Status Messages	5-1
Step-by-step	6-57
Surroundings:	8-10
Switches S201, S202, And S801	4-35
Switching Frequency 14-01.....	6-40

T

Terminal 27 Digital Input 5-12.....	6-8, 6-31
Terminal 27 Mode 5-01.....	6-29
Terminal 29 Mode 5-02.....	6-29
Terminal 42 Output 6-50.....	6-37
Terminal 42 Output Max Scale 6-52.....	6-38

Terminal 42 Output Min Scale 6-51	6-38
Terminal 53 Filter Time Constant 6-16	6-35
Terminal 53 High Current 6-13	6-35
Terminal 53 High Ref./feedb. Value 6-15	6-35
Terminal 53 High Voltage 6-11	6-34
Terminal 53 Live Zero 6-17	6-35
Terminal 53 Low Current 6-12	6-35
Terminal 53 Low Ref./feedb. Value 6-14	6-35
Terminal 53 Low Voltage 6-10	6-34
Terminal 54 Filter Time Constant 6-26	6-36
Terminal 54 High Current 6-23	6-35, 6-36
Terminal 54 High Ref./feedb. Value 6-25	6-36
Terminal 54 High Voltage 6-21	6-36
Terminal 54 Live Zero 6-27	6-37
Terminal 54 Low Current 6-22	6-35, 6-36
Terminal 54 Low Ref./feedb. Value 6-24	6-36
Terminal 54 Low Voltage 6-20	6-36
Thermistor	6-24
Thermistor Source 1-93	6-25
Tightening Of Terminals	4-5
Time Format 0-72	6-20
Torque Characteristics 1-03	6-21, 8-7
[Trip Speed Low Hz] 1-87	6-23
[Trip Speed Low Rpm] 1-86	6-23
Tuning Mode 20-71	6-47
Two Ways Of Operating	5-1
Type Code String (t/c)	2-3
Type Code String Low And Medium Power	2-4

U

UI Compliance/non-compliance	4-8
UI Fuses, 200 - 240 V	4-9
Usb Connection.	4-32

V

Variable (quadratic) Torque Applications (vt)	8-13
Voltage Level	8-7

W

Wake-up Ref./fb Difference 22-44	6-50
[Wake-up Speed Hz] 22-43	6-50
[Wake-up Speed Rpm] 22-42	6-50
Warning Against Unintended Start	1-3
Warning Feedback High 4-57	6-28
Warning Feedback Low 4-56	6-28
Warning Speed High 4-53	6-28
Wiring Example And Testing	4-27



www.trane.com

For more information, contact your local Trane office or e-mail us at comfort@trane.com

Literature Order Number	BAS-SVX19C-EN
Date	March 2010
Supersedes	August 2009

Trane has a policy of continuous product and product data improvement and reserves the right to change design and specifications without notice.

