



# Installation, Operation, and Maintenance

# **Symbio™ 400–B/500 Programmable**

# **Controllers**

## Water Source Heat Pump (WSHP)



### **⚠ SAFETY WARNING**

Only qualified personnel should install and service the equipment. The installation, starting up, and servicing of heating, ventilating, and air-conditioning equipment can be hazardous and requires specific knowledge and training. Improperly installed, adjusted or altered equipment by an unqualified person could result in death or serious injury. When working on the equipment, observe all precautions in the literature and on the tags, stickers, and labels that are attached to the equipment.



## Overview

The Symbio 400–B/500 is a multi-purpose, programmable (or application-specific) controller that provides direct-digital zone temperature control. This controller can operate as a stand-alone device or as part of a building automation system (BAS). Communication between the controller and a BAS occurs on an open standard with inter-operable protocols used in Building Automation and Control Networks (BACnet®). Programming is done by means of the Tracer® TU service tool. This guide provides installation and configuration information for the Symbio 400–B/500 Controller with specific operation description for Water Source Heat Pump (WSHP).

**Note:** *LonTalk Communications are not supported on Symbio 210/210e/400–B/500.*

## Copyright

This document and the information in it are the property of Trane, and may not be used or reproduced in whole or in part without written permission. Trane reserves the right to revise this publication at any time, and to make changes to its content without obligation to notify any person of such revision or change.

## Trademarks

All trademarks referenced in this document are the trademarks of their respective owners.

## Agency Listings and Compliance

The European Union (EU) Declaration of Conformity is available from your local Trane® office.

## Revision History

- Updated the General Information section.
- Added a new section BACnet/IP Over Wi-Fi Communications.
- Updated the number of software points available in the Configuration and Maintenance section.



# Table of Contents

BACnet® Protocol .....	6
BACnet Testing Laboratory (BTL) Certification .....	6
Specifications and Dimensions .....	7
Device Connections .....	9
Additional Components .....	11
Water, Discharge, and Outdoor Air Temperature Sensors .....	11
Binary Input Switching Devices .....	11
Zone Temperature Sensors .....	11
Valve and Damper Actuators .....	12
Zone Humidity Sensor .....	12
Expansion Modules .....	12
Typical Applications and Terminations .....	13
Binary Inputs .....	15
BI1; Occupancy .....	15
BI2; Compressor 1 Protection Status .....	15
BI3; Compressor 2 Protection Status .....	15
BI3/BI4; Frost Detection .....	15
BI5; Fan Status .....	15
Analog Inputs .....	15
Ground Terminals .....	15
AI1; Space Temperature .....	16
AI2; Space Temperature Local Setpoint .....	16
AI3; Local Fan Mode Input .....	16
AI4; Discharge Air Temperature Sensor .....	16
AI5; Entering Water Temperature .....	16
Universal Inputs .....	17
UI1; Leaving Water Temperature .....	17
UI2; Relative Humidity or CO <sub>2</sub> Sensor .....	17
Pressure Inputs .....	17
PI1; Condensate Overflow .....	17
Wiring Requirements .....	17
Symbio 500 Wiring Diagrams .....	18
Symbio 400–B Wiring Diagrams .....	24
Wiring Installation .....	29
BACnet® MS/TP Communication Link .....	29
BACnet/IP Over Wired Ethernet Communications .....	29
BACnet/IP Over Wi-Fi Communications .....	29
Air-Fi Wireless BACnet® Communications .....	29
Wiring Guidelines for Wired BACnet MS/TP .....	29
Wiring Best Practices .....	30



- Setting Up the Controller on a BACnet Link ..... 30
  - Setting the Address..... 31
  - BACnet Networks Without a Tracer SC+ System Controller ..... 31
  - BACnet Networks With a Tracer SC+ System Controller ..... 32
- Ethernet ..... 32
- Power Supply ..... 33
  - Transformer Recommendations ..... 34
  - Wiring Recommendations ..... 34
  - Connecting Wires ..... 34
  - Power On Check ..... 35
- LEDs..... 36
  - LED Locations..... 36
  - LED Descriptions, Activities, and Troubleshooting ..... 37
  - Marquee LED Status and Error Codes ..... 38
- Sequence of Operations ..... 41
  - Power-up Sequence ..... 41
  - Random Start ..... 41
  - Occupancy Modes ..... 41
    - Occupied Mode ..... 42
    - Unoccupied Mode ..... 42
    - Occupied Standby Mode ..... 42
    - Occupied Bypass Mode ..... 42
    - Timed Override Control ..... 43
    - Heat/Cool Operation..... 43
    - Fan Operation ..... 43
    - Single-Zone VAV/Variable Speed Fan Operation..... 44
    - Entering Water Temperature Sampling Function ..... 46
    - Electric Heat Operation ..... 48
    - Other Modes ..... 49
- Operational Troubleshooting ..... 52
  - Diagnostics ..... 52
  - Override Outputs ..... 53
  - Resetting Diagnostics ..... 55
    - High/Low Pressure Cutout..... 55
    - Manual Output Test..... 55
    - Cycling Power ..... 55
    - Building Automation System (BAS) ..... 55
    - Tracer TU Service Tool..... 55
    - Cycling the Fan Switch..... 55
- Operational Causes and Diagnostics..... 56
- Configuration and Maintenance..... 59

Additional Resources ..... 61



## BACnet® Protocol

The Building Automation and Control Network (BACnet®) protocol is ANSI/ASHRAE Standard 135. This standard allows building automation systems or components from different manufacturers to share information and control functions. BACnet® provides building owners the capability to connect various types of building control systems or subsystems together for many uses. Multiple vendors can use this protocol to share information for monitoring and supervisory control between systems and devices in a multi-vendor interconnected system. The BACnet® protocol defines standard objects (data points) called BACnet® objects. Each object has a defined list of properties that provide context information about that object. In addition, BACnet® defines a number of application services that are used to interact with objects in a BACnet® device.

## BACnet Testing Laboratory (BTL) Certification

The Symbio 400–B/500 is BTL certified as a B-BC profile device. A complete list of Trane certified devices is available at [www.bacnetinternational.org](http://www.bacnetinternational.org).



# Specifications and Dimensions

**Table 1. Symbio 400–B/500 specifications**

Storage	
Temperature	-67°F to 203°F (-55°C to 95°C)
Relative humidity	Between 5% to 95% (non condensing)
Operating	
Temperature	-40°F to 158°F (-40°C to 70°C)
Humidity	Between 5% to 95% (nonconducting)
Power	20.4–27.6 Vac (24 Vac, ±15% nominal) 50–60 Hz 24 VA
Mounting weight of controller	Mounting surface must support 0.80 lb. (0.364 kg)
Environmental rating (enclosure)	NEMA 1
Plenum rating	Not plenum rated. The Symbio 500 must be mounted within a rated enclosure when installed in a plenum.
Wiring/Transformer	
16 AWG (recommended) copper wire	
<ul style="list-style-type: none"> <li>• UL Listed, Class 2 power transformer 20.4–27.6 Vac (24 Vac, ±15% nominal)</li> <li>• The transformer must be sized to provide adequate power to the controller and outputs. For more information on transformer sizing, see BAS-SVX090*-EN.</li> </ul>	
Agency Compliance	
<ul style="list-style-type: none"> <li>• UL60730-1 PAZX (Open Energy Management Equipment)</li> <li>• UL94-5V Flammability</li> <li>• CE Marked. The European Union (EU) Declaration of Conformity is available from your local Trane® office.</li> <li>• UKCA Marked</li> <li>• FCC Part 15, Subpart B, Class B Limit</li> <li>• VCCI-CISPR 32:2016: Class B Limit</li> <li>• AS/NZS CISPR 32:2015: Class B Limit</li> <li>• CAN ICES-003(B)/NMB-003(B)</li> <li>• The Symbio 400–B is BTL certified as a B-BC profile device. A complete list of Trane certified devices is available at <a href="http://www.bacnetinternational.org">www.bacnetinternational.org</a>.</li> </ul> <p><b>Note:</b> The Symbio 500 programmable controller supports being a BBMB. This is a specific functionality and is different than the profile certification. The Symbio 500 cannot be a router.</p>	

Figure 1. Symbio 400-B/500 dimensions

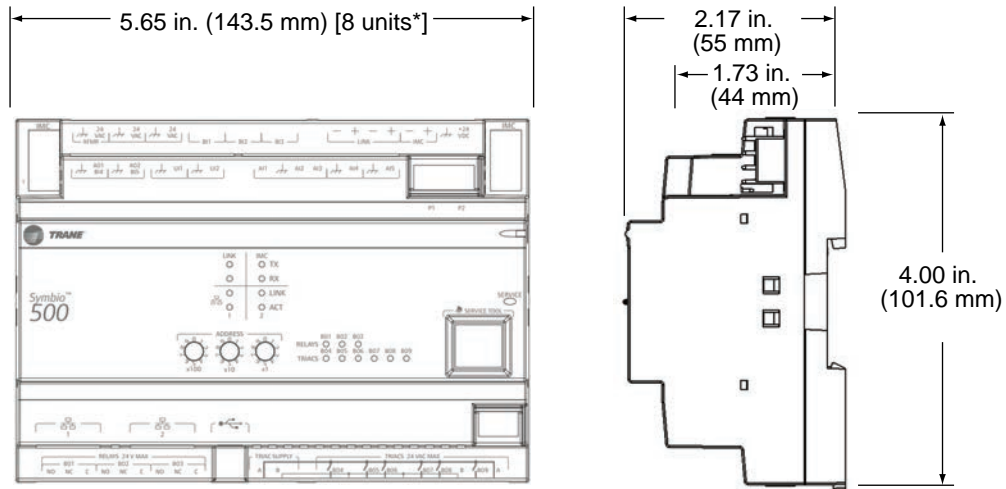

\*DIN Standard 43 880, Built-in Equipment for Electrical Installation. Overall Dimensions and Related Mounting Dimensions. □

For mounting and clearance recommendations, refer to *Symbio 500 Programmable Controller Installation, Operation, and Maintenance Manual (BAS-SVX090\*-EN)*.

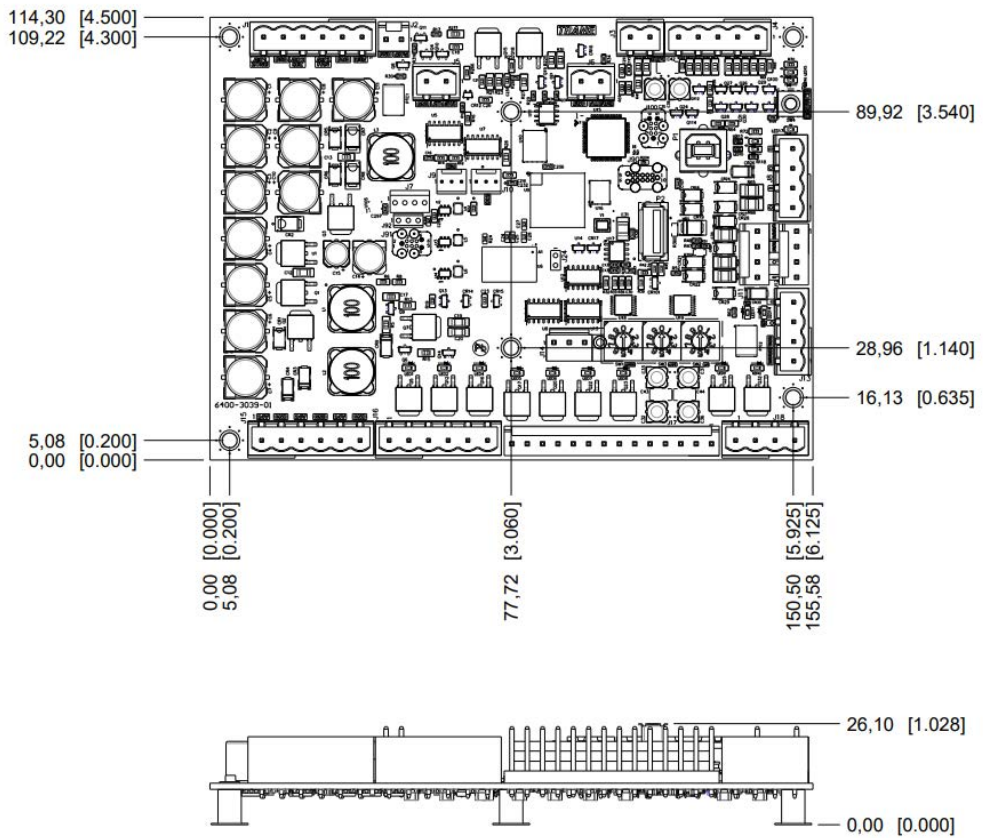





# Device Connections

The following table provides details of the hardware termination configuration options. The hardware terminations are pre-configured for proper equipment operation for blower coil/fan coil applications.

**⚠ WARNING**

**Live Electrical Components!**  
**Failure to follow all electrical safety precautions when exposed to live electrical components could result in death or serious injury.**  
**When it is necessary to work with live electrical components, have a qualified licensed electrician or other individual who has been properly trained in handling live electrical components perform these tasks.**

**Table 2. Device connections**

Connection	Quantity	Types	Range	Notes
Analog Input (AI1 to AI5)	5	Thermistor	10kΩ – Type II, 10kΩ – Type III, 2252Ω – Type II, 20kΩ – Type IV, 100 kΩ	These inputs can be configured for timed override capability. Supports *, ** for Trane Zone Sensors.
		RTD	Balco™ (Ni-Fe) 1kΩ, 385 (Pt) 1kΩ, 375 (Pt) 1kΩ, 672 (Ni) 1kΩ,	
		Setpoint (Thumbwheel)	189Ω to 889Ω	
		Resistive	100Ω to 100kΩ	Typically used for fan speed switch.
Universal input (UI1 and UI2)	2	Linear Current	0–20mA	These inputs may be configured to be thermistor or resistive inputs, 0– 10 Vdc inputs, or 0–20 mA inputs.
		Linear Voltage	0–10Vdc	
		Thermistor	10kΩ – Type II, 10kΩ – Type III, 2252Ω – Type II, 20kΩ – Type IV, 100 kΩ	
		RTD	Balco™ (Ni-Fe) 1kΩ, 385 (Pt) 1kΩ, 375 (Pt) 1kΩ, 672 (Ni) 1kΩ,	
		Setpoint (Thumbwheel)	189 Ω to 889 Ω	
		Resistive	100Ω to 100kΩ	
		Binary	Dry contact	Low impedance relay contact.
		Pulse Accumulator	Solid state open collector	Minimum dwell time is 25 milliseconds ON and 25 milliseconds OFF.
Binary input (BI1 to BI3)	3		24 Vac detect	The controller provides the 24Vac that is required to drive the binary inputs when using the recommended connections.
Binary Outputs (BO1 to BO3)	3	Form C Relay	0.5A @ 24Vac pilot duty	Ranges given are per contact. Power needs to be wired to the binary output. All outputs are isolated from each other and from ground or power.
		Other Ranges	Symbio 400–B: TRIAC	24Vac Powered <b>Note:</b> Class 1 voltages shall not be used on Symbio 400–B or Symbio 500 controllers.
Binary Outputs (BO4 to BO9)	6	Triac	0.5A @ 24Vac resistive and pilot duty	Ranges given are per contact and power comes from the TRIAC SUPPLY circuit. Use for modulating TRIACs. User determines whether closing high side (providing voltage to the grounded load) or low side (providing ground to the power load).



## Device Connections

**Table 2. Device connections (continued)**

Connection	Quantity	Types	Range	Notes
Analog Output / Binary Input (AO1/ BI4 and AO2/ BI5)	2	Linear Current	0 - 20mA	Each termination must be configured as either an analog output or binary input.
		Linear Voltage	0 - 10Vdc	
		Binary Input	Dry contact	
		Pulse Width Modulation	80 Hz signal @ 15Vdc	
Pressure Inputs (PI1 and PI2)	2		0 - 5 In H2O	Pressure inputs supplied with 5 volts (designed for Kavlico™ pressure transducers).
<b>Point total</b>	<b>23</b>			



# Additional Components

The Symbio 400–B/500 controller requires the use of additional components for monitoring and proper control of associated equipment. The use of specific components is dependent on the type of application.

**Note:** Additional components are not included with the Symbio 400–B/500 Controller.

## Water, Discharge, and Outdoor Air Temperature Sensors

Temperature sensors must be Trane 10 kΩ (at 25°C) thermistors. Entering water and discharge air inputs can use a sealed temperature sensor (part numbers 4190 1100 and 4190 1133).

## Binary Input Switching Devices

Occupancy, condensate overflow, compressor protection, frost detection, and fan status inputs accept switching devices that may have normally open (NO) or normally closed (NC) dry contacts.

## Zone Temperature Sensors

The following table provides the sensor types and features supported by the Symbio 400–B/500 Controller.

**Table 3. Symbio 400–B/500 controller supported sensors and features**

Sensor Type	Features					Part Number	BAYSENS	Global Parts
	Setpoint	Fan Control	System	Occupancy	LEDs			
Temperature Sensor	No	No	No	No	No	X1351152801	BAYSENS077A	SEN01448
	No			Yes		X1351153001	BAYSENS073A	SEN01450
Temperature Sensors w/ Fan Control	Single	<ul style="list-style-type: none"> <li>• Off</li> <li>• Auto</li> </ul>	No	Yes	No	X1379084501	N/A	SEN01521
	Single	<ul style="list-style-type: none"> <li>• Off</li> <li>• Auto</li> <li>• Low</li> <li>• High</li> </ul>		Yes		X1379084801		SEN01524
	Single	<ul style="list-style-type: none"> <li>• Off</li> <li>• Auto</li> <li>• Low</li> <li>• Medium</li> <li>• High</li> </ul>		Yes		X1379084201		SEN01518
Temperature Sensor w/LCD Display <sup>(a)</sup>	Single	<ul style="list-style-type: none"> <li>• Off</li> <li>• Auto</li> <li>• Low</li> <li>• Medium</li> <li>• High</li> </ul>	No	Can be configured for occupancy	No	X1379088604	N/A	N/A



## Additional Components

**Table 3. Symbio 400–B/500 controller supported sensors and features (continued)**

Sensor Type	Setpoint	Features				Part Number	BAYSENS	Global Parts
		Fan Control	System	Occupancy	LEDs			
WCS-SD	Single	<ul style="list-style-type: none"> <li>• Auto</li> <li>• On</li> </ul>	Yes	Yes	No	X13790955050	BAYSENS202A	SEN02263

<sup>(a)</sup> This sensor can be field configured to match the applicable unit controller options. Unit controller inputs for system status, fan, and service required are not available on this sensor. If replacing a BAYSENS031A or a BAYSENS035A sensor, and status indicators are required, replace with non-display sensor BAYSENS109A or BAYSENS110A.

## Valve and Damper Actuators

The 2-position analog and 3-wire floating point modulating actuators cannot exceed 12 VA draw at 24 Vac. For 2-position valves, use actuators with ON/OFF and spring actions that returns the valve to normally open (NO) or closed (NC), which are dependent on the desired default position. For modulating actuators, use actuators with or without a spring return, as required by the application.

## Zone Humidity Sensor

For measurement of relative humidity (RH), the Symbio 400–B/500 controller requires a zone humidity sensor with a 4–20 mA output, where 4 mA is 0% RH and 20 mA is 100% RH. The controller provides 24 Vdc to power the zone humidity sensor.

**Note:** As an option, the Symbio 400–B/500 controller can receive humidity from a Trane Air-*f*i™ WCS Wireless Sensor with Humidity (WCS-SH Relative Humidity module part number X13790973030).

## Expansion Modules

The Symbio 400–B/500 controller has 32 on-board points. The controller can be point-expanded by using expansion modules.

- The Symbio 400–B can have an additional 32 remote points, for a total of 55 points.
- The Symbio 500 can have an additional 110 points, for a total of 133 points.

Any combination of XM30, XM32, XM70, or XM90 Expansion Modules are supported. A maximum of two XM30, or XM32 modules (in aggregate) can be powered from the DC power of the IMC link. XM70 and XM90 modules require an AC power supply.

For more information, refer to the Tracer XM30, XM32, XM70, and XM90 Expansion Modules Installation, Operations, and Maintenance manual BAS-SVX46\*-EN.



# Typical Applications and Terminations

The following tables provide information about supported applications and termination wiring.

**Table 4. Symbio 400–B/500 controller typical applications**

	Waterside Economizing	Hot Gas Reheat	Electric Heat	Boiler-less
Heat Pump	X			
		X		
			X	
				X
	X	X		
	X	X	X	
	X	X		X
	X		X	
	X			X
	Cooling Only	X		
		X		
X		X	X	
X		X	X	
X			X	

The following table lists 1 or 2 compressor control with discrete 1– or 2–speed fans based on Trane GE units.

**Table 5. Factory programmed terminations for Trane GE units**

Inputs/Outputs/Communication	Symbio 400–B/500 Controller Terminations	Factory Programmed Assumed Terminations
Analog Inputs	AI1	Space Temperature Local
	AI2	Space Temperature Setpoint Local
	AI3	Local Fan Mode Switch
	AI4	Discharge Air Temperature Sensor
	AI5	Entering Water Temperature Sensor
Universal Inputs	UI1	Relative Humidity Sensor or CO <sub>2</sub> Sensor
	UI2	Leaving Water Temperature
Binary Inputs	BI1	Occupancy
	BI2	Compressor 1 lockout status
	BI3	Compressor 2 lockout status
Binary Outputs (Relay)	BO1	Fan High
	BO2	Waterside Economizer
	BO3	Fan Low



## Typical Applications and Terminations

**Table 5. Factory programmed terminations for Trane GE units (continued)**

Inputs/Outputs/Communication	Symbio 400–B/ 500 Controller Terminations	Factory Programmed Assumed Terminations
Binary Outputs (TRIAC)	BO4	Compressor 1 Command
	BO5	Compressor 2 Command
	BO6	Hot Gas Reheat/Electric Heat <sup>(a)</sup>
	BO7	Reversing Valve
	BO8	Isolation Valve/External Pump
	BO9	Outdoor Air Damper
Analog Outputs/Binary Inputs	AO1/BI4	BI- Frost Detect (Coil Ice Protection)
	AO2/BI5	BI- Fan Status
Pressure Inputs	PI1	Condensate Overflow
	PI2	Unused
Service Button		Test Mode Input

<sup>(a)</sup> When Hot Gas Reheat and Electric Heat are present on the same WSHP, Electric Heat will be moved to BO1 on XM32.

The following table lists single compressor control with variable speed fan based on Trane EX/DX units.

**Table 6. Factory programmed terminations for single compressor control for Trane EX/DX units**

Inputs/Outputs/Communication	Symbio 400–B/ 500 Controller Terminations	Factory Programmed Assumed Terminations
Analog Inputs	AI1	Space Temperature Local
	AI2	Space Temperature Setpoint Local
	AI3	Local Fan Mode Switch
	AI4	Discharge Air Temperature Sensor
	AI5	Entering Water Temperature Sensor
Universal Inputs	UI1	Relative Humidity Sensor or CO <sub>2</sub> Sensor
	UI2	Leaving Water Temperature
Binary Inputs	BI1	Occupancy Input
	BI2	Compressor Protection Status (Monitors High/Low Pressure Cutout and Freeze Protection)
	BI3	Frost Detection
Binary Outputs (Relay)	BO1	Fan Enable
	BO2	Water Economizer
	BO3	No Connection
Binary Outputs (TRIAC)	BO4	Compressor Enable
	BO5	EX Series — No Connection DX Series — Compressor Step
	BO6	Hot Gas Reheat/Electric Heat <sup>(a)</sup>
	BO7	Reversing Valve
	BO8	Isolation Valve/External Pump
	BO9	Outdoor Air Damper

**Table 6. Factory programmed terminations for single compressor control for Trane EX/DX units (continued)**

Inputs/Outputs/Communication	Symbio 400–B/500 Controller Terminations	Factory Programmed Assumed Terminations
Analog Outputs/Binary Inputs	AO1/BI4	AO- Variable Speed Fan Control
	AO2/BI5	BI- Fan Status
Pressure Inputs	PI1	Condensate Overflow
	PI2	No Connection
Service Button		Test Mode Input

<sup>(a)</sup> When Hot Gas Reheat and Electric Heat are present on the same WSHP, Electric Heat will be moved to BO1 on XM32.

## Binary Inputs

The Symbio 400–B/500 controller has three (3) binary inputs and two (2) analog outputs/binary inputs (labeled BI1 through BI5), that can be configured as either analog outputs or binary inputs. Each binary input associates an input signal of 0 Vac with open contacts and 24 Vac with closed contacts. If changes are required, use the Tracer TU service tool to configure each of the inputs as normally open (NO) or normally closed (NC).

### BI1; Occupancy

Occupancy BI1 saves energy by spreading space temperature setpoints when the zone is unoccupied. Used as an occupancy input, BI1 has two (2) related functions:

- It changes the mode from occupied to occupied standby for controllers receiving a BAS-communicated occupancy request.
- It can be hard wired to a binary switch or time clock to determine the occupancy mode as either occupied or unoccupied for stand-alone controllers.

### BI2; Compressor 1 Protection Status

Factory programming monitors high and low pressure cutouts and compressor freeze protection of Compressor 1 on this input.

### BI3; Compressor 2 Protection Status

Factory programming monitors high and low pressure cutouts and compressor freeze protection of Compressor 2 on this input.

### BI3/BI4; Frost Detection

The frost detection sensor detects conditions that produce frost on the coil surface. When these conditions are present, the Symbio 400–B/500 controller detects the condition and generates a Frost Detection Input alarm.

### BI5; Fan Status

Fan Status BI5 provides feedback to the Symbio 400–B/500 controller regarding the operating status of the fan. If BI5 is wired to a fan status switch, and the input indicates that the fan is not operating when the controller has the fan controlled to ON, the controller generates a Low Primary Airflow Diagnostic.

## Analog Inputs

The Symbio 400–B/500 controller has five (5) analog inputs.

### Ground Terminals

Use the  terminal as the common ground for all space temperature sensor analog inputs.



## Typical Applications and Terminations

---

### AI1; Space Temperature

Space Temperature AI1 functions as the local (hard wired or wireless) space temperature input. The Symbio 400–B/500 controller receives the space temperature as a resistance signal from a 10 k $\Omega$  thermistor in a standard Trane space temperature sensor that is wired to analog input AI1. A space temperature value communicated by means of a BACnet link, can be used for controllers operating on a BAS. When both a hard wired and communicated space temperature value are present, and in service, the controller uses the communicated value.

If neither a hard wired nor a communicated space temperature value is present, the space temperature local and active points go into a fault state and generates an alarm. If neither the hard wired or communicated space temperature are valid, the equipment will shut down.

### AI2; Space Temperature Local Setpoint

Space Temperature Local Setpoint AI2 functions as the local (hard wired) space temperature setpoint input for applications utilizing a Trane space temperature sensor with a temperature setpoint thumbwheel or digital setpoint input. A setpoint value communicated by means of a BACnet link, can be used for controllers operating on a BAS. If both hard wired and communicated setpoint values are present, and in service, the Symbio 400–B/500 controller uses the communicated value.

In addition, the controller can be configured to use the local (hard wired) input value instead of the communicated value using the Tracer TU service tool. If neither a hard wired nor a communicated setpoint value is present, the controller uses the space temperature setpoint default analog value, which is configured using the Tracer TU service tool. If a local setpoint value is not valid or not present, the controller generates a Space Temperature Setpoint Local alarm.

### AI3; Local Fan Mode Input

Local Fan Mode Input AI3 functions as the local (hard wired) fan mode switch input for applications using the Trane space temperature sensor with a fan mode switch option. The various fan mode switch positions (OFF, LOW, MEDIUM, HIGH, AUTO) provide different resistances that are interpreted by the Symbio 400–B/500 controller.

**Note:** *The local fan speed switch can be disabled by taking out of service the multi-state point, supply fan speed local and setting the value for each to AUTO.*

A communicated fan mode request by means of the BACnet communications link, can be used for controllers operating on a BAS. If both hard wired and communicated fan mode values are present and in service, the Symbio 400–B/500 controller uses the communicated value. However, the controller can be configured to use the local (hard wired) input value instead of the communicated BAS value. The supply fan speed source (local or BAS) can be selected on the Tracer TU Setup Parameters page. If neither a hard wired nor a communicated fan mode value is present, the controller recognizes the fan mode value as AUTO and operates according to the default configuration. If a valid hard wired or communicated fan mode value is established, and then is no longer present, the controller generates a Supply Fan Speed Local alarm.

### AI4; Discharge Air Temperature Sensor

Discharge Air Temperature Sensor AI4 functions as the local discharge air temperature input.

The Symbio 400–B/500 controller receives the temperature as a resistance signal from a 10 k $\Omega$  thermistor wired to analog input AI4. The thermistor is typically located downstream from all unit heating and cooling coils at the unit discharge area. If a discharge air temperature value is invalid, or is not present, the controller generates a Discharge Air Temp Failure alarm.

### AI5; Entering Water Temperature

Entering Water Temperature AI5 functions as the local (hard wired) entering water temperature input. An entering water temperature communicated by means of the BACnet communications link (AV/4 Source Water Temperature BAS), can be used for Symbio 400–B/500 controller controllers operating on a BAS. If both hard wired and communicated entering water temperature values are present, and in service, the controller uses the communicated value. If a hard wired nor a communicated entering water temperature value is not valid, the controller generates an Entering Water Temperature Failure alarm.



## Universal Inputs

The Symbio 400–B/500 controller has two (2) universal inputs.

### UI1; Leaving Water Temperature

The UI1 analog input functions as the local (hard wired) leaving water temperature input. The unit can be configured to Alarm upon low leaving water temperatures.

### UI2; Relative Humidity or CO<sub>2</sub> Sensor

**Relative Humidity:** the pre-configured unit requires a 4-20 mA analog input corresponding linearly to a 0%-100% relative humidity.

**CO<sub>2</sub> Sensor Input:** the pre-configured unit requires a 4-20 mA analog input corresponding linearly to 0-2000 ppm. Factory applications do not support CO<sub>2</sub> control. Instead, they only monitor the status of the sensor input.

## Pressure Inputs

The Symbio 400–B/500–B/500 controller controller has two (2) pressure inputs.

*Note: PI2 has no connection.*

### PI1; Condensate Overflow

Condensate overflow prevents the condensate drain pan from overflowing and causing water damage to the building. If PI1 is wired to a condensate overflow switch, and the level of condensate reaches the trip point, the Symbio 400–B/500 controller detects the condition and generate a Condensate Overflow diagnostic.

## Wiring Requirements

The following table lists the required Symbio 400–B/500 controller inputs for proper minimum operation of all applications. The following wiring diagrams are separated to show first the Symbio 500 and then the Symbio 400–B.

**Table 7. Required inputs**

Function	Input source	Related information
24 Vac Power	Terminals: Ground, 24 Vac	For more details on power wiring requirements, refer to the Symbio 400–B/500 Programmable Controller Installation, Operation, and Maintenance Manual, BAS-SVX90*–EN.
Space Temperature Local.	Terminals: AI1, Ground	AI1; Space Temperature
Entering Water Temperature (Required Only for Units With Auto-changeover.	Terminal: AI5 or communicated	AI5; Entering Water Temperature



# Typical Applications and Terminations

## Symbio 500 Wiring Diagrams

Figure 2. Common input/sensor connections (Trane EX units only)

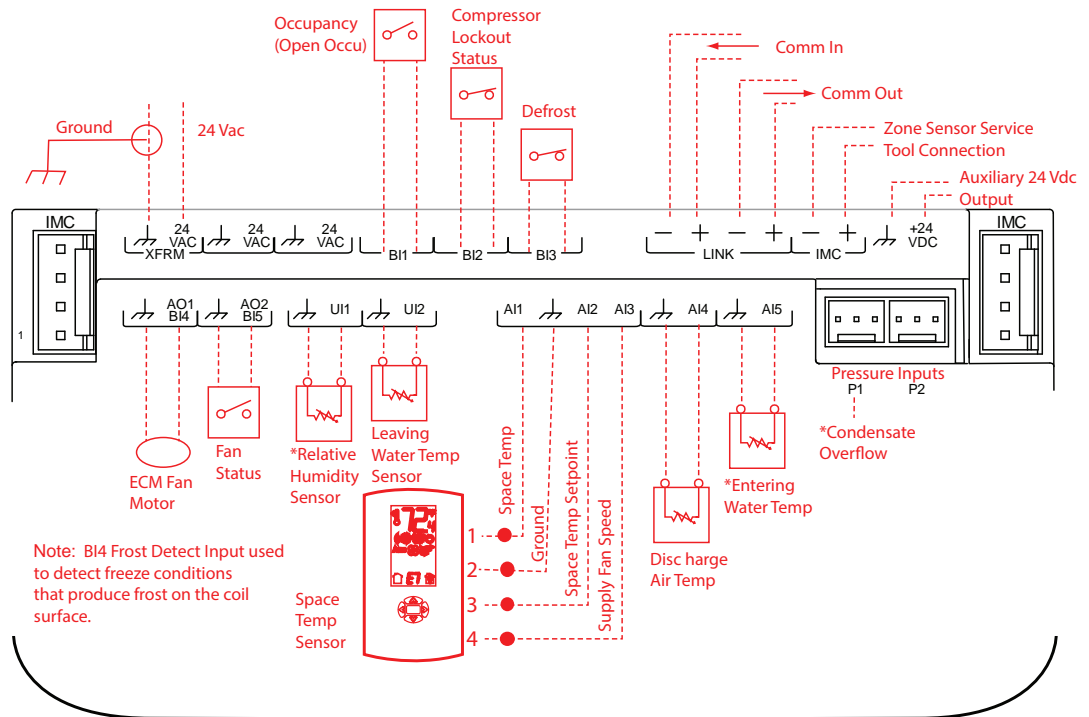

Two-Tier Terminal Connections

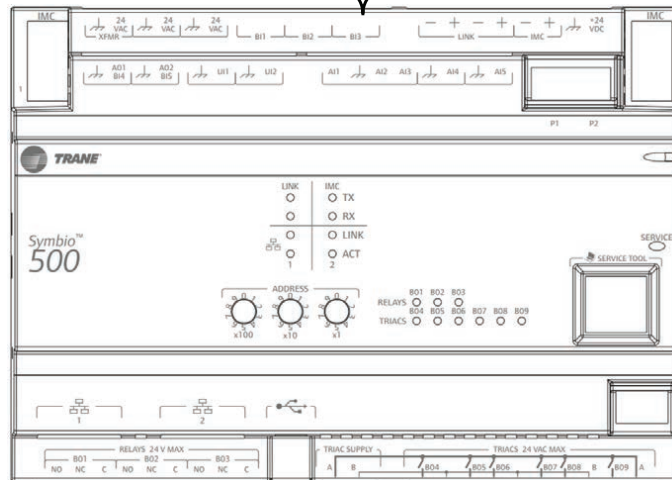

Asterisks (\*) Shown Above

- UI1 Relative Humidity Sensor can be used with dehumidifying unit instead of a BAS-communicated valve.
- AI5 Entering Water Temp Sensor used for auto-changeover units.
- P1 Condensate Overflow prevents the condensate drain from overflowing and causing water damage to the building.

**Figure 3. 2-position ventilation economizer (Trane EX units only)**

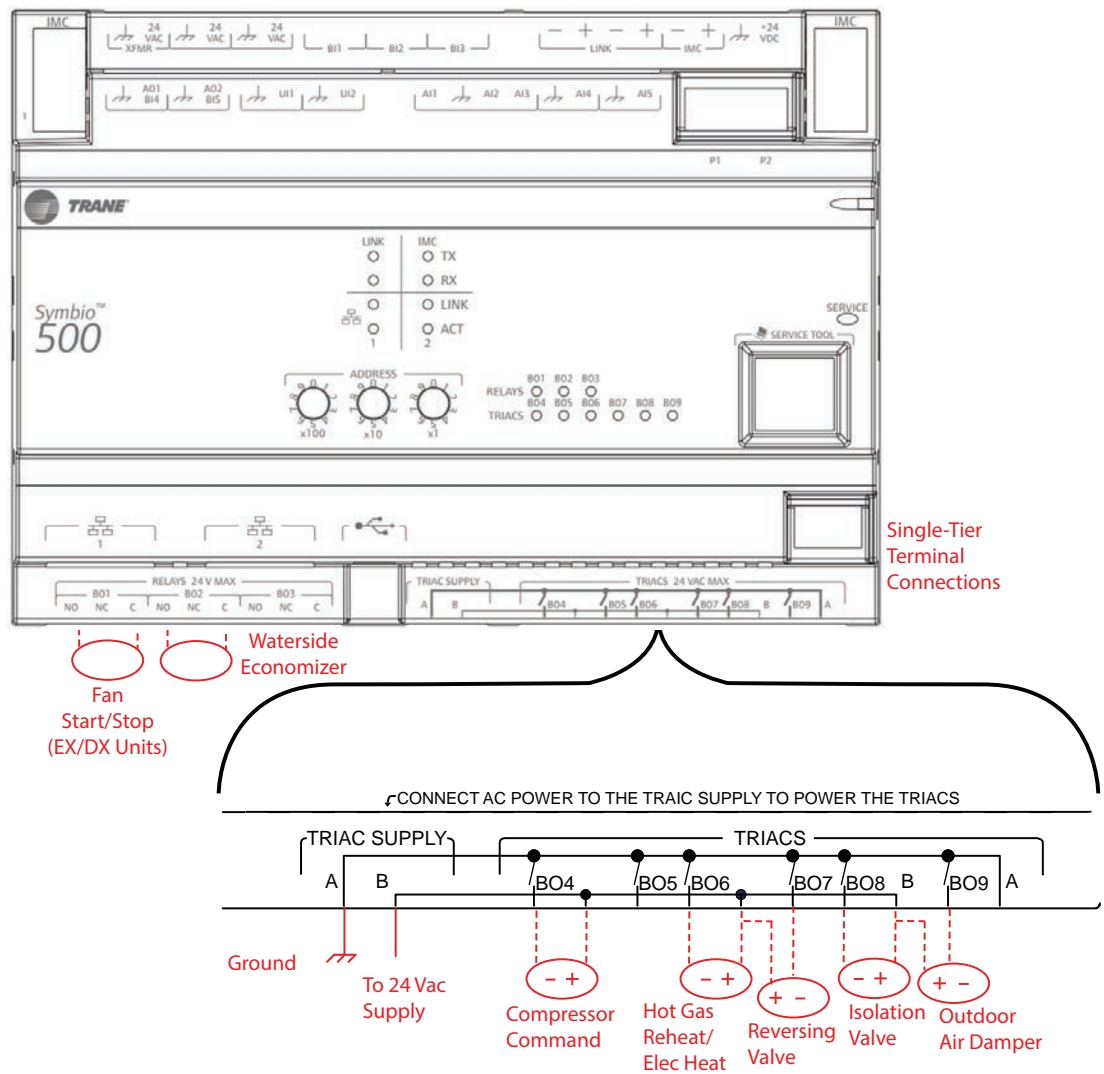

**NOTES:**

- BO5 is used for compressor stage 2 on DX units and BO4 is for compressor stage 1 on DX units.
- When Hot Gas Reheat and Electric Heat are present on the same WSH, Electric Heat will be moved to BO1 on XM32.

Figure 4. Common input/sensor connections (GE units only)

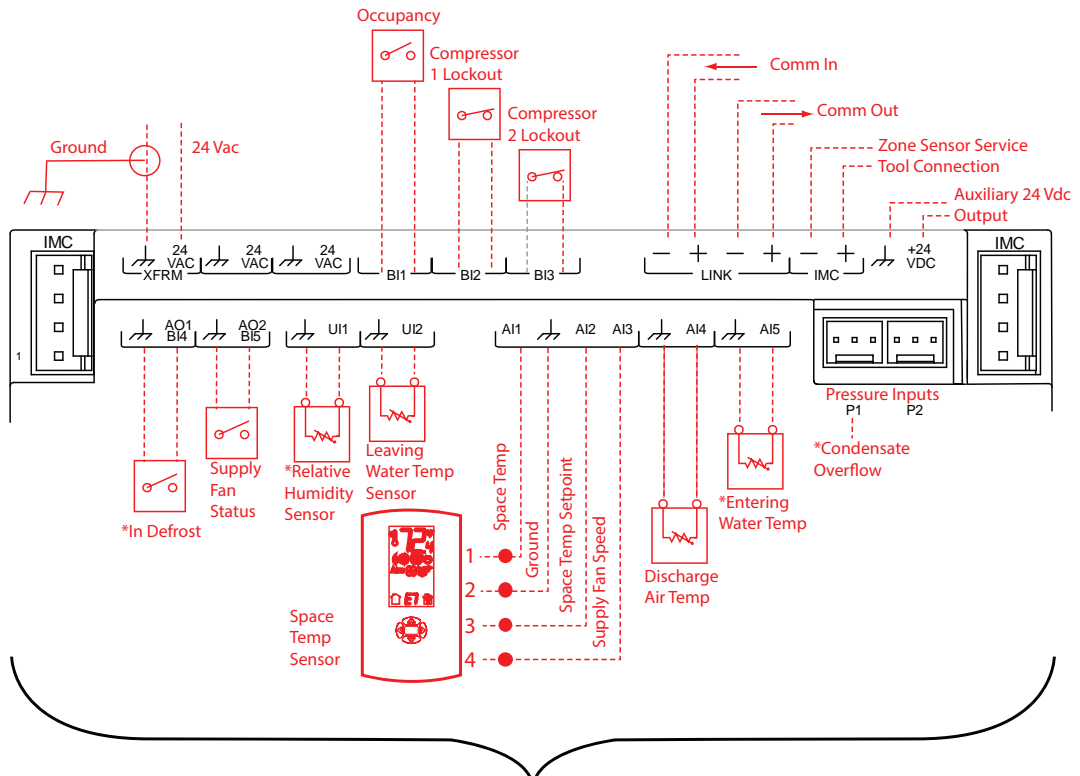

Two-Tier Terminal Connections

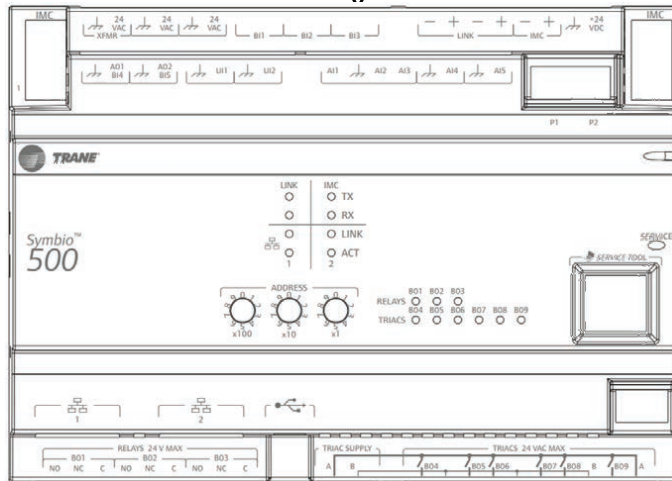

Asterisks (\*) Shown Above

- B14 Frost Detect Input used to detect freeze conditions that produce frost on the coil surface.
- UI1 Relative Humidity Sensor can be used with dehumidifying unit instead of a BAS-communicated valve.
- AI5 Entering Water Temp Sensor used for auto-changeover units.
- P1 Condensate Overflow prevents the condensate drain from overflowing and causing water damage to the building.

Figure 5. 2-position ventilation economizer (GE units only)

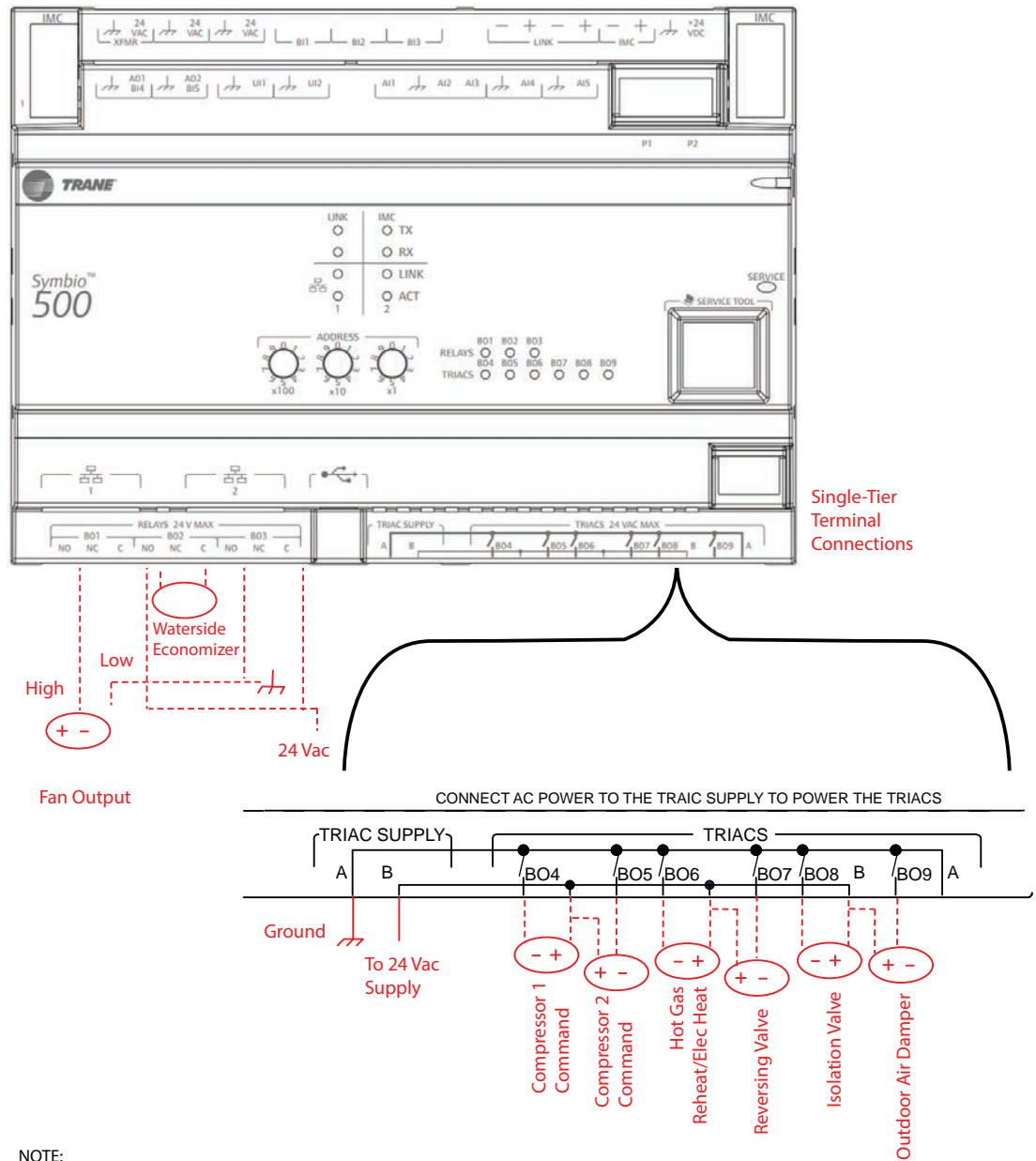

Single-Tier Terminal Connections

**Figure 6. Variable speed supply fan**

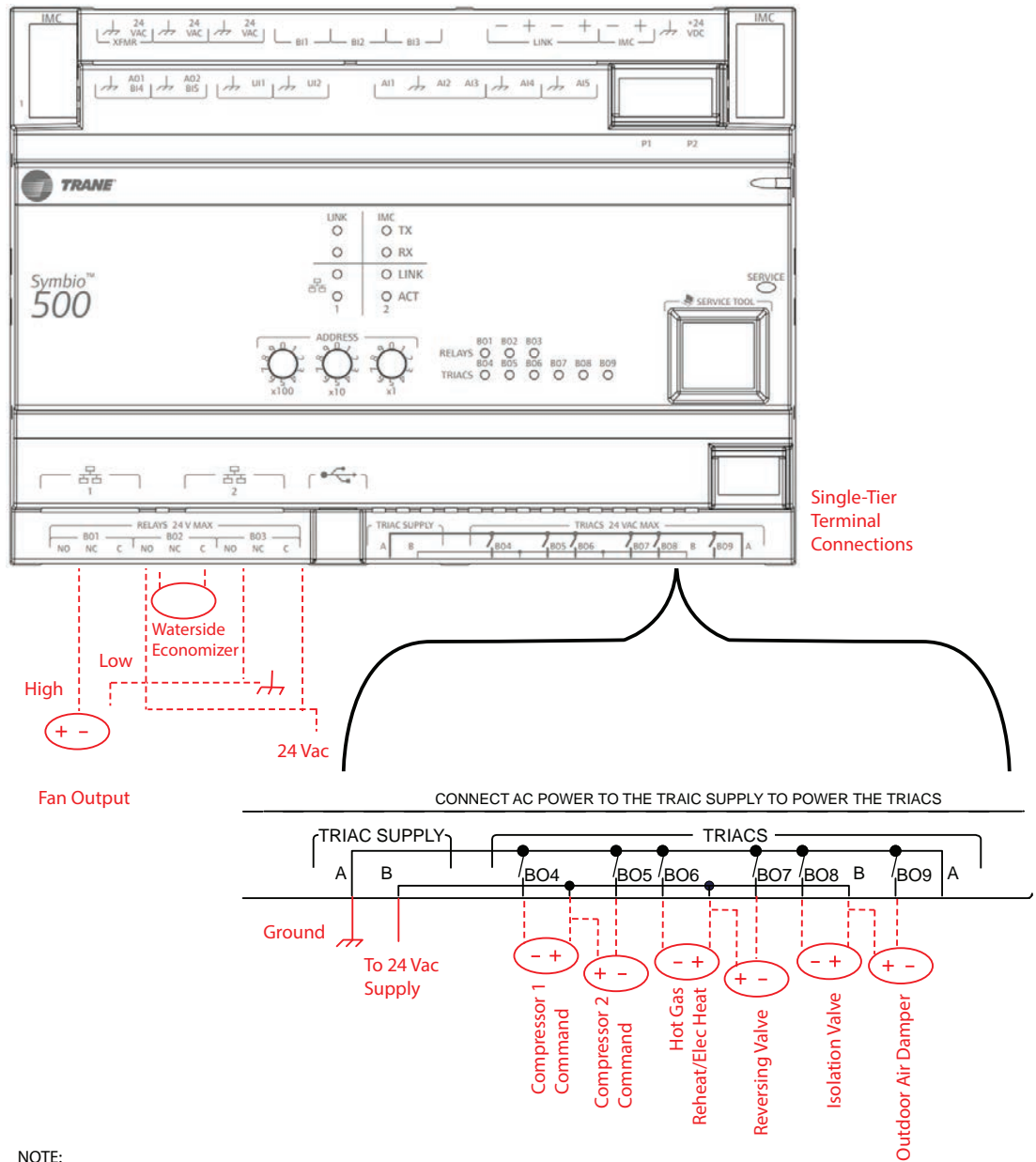

**NOTE:**  
When Hot Gas Reheat and Electric Heat are present on the same WSHP, Electric Heat will be moved to BO1 on XM32.

Figure 7. Relative humidity

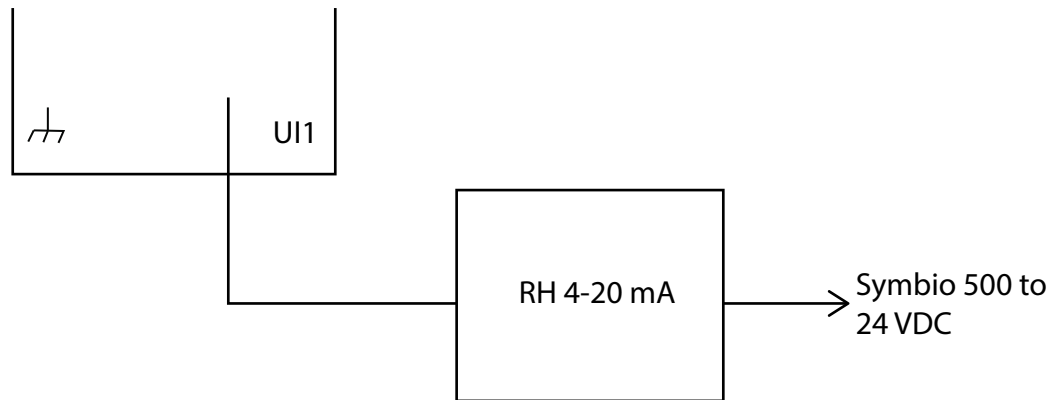
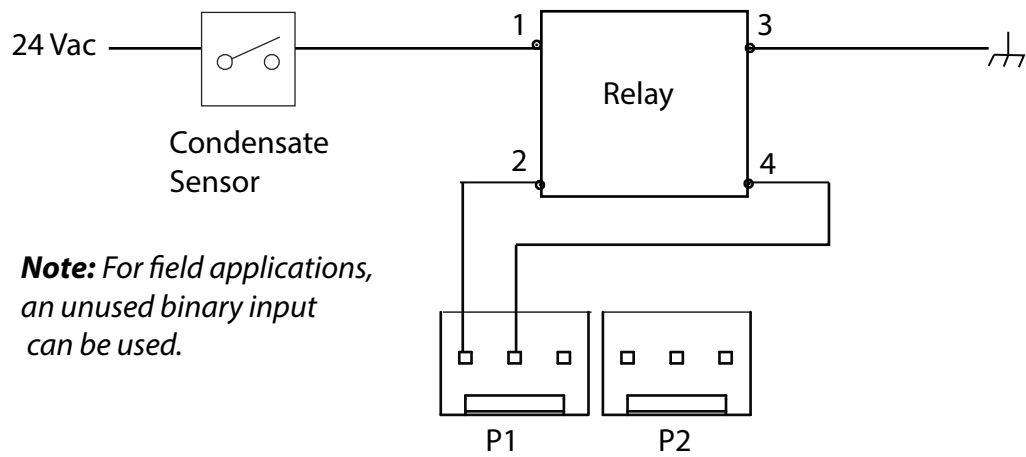

Figure 8. P1 condensate



**Note:** For field applications, an unused binary input can be used.

### Symbio 400-B Wiring Diagrams

Figure 9. Common input/sensor connections for GE units only

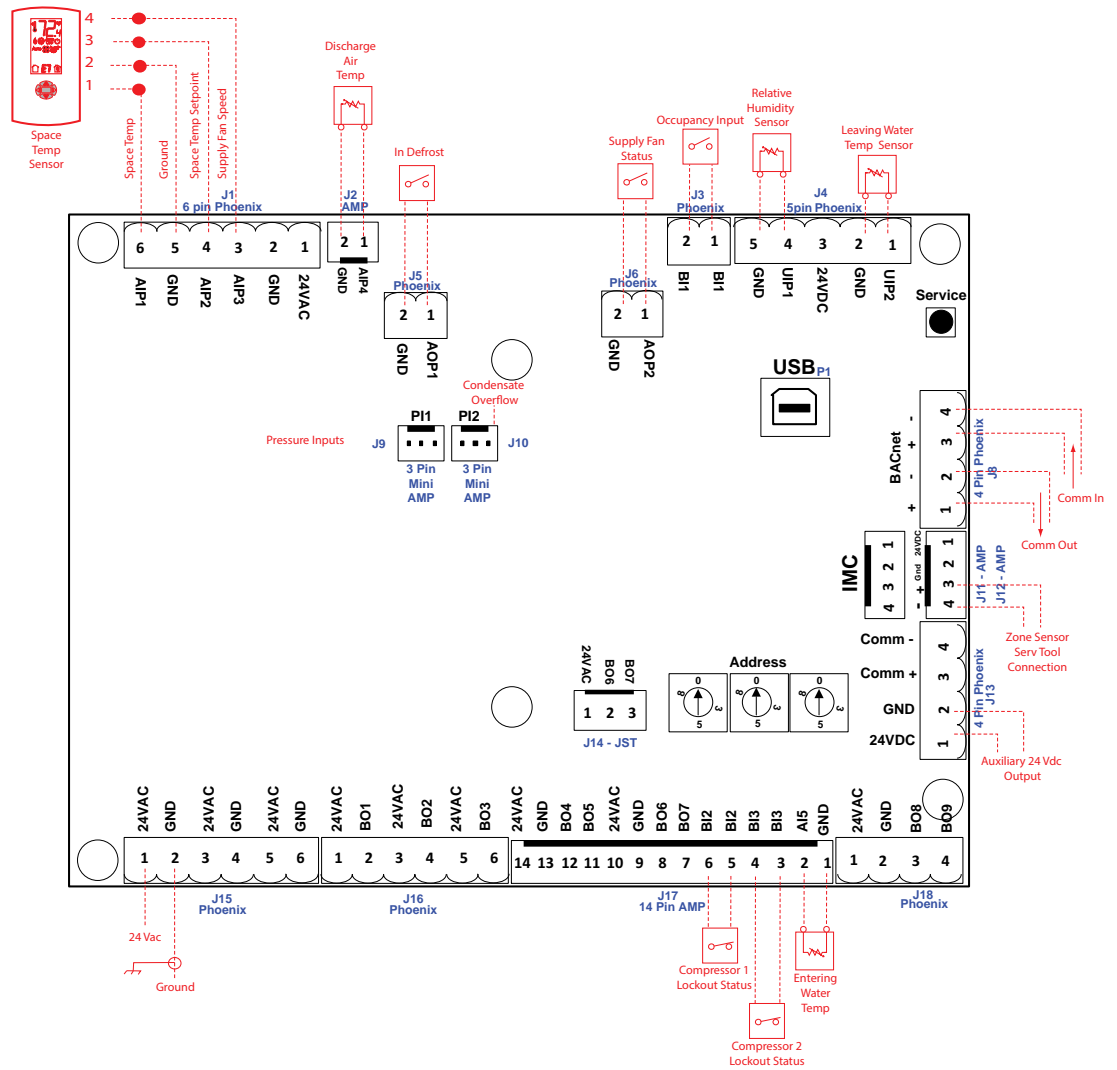



**Figure 10. 2-position ventilation economizer for Trane EX and DX units**

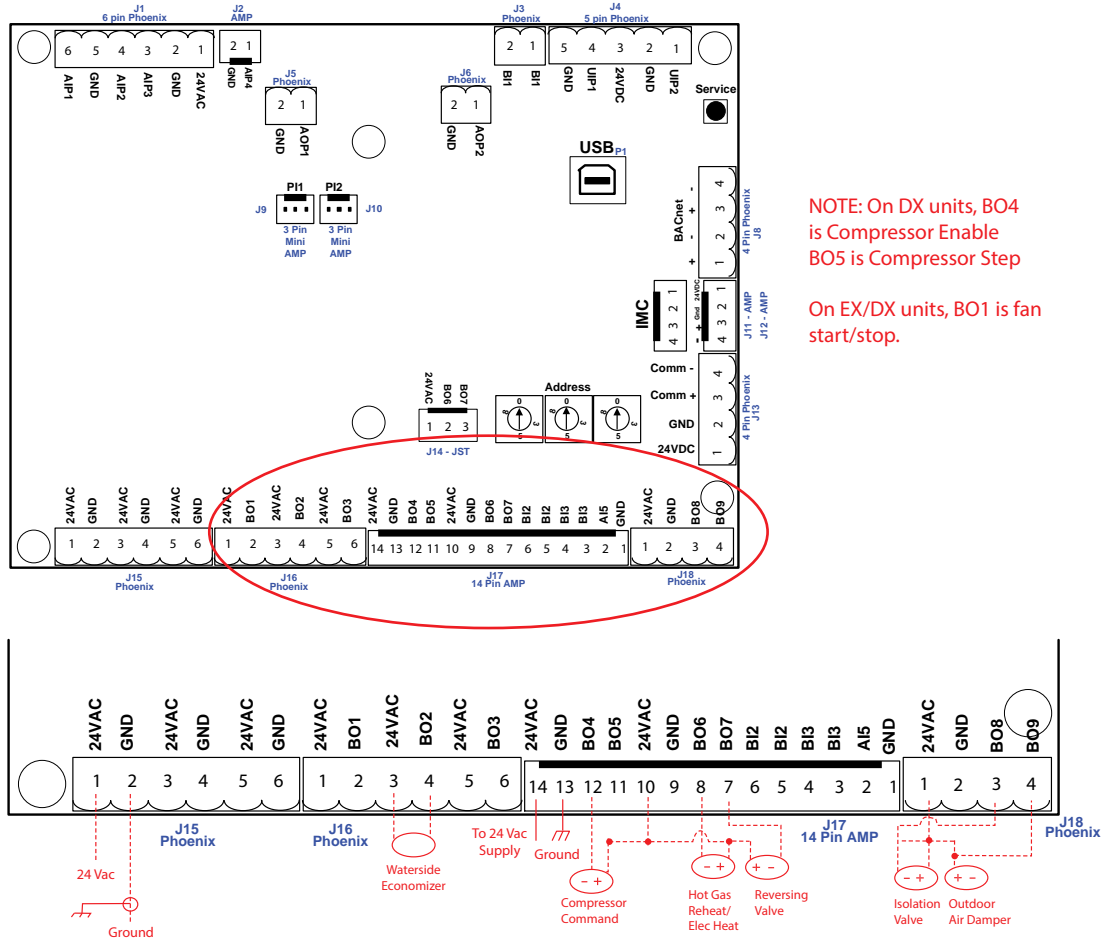
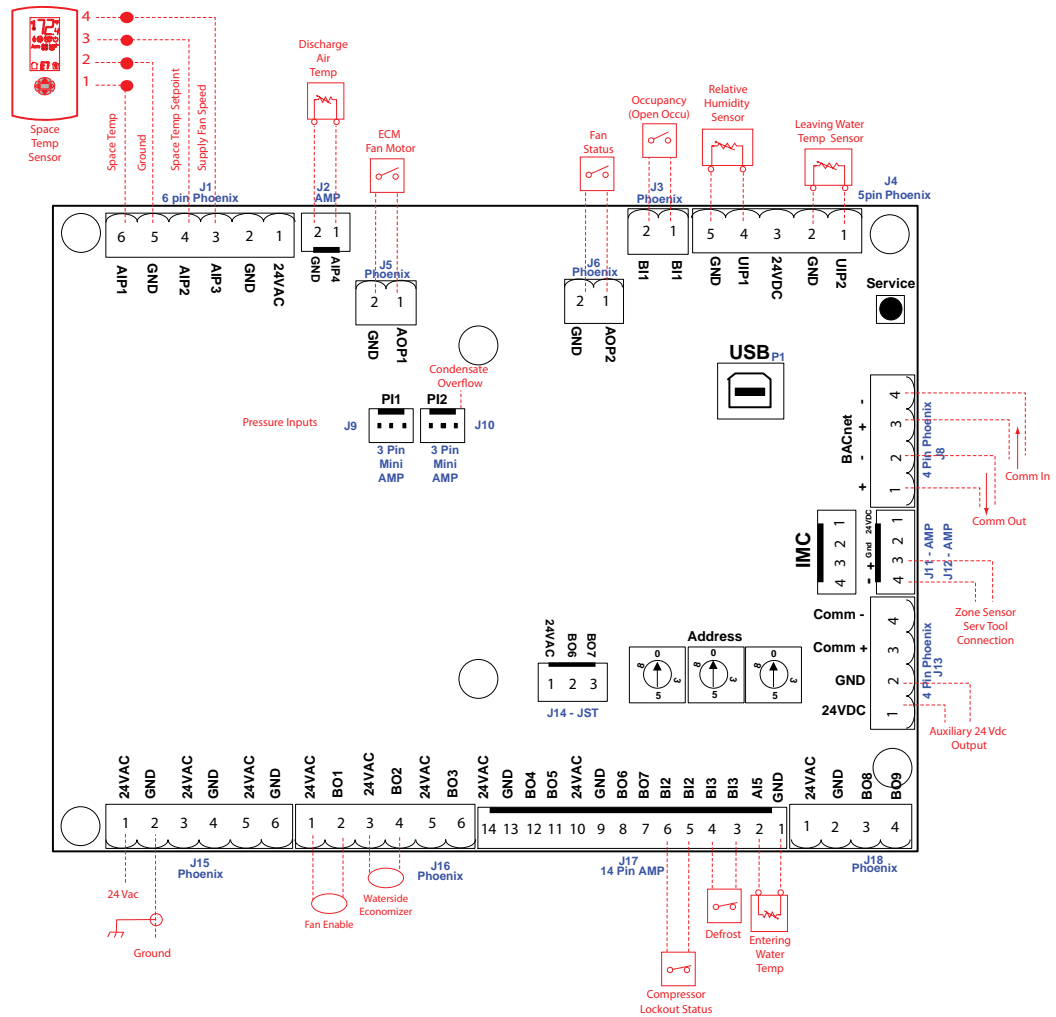

Figure 11. Common input/sensor connections for EX and DX units



**Figure 12. 2-position ventilation economizer for GE units only**

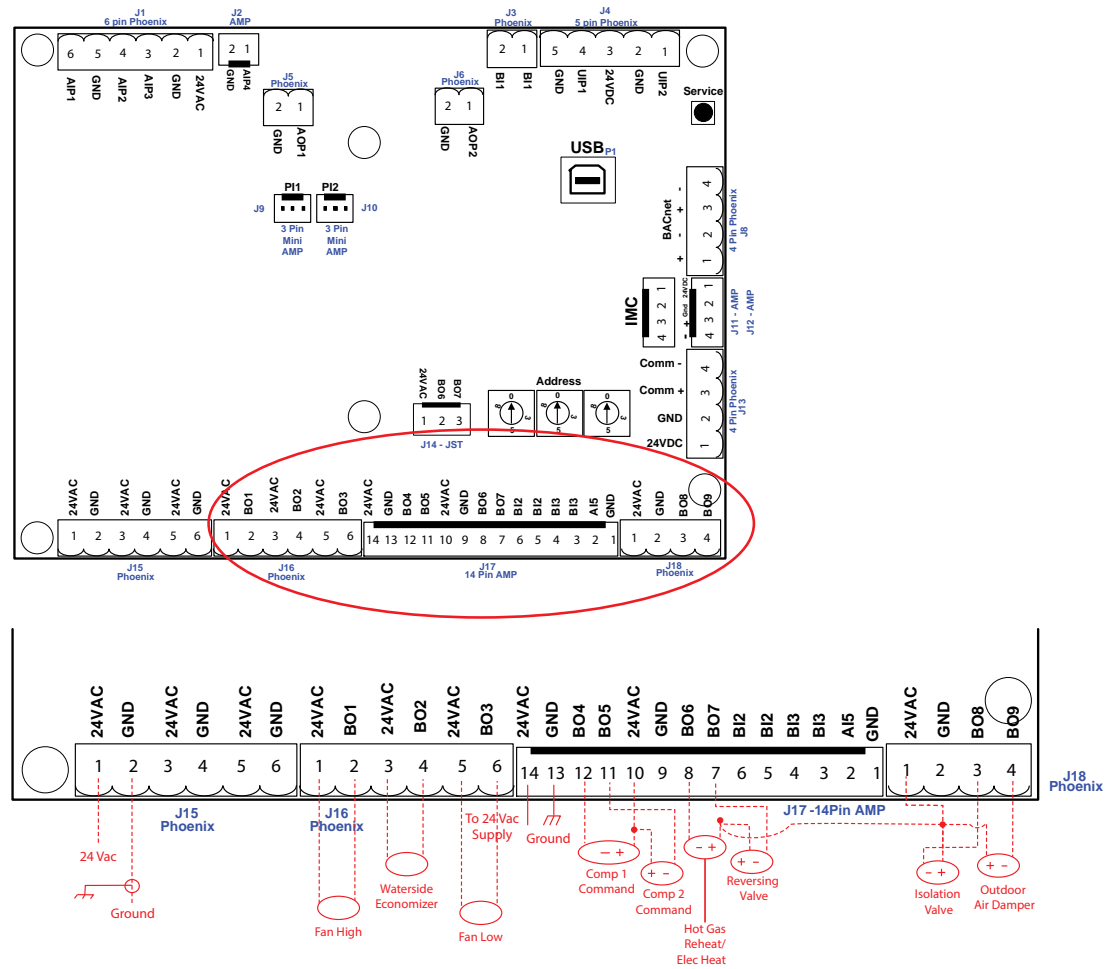
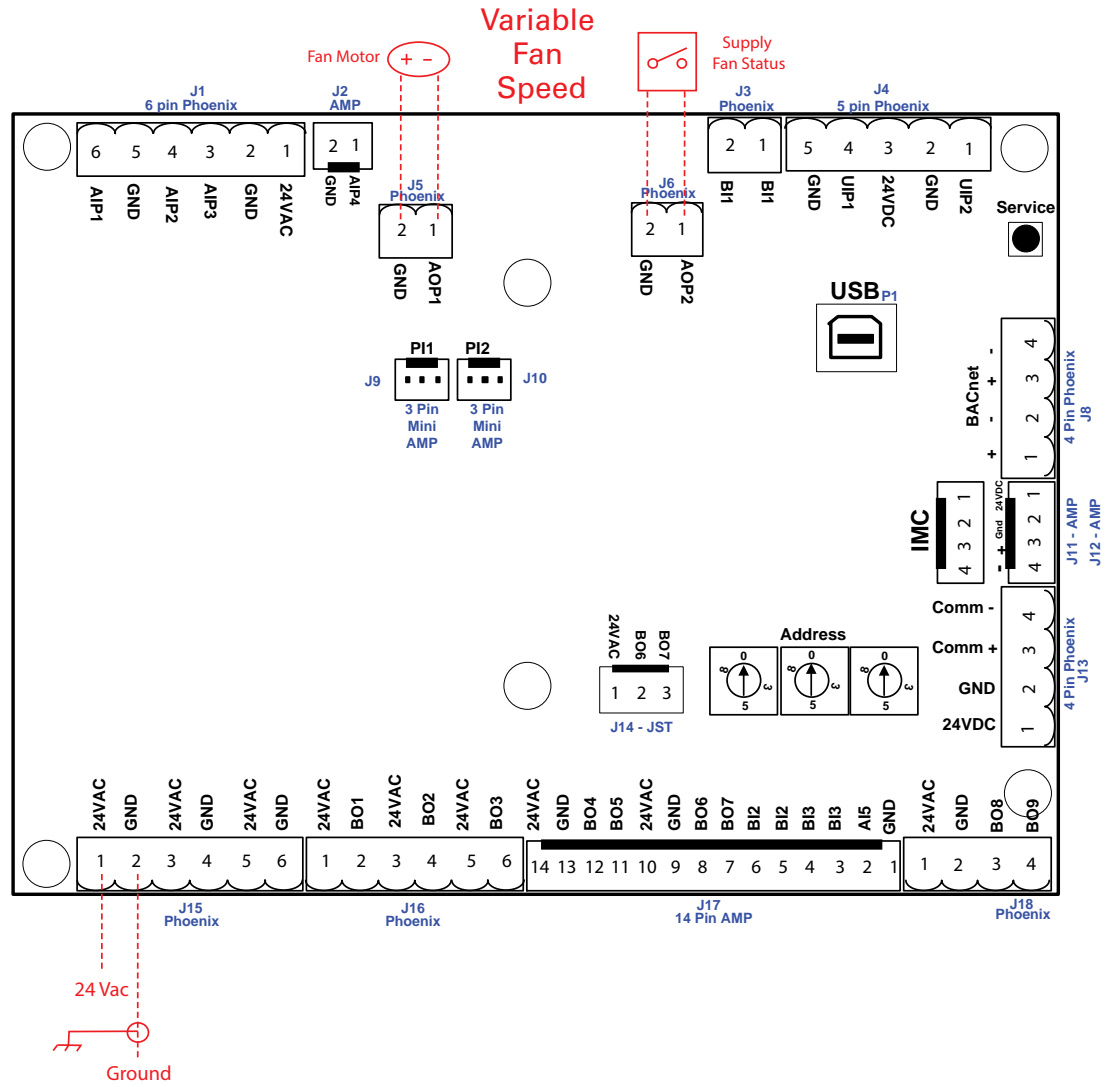

Figure 13. Variable speed supply fan





# Wiring Installation

The Symbio 400–B/500 Controller can be installed on a BACnet MS/TP link, or with the Trane® Wireless Communication Interface (WCI), which enables wireless communication. All wiring must comply with the National Electrical Code (NEC™) and local electrical codes.

## BACnet® MS/TP Communication Link

For more details about BACnet MS/TP communication link, refer to the *BACnet MS-TP Wiring and Link Performance Best Practices and Troubleshooting Guide* (BAS-SVX51).

### **⚠ WARNING**

#### **Proper Field Wiring and Grounding Required!**

**Failure to follow code could result in death or serious injury.**

**All field wiring MUST be performed by qualified personnel. Improperly installed and grounded field wiring poses FIRE and ELECTROCUTION hazards. To avoid these hazards, you MUST follow requirements for field wiring installation and grounding as described in NEC and your local/state/national electrical codes.**

## BACnet/IP Over Wired Ethernet Communications

Wired Ethernet is only an option on the Symbio 500 controller. Use daisy chain, star, or ring topologies.

## BACnet/IP Over Wi-Fi Communications

Symbio 500 can communicate wirelessly through an optional Trane Wi-Fi module on the USB port.

- X13651743001 Wi-Fi Field Installed Kit, 1 m cable, 70C
- X13651743002 Wi-Fi Field Installed Kit, 2.9 m cable, 70C

## Air-Fi Wireless BACnet® Communications

Symbio 400–B/500 can communicate wirelessly to the Trane Tracer SC+ and zone sensors through the Trane Air-Fi Wireless system (BACnet/Zigbee). Wireless Air-Fi communications are the preferred method of communicating to the SC+. Trane Air-Fi is a factory or field installed option.

See Air-Fi Wireless System IOM BAS-SVX40\*-EN for detailed information.

## Wiring Guidelines for Wired BACnet MS/TP

- Use 18 AWG Trane purple-shielded communication wire for BACnet installations.
- Link limit of 4,000 ft and 60 devices maximum (without a repeater).
- Use a Trane BACnet termination on each end of the link.
- Use daisy chain topology.
- Maintain polarity.

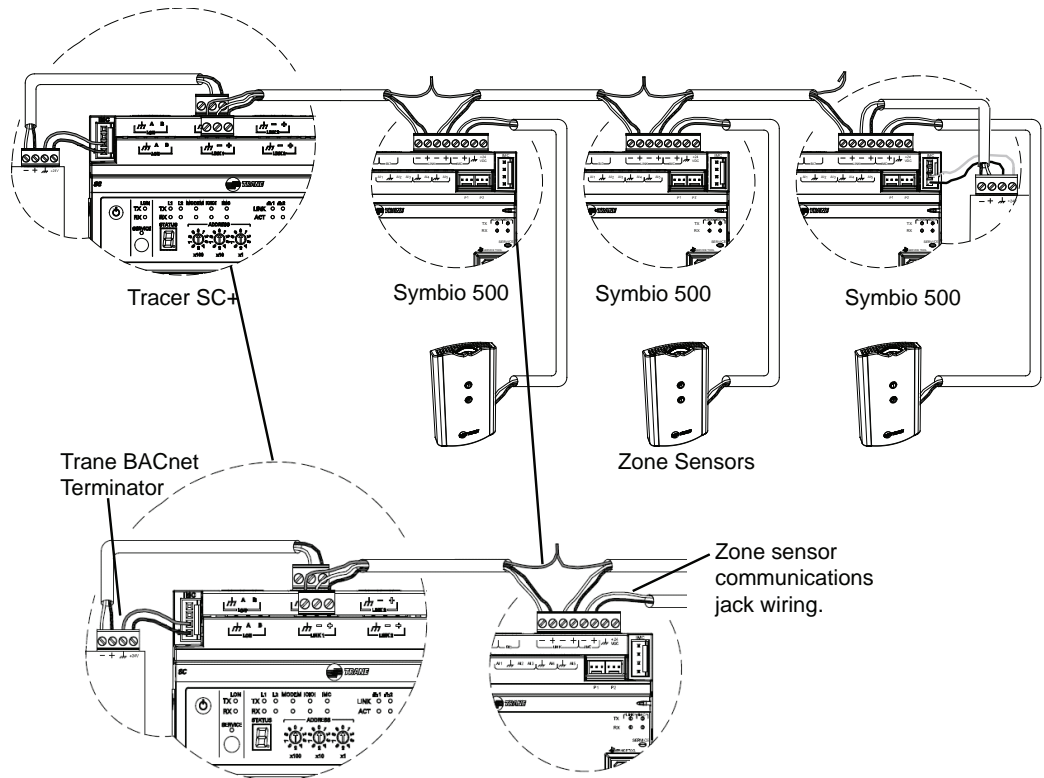
**Figure 14. BACnet MS/TP link wiring**

## Wiring Best Practices

To ensure proper network communication, follow the recommended wiring and best practices below when installing communication wire:

- All wiring must comply with the National Electrical Code™ (NEC) and local codes.
- Ensure that 24 Vac power supplies are consistent in regards to grounding. Avoid sharing 24 Vac between controllers.
- Avoid over tightening cable ties and other forms of cable wraps. This can damage the wires inside the cable.
- Do not run communication cable alongside or in the same conduit as 24 Vac power. This includes the conductors running from TRIAC-type inputs.
- In open plenums, avoid running wire near lighting ballasts, especially those using 277 Vac.
- Use same communication wire type, without terminators, for the zone sensor communication stubs from the Symbio 500 controller IMC terminals to the zone sensor communication module.
- Zone Sensor communication wiring length limits of 300 ft. (100 m).

## Setting Up the Controller on a BACnet Link

Observe the following when setting up the Symbio 500 controller on a BACnet link.

- Use 18 AWG shielded communication wire for BACnet MS/TP installations.
- Limit BACnet MS/TP wiring links to 4,000 ft. There is a maximum of 60 devices per link (*without a repeater*).
- Three (3) BACnet links are available on the Tracer SC+.
- Connect the BACnet link to the Symbio 500 controller terminals labeled *Link* as shown on the right. Incoming wires can be connected to the first two terminals, and the outgoing wires can be connected to the second set of terminals, so there is only one wire per termination.

Figure 15. Symbio 500 BACnet links

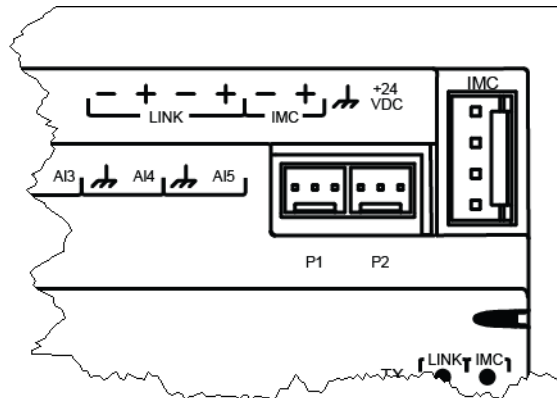

## Setting the Address

The three (3) rotary address dials on the Symbio 500 serve one or two purposes depending upon the network: they are always used for the MAC Address, which is sometimes all or part of the BACnet Device ID.

Figure 16. Setting the rotary address

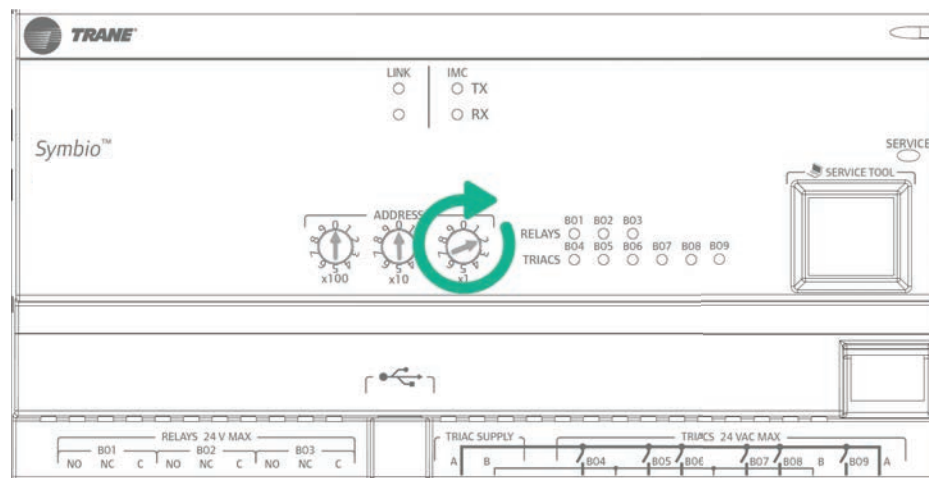

Use a 1/8 inch (3.2 mm) flathead screwdriver to set rotary address dials. These dials rotate in either direction.

### MAC Address

The MAC Address is required by the RS-485 communication protocol on which BACnet operates. Valid MAC addresses are 001 to 127 for BACnet.

**Important:** Each device on the link must have a unique MAC Address/Device ID. A duplicate address or a 000 address setting will interrupt communications and cause the Tracer SC+ device installation process to fail.

### BACnet Device ID

The BACnet Device ID is required by the BACnet network. Each device must have a unique number from 001 to 4094302.

## BACnet Networks Without a Tracer SC+ System Controller

On BACnet networks without a Tracer SC+ system controller, the Device ID can be assigned one of two ways:

- It can be the same number as the MAC Address, determined by the rotary address dials on the Symbio 500 controller. For example, if the rotary address dials are set to 042, both the MAC Address and the BACnet Device ID are 042, **OR**
- It can be soft set using Tracer TU service tool. If the BACnet Device ID is set using Tracer TU service tool, the rotary address dials only affect the MAC Address, they do not affect the BACnet Device ID.

## BACnet Networks With a Tracer SC+ System Controller

On BACnet networks with a Tracer SC system controller, the Device ID for the Symbio 500 controller can be soft set by the system controller using the following scheme.

**Note:** *The BACnet Device ID is displayed as the Software Device ID on the Tracer TU Controller Settings Page in the Protocol group.*

### Device ID Assignment for BACnet MS/TP Devices

Each unit controller must have a unique BACnet device ID. Tracer SC+ automates the process by calculating a unique device ID for each unit controller and then saving the device ID to memory in each device. BACnet MS/TP device IDs are calculated using the following three sets of values:

- The Tracer SC+ rotary switch value (1 to 419)
- The Tracer SC+ BACnet MS/TP link number (1 to 3)
- The unit controller rotary switch value (1 to 127)

The three values are joined together to form the BACnet device ID for the unit controller as shown in the following table.

**Table 8. Calculating the BACnet Device ID**

Tracer SC+ rotary switch value (21)	0	2	1				
Tracer SC+ BACnet MS/TP link number (1)				1			
Unit controller MAC address (38)					0	3	8
BACnet Device ID: 211038	0	2	1	1	0	3	8

## Ethernet

The Symbio 500 controller has two Ethernet ports. The ports, labelled 1 and 2, are internally connected as one port. These ports enable wired BACnet/IP or support for the TD7 display.

For more information on BACnet/IP wiring refer to BACnet®/IP Wiring and Best Practices Application Guide (BAS-APG046\*–EN).

Example Application: Dual Duct VAV where wired BACnet/IP is specified.



**Figure 17. Symbio 500 Ethernet ports**

## Power Supply

### ⚠ WARNING

#### Hazardous Voltage!

Failure to disconnect power before servicing could result in death or serious injury. Disconnect all electric power, including remote disconnects before servicing. Follow proper lockout/tagout procedures to ensure the power can not be inadvertently energized. Verify that no power is present with a voltmeter.

### ⚠ WARNING

#### Proper Ground Connection Required!

Failure to follow instructions below could result in death or serious injury. After installation, ensure that the 24 Vac transformer is grounded through the controller. Measure the voltage between chassis ground and any ground terminal on the controller. Expected result: Vac <4.0 volt.

### NOTICE

#### Equipment Damage!

Sharing 24 Vac power between controllers could result in equipment damage.

A separate transformer is recommended for each Symbio 400-B/500 controller. The line input to the transformer must be equipped with a circuit breaker sized to handle the maximum transformer line current. If a single transformer is shared by multiple Symbio 400-B/500 controllers:

- The transformer must have sufficient capacity.
- Polarity must be maintained for every Symbio 400-B/500 controller powered by the transformer.

**Important:** If the polarity is inadvertently reversed between two controllers powered by the same transformer, a difference of 24 Vac will occur between the grounds of each controller, which can result in:

- Partial or full loss of communication on the entire BACnet MS/TP link.
- Improper function of Symbio controller outputs.
- Damage to the transformer or a blown transformer fuse.



### Transformer Recommendations

The Symbio 400-B/500 controller can be powered with 24 Vac or 24 Vdc. You must use a 24 Vac power supply for proper operation of the binary inputs, which require 24 Vac detection, and also to use the spare 24 Vac outputs to power relays and TRIACS.

- **AC transformer requirements:** UL listed, Class 2 power transformer, 24 Vac  $\pm 15\%$ , device max load 24 VA, BCI application 6 VA. The transformer must be sized to provide adequate power to the controller (21 VA) and outputs (maximum of 10A per relay output and 0.5A per TRIAC output).
- **DC power supply requirements:** UL listed, Class 2 power supply, 24 Vdc  $\pm 15\%$ , device max load 420 mA, BCI application 90 mA.
- **CE-compliant installations:** The transformer must be CE marked and SELV compliant per IEC standards.

### Wiring Recommendations

To ensure proper operation of the Symbio 400-B/500 controller, install the power supply circuit in accordance with the following guidelines:

- The controller must receive AC power from a dedicated power circuit; failure to comply may cause the controller to malfunction.
- A dedicated power circuit disconnect switch must be near the controller, easily accessible by the operator, and marked as the disconnecting device for the controller.
- DO NOT run AC power wires in the same wire bundle with input/output wires; failure to comply may cause the controller to malfunction due to electrical noise.
- 18 AWG (0.823 mm<sup>2</sup>) copper wire is recommended for the circuit between the transformer and the controller.

### Connecting Wires

Disconnect power to the transformer and then ground one of the terminals on the controller to the enclosure (if the enclosure is adequately grounded) or to an alternate earth ground.

Figure 18. Symbio 400-B/500 transformer

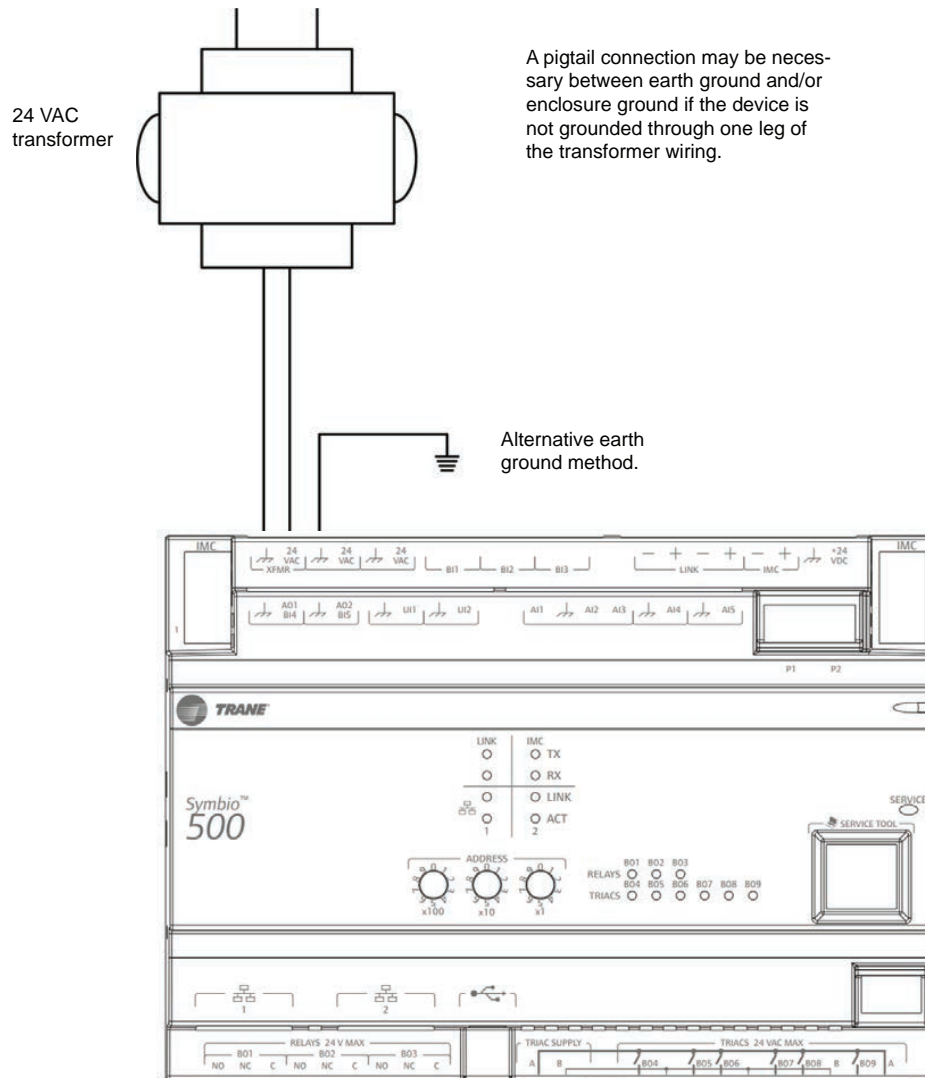

### Power On Check

1. Verify that the 24 Vac connector and the chassis ground are properly wired.
2. Remove the lockout/tagout from the line voltage power to the electrical cabinet.
3. Energize the transformer to apply power to the Symbio controller.
4. Observe the Symbio controller when power is applied to verify the power check sequence:
  - a. The power LED lights red for 1 second.
  - b. The power LED lights green.
  - c. If the sequence completes as described, the controller is properly booted and ready for the application code.
  - d. If the power LED flashes red, a fault condition exists.



# LEDs

## LED Locations

The Symbio controllers have the following LEDs located on the front (refer to the following illustration):

- Marquee LED
- Communication Status LEDs and IMC Status LEDs
- Service Button LED
- Binary Output Relay (3)/TRIAC (9) Status LEDs (only the Symbio 400–B)

**Figure 19. Symbio 500 LED locations**

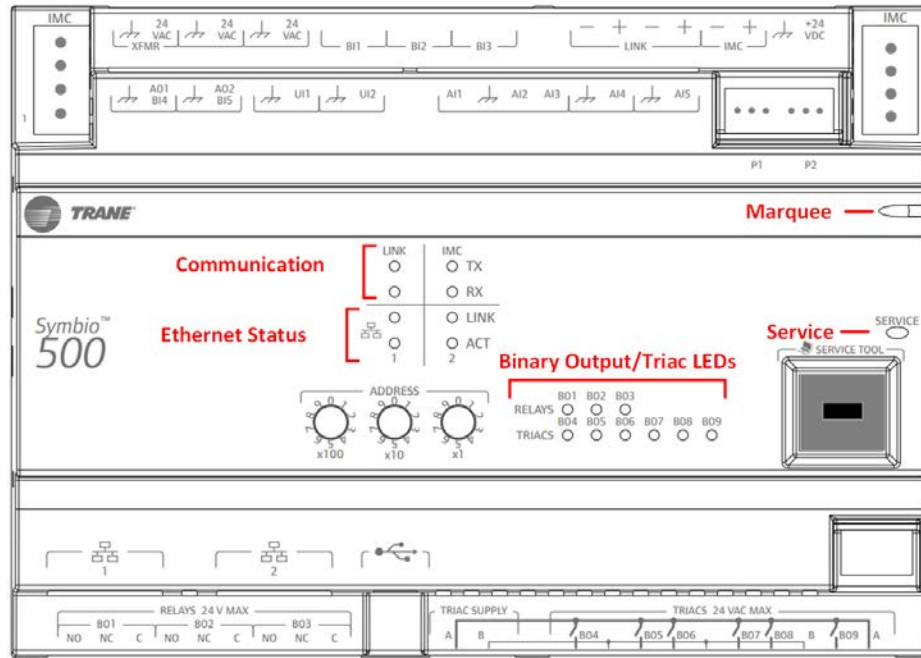

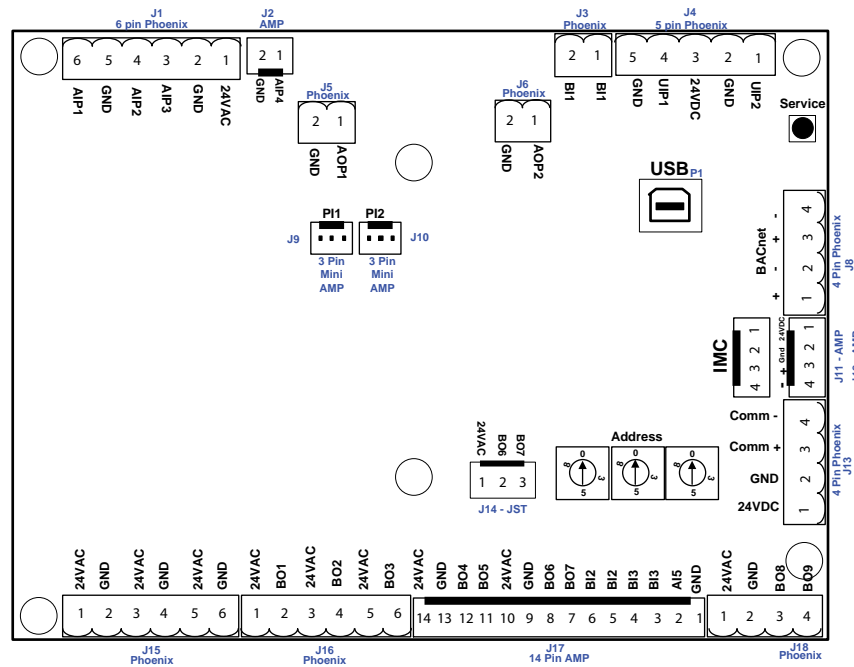
**Figure 20. Symbio 400/B LED Locations**

## LED Descriptions, Activities, and Troubleshooting

The following table provides a description of LED activity, an indication or troubleshooting tip for each, and any relative notes.

**Table 9. LED activities and troubleshooting tips**

LED Name	Activities	Indication and Troubleshooting Tips	Notes
Marquee LED	Shows solid green when the unit is powered and no alarm exists.	Indicates normal operation	When powering the Symbio 400–B/500 and expansion module, the Marquee LED will blink RED, blink GREEN (indicating activated and controller/expansion module are communicating), and then stay GREEN CONTINUOUSLY (indicating normal power operation).
	Shows blinking green during a device reset or firmware download.	Indicates normal operation	
	Shows solid red when the unit is powered, but represents low power or a malfunction.	<ul style="list-style-type: none"> <li>If low power; could be under voltage or the microprocessor has malfunction. Follow the troubleshoot procedure “24 Vac Measurement,” p. 46 to measure for the expected value range. In addition, see Table 4, p. 24, for a list of 24 Vac draws.</li> <li>If malfunction; un-power and then re-power unit to bring the unit back up to normal operation.</li> </ul>	
	Shows blinking red when an alarm or fault exists.	An alarm or fault condition will occur if the value for a given point is invalid or outside the configured limits for the point. Alarm and fault conditions vary, and they can be configured by the programmer.	
	LED not lit.	Indicates power is OFF or there is a malfunction.  OFF or malfunction; cycle the power.	

**Table 9. LED activities and troubleshooting tips (continued)**

Link and IMC	TX blinks green.	Blinks at the data transfer rate when the unit transfers data to other devices on the link.	TX LED: Regardless of connectivity or not, this LED will constantly blink as it continually looks for devices to communicate to.  LED not lit: Determine if, for example, a Tracer Synchrony or BACnet device is trying to talk to the controller or if it is capable of talking to the controller. Also determine if the communication status shows down all of the time. In addition, check polarity and baud rate.
	RX blinks yellow.	Blinks at the data transfer rate when the unit receives data from other devices on the link.  ON solid yellow; indicates there is reverse polarity.	
	LED is not lit.	Indicates that the controller is not detecting communication.  Not lit; cycle the power to reestablish communication.	
Service	Shows solid green when the LED has been pressed.		When the Symbio 400–B/500 is placed into boot mode, the system will not run any applications such as trending, scheduling, and TGP2 runtime. The controller will be placed into boot mode if the service pin is held in when power is applied. In boot mode, the controller is non-operational and is waiting for a new main application to be downloaded.
	LED not lit.	Indicates controller is operating normally.	
Binary B01 through B09	Shows solid yellow.	Indicates a corresponding binary output has been commanded ON <ul style="list-style-type: none"> <li>Relay coil; indicates that a command has been made to energize</li> <li>TRIAC; indicates that a command has been made to turn ON.</li> </ul>	If the user is currently powering the Symbio 400–B/500 from a USB port, the Led lights will turn ON. However, the binary outputs will not be activated.  Commanded ON; As an example of commanded ON, a command could be a manual command such as an override or a command could be from TGP2 based on a list of conditions that are met telling these outputs to turn ON.  LED not lit: Did the user command it to be ON? If yes, see the Marquee LED at the top of this table.
	LED not lit.	Indicates that a relay output is de-energized or no power to the board  Not lit; cycle power to reestablish communication.	

## Marquee LED Status and Error Codes

Each of the following codes is a two digit number following this pattern: First digit, 600mS pause, Second digit, 2 second pause and then repeat the pattern.

**Table 10. Marquee LED status and error codes**

LED Blink Pattern	Message	Description	Action by User
<b>Green LED Blink Pattern</b>			
Solid green light	No active alarms or messages		None - normal operation
11	Load Field	Attempting to load the field kernel and device tree from NAND flash.	None- normal operation
13	Boot Field	Successfully loaded the field images and are attempting to boot.	None- normal operation
14	Load Recover	Attempting to load the recover image from NAND flash.	None- normal operation
16	Boot Recover	Successfully loaded the recovery image and are attempting to boot.	None- normal operation
17	Recovery	Successfully booted into the recovery partition.	None- normal operation

**Table 10. Marquee LED status and error codes (continued)**

LED Blink Pattern	Message	Description	Action by User
23	Field Format	Reformatting the field file system.	None- normal operation
28	Starting Update	Starting the firmware update process.	None- normal operation
29	Locating Firmware File	Attempting to locate a firmware update file.	None- normal operation
33	Validating Firmware	Validating the signature on the firmware update file.	None- normal operation
35	Decrypting Firmware	Decrypting the firmware update file.	None- normal operation
36	Update Success	Done performing the firmware update.	None- normal operation
37	Clearing Database	Clearing the database.	None- normal operation
38	Validating Firmware	Validating the signature on the firmware update file.	None- normal operation
41	Decrypting Firmware	Decrypting the firmware update file.	None- normal operation
43	Restoring Backup	Restoring a database backup.	None- normal operation
45	Force Database Clear	The user has 30 seconds to set the rotaries to something other than 9-9-9 to start the process of returning to factory defaults.	None- normal operation
46	Clear Done	Done returning the database to factory defaults.	None- normal operation
47	Done	Done returning whatever process was started (usually a forced recovery partition update).	None- normal operation
51	Backup Retored	Database backup has been restored.	None- normal operation
52	Updating Firmware	Updating the firmware.	None- normal operation
53	Firmware Updated	Firmware was updated.	None- normal operation
55	Updating Firmware	Firmware is currently being updated.	None- normal operation
56	Updating Kernel	The kernel is currently being updated.	None- normal operation
58	Updating Device Tree	The kernel is currently being updated.	None- normal operation
61	Updating Bootloader	The bootloader is being updated.	None- normal operation
63	Updating Recovery	The recovery file system is being updated.	None- normal operation
<b>Red LED Blink Pattern</b>			
12	Load Field Fail	Attempted load of the field kernel or device tree failed.	<ol style="list-style-type: none"> <li>Thumb drive with .scfx file, power down, set address rotaries to 991, and power up.</li> <li>Replace controller.</li> </ol>
15	Load Recovery Fail	Attempted load of the recovery image failed.	Replace controller
18	Field Mount Fail	Failed to mount the field partition during a firmware update attempt.	<ol style="list-style-type: none"> <li>Thumb drive with .scfx file, power down, set address rotaries to 991, and power up.</li> <li>Replace controller.</li> </ol>
19	Bad Switch Setting	Rotary switches are set to a bad/unknown value.	Contact technical support.
21	Bad Firmware File	Unable to mount the firmware update file.	Download firmware file again and retry download.
22	Firmware Not Compatible	Firmware file downloaded is not compatible with this hardware.	Download the correct FW file for the controller.
24	Field Format Fail	Failed to reformat the field file system.	Replace controller.
25	Field Attach UBI Fail	Failed to attach (UBI) to the field file system.	Replace controller.

**Table 10. Marquee LED status and error codes (continued)**

LED Blink Pattern	Message	Description	Action by User
26	Field Mount Fail	Failed to mount the field file system.	Replace controller.
27	Bad Update Method	Don't know what our update method is.	Contact technical support.
31	No Firmware File Found	Unable to find a firmware update file.	Thumb drive has no .scfx file. .scfx file must be located at the root of the USB drive.
32	Multiple Firmware Found	Multiple firmware update files were found.	Too many .scfx files on the thumb drive. Can only have on .scfx file and must be located in the root of the USB drive.
34	Firmware Invalid		Download the firmware file again and retry download.
39	Firmware Invalid		Download the correct FW file again and retry download.
42	Bad Firmware File	Unable to mount the firmware update file.	Download the firmware file again and retry download.
44	Restore Failed	Database restore failed for some reason.	Try to restore using a different backup file (Restore file may be corrupt).
48	Hold	Crashed too many times and are now "holding."	Contact technical support.
49	Abnormal Termination	The embedded application terminated abnormally.	Contact technical support.
54	Firmware Not Compatible	The firmware file downloaded is not compatible with this hardware.	Download the correct FW file for the controller.
57	Kernel Update Failure	Failed to update the kernel.	<ol style="list-style-type: none"> <li>1. Try upgrading the controller firmware again</li> <li>2. Replace controller.</li> </ol>
59	Device Tree Failure	Failed to update the kernel device tree.	Not applicable for 210, 400-B, or 600.
62	Bootloader Failure	Failed to update the bootloader.	<ol style="list-style-type: none"> <li>1. Try upgrading the controller firmware again</li> <li>2. Replace controller.</li> </ol>
64	Recovery Failure	Failed to update the recovery file system.	<ol style="list-style-type: none"> <li>1. Try upgrading the controller firmware again</li> <li>2. Replace controller.</li> </ol>





# Sequence of Operations

The Symbio 400–B/500 Controller operates to maintain the space temperature setpoint.

## Power-up Sequence

1. The following sequence occurs when 24 Vac power is initially applied to the Symbio 400–B/500 Controller:
  - The Power Marquee LED turns on as red, then
  - Flashes green, and then
  - Stays lit as constant green.
2. All outputs are controlled OFF.
3. The controller reads all input local values to determine initial values.
4. The random start timer begins.
5. The random start timer expires.
6. Normal operation begins, assuming there are no generated diagnostics. If any points are in fault or alarm mode, the Power Marquee LED flashes red.

**Important:** *Flashing red does not indicate that the Symbio 400–B/500 Controller fails to operate. Instead, the point(s) that are in fault or alarm mode should be checked to determine if the status of the point(s) is acceptable to allow equipment operation.*

## Random Start

Random start prevents all units in a building from energizing at the same time. The random start timer delays the fan and any heating or cooling startup from 5 to 30 seconds.

## Occupancy Modes

Occupancy modes can be controlled by the following methods:

- The state of the local (hard wired) occupancy binary input BI1.
- A timed override request from a Trane zone sensor.
- A communicated signal from either a Tracer SC+ or BAS.

A communicated request, from either a Tracer SC+ or BAS, takes precedence over local requests. If a communicated occupancy request has been established and is no longer present, the controller reverts to the default (occupied) occupancy mode after 15 minutes (if no hard wired occupancy request exists). The Symbio 400–B/500 controller includes the following occupancy modes:

- Occupied
- Unoccupied
- Occupied Standby
- Occupied Bypass

**Table 11. Occupancy modes**

Occupancy Request (MV/6)	Occupancy Input (B/1)	TOV Initiated	Resultant Occupancy–Occupancy Status (MV/7)
Occupied	Occupied	X <sup>(a)</sup>	Occupied
	Unoccupied	Yes	Occupied Standby
		No	Bypass
Occupied Bypass	Occupied	X	Occupied
	Unoccupied	No	Occupied Standby
		Yes	Occupied Bypass
Unoccupied	X	No	Unoccupied
		Yes	Occupied Bypass
Occupied Standby	X	No	Occupied Standby
		Yes	Occupied Bypass
Auto	Occupied	X	Occupied
	Unoccupied	No	Unoccupied
		Yes	Occupied Bypass
Out of Service = True	Occupied	X	Occupied
	Unoccupied	No	Unoccupied
		Yes	Occupied Bypass

<sup>(a)</sup> Not recognized by the point as important.

## Occupied Mode

In Occupied Mode, the Symbio 400–B/500 controller maintains the space temperature based on the occupied space temperature setpoint ± occupied offset. When occupied, the fan can be configured to operate continuously (default) or cycle ON/OFF with demand, based on BV/1 (Supply Fan Configuration Command). The controller uses the occupied mode as a default mode when other forms of occupancy requests are not present. The outdoor air damper, if present, closes when the fan is OFF. The temperature setpoints can be local (hard wired), communicated, or stored default values (configured using the Tracer TU service tool).

## Unoccupied Mode

In unoccupied mode, the Symbio 400–B/500 controller attempts to maintain the space temperature based on the unoccupied heating or cooling setpoint. The fan cycles between HIGH speed and OFF. In addition, the outdoor air damper remains closed, unless economizing. The controller always uses the stored default setpoint values (configured using the Tracer TU service tool), regardless of the presence of a hard wired or communicated setpoint value.

## Occupied Standby Mode

The Symbio 400–B/500 controller is placed in occupied standby mode only when a communicated occupied request is combined with an unoccupied request from occupancy binary input B11. In occupied standby mode, the controller maintains the space temperature based on the occupied space temperature setpoint, +/- the occupied standby offset (default 7.5°F). Because the occupied standby setpoints have a wider spread than the standard occupied setpoints and the outdoor air damper is closed, the occupied standby mode reduces the demand for heating and cooling the space. The fan runs as configured for occupied mode.

## Occupied Bypass Mode

The Symbio 400–B/500 controller is placed in occupied bypass mode when:

- The controller is operating in the unoccupied mode and the timed override ON button on the Trane zone sensor is pressed (see Timed Override Control below).
- The controller receives an occupied bypass signal from a BAS.

In occupied bypass mode, the controller maintains the space temperature based on the occupied heating or cooling setpoints. The fan runs as configured (continuous or cycling). The outdoor air damper closes when the fan is OFF. The controller remains in occupied bypass mode until either the CANCEL button is pressed on the Trane zone sensor or the occupied bypass time expires (configured using the Tracer TU service tool). The temperature setpoints can be configured as local (hard wired), communicated, or stored default values using the Tracer TU service tool.

## Timed Override Control

If the zone sensor has a timed override option (ON/CANCEL buttons), pushing the ON button initiates a timed override on request. A timed override upon request changes the occupancy mode from unoccupied mode to occupied bypass mode. In occupied bypass mode, the controller controls the space temperature based on the occupied heating or cooling setpoints. The occupied bypass time, which defines the duration of the override and resides in the controller, is configured from 0 to 240 minutes (default value of 120 minutes). When the occupied bypass time expires, the controller transitions from occupied bypass mode to unoccupied mode.

Pushing the CANCEL button cancels the timed override request. In addition, it ends the timed override before the occupied bypass time has expired and transitions the unit from occupied bypass mode to unoccupied mode. If the controller is in any mode other than unoccupied mode when the ON button is pressed, it still starts the occupied bypass timer without changing to occupied bypass mode. If the controller is placed in unoccupied mode before the occupied bypass timer expires, it is placed into occupied bypass mode and remains in this mode until either the CANCEL button is pressed on the Trane zone sensor or the occupied bypass time expires.

## Heat/Cool Operation

### Cooling

During the cooling mode, the Symbio 400–B/500 controller uses one of the following cooling modes to maintain the space temperature at the active cooling setpoint:

- Occupied Cooling
- Occupied Standby Cooling
- Unoccupied Cooling

The Symbio 400–B/500 controller uses the measured space temperature and the active cooling setpoint along with the control algorithm, to determine the requested cooling capacity of the unit (0-100%). The outputs are controlled based on the unit configuration and the requested cooling capacity.

**Note:** If humidity control is enabled, refer “Other Modes,” p. 49.

### Heating

During the heating mode, the Symbio 400–B/500 controller uses one of the following heating modes to maintain the space temperature at the active heating setpoint:

- Occupied Heating
- Occupied Standby Heating
- Unoccupied Heating

The Symbio 400–B/500 controller uses the measured space temperature and the active heating setpoint, along with the control algorithm, to determine the requested heating capacity of the unit (0-100%). The outputs are controlled based on the unit configuration and the requested heating capacity.

## Fan Operation

The Symbio 400–B/500 controller can be configured to operate as a 1- or 2-speed fan or as a variable speed fan in a Single Zone VAV. When the fan is in any occupied mode (including standby and bypass), the fan can be set up to cycle with heat/cool demand or to continuously run regardless of demand. The fan defaults to continuous operation, but can be adjusted by toggling BV/1 Supply Fan Configuration Command. When the fan is in unoccupied mode, the fan turns on only when the unoccupied setpoints



## Sequence of Operations

---

are not being met. The fan mode request can be either communicated through a BAS or hard wired to the controller from a fan switch. In all configurations, the fan can be controlled off when the manual output test has been initiated or a latching diagnostic is present.

### Single-Zone VAV/Variable Speed Fan Operation

When configured with a variable speed fan, the Symbio 400–B/500 controller treats all active fan mode request (with the exception of OFF) as AUTO. When in AUTO, the controller ramps up the fan as necessary between the lowest and highest speeds in order to meet the demand of the space or in order to satisfy minimum airflow setting of the unit for specific heating/cool modes (whichever is higher). The setpoints below can be adjusted as necessary to meet individual specifications. The following setpoints cannot be configured below the lowest possible speed of the fan:

- **AV/20 Supply Fan Speed Ventilation:** when configured for continuous operation, this is the speed at which the fan operates when heating and cooling stages are not active.
- **AV/19 Supply Fan Speed First Stage Minimum:** the lowest speed the fan operates when in the first stage of heating or cooling. The fan ramps up from this point as necessary to meet demand. Capacity must be at 100% for 10 minutes before the fan will ramp to AV/17 setting.
- **AV/17 Supply Fan Speed Maximum Heat Cool Capacity:** When electric heat is not active, or a single stage of compressor is active, the fan modulates between AV19 and AV17 to meet demand. When electric heat is active or the second stage of compressor is active the fan will run at AV17.
- **AV/18 Supply Fan Speed Dehumidification:** the speed the fan operates in the active dehumidification mode.

### Constant Torque ECM Fans

On vertical models of EX and DX units in ½ Ton to 6 Ton sizes the supply fans are shipping from the factory programmed as Constant Torque instead of Constant CFM. This change is represented with a letter “G” as the 4th digit of the model number.

The Constant Torque fans use the same control logic in the controller, but the fan motors are programmed differently and are not interchangeable with the Constant CFM versions. The settings for the fan parameters in the controller must be set correctly to ensure proper equipment operation. Refer to [Table 12, p. 45](#) for proper settings.

If adjustments are made to the maximum fan speed (AV17 Supply Fan Speed Maximum Heat Cool Capacity), then the scaling factor (AV22 Supply Fan Scaling Factor) will be used to recalculate the default values for the low setting (AV18 Supply Fan Speed Dehumidification, AV19 Supply Fan Speed First Stage Minimum, and AV20 Supply Fan Speed Ventilation). AV20 Supply Fan Speed Ventilation is the only low setting that can be adjusted from the default settings and if adjusted by the user the factory recalculation will not take effect.

#### Notes:

- *Constant Torque ECM Fans are supported on Symbio 400–B/500 controllers.*
- *On Constant Torque ECM Fan motors a 0% signal represents Off. On Constant CFM ECM Fan motors a 0% signal represents low speed.*

**Table 12. Constant torque supply fan default settings**

Efficiency	Size	High Setting AV17	Low Setting AV18, AV19, or AV20 (Mode Dependent)	Minimum Setting	Scaling Factor AV22
Standard Efficiency	GEVG 006	60%	30%	20%	0.5
	GEVG 009	60%	30%	20%	0.5
	GEVG 012	60%	30%	20%	0.5
	GEVG 015	60%	30%	20%	0.5
	GEVG 018	60%	30%	20%	0.5
	GEVG 024	60%	30%	20%	0.5
	GEVG 030	60%	30%	20%	0.5
	GEVG 036	60%	30%	20%	0.5
	GEVG 042	60%	30%	20%	0.5
	GEVG 048	60%	30%	20%	0.5
	GEVG 060	76%	38%	20%	0.5
High Efficiency	EXVG 009	60%	30%	20%	0.5
	EXVG 009	60%	30%	20%	0.5
	EXVG 009	60%	30%	20%	0.5
	EXVG 018	60%	30%	20%	0.5
	EXVG 024	60%	30%	20%	0.5
	EXVG 030	60%	30%	20%	0.5
	EXVG 036	60%	30%	20%	0.5
	EXVG 042	60%	30%	20%	0.5
	EXVG 048	60%	30%	20%	0.5
	EXVG 060	67%	34%	20%	0.5
	EXVG 070	84%	42%	20%	0.5
2 Stage High Efficiency	DXVG 024	60%	30%	20%	0.5
	DXVG 036	60%	30%	20%	0.5
	DXVG 060	67%	34%	20%	0.5
	DXVG 070	84%	42%	20%	0.5

**Notes:**

1. The minimum setting is enforced to protect equipment.
2. The full range of the PWM is scaled between 0%-100% with 20% being the minimum signal.

**Example:**

Determining low fan speeds GEVG 036 Unit:

$AV17 * AV22 = 60\% * 0.5 = 30\%$  for the factory default value applied to AV18/19/20.

If AV17 has been changed in the field to 68% the low settings will be recalculated accordingly.

$68\% * 0.5 = 34\%$  for the new default value applied to AV18/19/20.

If AV17 is adjusted in the field low enough that it causes the low settings to fall below the min setting.

$39\% * 0.5 = 19\%$  so the minimum setting of 20% will be applied as the new default to AV18/AV19/AV20.

If AV20 is overridden and AV17 is adjusted, the newly recalculated default values will not take effect on AV20 and it will continue to use the overridden value, and a manual adjustment may be required.

## 1– and 2–Speed Fan Operation

When using a 2-speed fan, the Symbio 400–B/500 controller can be configured for default operation by adjusting the Cooling Fan Speed Default and Heating Fan Speed Default. Both of these values are factory-installed and are set to AUTO.

**Table 13. Fan speed arbitration for 1–, 2–speed fans**

Inputs		Result
Supply Fan Staged Speed Setpoint BAS (MV/8)	Supply Fan Speed Setpoint Local (MI/2)	
Auto	Auto	Auto
Auto	Off	Off
Auto	Low	Low <sup>(a)</sup>
Auto	Medium	Medium <sup>(b)</sup>
Auto	High	High
Off	X <sup>(c)</sup>	Off
Low	X <sup>(c)</sup>	Low
Medium	X <sup>(c)</sup>	Medium <sup>(b)</sup>
High	X <sup>(c)</sup>	High
Invalid or not present	Invalid or not present	Auto

(a) 1–speed fan will interpret low as high.

(b) 1– and 2–speed fans interpret medium a high.

(c) Any value is applicable.

## Fan Off Delay

If the fan is configured for cycling and the heating output is controlled OFF, the Symbio 400–B/500 controller automatically holds the fan ON for an additional 30 seconds. This 30–second delay gives the fan time to blow off any residual heat from the heating source. To adjust the Fan Off Delay, use the Tracer TU service tool to change AV/9 Supply Fan Off Delay Time.

## Entering Water Temperature Sampling Function

The Symbio 400–B/500 controller samples the Entering Water Temperature (EWT) to determine proper control action for units equipped with boiler-less electric heat, or Waterside Economizer (WSE). Each unit is treated as having isolation valves, whether present or not. If the EWT is communicated to the controller through a BAS, or if sampling is not desired, it can be turned off by setting BV/9 Water Temperature Sampling Enable to disabled. If the EWT is present as a hard wired input and communicated from a BAS, the communicated value is used. When the EWT sample is used, the isolation valve is driven open for three (3) minutes and the EWT reading is recorded at that time. To avoid sampling each time a new cooling/heating request is initiated, the last EWT value recorded is used for the next hour. During boiler-less control heating, if the setpoint has not been achieved following the one (1) hour, a new EWT reading is recorded and the appropriate control action taken. During WSE and compressor (DX) operation, the EWT is refreshed as often as the analog input is polled.

## Sampling for Waterside Economizer Units

EWT is used to determine whether WSE operation is feasible. If the EWT meets the configured Economizer Enable Minimum Water Temperature Setpoint, WSE operation is possible. EWT sampling activates when the following conditions have been met:

- BV/9 (Water Temperature Sampling Enable) is enabled.
- EWT is not communicated through a BAS and the unit is equipped with a WSE, then following must occur:
  - A new control request for cooling, isolation valve is closed, and more than one (1) hour has passed since the last EWT sample.

When the above conditions have been met, Isolation Valve is opened for three (3) minutes, the EWT reading is recorded, and WSE operation feasibility is determined. The isolation valve remains open regardless.

### Sampling for Electric Heat Units

For units equipped with electric heat and configured for boiler-less control, EWT is used to determine whether DX heating should be disabled and electric heat enabled. EWT sampling is activated when the following conditions are met:

- BV/9 (Water Temperature Sampling Enable) is enabled.
- If the EWT is not communicated through a BAS and the unit is equipped with electric heat configured for boiler-less control is not a cooling-only unit, then following must occur:
  - There is a new control request for cooling, isolation valve is closed, and more than one (1) hour has passed since the last EWT sample; **OR**
  - The boiler-less electric heat is running and more than one (1) hour has passed since the last EWT sample.

When the above conditions have been met, Isolation Valve is opened for three (3) minutes, the EWT reading is recorded, and electric heat operation feasibility is determined. If boiler-less electric heat is enabled, the isolation valve closes, which halts water flow to the unit.

**Table 14. EWT sampling when enabled unit configurations**

EWT Sampling Enabled by Default	Unit Build Configuration
No	Heat pump (HP)
Yes	HP with WSE
Yes	HP + electric heat (boiler-less)
Yes	HP + electric heat + WSE
No	HP + electric heat (concurrent)
Yes	HP + electric heat (concurrent) + WSE
No	Cooling only
Yes	Cooling only with WSE
No	Cooling + electric heat (boiler-less)
Yes	Cooling + electric heat (boiler-less) + WSE

### Waterside Economizer Operation

The Symbio 400–B/500 controller supports the use of a 2-position waterside economizer (WSE). The WSE is only active in cooling mode and if the AV/5 Entering Water Temperature Active is lower than AV/8 Economizer Enable Minimum Water Temperature Setpoint. If the zone requires cooling and the WSE is enabled, the WSE valve opens and begins controlling the zone. If the WSE capacity cannot cool the zone, then stage-1 of the compressor cooling is allowed to operate with WSE. Stage 2 of compressor cooling is not allowed to run under any circumstances when the WSE is on. The WSE enable setpoint may need to be reduced in order to increase unit capacity. When the WSE and the compressor are running simultaneously, coil frosting may occur. The controller controls two (2) devices to prevent this from occurring.

### Coil Icing Protection

A fixed temperature device is mounted to the evaporator coil and wired to a binary input on the Symbio 400–B/500 controller. When the binary input on the controller trips (in alarm situations), the actions shown the following table occur. This low-level diagnostic automatically resets when the binary input changes to the normal state. The compressor minimum ON and OFF times (3 minutes) is enforced during this mode.

**Table 15. Coil icing**

Cooling Mode	Control Action
Economizer	None
Economizer and Stage-1 DX	Disable Stage-1 DX
Stage-1 and Stage-2 DX	Disable DX Stages 1 and 2

*Note: The fan remains ON during this operation.*

### Low Leaving Air Protection

This mode is activated during WSE operation and controlled by the discharge air sensor. If the discharge air temperature drops below the AV/21 Discharge Air Temperature Low Limit Setpoint (default 47° F) for one (1) minute, the following actions occur as shown in the following table. This low-level diagnostic automatically resets when the binary input changes to the normal state. The compressor minimum ON and OFF times (3 minutes) is enforced during this mode.

**Table 16. Low Leaving air**

Cooling Mode	Control Action
Economizer	None
Economizer and Stage-1 DX	Disable Stage-1 DX
Stage-1 and Stage-2 DX	None

*Note: The fan remains ON during this operation.*

## Electric Heat Operation

The Symbio 400–B/500 controller supports stage-1 electric heat by three methods:

- Supplemental
- Boiler-less
- Main Heat

### Supplemental

When applied, the electric heat is cycled ON as the last stage of heating. Compressor 1 and 2 (where applicable) energize and the electric heat operates concurrently with the compressors, as needed, to maintain space temperature.

### Boiler-less

When applied, the electric heat enables based on the Entering Water Temperature (EWT). Both the compressor(s) and electric heat are not allowed to operate at the same time. Boiler-less electric heat is controlled by the EWT and compressor heat disable setpoint. If the unit is in the heating mode and EWT falls below the compressor heat disable setpoint, the compressor is then disabled for heating and the electric heat cycles to maintain temperature. Boiler-less control disables if the EWT rises 5°F degrees above the compressor heat disable setpoint. The EWT value can be either local or communicated. In applications where the local water sensor is used, the unit may utilize the Entering Water Temperature Sampling function to verify water temperature.

### Main Heat

The electric heat is utilized as the only form of heat for the unit. The compressor and electric heat do not operate at the same time. When in the heating mode, the electric heat cycles to maintain space temperature.

### Compressor Cooling (DX)

The Symbio 400–B/500 controller supports two (2) stages of DX cooling. The control is proportional and based on an error rate of 3°F degrees for single compressor operation and 5°F degrees for 2-



compressor units. Zone temperature is compared against active setpoints for compressor operation. OFF, pulse width modulation (PWM), or ON are how the compressor can be controlled.

**Note:** *When the control is in the dehumidification mode, only OFF and ON are valid compressor states.*

At startup or during mode transition, if both compressors are requested to run, Compressor 1 is energized first and Compressor 2 waits until the next control cycle (10 seconds) to energize.

### Water Isolation Valves

The Symbio 400–B/500 controller supports the operation of a water isolation valve for variable speed pumping systems. The controller operates as if an isolation valve is always present. The presence or absence of an isolation valve is not a configuration factor. Under normal operation, the controller opens the isolation valve under the following conditions:

- DX Heating request.
- DX Cooling or WSE request.
- When control is in DX heat or cool mode and is controlling with pulse width modulation, the valves remain open during the pulse width modulation cycle.
- Active dehumidification request.
- EWT sampling request; valves remain open for three (3) minutes.
- Manual testing.
- During DX operation; the valves open for 20 seconds to ensure adequate water flow before energizing the compressor outputs.
- Upon opening, the valve remains open for a minimum of 10 minutes to reduce excessive valve cycling.

Isolation Valve 1 must remain open when the control is in an active cooling, heating, or active dehumidification mode. If Circuit/Compressor 1 is taken off line, Isolation Valve 1 remains open to allow operation of Circuit 2. Under normal operation, the isolation valves are closed under the following conditions:

- When the compressor and WSE are controlled OFF and the when the 10-minute minimum ON has expired.

**Note:** *If the WSE is disabled due to the economizer enable parameter, or through the BAS system and cooling demand is present, the isolation valve remains open for compressor operation.*

- Power is lost, valves de-energize to the closed position.
- Manual test OFF.

## Other Modes

### Active Dehumidification

The Symbio 400–B/500 controller controls the zone to the active cooling setpoint using proportional control. In addition, it also controls one (1) stage of DX cooling in conjunction with one (1) state of reheat. The only supported active dehumidification type during this period is hot gas reheat.

The factory-supplied Symbio 400–B/500 controller supports one (1) binary output for the control of a 2-position hot gas reheat solenoid valve. This valve is normally closed and opens when energized, providing the flow of hot refrigerant gas through the reheat coil. The reheat coil is sized to provide neutral air at 75°F loop condition with 75°F dry bulb return air at 75% relative humidity. When in the active dehumidification mode, only the first stage DX cooling is allowed to run on 2-stage units.

Active dehumidification can occur only when the controller is in the cooling mode. Active dehumidification is not allowed in heating mode. Active dehumidification can be active during all times of day schedules.

A humidity sensor is used to measure the zone relative humidity and is compared against the relative humidity enable/disable setpoints. Relative humidity level can be communicated to the controller from a BAS. The default values for active dehumidification enable is 60% relative humidity. Disable point is 52% relative humidity. These values are configured by adjusting AV/68, Space Relative Humidity Deadband.

To avoid sub-cooling the space if the reheat is not sized properly, or during certain system conditions, a low limit temperature is established to exit active dehumidification mode. The low limit is the active cooling setpoint in the Occupied and Unoccupied standby modes.

In the Unoccupied mode, the default occupied cooling setpoint is used as the low limit. This enables extended active dehumidification during unoccupied modes, which allows sub-cooling the space to the default Occupied setpoint. If the zone temperature reaches the low limit, the DX cooling and reheat are turned off. The zone temperature must rise a 0.75°F degree above the low limit before the DX cooling and reheat are allowed to operate again.

**Note:** *While in the active dehumidification mode, if there is a call for capacity by the unit the zone temperature setpoint will take priority over the relative humidity setpoints.*

Active dehumidification occurs during the following:

- Unit mode = cooling
- Relative humidity > enable setpoint

Reheat in the active dehumidification mode is utilized under the following condition:

- Zone temperature is above the active cooling setpoint.
- Zone temperature < 1.5°F degrees above the active cooling setpoint.

Compressor 2 is not on at the same time as the reheat solenoid. For both single and 2-stage cooling, the following conditions cause the Symbio 400–B/500 controller to transition out of active dehumidification mode:

- Relative humidity < Disable setpoint
- Unit Mode = Heating

### **Passive Dehumidification**

Passive dehumidification slows down the approach to zone temperature setpoint to run compressor longer and remove more moisture during the cooling cycle.

The factory-supplied Symbio 400–B/500 supports passive dehumidification on one stage or two stage, single compressor units with an ECM fan. A relative humidity sensor and discharge air temperature sensor must be installed. If hot gas reheat is present, then active dehumidification will run instead of passive dehumidification. Two compressor units do not support passive dehumidification at this time.

**Note:** *Passive dehumidification is available on Symbio 400–B/500 controllers with System Build 3.00 and newer.*

To enter passive dehumidification mode the following conditions must be met:

- Unit must be in cooling mode.
- Passive dehumidification (BV21 Passive Dehumidification Enable) must be enabled.
- Controller must be in occupied, occupied standby, or occupied bypass mode.
- A valid humidity value must be provided. This can be provided through a wired or wireless sensor input or communicated through the BAS.
- The active humidity value must be greater than the dehumidification setpoint (AV6 Space Humidity Active > AV36 Space Dehumidification Setpoint BAS).
- The active space temperature must be greater than the occupied cooling setpoint minus ½ degree (AV59 Space Temperature Active > AV28 Space Temperature Setpoint Active - 0.5°F).
- The discharge air temperature must be greater than the dehumidification discharge air temperature setpoint plus 1 degree (AI4 Discharge Air Temperature > AV39 Dehumidification Discharge Air Setpoint BAS + 1°F).
- It has been a minimum of 10 minutes since exiting the last passive dehumidification session.
- Fan must be at minimum speed or off (cycling fan).
- Water side economizing is not available.

When the unit enters passive dehumidification mode, the fan will stay at active minimum setpoint for a minimum of three minutes. At the end of the three minutes, the fan will be allowed to modulate, to max fan speed, slowly helping to remove moisture content in the air and minimizing the effect on space temperature. During passive dehumidification the compressor will run at 100% capacity. The fan will

modulate to maintain discharge air dehumidification setpoint (AV39 Dehumidification Discharge Air Setpoint BAS). When running in passive dehumidification mode “Dehumidification” will be reported by MV5 Heat Cool Mode Status.

To exit passive dehumidification mode one of the following conditions must be met:

- Unit is no longer in cooling mode.
- The active humidity value drops below the dehumidification setpoint minus the dehumidification dead band (AV6 Space Humidity Active < AV36 Space Dehumidification Setpoint BAS – AV68 Space Relative Humidity Deadband).
- The active space temperature is greater than 2 degrees above the active setpoint for 10 minutes with less than ½ degree drop in the 10 minutes. At this the control aborts passive dehumidification and applies cooling control.
- The active space temperature is 1.5 degrees below active setpoint.

### **Defrost**

For defrost operation, a sensor is wired to a binary input on the Symbio 400–B/500 controller. When a defrost condition is detected, the compressor(s) are disabled and the unit is placed in the defrost mode. During defrost, the compressor(s) are OFF and the fan continuously operates. The unit remains in the defrost mode until the sensor resets and the unit returns to normal operation after the mode is discontinued.

### **Pre-Heat**

The Symbio 400–B/500 controller keeps the 2-position outdoor air damper closed anytime during the occupied mode when the space temperature is 3°F degrees or more below the heating setpoint. The damper remains closed indefinitely during morning pre-heat until the space temperature is within 2°F degrees of the effective heating setpoint. The unit runs at full capacity until setpoint is met.

### **Pre-Cool**

The Symbio 400–B/500 controller keeps the 2-position outdoor air damper closed for up to one (1) hour at every transition from unoccupied to occupied mode when the space temperature is 3°F degrees or higher above the cooling setpoint. The damper remains closed during pre-cool until the space temperature is within 2°F degrees of the effective cooling setpoint. The unit runs at full capacity until the setpoint is met.

### **Fan Status**

There are two (2) methods to perform fan status monitoring:

- The status of the fan is reported based on the state of the binary output(s) dedicated to fan control. The Supply Fan Speed Status (AV/73) is reported as ON (100%) whenever the corresponding binary output is directed ON. The Supply Fan Speed Status is reported as OFF (0%) when the fan output is directed OFF.
- The Symbio 400–B/500 controller has an optional binary input available for a fan status device (current sensing relay) which can provide feedback of fan operation. If the device does not indicate fan operation after one (1) minute as commanded ON, a unit shut down is initiated, the unit is latched OFF, and a diagnostic is generated.

### **Filter Status and Maintenance Timer**

The unit filter status/maintenance timer is based on the cumulative run hours of the unit fan. The Symbio 400–B/500 controller compares the fan run time against an adjustable Filter Runtime Hours Setpoint (AV/12), and recommends unit maintenance as required. The Tracer TU service tool is used to edit the maintenance required setpoint time. After exceeding the setpoint limit, the controller generates a maintenance required informational diagnostic. When the setpoint time is set to zero, this feature is disabled by the controller. The Tracer TU service tool is required to clear the Maintenance Required informational diagnostic. After the diagnostic is cleared, the Symbio 400–B/500 controller resets the fan runtime to zero and begins accumulating fan run hours again. If at any time the unit loses power, the timer is reset to zero.



# Operational Troubleshooting

This section provides information about the various diagnostics and troubleshooting for the Symbio 400–B/500 controller.

**⚠ WARNING**

**Live Electrical Components!**  
 Failure to follow all electrical safety precautions when exposed to live electrical components could result in death or serious injury.  
 When it is necessary to work with live electrical components, have a qualified licensed electrician or other individual who has been properly trained in handling live electrical components perform these tasks.

## Diagnostics

**Table 17. Symbio 400–B/500 controller diagnostics**

Diagnostic	Unit Response	Latching/non-latching	Reset
High/Low Pressure Cutout/Freeze Protection	<ul style="list-style-type: none"> <li>Fan OFF</li> <li>Valves Closed</li> <li>Compressor OFF</li> </ul> <p><i>Note: In a 2-compressor unit, the unit continues to operate if a compressor is available.</i></p>	Latching	Auto-reset once every 24 hours. If safety generate a diagnostic more than once, a communicated or manual reset is required.
Low Air Flow/Fan Failure  This diagnostic is generated when a fan status device is present and fails to close after one minute of unit startup, or when it opens for more than one minute during normal unit operation.	<ul style="list-style-type: none"> <li>Fan OFF</li> <li>Valves Closed</li> <li>Compressor OFF</li> </ul>	Latching	Communicated or manual reset is required.
Space Temperature Failure <sup>(a)</sup>  If space temperature is invalid or not present, a space temperature alarm occurs.	<ul style="list-style-type: none"> <li>Fan OFF</li> <li>Valves Closed</li> <li>Compressor OFF</li> </ul>	Non-latching	Auto resets.
Entering Water Temperature Failure <sup>(a)</sup>  If the Entering Water Temperature is configured but invalid or not present, an entering water temperature alarm occurs.	<ul style="list-style-type: none"> <li>Fan Enabled</li> <li>No Boiler Control Disabled</li> <li>Waterside Economizer Enabled</li> </ul>	Non-latching	Auto resets.
Discharge Air Temperature Limit <sup>(a)</sup>  When the discharge air exceeds the low limit setpoint and the unit cannot correct it by altering capacity, a Discharge Air Temp Low Limit diagnostic is generated.	<ul style="list-style-type: none"> <li>Fan on</li> <li>Waterside Economizer enabled</li> <li>compressor disabled</li> </ul>	Non-latching	Auto-reset once every 24 hours. If safety generate a diagnostic more than once, a communicated or manual reset is required.
Humidity Input Failure <sup>(a)</sup>  If RH is configured but invalid or not present, a humidity input alarm occurs.	<ul style="list-style-type: none"> <li>Fan Enabled</li> <li>Valves Enabled</li> <li>Compressor Enabled</li> <li>Reheat Disabled</li> </ul>	Non-latching	Auto resets.
CO <sub>2</sub> Sensor Failure  If CO <sub>2</sub> is configured but invalid or not present, a CO <sub>2</sub> input alarm occurs.	<ul style="list-style-type: none"> <li>Fan Enabled</li> <li>Valves Enabled</li> <li>Compressor Enabled</li> </ul>	Non-latching	Auto resets.

**Table 17. Symbio 400–B/500 controller diagnostics (continued)**

Diagnostic	Unit Response	Latching/non-latching	Reset
<b>Filter Change Required</b>  The Filter Change Required diagnostic is generated when the fan run-time exceeds the configured limit. This diagnostic is useful for filter change notification.  <i>Note: If power to the unit is cycled or discontinued for any reason, all maintenance timers automatically reset.</i>	<ul style="list-style-type: none"> <li>• Fan Enabled</li> <li>• Valves Enabled</li> <li>• Compressor Enabled</li> </ul>	Non-latching	Communicated or manual reset is required
<b>Local Fan Mode Failure<sup>(a)</sup></b>  If the hard wired fan mode input to the Symbio 400–B/500 controller is invalid, a local fan mode alarm is generated.	<ul style="list-style-type: none"> <li>• Fan Enabled</li> <li>• Valves Enabled</li> <li>• Compressor Enabled</li> </ul>	Non-latching	Auto resets.
<b>Local Setpoint Failure</b>  If the hard wired setpoint input to the Symbio 400–B/500 controller is invalid, a local setpoint alarm is generated.	<ul style="list-style-type: none"> <li>• Fan Enabled</li> <li>• Valves Enabled</li> <li>• Compressor Enabled</li> </ul>	Non-latching	Auto resets.
<b>Defrosting Compressor Lockout:</b> The defrost stat used with the Symbio 400–B/500 controller on DX units is wired in series with the condensing unit. When it opens to indicate a frost condition, the controller senses the open circuit and then de-energizes the compressor output. A defrosting diagnostic is generated at this point.			

<sup>(a)</sup> These diagnostics are non-latching and automatically reset when the input is present and valid.

## Override Outputs

Use the Tracer TU service tool to control Multi-state value 12 (MV/12) of the Symbio 400–B/500 controller to any of the specific output test states listed in the table below. There are two (2) output test methods available:

- Overriding Manual Test Sequence (MV/12) to Control the Outputs.
  - Open Tracer TU and select the Multi-state point tab. The TGP2 program controlling the manual test states is at priority level 9. Select a higher priority level in order for the controller to allow the override. The controller automatically returns to normal operation if the override is left in place for a given state for more than one (1) hour.
- Using the Symbio 400–B/500 controller Service Pin to Step Through Manual Output Tests.
  - The manual test mode can also be initiated by pressing and holding the Symbio 400–B/500 controller service pin for two (2) seconds. After pressing the service pin, the service LED illuminates green and then turns off after the TGP2 code has advanced to the next step. At this point, either press the service pin to advance to the next step or stay in the current step for up to one (1) hour. After one (1) hour, the unit automatically returns to Normal Operation. For both manual output test options described above, the unit ignores mechanical safeties such as compressor delays and minimum on/off times. However, if a diagnostic is triggered that would typically force the compressor(s) off, the controller then allows any states that request compressor operation and will advance directly to Normal Operation.

**Table 18. Output test states**

State	Mode <sup>(a)</sup>	ECM Fan Speed	Fan Enable / High	Water Side Economizer	Fan Low	Comp 1	Comp 2	Electric Heat/Hot Gas Reheat	Electric Heat (Units With Both HGR and EH)	Reversing Valve	Isolation Valve	Outdoor Air Damper
1	Off	AO1 OFF	BO1 OFF	BO2 OFF	BO3 OFF	BO4 OFF	BO5 OFF	BO6 OFF	XM32 BO1 OFF	BO7 OFF	BO8 OFF	BO9 OFF
2	Isolation Valve Open	OFF	OFF	OFF	OFF	OFF	OFF	OFF	OFF	OFF	ON	OFF
3	Fan Low	MIN	ON	OFF	ON	OFF	OFF	OFF	OFF	OFF	ON	OFF
4	Fan High	MAX	ON	OFF	OFF	OFF	OFF	OFF	OFF	OFF	ON	OFF
5	Water Side Economizer	MAX	ON	ON	OFF	OFF	OFF	OFF	OFF	OFF	ON	OFF
6	Compressor Cool Stage 1	MAX	ON	OFF	OFF	ON	OFF	OFF	OFF	ON	ON	OFF
7	Compressor Cool Stage 2	MAX	ON	OFF	OFF	ON	ON	OFF	OFF	ON	ON	OFF
8	Hot Gas Reheat	MAX	ON	OFF	OFF	ON	OFF	ON	OFF	ON	ON	OFF
	Units Without Hot Gas Reheat	MAX	ON	OFF	OFF	OFF	OFF	OFF	OFF	ON	ON	OFF
9	Elec Heat Only (Boilerless)	MAX	ON	OFF	OFF	OFF	OFF	ON	OFF	OFF	ON	OFF
	Concurrent (DX Heat + Elec Heat)	MAX	ON	OFF	OFF	ON	ON	ON	OFF	OFF	ON	OFF
	Elec Heat Only (Boilerless) Units Equipped With Both HGR and EH	MAX	ON	OFF	OFF	ON	OFF	OFF	OFF	OFF	ON	OFF
10	Concurrent (DX Heat + Elec Heat) Units Equipped With Both HGR and EH	MAX	ON	OFF	OFF	ON	ON	OFF	ON	OFF	ON	OFF
	Units Without Elec Heat	MAX	ON	OFF	OFF	OFF	OFF	OFF	OFF	OFF	ON	OFF
11	Compressor Heat Stage 1	MAX	ON	OFF	OFF	OFF	OFF	OFF	OFF	OFF	ON	OFF
12	Compressor Heat Stage 2	MAX	ON	OFF	OFF	ON	ON	OFF	OFF	OFF	ON	OFF
13	Outside Air Damper	MAX	ON	OFF	OFF	OFF	OFF	OFF	OFF	OFF	OFF	ON
<b>Turn All Outputs OFF, Then Release to Normal Control Immediately</b>												
13	Normal Operation	MAX	ON	OFF	OFF	OFF	OFF	OFF	OFF	OFF	OFF	ON

<sup>(a)</sup> A 60 minute time limit will be imposed on each Mode step. Once the timer expires, the unit will transition back to normal control. If the unit is actively operating when a Test Mode is requested, the unit will follow all startup and shutdown requirements to energize/de-energize the compressor and supply fan outputs. If an optional output is not present then the current step is the same as the prior step unless otherwise stated in the table.

## Resetting Diagnostics

The following methods describe resetting unit diagnostics:

- High/Low Pressure Cutout
- Manual Output Test
- Cycling Power
- Building Automation System (BAS)
- Tracer TU Service Tool
- Cycling the Fan Switch

### High/Low Pressure Cutout

The Symbio 400–B/500 controller includes a one-time automatic diagnostic reset function. This function automatically recovers a unit when the High/Low Pressure Cutout diagnostic occurs. When this diagnostic occurs, the controller responds as defined in “Diagnostics,” p. 52. After the controller detects the High/Low Pressure Cutout diagnostic, it waits 30 minutes before invoking the automatic diagnostic reset function. The automatic diagnostic reset function clears the High/Low Pressure Cutout diagnostic and attempts to restore the unit to normal operation. The controller resumes normal operation until another diagnostic occurs. If a High/Low Pressure Cutout diagnostic reoccurs within 24 hours after an automatic diagnostic reset, the diagnostic requires a manual reset.

### Manual Output Test

The service button on the Symbio 400–B/500 controller can be used during installation to verify proper end device operation, or during troubleshooting. When the service button is pressed, the controller exercises all outputs in a predefined sequence. The first and last steps of the sequence reset the controller diagnostics.

### Cycling Power

When turning off the 24 Vac power to the Symbio 400–B/500 controller and then powering on again, the unit cycles through a power-up sequence and clears all timers. By default, the controller attempts to reset all diagnostics at power-up. Diagnostics presented at power-up, and those that occur after power-up, are handled according to the defined unit diagnostics sequences.

### Building Automation System (BAS)

Some building automation systems can reset diagnostics in the Tracer unit controller.

### Tracer TU Service Tool

The Tracer TU service tool can be used to reset diagnostics in the Symbio 400–B/500 controller (from the Alarms tab).

### Cycling the Fan Switch

If the user cycles the fan speed switch from off to ON or AUTO, the Symbio 400–B/500 controller resets all diagnostics. Diagnostics may immediately recur if the problem still exists.



# Operational Causes and Diagnostics

**Table 19. Symbio 400–B/500 controller diagnostic causes and diagnostics**

Probable Cause	Diagnostic
<b>Fan Not Energizing</b>	
Unit Wiring	The wiring between the Symbio 400–B/500 controller outputs, fan relays, and contacts must be present and correct for normal fan operation.
Failed End Device	The fan motor and relay must be checked to ensure proper operation.
Normal Operation	<p>The fan turns OFF when:</p> <ul style="list-style-type: none"> <li>• The Symbio 400–B/500 controller receives a communicated off signal.</li> <li>• The fan-speed switch is set to OFF if no communicated value is present.</li> <li>• Specific diagnostics are generated.</li> <li>• The default fan speed is set to OFF and the fan is operating in the Auto mode.</li> </ul> <p>If the Symbio 400–B/500 controller is in unoccupied mode, the fan cycles between OFF and the highest fan speed.</p>
No power to the Controller	If the Symbio 400–B/500 controller does not have power, the unit fan does not operate. For the unit to operate normally, it must have an input voltage of 24 Vac. If the Marquee/Power LED is OFF continuously, the controller does not have sufficient power or has failed.
Diagnostic Present	Several diagnostics affect fan operation.
Unit Configuration	The Symbio 400–B/500 controller must be properly configured based on the actual installed end devices and application. If the unit configuration does not match the actual end device, the fans may not work correctly.
Random Start Observed	After power-up, the Symbio 400–B/500 controller always observes a random start from 5 to 30 seconds. The unit remains OFF until the random start time expires.
Cycling Fan Operation/ Continuous	The Symbio 400–B/500 controller continuously operates the fan when in the occupied, occupied standby, or occupied bypass mode. When the controller is in the unoccupied mode, the fan is cycled between high speed and OFF with capacity.
Unoccupied Operation	Even if the Symbio 400–B/500 controller is configured for continuous fan operation, the fan normally cycles with capacity during unoccupied mode. While unoccupied, the fan cycles ON or OFF with heating/cooling to provide varying amounts of heating or cooling to the space.
Fan Mode Off	If a local fan mode switch determines the fan operation, the OFF position controls the fan to off.
Requested Mode Off	The user can communicate a desired operating mode (such as OFF, heat, and cool) to the controller. If OFF is communicated to the Symbio 400–B/500 controller, it controls the fan to off. There is no heating or cooling.
<b>Isolation Valves Remain Closed</b>	
Unit Wiring	The wiring between the Symbio 400–B/500 controller outputs and the valve(s) must be present and correct for normal valve operation. Refer to applicable wiring diagram.
Failed End Device	The valves must be checked to ensure proper operation.
No power to the Controller	If the Symbio 400–B/500 controller does not have power, the unit valve(s) will not operate. For the controller to operate normally, apply an input voltage of 24 Vac. If the Marquee/Power LED is OFF continuously, the unit does not have sufficient power or has failed.
Diagnostic Present	Several diagnostics affect valve operation. For detailed information about these diagnostics, refer to Table 13, p. 46.
Normal Operation	The Symbio 400–B/500 controller opens and closes the valves to meet the unit capacity requirements.
Unit Configuration	The Symbio 400–B/500 controller must be properly configured based on the actual installed end devices and application. If the unit configuration does not match the actual end device, the valves may not work correctly.
Random Start Observed	After power-up, the Symbio 400–B/500 controller always observes a random start from 5 to 30 seconds. The controller remains OFF until the random start time expires.
Requested Mode Off	The user can communicate a desired operating mode (such as OFF, heat, and cool) to the Symbio 400–B/500 controller. If OFF is communicated to the unit, the controller controls the fan to off. There is no heating or cooling.
Entering Water Temperature Sampling Logic	The Symbio 400–B/500 controller includes entering water temperature sampling logic. It is used to ensure that the loop water is within appropriate operating temperatures for compressor heating/cooling or valid for waterside economizing. When communicating a Source Water Temperature from a BAS, ensure that there is a valid Entering Water Temperature Active. If it is known that sampling is not required, toggling the Entering Water Sampling Enable BV to disabled can be performed.



**Table 19. Symbio 400–B/500 controller diagnostic causes and diagnostics (continued)**

Probable Cause	Diagnostic
Valve Configuration	Ensure the valves are correctly configured, using the Tracer TU service tool, as normally open (NO) or normally closed (NC) as dictated by the application.
<b>Isolation Valves Remain Open</b>	
Unit wiring	The wiring between the Symbio 400–B/500 controller outputs and the valve(s) must be present and correct for normal valve operation. Refer to applicable wiring diagram.
Failed End Device	The valves must be checked to ensure proper operations.
Normal Operation	The Symbio 400–B/500 controller opens and closes the valves to meet the unit capacity requirements.
Diagnostic Present	Several diagnostics affect valve operation.
Unit Configuration	The Symbio 400–B/500 controller must be properly configured based on the actual installed end devices and application. If the unit configuration does not match the actual end device, the valves may not work correctly.
Entering Water Temperature Sampling Logic	The Symbio 400–B/500 controller includes entering water temperature sampling logic. It is automatically initiated during 2-pipe and 4-pipe changeover if the entering water temperature is either too cool or too hot for the desired heating or cooling.
Valve Configuration	Ensure the valves are correctly configured, using the Tracer TU service tool, as normally open (NO) or normally closed (NC) as dictated by the application.
<b>DX or Electric Heat Outputs Do Not Energize</b>	
Unit Wiring	The wiring between the Symbio 400–B/500 controller outputs and the end devices must be present and correct for normal operation.
Failed End Device	Check the Symbio 400–B/500 controller contactors or the electric heat element, including any auxiliary safety interlocks, to ensure proper operation.
No Power to the Controller	If the Symbio 400–B/500 controller does not have power, heat outputs do not operate. For the controller to operate normally, apply an input voltage of 24 Vac. If the Marquee/Power LED is OFF continuously, the controller does not have sufficient power or has failed.
Diagnostic Present	Several diagnostics affect DX and electric heat operation.
Normal Operation	The Symbio 400–B/500 controller controls compressor or electric heat outputs as needed to meet the unit capacity requirements.
Unit Configuration	The Symbio 400–B/500 controller must be properly configured based on the actual installed end devices and application. If the controller configuration does not match the actual end device, DX or electric heat may not operate correctly.
Requested Mode Off	The user can communicate a desired operating mode (such as OFF, heat, and cool) to the Symbio 400–B/500 controller. If OFF is communicated to the unit, the controller shuts off the compressor or electric heat.
Freeze Avoidance	When the fan is OFF with no demand for capacity (0%), and the outdoor air temperature is below the freeze avoidance setpoint, the Symbio 400–B/500 controller disables compressors and electric heat outputs (100%) to prevent coil freezing. This includes unoccupied mode when there is no call for capacity or any other time the fan is OFF.
<b>Outdoor Air Damper Remains Closed</b>	
Unit Wiring	The wiring between the Symbio 400–B/500 controller outputs and the outdoor air damper must be present and correct for normal outdoor air damper operation. Refer to applicable wiring diagram.
Failed End Device	Check damper actuator to ensure proper operation.
No Power to the Controller	If the Symbio 400–B/500 controller does not have power, the outdoor air damper does not operate. For the controller to operate normally, apply an input voltage of 24 Vac. If the Marquee/Power LED is OFF continuously, the controller does not have sufficient power or has failed.
Diagnostic Present	Several diagnostics affect outdoor air damper operation.
Normal Operation	The Symbio 400–B/500 controller opens and closes the outdoor air damper based on the controller's occupancy mode and fan status. Normally, the outdoor air damper is open during occupied mode when the fan is running and closed during unoccupied mode.
Unit Configuration	The Symbio 400–B/500 controller must be properly configured based on the actual installed end devices and application. If the unit configuration does not match the actual end device, the outdoor air damper may not work correctly.
Warm-up and Cool-down Sequence	The Symbio 400–B/500 controller includes both a morning warm-up and cool-down sequence to keep the outdoor air damper closed during the transition from unoccupied to occupied. This is an attempt to bring the space under control as quickly as possible.



## Operational Causes and Diagnostics

**Table 19. Symbio 400–B/500 controller diagnostic causes and diagnostics (continued)**

Probable Cause	Diagnostic
Requested Mode Off	The user can communicate a desired operating mode (such as OFF, heat, or cool) to the Symbio 400–B/500 controller. If OFF is communicated to the unit, the unit closes the outdoor air damper.
<b>Outdoor Air Damper Remains Open</b>	
Unit Wiring	The wiring between the Symbio 400–B/500 controller outputs and the outdoor air damper must be present and correct for normal outdoor air damper operation. Refer to applicable wiring diagram.
Failed End Device	Check damper actuator to ensure proper operation.
Normal Operation	The Symbio 400–B/500 controller opens and closes the outdoor air damper based on the controller occupancy mode and fan status. Normally, the outdoor air damper is open during occupied mode when the fan is running and closed during unoccupied mode.
Unit Configuration	The Symbio 400–B/500 controller must be properly configured based on the actual installed end devices and application. If the unit configuration does not match the actual end device, the outdoor air damper may not work correctly.
<b>Erratic Air Flow / Fan Control</b>	
Unit Configuration	If unit is configured with a Constant Torque Motor when it should be configured with a Constant CFM motor. The unit may never produce designed air flow at 100% heating or cooling demand. If unit is configured with a Constant CFM Motor when it should be configured with a Constant Torque motor. The motor may never start at minimum speeds, and at maximum speeds it will be delivering excessive air flow.



# Configuration and Maintenance

This section outlines the tasks to configure and maintain the Symbio 400–B/500 controller using the Tracer TU service tool.

**Note:** *The Symbio 400–B/500 Controller is a self-serviceable unit and is not intended to be disassembled for maintenance.*

1. **Load Application Code on a Blank Symbio 400–B/500:** all field programmable Symbio 400–B/500 controllers ship without application code (firmware). Before configuring the controller, check for the unit application code using the Tracer TU service tool, as follows:
  - a. Start the Tracer TU service tool to establish a connection with the Symbio 400–B/500 controller. If no firmware is present, the following message displays: *This Symbio 400–B/500 Controller has no application code loaded. Please launch File Transfer wizard and load an appropriate configuration.*
  - b. Click **OK**. To load or upgrade the firmware, follow the procedure in the TU Online Help, *Upgrading Controller Firmware* under the book, *Managing Configurations, Firmware, and Programs*.
2. **Choose a Symbio 400–B/500 Configuration Option:**
  - a. First, get an overview of the parts of a Symbio 400–B/500 Controller configuration. Refer to TU Online Help, *The Main Parts of Device Setup and Configuration* under the book, *An Overview of Device Setup and Configuration* book in the *Tracer TU Help for Programmable Controllers*.
  - b. Carefully read the topic, *Point Configuration Overview* under the book, *Configuring and Managing Points*, for an explanation of available configuration options.

There are two main configuration options:

    - Use the Tracer TU Configuration Screen to create a factory configuration.

**Note:** *Some modifications can be made to the Trane factory water source heat pump configuration.*
    - Create or edit a custom (field programmed) configuration.
3. **Specify Controller Settings:**
  - a. Configure units of measure.
  - b. Specify the unit date and time
  - c. Specify the baud rate, if other than the default (76800).
4. **Set Up and Discover XM30/XM32/XM70/XM90 Expansion Modules:**
  - a. Mount, wire, address, and power the expansion module as described in the Installation Instructions that accompany the unit
  - b. Click the **Discover** button in the Expansion Modules box on the Controller Settings screen.

**Note:** *When adding an expansion module on the Controller Settings page, but the module is not connected to the controller, then discover it on the Controller Status screen after it is connected and powered.*

Refer to the topic, *Setting Up And Discovering Expansion Modules* under the book, *Modifying Controller Settings*, for the procedural information.
5. **Specifying an Equipment Configuration:** go to the information sources supporting the chosen configuration option.
  - a. **Option 1:** use the Tracer TU Configuration Screen to Create a Factory Configuration. Refer to the topics under the *Water Source Heat Pumps (WSHPs)* sub-books about *Configuring and Commissioning Equipment*.
  - b. **Option 2:** create a Custom Configuration. This option requires a thorough knowledge of the devices and the network to be installed, including an understanding of the TGP2 programs and the points they use. Complete the following steps:
    - Create points or open a previously created points file, make any edits, and save them to the Symbio 400–B/500 controller. When configuring points for the unit, it is important to note that

points are not pre-configured on the controller board. Instead, the board has a certain amount of memory set aside to create a point. The maximum number of points are listed in the following table.

**Table 20. Max number of points**

Type	Number
Analog Input	500 software points (either online or offline)
Analog Output	500 software points (either online or offline)
Analog Value	500 software points (either online or offline)
Binary Input	500 software points (either online or offline)
Binary Output	500 software points (either online or offline)
Binary Value	500 software points (either online or offline)
Multistate Input	500 software points (either online or offline)
Multistate Output	500 software points (either online or offline)
Multistate Value	500 software points (either online or offline)

**Note:** Create, edit, and load points, either in Tracer TU, or in the TGP2 Editor.

- Specify setpoint values and equipment parameters on the Setpoints and Setup Parameters screens (Equipment Utility).
6. **Commissioning the Hard-Wired Points:** after all points are configured, saved, and downloaded to the Symbio 400–B/500 controller, commission or test them by overriding Output and Value points. Refer to the topics under the book, *Overriding, Comparing, and Changing the Service Status of Points* .
    - **Out of Service:**
      - **Inputs/Outputs:** The out of service mode disconnects the point from its reference. With inputs, the point no longer gets the value from its reference, but allows the capability of writing to an input. With outputs, the point no longer pushes its value to its reference. In addition, the value of the point can be changed without affecting the value of reference. However, this still requires the use of the priority table.
      - **Values:** value objects will not accept a written value from on-box applications, such as TGP2 or an area when out of service. An off-box application, such as Tracer TU or Tracer SC+, allows the capability of writing to a value object. However, this still requires the use of the priority table. Existing points can be placed in or out of service by clicking the **Control** icon corresponding to the point on the Analog, Binary, or Multi-state tab screens on Status Utility.
 

**Note:** The priority number must be lower than what the point is currently controlled at in order for the override to be applied. Verify that the device ID and baud rate are correct after restoring a controller using a backup file that was created with a different controller.
  7. **Adding Side TGP2 Programs, As Needed:** after completing the hardware points and testing, create or edit TGP2 programs that will run the equipment according to the specified sequence of operations for the job. (Refer to the topics under the *Developing and Managing TGP2 Programs* TOC book in the Tracer Graphical Programming (TGP2) Editor Help for programming procedures. Also refer to the TGP2 Block Reference TOC book to learn how the various blocks work and for information about their properties.
  8. **Monitoring and Viewing Point, Alarm, and Controller Status:** refer to the topics under the book, *Viewing the Status of Points and Alarms* .
  9. **Backing Up and Restoring Files and Configurations:** upload, backup, replace, or update configuration files, controller firmware, and TGP2 programs using the File Transfer Utility and the Backup Utility. Refer to the topics under book, *Managing Configurations, Firmware, and Files* .



## Additional Resources

- *Air-Fi Wireless System IOM* (BAS-SVX40\*-EN)
- *Air-Fi Network Design* (BAS-SVX55\*-EN)
- *Air Systems for the Tracer SC+ Application Guide* (BAS-APG036\*-EN)
- *BACnet/IP Wiring and Best Practices Application Guide* (BAS-APG046\*-EN)
- *BACnet MS-TP Wiring and Link Performance Best Practices and Troubleshooting Guide* (BAS-SVX51\*-EN)
- *Symbio 400–B/500 Programmable Controller Installation, Operation, and Maintenance Guide* (BAS-SVX090\*-EN)
- Tracer Graphical Programming 2 (TGP2) Editor Online Help
- *Tracer Graphical Programming (TGP2) Application Guide* (BAS-APG008\*-EN)
- Tracer TU Online Help
- *Tracer TU Service Tool Getting Started Guide* (TTU-SVN01\*-EN)
- *VariTrane Product Catalog Parallel and Series Fan-Powered* (VAV-PRC012\*-EN)



**Notes**

---



Trane - by Trane Technologies (NYSE: TT), a global innovator - creates comfortable, energy efficient indoor environments for commercial and residential applications. For more information, please visit [trane.com](http://trane.com) or [tranetechnologies.com](http://tranetechnologies.com).

Trane has a policy of continuous product and product data improvements and reserves the right to change design and specifications without notice. We are committed to using environmentally conscious print practices.

BAS-SVX092B-EN 08 Apr 2023  
Supersedes BAS-SVX092A-EN (October 2022)

©2023 Trane