

# Service and Diagnostic Support Manual

# **ReliaTel™ Microprocessor**

# **Controls**

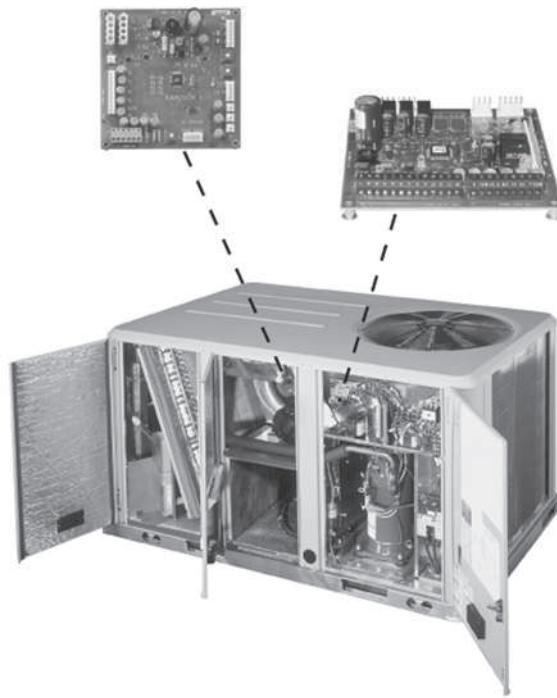

## **⚠ SAFETY WARNING**

Only qualified personnel should install and service the equipment. The installation, starting up, and servicing of heating, ventilating, and air-conditioning equipment can be hazardous and requires specific knowledge and training. Improperly installed, adjusted or altered equipment by an unqualified person could result in death or serious injury. When working on the equipment, observe all precautions in the literature and on the tags, stickers, and labels that are attached to the equipment.

# Introduction

This publication covers both electromechanical and ReliaTel™ controls. Due to the more complex application and service opportunities, greater emphasis is placed on units with ReliaTel™ controls.

This publication provides both current and historical information. Always refer to the ordering system for the latest models and associated control information.

This publication does not cover all aspects of service. It assumes the service person is an experienced commercial service technician with a strong background in electrical controls and DC circuits. If you are not experienced and fully qualified in HVAC service, do not attempt to use this manual to service equipment.

Read this manual thoroughly before operating or servicing this unit.

## Warnings, Cautions, and Notices

Safety advisories appear throughout this manual as required. Your personal safety and the proper operation of this machine depend upon the strict observance of these precautions.

---

The three types of advisories are defined as follows:



Indicates a potentially hazardous situation which, if not avoided, could result in death or serious injury.



Indicates a potentially hazardous situation which, if not avoided, could result in minor or moderate injury. It could also be used to alert against unsafe practices.



Indicates a situation that could result in equipment or property-damage only accidents.

---

## Important Environmental Concerns

Scientific research has shown that certain man-made chemicals can affect the earth's naturally occurring stratospheric ozone layer when released to the atmosphere. In particular, several of the identified chemicals that may affect the ozone layer are refrigerants that contain Chlorine, Fluorine and Carbon (CFCs) and those containing Hydrogen, Chlorine, Fluorine and Carbon (HCFCs). Not all refrigerants containing these compounds have the same potential impact to the environment. Trane advocates the responsible handling of all refrigerants-including industry replacements for CFCs and HCFCs such as saturated or unsaturated HFCs and HCFCs.

## Important Responsible Refrigerant Practices

Trane believes that responsible refrigerant practices are important to the environment, our customers, and the air conditioning industry. All technicians who handle refrigerants must be certified according to local rules. For the USA, the Federal Clean Air Act (Section 608) sets forth

the requirements for handling, reclaiming, recovering and recycling of certain refrigerants and the equipment that is used in these service procedures. In addition, some states or municipalities may have additional requirements that must also be adhered to for responsible management of refrigerants. Know the applicable laws and follow them.

### **WARNING**

#### **Proper Field Wiring and Grounding Required!**

**Failure to follow code could result in death or serious injury.**

**All field wiring MUST be performed by qualified personnel. Improperly installed and grounded field wiring poses FIRE and ELECTROCUTION hazards. To avoid these hazards, you MUST follow requirements for field wiring installation and grounding as described in NEC and your local/state/national electrical codes.**

**⚠ WARNING****Personal Protective Equipment (PPE) Required!**

Failure to wear proper PPE for the job being undertaken could result in death or serious injury.

Technicians, in order to protect themselves from potential electrical, mechanical, and chemical hazards, **MUST** follow precautions in this manual and on the tags, stickers, and labels, as well as the instructions below:

- Before installing/servicing this unit, technicians **MUST** put on all PPE required for the work being undertaken (Examples; cut resistant gloves/sleeves, butyl gloves, safety glasses, hard hat/bump cap, fall protection, electrical PPE and arc flash clothing). **ALWAYS** refer to appropriate Safety Data Sheets (SDS) and OSHA guidelines for proper PPE.
- When working with or around hazardous chemicals, **ALWAYS** refer to the appropriate SDS and OSHA/GHS (Global Harmonized System of Classification and Labelling of Chemicals) guidelines for information on allowable personal exposure levels, proper respiratory protection and handling instructions.
- If there is a risk of energized electrical contact, arc, or flash, technicians **MUST** put on all PPE in accordance with OSHA, NFPA 70E, or other country-specific requirements for arc flash protection, **PRIOR** to servicing the unit. **NEVER PERFORM ANY SWITCHING, DISCONNECTING, OR VOLTAGE TESTING WITHOUT PROPER ELECTRICAL PPE AND ARC FLASH CLOTHING. ENSURE ELECTRICAL METERS AND EQUIPMENT ARE PROPERLY RATED FOR INTENDED VOLTAGE.**

**⚠ WARNING****Follow EHS Policies!**

Failure to follow instructions below could result in death or serious injury.

- All Trane personnel must follow the company's Environmental, Health and Safety (EHS) policies when performing work such as hot work, electrical, fall protection, lockout/tagout, refrigerant handling, etc. Where local regulations are more stringent than these policies, those regulations supersede these policies.
- Non-Trane personnel should always follow local regulations.

**Copyright**

This document and the information in it are the property of Trane, and may not be used or reproduced in whole or in part without written permission. Trane reserves the right to revise this publication at any time, and to make changes to its content without obligation to notify any person of such revision or change.

**Trademarks**

All trademarks referenced in this document are the trademarks of their respective owners.

**Revision History**

- Updated General Information chapter.
- Updated Low Voltage Terminal Boards chapter.
- Updated Typical Control Box Layout chapter.
- Updated ReliaTel™ RTRM, RTOM, RTVM, RTAM and RTDM chapters.
- Updated ReliaTel™ Temporary Operation, LED Functions, Test Mode, Hot Surface Ignition Control, and Ventilation Override chapters.
- Updated Single Zone VAV chapter.
- Updated Verifying Proper Airflow chapter.
- Updated Thermostats and Sensors chapter.
- Updated Operation with a Conventional Thermostat (Constant Volume) chapter.
- Updated Zone Sensor Module Testing chapter.
- Updated RTRM/RTOM/RTDM - Temperature Inputs chapter.
- Updated Zone Sensor Averaging chapter.
- Updated COMM3/4 Interface chapter.
- Updated Direct Spark Ignition Control chapter.
- Updated ReliaTel™ Hot Surface Ignition Control chapter.
- Updated Heat Pump chapter.
- Updated Economizer chapter.
- Updated Electromechanical Units chapter.
- Updated ReliaTel™ - Supply Air Tempering Control chapter.
- Updated ReliaTel™ Ventilation Override chapter.
- Updated Demand Control Ventilation (DCV) chapter.
- Updated Dehumidification chapter.
- Updated Low Ambient Mechanical Cooling Operation (3 to 25 Ton Units) chapter.
- Updated Constant Volume (CV) and Variable Air Volume (VAV) chapter.
- Updated Outdoor Airflow Compensation for MZVAV Units chapter.

# Table of Contents

|                                       |    |   |    |
|---------------------------------------|----|---|----|
| General Information .....             | 10 | Compressor Will Not Run - No              |    |
| ReliaTel™ .....                       | 10 | Diagnostics .....                         | 37 |
| Precedent™ 3 to 10 Tons and           |    | System OFF - No Diagnostic .....          | 37 |
| Voyager™ 12.5 to 50 Tons Dedicated    |    | Heat Pump - Compressors Will Not          |    |
| Packaged Rooftops .....               | 10 | Run .....                                 | 37 |
| Odyssey™ .....                        | 10 | MZVAV/VAV unit - Additional               |    |
| ReliaTel™ vs. Electromechanical ..... | 10 | Diagnostics .....                         | 37 |
| ReliaTel™ Refrigeration Module        |    | 27.5 to 50 Tons - Additional              |    |
| (RTRM) .....                          | 10 | Diagnostics .....                         | 37 |
| ReliaTel™ Air Handler Module          |    | BACnet® Operations .....                  | 38 |
| (RTAM) .....                          | 10 | Default Operations .....                  | 38 |
| ReliaTel™ Option Module (RTOM) .....  | 10 | Tracer® TD-5 Display for ReliaTel™        |    |
| ReliaTel™ Ventilation Module (RTVM)   |    | Controller .....                          | 39 |
| — 27.5 to 50 Tons Units .....         | 11 | ReliaTel™ Temporary Operation .....       | 40 |
| ReliaTel™ Ventilation Module (RTVM)   |    | 3 to 25 Tons .....                        | 40 |
| — 3 to 25 Tons Units .....            | 11 | MZVAV .....                               | 40 |
| ReliaTel™ Dehumidification Module     |    | Temporary Sensor (Thermistor)             |    |
| (RTDM) .....                          | 11 | Attached to J6-1 and J6-2 Only .....      | 40 |
| Economizer Actuator with Module (ECA  |    | ReliaTel™ Option Module (RTOM) .....      | 41 |
| or RTEM) .....                        | 11 | RTOM Location .....                       | 42 |
| ReliaTel™ Electromechanical           |    | 3 to 10 Tons .....                        | 42 |
| Economizer Module (RTEM-EM) .....     | 11 | 12.5 to 50 Tons .....                     | 42 |
| Variable Speed Module (VSM) .....     | 11 | RTOM Inputs .....                         | 42 |
| COMM3/4 Communication                 |    | J1, J2 Inputs .....                       | 42 |
| Interface .....                       | 11 | J3 Inputs .....                           | 42 |
| LonTalk® Communication                |    | J4 Output .....                           | 42 |
| Interface .....                       | 12 | J4 Input .....                            | 42 |
| ReliaTel™ BACnet® Communication       |    | J5 Output .....                           | 42 |
| Interface (BCI-R) .....               | 12 | J6 Inputs .....                           | 42 |
| Module Flow Diagram .....             | 13 | J7 Inputs .....                           | 42 |
| Low Voltage Terminal Boards .....     | 25 | J8 Input .....                            | 42 |
| LVTB – 01 (Part # BLK00940) .....     | 25 | J9 Input .....                            | 43 |
| LVTB – 02 (Part # TER00116) .....     | 25 | J10 Input .....                           | 43 |
| LVTB – 03 (Part # TER01406) .....     | 25 | J11 Output .....                          | 43 |
| LVTB – 04 (Part # BLK01455) .....     | 26 | J12 Input .....                           | 43 |
| Typical Control Box Layout .....      | 27 | Setpoint Potentiometers .....             | 43 |
| ReliaTel™ Refrigeration Module        |    | Discharge Air (DA) Cooling - Setpoint     |    |
| (RTRM) .....                          | 33 | Lower Limit .....                         | 44 |
| RTRM Diagnostics .....                | 34 | Voyager™ Light Commercial .....           | 44 |
| RTRM System LED Diagnostic            |    | Precedent™ .....                          | 45 |
| Indicator .....                       | 34 | Odyssey™ .....                            | 45 |
| Service - RTRM-J6-10 .....            | 35 | ReliaTel™ Ventilation Module (RTVM) ..... | 47 |
| System- RTRM-J6-9 .....               | 35 | RTVM Location - 3 to 25 Tons .....        | 47 |
| Cooling-RTRM-J6-8 .....               | 36 | RTVM Location - 27.5 to 50 Tons .....     | 47 |
| Heating-RTRM-J6-7 .....               | 36 | Light Commercial RTVM Inputs .....        | 48 |
| HEAT FAIL and COOL FAIL at the        |    | J1, J2 Inputs .....                       | 48 |
| Same Time, RTRM-J6-7 and 8 Pulsing    |    | RTVM Inputs .....                         | 48 |
| Voltage .....                         | 37 | J1, J2 Inputs .....                       | 48 |
| HEAT + COOL + SERVICE .....           | 37 | J3 Inputs .....                           | 48 |



|   |    |   |    |
|---|----|---|----|
| J4 Inputs . . . . .   | 48 | Indoor Fan Control Description;<br>Precedent™ 17 SEER (17 Plus) - Unit<br>Identification . . . . .  | 54 |
| J5 Output . . . . .   | 48 | Indoor Fan Control Description;<br>Backwards Curved (BC) Plenum Fan<br>Control - Unit Identification . . . . .                              | 56 |
| J11 Output . . . . .  | 48 | Indoor Fan Control Description;<br>Voyager™ Multi Speed and SZVAV<br>VFD Controlled Evaporator Fan Motor -<br>Unit Identification . . . . . | 57 |
| Setpoint Potentiometers . . . . .   | 48 | Indoor Fan Control Description;<br>Odyssey™ Multi-Speed and SZVAV<br>VFD Controlled Evaporator Fan Motor -<br>Unit Identification . . . . . | 58 |
| Pressure Transducer – Statitrac . . . . .   | 49 | SZVAV, Multi-Speed, DHC, WHC and 17<br>Plus Unit Outdoor Air Compensation and<br>Economizer Minimum Position. . . . .                       | 60 |
| ReliaTel™ Air Module (RTAM) . . . . .   | 50 | Condensate Drain Pan Overflow<br>Switch . . . . .   | 61 |
| RTAM Inputs/Outputs . . . . .   | 50 | Fresh Air Measurement and Control<br>(TraQ™) . . . . .  | 62 |
| J1 Input . . . . .  | 50 | Sequence for Setting Calibration . . . . .  | 62 |
| J2, J3 MBUS . . . . .   | 50 | Economizer Fault Detection and<br>Diagnostics . . . . .   | 64 |
| J4 Output . . . . .   | 50 | Mixed Air Temperature Low Limit<br>Diagnostic . . . . .   | 65 |
| J5 Input . . . . .  | 51 | BACnet® Communications Interface<br>(BCI) . . . . .   | 65 |
| J7 Input . . . . .  | 51 | LonTalk® Communications Interface<br>(LCI) . . . . .  | 65 |
| TB – 1, TB – 2 Output . . . . .   | 51 | Failure and Overriding Conditions . . . . .   | 65 |
| Potentiometer R13 Input Static<br>Pressure Setpoint . . . . .                               | 51 | Multi-Speed Indoor Fan . . . . .  | 65 |
| Potentiometer R22 Input Reset<br>Setpoint . . . . .   | 51 | Two-Speed Fan Control . . . . .   | 65 |
| Potentiometer R27 Input Static<br>Pressure Deadband . . . . .                               | 51 | Multi-Speed PWM Controlled Indoor<br>Fan with Dual Capacity<br>Compressor . . . . .   | 66 |
| Potentiometer R31 Input Morning<br>Warm-Up Setpoint . . . . .                               | 51 | Single Zone VAV . . . . .   | 69 |
| Potentiometer R38 Input Reset<br>Amount . . . . .   | 51 | Supply Fan Output Control - VFD<br>Equipped Units . . . . .   | 69 |
| Potentiometer R47 Input Supply Air<br>Cooling Setpoint . . . . .                            | 51 | Direct Drive Backwards Curve Plenum<br>Fan Equipped Units . . . . .   | 69 |
| Potentiometer R59 Input Supply Air<br>Heating Setpoint . . . . .                            | 51 | PWM Controlled Motor Equipped<br>Units . . . . .  | 69 |
| ReliaTel™ Dehumidification Module<br>(RTDM) . . . . .                                       | 52 | Supply Fan Mode Operation . . . . .   | 70 |
| RTDM Layout - 27.5 to 50 tons . . . . .   | 52 | Ventilation Control . . . . .   | 70 |
| RTDM Inputs/Outputs . . . . .   | 52 | Demand Controlled Ventilation . . . . .   | 70 |
| J4, J2 Inputs . . . . .   | 52 | Outside Air Damper Minimum Positions<br>without DCV . . . . .   | 70 |
| J6 Inputs . . . . .   | 52 | Dynamic Exhaust Enable Setpoint . . . . .   | 70 |
| J8 Inputs . . . . .   | 52 | Discharge Air Setpoint . . . . .  | 70 |
| J1 Output . . . . .   | 52 | Economizer Cooling . . . . .  | 70 |
| J3 Output . . . . .   | 52 | Compressor (DX) Cooling . . . . .   | 71 |
| J5 Output . . . . .   | 52 |   |    |
| ReliaTel™ Variable Speed Module<br>(VSM) . . . . .  | 53 |   |    |
| Single Zone VAV, Multi-Speed, and 17<br>Plus . . . . .                                      | 54 |   |    |
| Features and Operation - Voyager™ Light<br>Commercial, Precedent™ and<br>Odyssey™ . . . . . | 54 |   |    |
| Enhanced Dehumidification . . . . .   | 54 |   |    |
| General Sequence of Evaporator Fan<br>Operation . . . . .                                   | 54 |   |    |

## Table of Contents

|  |    |  |    |
|--|----|--|----|
| Mode Transitions .....   | 71 | Hardware Over - Current Limit – Error Code:<br>E-03 .....                              | 81 |
| Occupied Heating Operation .....   | 71 | Drive Operation Failure – Error Code:<br>E-04 .....                                    | 81 |
| Heating Sequence .....   | 71 | Software Over-Current Limits –<br>Protection Code: P-01 and Error Code:<br>E-05 .....  | 81 |
| Modulating Heat Operation with<br>Traditional Constant Volume Fan<br>Operation .....         | 72 | Output Current Sampling Error – Error<br>Code: E-06 .....                              | 82 |
| Supply Air Tempering Operation .....   | 72 | Heat Sink Over Heat - Protection Code<br>P-02 and Error Code: E-07 .....               | 82 |
| Dehumidification Operation .....   | 72 | DC Bus Over Voltage and Under<br>Voltage – Error Code: E-08 .....                      | 82 |
| Variable Speed (VSPD) Compressor<br>Control (eFlex™) .....                                   | 74 | Incorrect Compressor Code – Error<br>Code: E-09 .....                                  | 82 |
| Multi-Zone VAV Cooling (Traditional<br>VAV) .....  | 76 | Heat Sink Temperature Sensor Error –<br>Error Code: E-12 .....                         | 82 |
| Occupied DX and Economizing Cooling<br>Control .....   | 76 | Drive Board Internal Communication<br>Error – Error Code: E-13 .....                   | 82 |
| Unoccupied DX and Economizer<br>Cooling Control .....  | 76 | 3-Phase AC Input Power Phase-Loss –<br>Error Code: E-15 .....                          | 82 |
| Single Zone VAV Cooling - Supply Fan<br>Output Signal Control .....                          | 76 | Magnetic Field Weakening Control –<br>Protection Code: P-05 .....                      | 82 |
| Discharge Air Temperature Control .....  | 76 | Verifying Proper Airflow .....   | 83 |
| Occupied DX and Economizer Cooling<br>Control .....  | 76 | Precedent™ .....   | 83 |
| Unoccupied DX and Economizer<br>Cooling Control .....  | 76 | 3 to 5 Ton 17 Plus/WHC/DHC Units<br>with Constant CFM Direct Drive Indoor<br>Fan ..... | 83 |
| Enhanced Dehumidification .....  | 76 | Units with 5-Tap Direct Drive Indoor<br>Fan .....                                      | 83 |
| Active Cooling Mode Operation .....  | 77 | ReliaTel™ Units with Direct Drive<br>Indoor Plenum Fan .....                           | 84 |
| Idle Mode Operation .....  | 77 | ReliaTel™ Control .....  | 85 |
| Condenser Fan Control .....  | 77 | Electromechanical Control .....  | 85 |
| Test Modes .....   | 79 | Total System Airflow<br>(Electromechanical) .....                                      | 85 |
| Failure and Protection Conditions .....  | 79 | Fan Speed Adjustment .....   | 85 |
| Supply Air Temperature on SZVAV .....  | 79 | Voyager Light Commercial (12.5 to 25<br>Tons) .....                                    | 85 |
| Outside Air Temperature .....  | 79 | ReliaTel™ LED Functions .....  | 87 |
| Evaporator Coil Frost Protection .....   | 79 | Modules and Codes .....  | 87 |
| Extended Time at Compressor Low<br>Speed (Oil Recovery Mode) .....                           | 79 | BCI (BACnet®) .....  | 89 |
| High Ambient Operation Protection (3<br>to 5 ton and 12.5 to 17.5 ton eFlex™<br>Units) ..... | 79 | ReliaTel™ Test Mode .....  | 90 |
| Precedent™ 6 to 10 ton eFlex™<br>Emerson Compressor Enabled<br>Units .....                   | 79 | Protocol, Modes, and Tests .....   | 90 |
| Compressor Protection .....  | 80 | Protocol of Communications .....   | 90 |
| VSM Module Communication<br>Failure .....  | 80 | Service Test Mode .....  | 90 |
| Compressor VFD Alarm Output<br>Lockout .....   | 80 | Auto-Cycle Test .....  | 90 |
| VFD Troubleshooting and Support .....  | 80 | Resistance Test .....  | 90 |
| Variable Speed Compressor Drive<br>Troubleshooting .....                                     | 81 | Step Test .....  | 91 |
| Error and Protection Code List .....   | 81 | Test Modes .....   | 91 |
| Incorrect Dip Switch Settings – Error<br>Code: E0-1 .....                                    | 81 | Service Tips .....   | 91 |
| Communication Failure – Error Code:<br>E-02 .....  | 81 |  |    |

|  |     |   |     |
|--|-----|---|-----|
| Emergency Stop Input, LTB 5 and 6 (3J1-12 on RTRM) .....                       | 91  | Programmable Zone Sensor BAYSENS119* and BAYSENS019C (Obsolete) .....   | 125 |
| Fan Proving input, 5J7-6 on RTOM .....   | 91  | Testing the Programmable Zone Sensor (PZS) .....  | 125 |
| Compressor Disable Inputs, 3J1-8, 3J3-2 (Two Compressor Units) on RTRM .....   | 91  | Troubleshooting the Programmable Zone Sensor .....  | 125 |
| Compressor Proving Circuits, 3J1-9, 3J3-3 (Two Compressor Units) on RTRM ..... | 91  | RTRM/RTOM/RTDM - Temperature Inputs .....   | 127 |
| Ventilation Override Mode (VOM), J6 on the RTOM .....                          | 92  | Outdoor Air Sensor, Discharge Air Sensor, Coil Temperature Sensor, Entering Evaporator Temperature Sensor ..... | 127 |
| CO <sub>2</sub> Option Through DCV Input on ECA or RTEM .....                  | 92  | Terminals to Read Voltage .....   | 127 |
| ECA or RTEM Minimum Position Adjustment .....                                  | 92  | Service Tips .....  | 127 |
| Frostat™ Input .....   | 92  | Problems to Look for .....  | 127 |
| ReliaTel™ Test Mode Tables .....   | 93  | Zone Sensor Averaging .....   | 130 |
| Units with Two Heat Exchangers (High Heat Models) .....                        | 104 | COMM3/4 Interface .....   | 131 |
| ReliaTel™ Service Test .....   | 105 | Operation and Troubleshooting .....   | 131 |
| Thermostats and Sensors .....  | 109 | Wiring .....  | 131 |
| Protocol of Communications .....   | 109 | Compatibility .....   | 131 |
| BAYSENS016* Sensor with plug; Thermistor Sensor (OAT, SAS, RAT, CTS) .....     | 110 | LEDs .....  | 131 |
| BAYSENS106*/ASYSTAT106* .....  | 110 | Communication Problems .....  | 131 |
| BAYSENS107*/ASYSTAT107* .....  | 111 | Unit Addressing .....   | 133 |
| BAYSENS108*/ASYSTAT108* .....  | 111 | Direct Spark Ignition Control .....   | 134 |
| BAYSENS109*/ASYSTAT109* .....  | 112 | Precedent™ 3 to 10 tons only .....  | 134 |
| BAYSENS110* .....  | 112 | Sequence of Operation - Precedent™ 3 to 10 tons Only .....  | 135 |
| BAYSENS077* .....  | 113 | 1-Stage Units .....   | 135 |
| BAYSENS073* .....  | 113 | 2-Stage Units .....   | 135 |
| BAYSENS074* .....  | 114 | Precedent™ 6 to 10 Tons Modulating Gas Heat Units .....   | 135 |
| BAYSENS119* Programmable Zone sensor .....                                     | 114 | ReliaTel™ Hot Surface Ignition Control .....  | 138 |
| BAYSENS135* Non-Programmable Zone Sensor .....                                 | 116 | 12.5 to 50 Tons, 1 Stage, 2 Stage, and Modulating Gas Heat .....  | 138 |
| BAYSENS924* Programmable Zone Sensor Wiring .....                              | 117 | Ignition Control Module Diagnostics .....   | 138 |
| Operation with a Conventional Thermostat (Constant Volume) .....               | 119 | Sequence of Operations (1 and 2 heat units) .....   | 138 |
| Cooling/Economizer Operation .....   | 120 | Heat Pump .....   | 141 |
| Voyager 25 Tons 4 Stage Cooling .....  | 122 | Demand Defrost .....  | 141 |
| ZSM Control of 4 Stage Cooling .....   | 122 | Defrost Service Test .....  | 141 |
| Zone Sensor Module Testing .....   | 123 | Defrost Mode Operation .....  | 141 |
| Mechanical Zone Sensor Module .....  | 123 | General Sequence of Operation .....   | 141 |
| Temperature Input .....  | 123 | Emergency Heat Operation .....  | 142 |
| Setpoint Input .....   | 124 | Diagnostic Information .....  | 142 |
| Mode Input .....   | 124 | Independent Circuit Defrost Operation .....   | 143 |

## Table of Contents

|  |     |  |     |
|--|-----|--|-----|
| ReliaTel™ Heat Pump Low Ambient Limit .....                                  | 143 | Mechanical Zone Sensor BAYSENS006-11/AYSTAT661-664 .....   | 160 |
| Economizer .....   | 144 | Programmable Zone Sensor BAYSENS019*/AYSTAT666* .....  | 160 |
| ReliaTel™ .....  | 144 | COMM 3/4 (TCI) .....   | 160 |
| Economizer Module Layout .....   | 144 | LonTalk® (LCI) .....   | 160 |
| ReliaTel™ Economizer Layout - RTEM .....                                     | 145 | Voyager™ 27.5 to 50 tons VAV with Staged Heat .....  | 160 |
| Economizer Module and Actuator Layout .....                                  | 146 | Sequence of Operation .....  | 160 |
| VAV Economizer Cooling Operation .....                                       | 148 | Constant Volume Units with Staged Heat .....   | 160 |
| Economizer Operation with Zone Sensor, Programmable Zone Sensor or ICS ..... | 148 | Variable Air Volume Units .....  | 160 |
| Economizer Operation with Conventional Thermostat (CV Only) .....            | 148 | TCI Comm 3/4 .....   | 161 |
| Barometric Relief .....  | 148 | Discharge Air Sensing .....  | 161 |
| Motorized 0-50% Outside Air Damper .....                                     | 148 | 3 to 25 Tons Units .....   | 161 |
| Power Exhaust .....  | 149 | 27.5 to 50 Tons Units .....  | 161 |
| Economizer Control Methods .....   | 149 | Service Note .....   | 161 |
| Economizers with Traq (27.5 to 50 tons) .....                                | 150 | ReliaTel™ Ventilation Override .....   | 162 |
| Thermostat Notes .....   | 150 | Demand Control Ventilation (DCV) .....   | 163 |
| Economizer Damper Enthalpy Layout .....                                      | 151 | CO <sub>2</sub> Sensor Connections .....   | 163 |
| Economizer Operation Enthalpy Changeover .....                               | 151 | Using Multiple CO <sub>2</sub> Sensors to Monitor more than One Location .....                                   | 163 |
| ReliaTel™ Economizer Operation and Inputs .....                              | 152 | RTEM Operation .....   | 164 |
| Electromechanical Economizer .....   | 155 | RTEM with RTRM v8.0 and Later .....  | 164 |
| Electromechanical Economizer Testing .....                                   | 155 | DCV with Traq (27.5 to 50 Tons) .....  | 165 |
| Three Position Damper .....  | 156 | RTEM with RTRM v7.0 and Earlier .....  | 165 |
| Electromechanical Units .....  | 157 | Failure and Override Conditions .....  | 165 |
| Time Delay Relay .....   | 157 | Honeywell Operation .....  | 166 |
| Fan Off Delay Solid State Timer .....  | 157 | Precedent™, Voyager II, and Voyager III VAV/MZVAV Notes .....  | 166 |
| ReliaTel™ - Humidity Sensors .....   | 158 | Demand Controlled Ventilation (CO <sub>2</sub> ) Set-up for Single Zone VAV, Multi-Speed and 17 Plus units ..... | 166 |
| Outdoor Humidity Sensor .....  | 158 | Initial Set-up .....   | 168 |
| Return Humidity Sensor .....   | 158 | Set-up the LOW Fan Speed Damper Positions .....  | 168 |
| To Test Humidity Sensors .....   | 158 | Set-up the MEDIUM Fan Speed Damper Position .....  | 168 |
| ECA Module Voltages .....  | 159 | Set-up the HIGH Fan Speed Damper Positions .....   | 168 |
| RTEM Module Voltage .....  | 159 | Dehumidification .....   | 169 |
| ReliaTel™ - Supply Air Tempering Control .....                               | 160 | Hot Gas Reheat 3 to 25 Tons .....  | 169 |
| Enable Supply Air Tempering .....  | 160 | Sequence of Operation .....  | 169 |
|  |     | Modulating Dehumidification with Hot Gas Reheat (27.5 to 50 Tons) .....  | 170 |
|  |     | Controls Overview .....  | 170 |

|  |     |   |     |
|--|-----|---|-----|
| Heating/Cooling Changeover .....                                       | 172 | RTRM - ReliaTel™ Refrigeration Module -<br>(Standard) .....                             | 183 |
| Low Ambient Operation (3 to 25 Ton<br>Units) .....                     | 173 | RTOM - ReliaTel™ Options Module -<br>(Standard) .....                                   | 183 |
| Evaporator Defrost Control (EDC)<br>Function .....                     | 173 | RTAM - ReliaTel™ Air Handler Module<br>- (Standard on VAV) .....                        | 183 |
| Low Ambient Kits .....   | 173 | ECA or RTEM - Economizer Actuator -<br>(Optional) .....                                 | 183 |
| Precedent™ .....   | 173 | TCI - Trane® Communication Interface<br>- (Optional) .....                              | 184 |
| Voyager 12.5 to 25 Tons Packaged<br>Rooftop Units .....                | 173 | LCI - LonTalk® Communication<br>Interface (optional) .....                              | 184 |
| Evaporator Defrost Control<br>(Frostat™) .....                         | 173 | IGN - Ignition Control Module (YC*<br>only) .....                                       | 184 |
| Head Pressure Control .....  | 173 | Configuration Input .....   | 184 |
| Odyssey .....  | 174 | Supply Duct Static Pressure<br>Control .....  | 185 |
| ReliaTel™ - Condenser Fan .....  | 175 | Modes of Operation .....  | 185 |
| Control Logic - 12.5 to 25 Tons .....                                  | 175 | VHR Relay .....   | 186 |
| Sequence for eFlex™ Units .....  | 175 | Troubleshooting Tips .....  | 186 |
| Sequencing Control - 27.5 to 50 Tons .....                             | 175 | Application Notes .....   | 186 |
| Independent Circuit Heat Pump -<br>Odyssey™ .....                      | 178 | BAYSENS021* Setpoint Input .....  | 187 |
| Phase Monitor .....  | 179 | Remote Setpoint Inputs on RTAM<br>J7 .....  | 187 |
| ReliaTel™ 3 to 25 Tons .....   | 179 | MZVAV Morning/Daytime Warm-up .....   | 190 |
| Circuits .....   | 180 | Morning Warm-up .....   | 190 |
| Snubber Circuits .....   | 180 | Daytime Warm-up .....   | 190 |
| High Pressure and Low Pressure Lockout<br>Circuits .....               | 180 | VHR Relay .....   | 190 |
| LPC Logic .....  | 180 | MZVAV Unoccupied Heating/Cooling .....  | 190 |
| LPC Sequence of Operation .....  | 180 | MZVAV in Local Mode (No BAS, No<br>Programmable Zone Sensor) .....                      | 190 |
| LPC Operation for 27.5 to 50 Ton Units<br>with Modulating Reheat ..... | 180 | MZVAV with BAS or Programmable<br>Zone Sensor .....                                     | 190 |
| HPC Logic .....  | 181 | Outdoor Airflow Compensation for MZVAV<br>Units .....                                   | 192 |
| HPC Sequence of Operation .....  | 181 | 3 to 50 Tons .....  | 192 |
| Transformer Troubleshooting .....                                      | 182 | Setup .....   | 192 |
| Constant Volume (CV) and Variable Air<br>Volume (VAV) .....            | 183 | Operation for RTRM 7.0 and Earlier<br>with RTEM or Any RTRM with<br>Honeywell ECA ..... | 192 |
| Constant Volume (CV) .....   | 183 | Operation for RTRM 8.0 and Later with<br>RTEM .....                                     | 192 |
| Variable Air Volume (VAV) .....  | 183 |   |     |
| VAV with ReliaTel™ versus VAV with<br>UCP .....                        | 183 |   |     |

# General Information

## ReliaTel™

ReliaTel™ is not the name of a circuit board, but an overall communicating control system consisting of up to eight communicating modules.

ReliaTel™ is the second generation microprocessor controls developed by Trane®.

ReliaTel™ controls were first used in 3 to 10 ton convertible packaged cooling with electric heat, gas/electric, and heat pumps. In April 2003, Voyager™ 12.5 to 25 tons dedicated units were converted to ReliaTel™ controls. In April 2004, ReliaTel™ controls were added to Voyager™ Commercial 27.5 to 50 tons dedicated units.

## Precedent™ 3 to 10 Tons and Voyager™ 12.5 to 50 Tons Dedicated Packaged Rooftops

Precedent™ 3 to 10 ton cooling only and gas/electric convertible packaged units can be built with either electromechanical or ReliaTel™ controls. Voyager™ 12.5 to 50 ton units are built with ReliaTel™ controls. All heat pumps are built exclusively with ReliaTel™ controls. This publication covers both electromechanical and ReliaTel™ controls. Due to the more complex application and service opportunities, greater emphasis is placed on units with ReliaTel™ controls.

## Odyssey™

Odyssey™ 6 to 20 ton heat pumps are available with ReliaTel™ controls. Odyssey™ 6 to 25 ton cooling only units can be built with either electromechanical or ReliaTel™ controls.

## ReliaTel™ vs. Electromechanical

**Note:** Each ReliaTel™ module is a communicating control.

Precedent™ 3 to 10 tons packaged gas/electric (YSC, YHC) and cooling only (TSC, THC) are available without microprocessor controls. With electromechanical controls, zone sensors cannot control the units, or communicate with building automation systems. Electromechanical units require the use of a thermostat or relay based control system to directly control relays, contactors, etc. The ignition control and economizer are different than the ones used with ReliaTel™. Service information for these components are handled separately in this book.

- ReliaTel™ controls: 9th digit "R"
- Electromechanical controls: 9th digit "E"
- 27.5 to 50 tons: ReliaTel™ controls 10th digit "M" or greater

## ReliaTel™ Refrigeration Module (RTRM)

Every ReliaTel™ unit uses an RTRM. The RTRM provides primary unit control for heating and cooling. In addition, it

has built-in logic that controls heating and cooling staging, minimum run times, diagnostics, heat pump defrost control, short cycle timing and more. It can be controlled directly by any of the following:

- Mechanical Zone Sensor Module (ZSM)  
BAYSENS106-111\*, AYSTAT106\*-109\*
- Programmable Zone Sensor (BAYSENS119\*, 20\*, AYSTAT666\*)
- Conventional thermostat BAYSTAT036-038\* (or similar, ASYSTAT701-703\*)

**Note:** Unlike the previous Micro, a conventional thermostat does not require any sort of interface. It can be wired directly to the RTRM.

In addition, the unit can be controlled using Trane® ICS systems by applying the appropriate interface. The RTRM is configured through the unit wiring harness. The same module is used on gas/electric, cooling only with electric heat, and heat pumps. The following additional inputs are connected to the RTRM:

- Outdoor air sensor (OAT)
- Coil temperature sensor (CTS) heat pump only
- Smoke detector (unless it is factory installed) or other shutdown device

## ReliaTel™ Air Handler Module (RTAM)

The RTAM is the module required for units with multi-zone VAV function. The RTAM gets power from and communicates with the RTRM via RS-485 bus. This module contains the VAV setpoint potentiometers as well as the following inputs and outputs:

- DIP switch inputs for supply air reset, daytime warm-up enable and IGV/VFD configuration.
- Supply pressure transducer input inlet guide vane (IGV) or variable frequency drive (VFD) output.
- Ventilation heat relay (VHR) output.

## ReliaTel™ Option Module (RTOM)

**Note:** RTOM is standard on 27.5 to 50 Tons units.

The RTOM gets power from and communicates with the RTRM.

Any of these optional ReliaTel™ devices require the use of an RTOM:

- Condensate overflow switch (COS)
- Clogged filter switch (CFS)
- Discharge air sensor (DAT) used for supply air tempering and ICS input data
- Fan failure switch (FFS)
- Factory-installed smoke detector

**Note:** A factory-installed smoke detector provides instant shutdown and ICS alarm output.

- Frostat™ (FOS)

### ReliaTel™ Ventilation Module (RTVM) — 27.5 to 50 Tons Units

The RTVM is a module required for units configured with space pressure control with Statitrac™. The module controls the exhaust damper position 0-10 Vdc output as well as the space pressure sensor calibration routine. The module accepts the following inputs:

- Statitrac™ configuration
- Space pressure input
- Space pressure setpoint
- Space pressure setpoint deadband
- Traq™ (Voyager™ Commercial 27.5 to 50 tons)

### ReliaTel™ Ventilation Module (RTVM) — 3 to 25 Tons Units

The RTVM is a module for Demand Control Ventilation (DCV) on multi-speed and Single-Zone Variable Air Volume (SZVAV) units.

- DCV minimum position at minimum fan speed (R41)
- Design minimum Position at minimum fan speed (R130)
- Design minimum position at mid fan speed (R136)
- Precedent mod gas airflow measurement

### ReliaTel™ Dehumidification Module (RTDM)

*Note: Available on 27.5 to 50 Tons units only.*

The RTDM is a module required for units configured with modulating dehumidification. The module controls modulating cooling and reheat valves as well as the reheat circuit pumpout solenoid. The module accepts the following inputs:

- Reheat circuit entering evaporator temperature
- Reheat circuit low pressure cutout input

### Economizer Actuator with Module (ECA or RTEM)

The economizer can be used with or without the options module. The actuator has a detachable communicating module, which can be replaced separately. The outdoor air sensor, connected to the RTRM, provides outdoor temperature information for the changeover decision.

The ECA or RTEM accepts the following inputs:

- Mixed air sensor (MAT)
- Return air sensor (RAT) for comparative enthalpy or ICS input data
- Outdoor humidity sensor (OAH) for reference or comparative enthalpy

- Return air humidity sensor (RAH) for comparative enthalpy
- CO<sub>2</sub> sensor 0-10 Vdc input (DCV)
- Remote minimum potentiometer (RMP)
- Active/passive DCV configuration input (RTEM only)
- The power exhaust relay is connected to the ECA or RTEM module

### ReliaTel™ Electromechanical Economizer Module (RTEM-EM)

The RTEM-EM is an economizer module configured to support electromechanical HVAC units. The module will require 24 Vac input power and provide control for an outdoor air damper actuator. The module features 6 potentiometers onboard. The potentiometers control building design and demand control ventilation (DCV) minimum damper positions, DCV and CO<sub>2</sub> setpoints and limits, exhaust fan setpoint, and dry bulb and enthalpy settings. The module supports the following inputs:

- Return air temperature sensor (RAT)
- Outside air temperature sensor (OAT)
- Mixed air temperature sensor (MAT)
- Return air humidity sensor (RAH) for comparative enthalpy
- Outside air humidity sensor (OAH) for comparative enthalpy
- CO<sub>2</sub> sensor 0-10 Vdc input (DCV)
- Remote minimum position potentiometer

### Variable Speed Module (VSM)

- The VSM allows communication between ReliaTel™ controls platform and a variable speed condenser fan (ECM) motor and variable speed compressor drive for Precedent™ and Voyager™ light commercial products. The VSM controller is applied to the following units:
- Precedent™ 3 to 5 ton units to control a variable speed condenser fan and variable speed compressor drive.
- Voyager™ light commercial 12.5 and 17.5 ton units to control a variable speed condenser fan and variable speed compressor drive.

### COMM3/4 Communication Interface

Allows ICS communication between a ReliaTel™ unit and Trane® ICS systems as follows:

- Tracer® 100™ series
- Tracer® Summit®
- Tracker®
- ComforTrac™
- VariTrac® 1 (Comfort Manager)
- VariTrac® 2 (Central Control Panel)

### LonTalk® Communication Interface

#### General Information

The communication interface board allows ReliaTel™ controls to communicate on a LonTalk® network at the unit level. This product is intended to be installed by a qualified system integrator properly trained and experienced in LonTalk® networks. Network variables are based on the LonMark® functional profile template. The LCI-R utilizes a Free Topology transceiver FTT-10A. The FTT-10A transceiver supports non-polarity sensitive, free topology wiring, allowing the system installer to utilize star, bus, and loop architecture.

#### Storage

When the LCI-R board must be stored for a period of time prior to being installed, it must be protected from the elements. The temperature of the storage location should be between -40°C and 65.6°C (-40°F and 150°F) and the relative humidity should be 10 to 90 percent, non-condensing.

#### Mounting and Wiring

The LCI-R board mounts directly in the unit control box.

#### Shipment and Inspection - LCI-R

The LCI-R kit includes the following items:

- One (1) LCI-R communications board
- One (1) Wire harness
- Four (4) LCI-R board mounting screws
- One (1) Pop-in wire tie (BAYLTIC1002\*)

### ReliaTel™ BACnet® Communication Interface (BCI-R)

#### General Information

The building automation and control network (BACnet® and ANSI/ASHRAE Standard 135-2004) protocol is a standard that allows building automation systems or components from different manufacturers to share information and control functions. The BACnet® communication interface for ReliaTel™ supports Trane® ReliaTel™ rooftop units that function as part of a BACnet® MS/TP communications network. It allows ReliaTel™ equipment to communicate with a building automation system (BAS) by using BACnet® protocol over an RS-485 MS/TP communications link. The BCI-R module implements all the required BACnet® capabilities for a BACnet® Application Specific Controller (B-ASC). This product is intended to be installed by a qualified system integrator properly trained and experienced in BACnet® networks. The BCI-R supports three product families that use the ReliaTel™ controls platform: Precedent™, Voyager™, and Odyssey™.

#### BCI-R Shipment and Inspection

BCI-R kits include the following items:

- One (1) BCI-R communications board
- One (1) Wire harness
- Four (4) BCI-R board mounting screws
- One (1) Pop-in wire tie

#### Storage

When the BCI-R board must be stored for a period of time prior to being installed, it must be protected from the elements. The temperature of the storage location should be between -40°C and 65.6°C (-40°F and 150°F) and the relative humidity should be 10 to 90 percent, non-condensing.



# Module Flow Diagram

Figure 1. Precedent™ (TSC/THC) refrigeration module (RTRM) electric heat/no heat

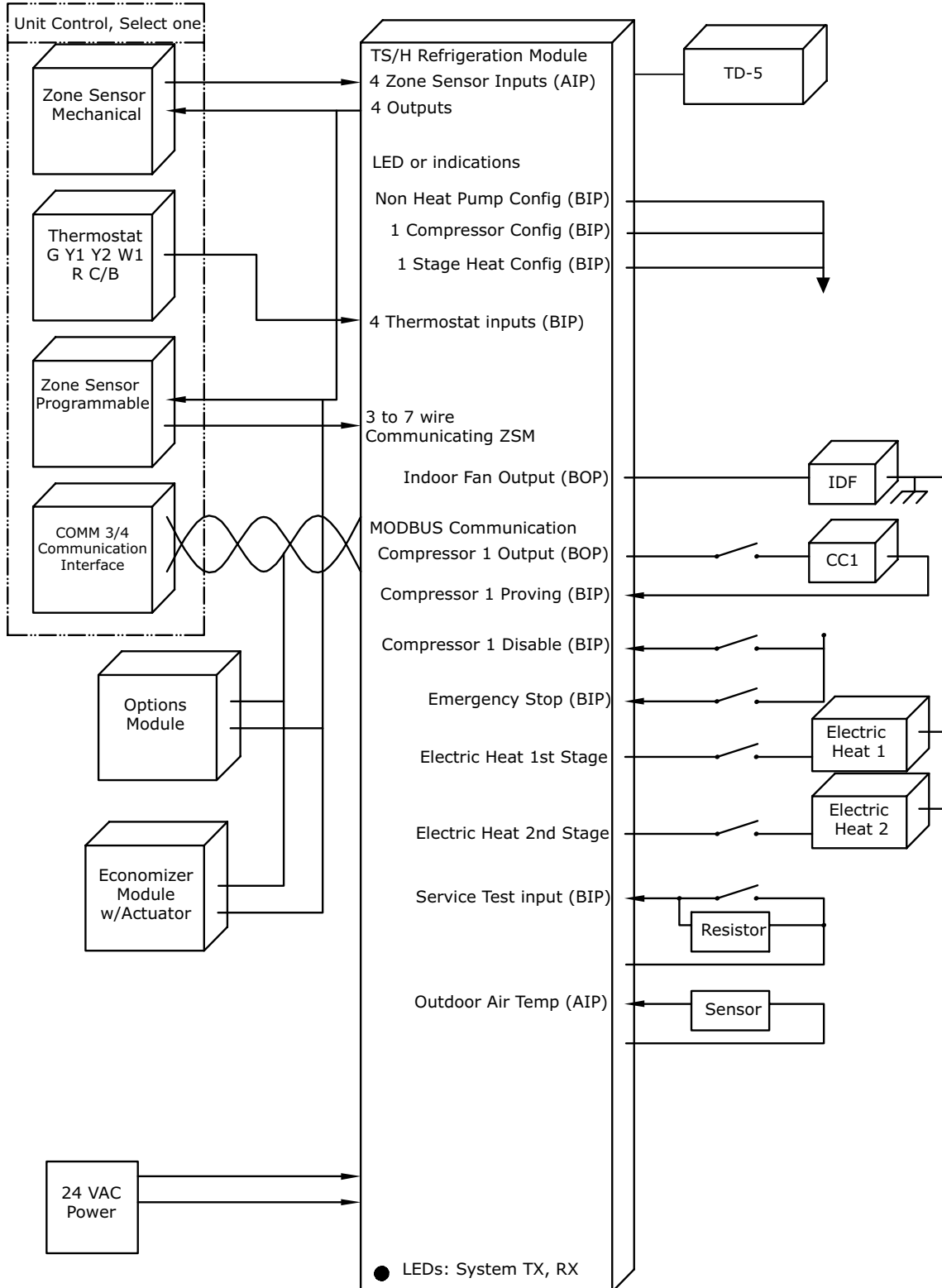

# Module Flow Diagram

Figure 2. Precedent™ (YSC/YHC) refrigeration module (RTRM) gas heating

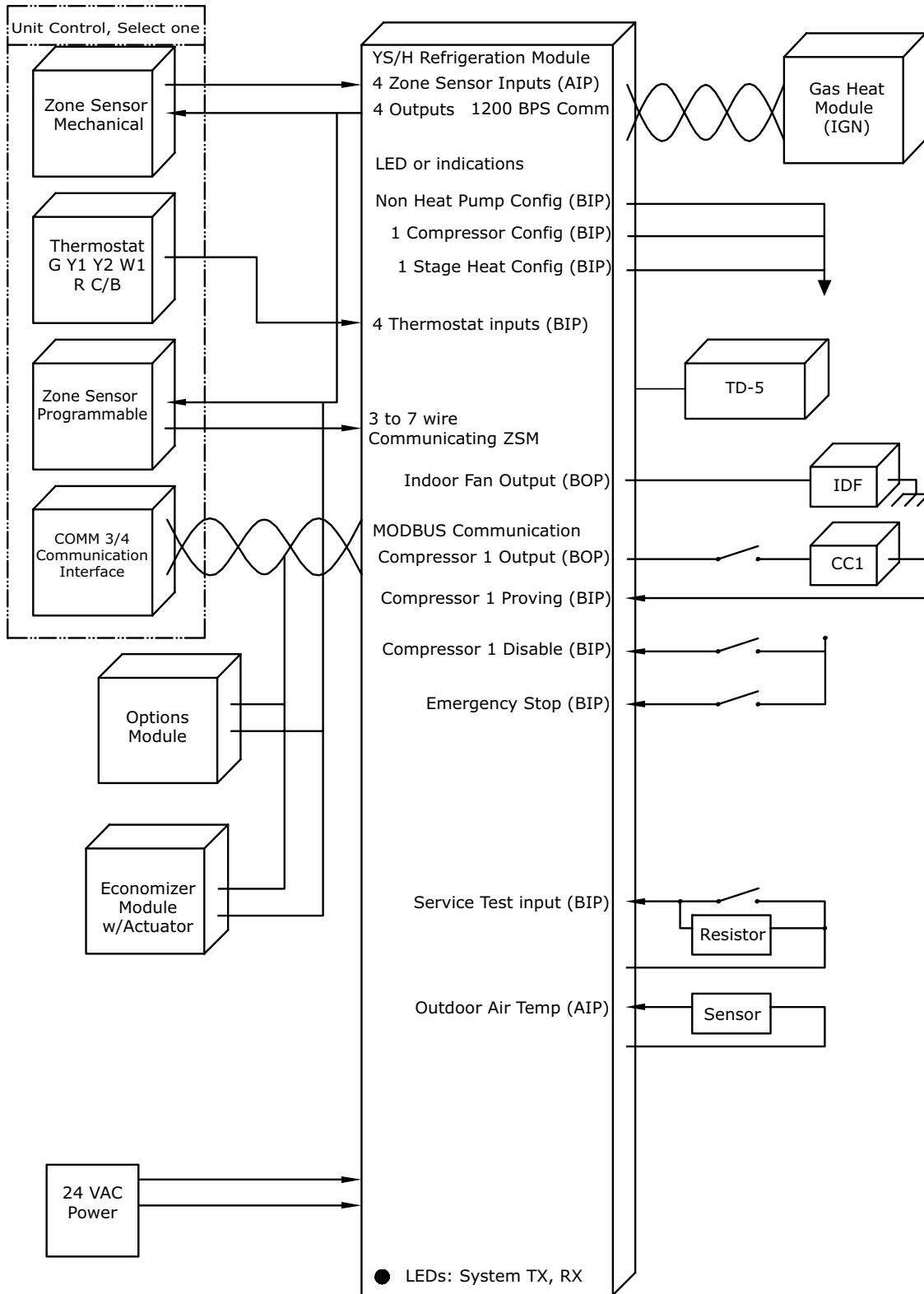
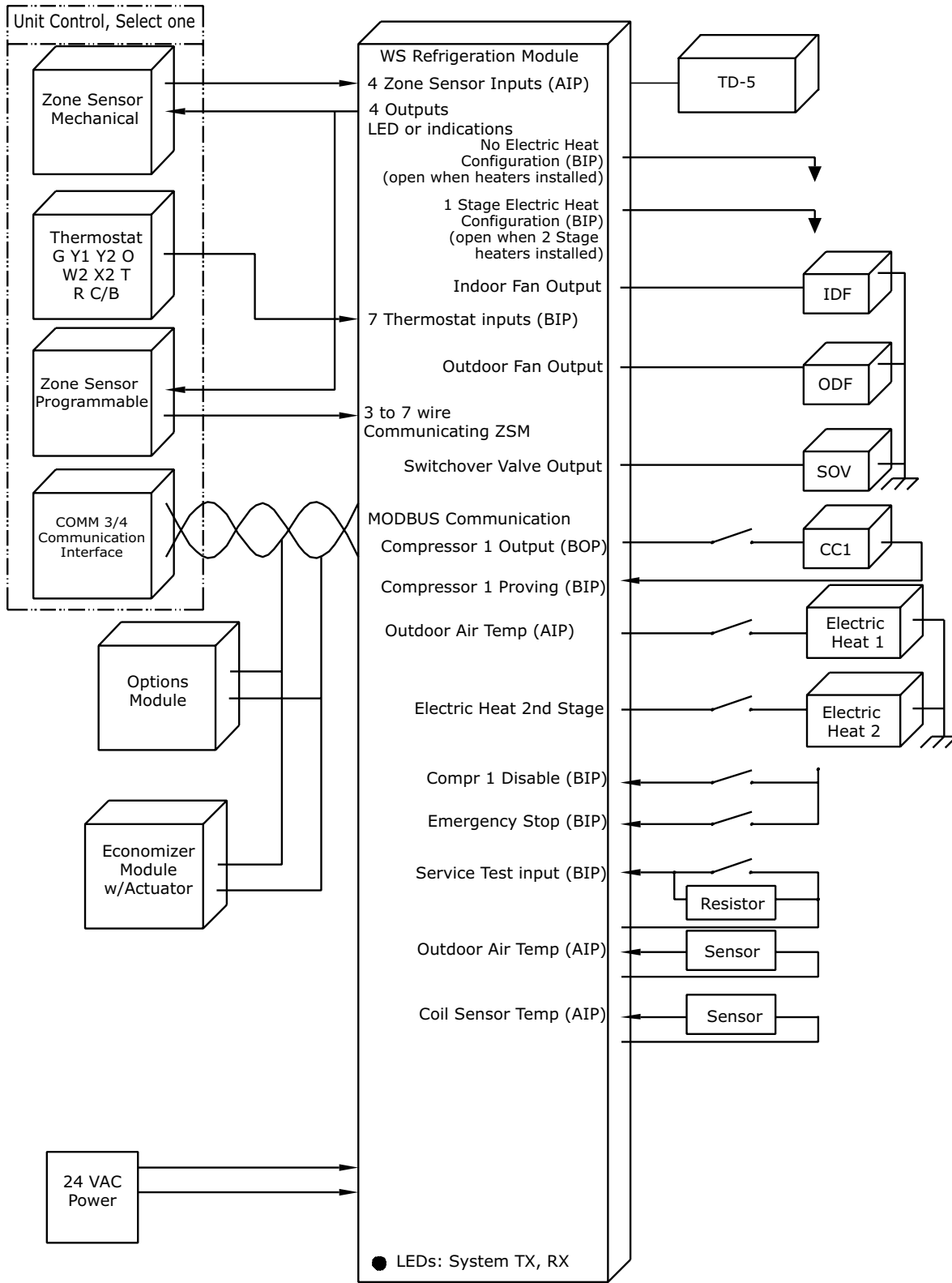

Figure 3. Precedent™ (WSC) refrigeration module (RTRM) heat pump



# Module Flow Diagram

Figure 4. Options module (RTOM)

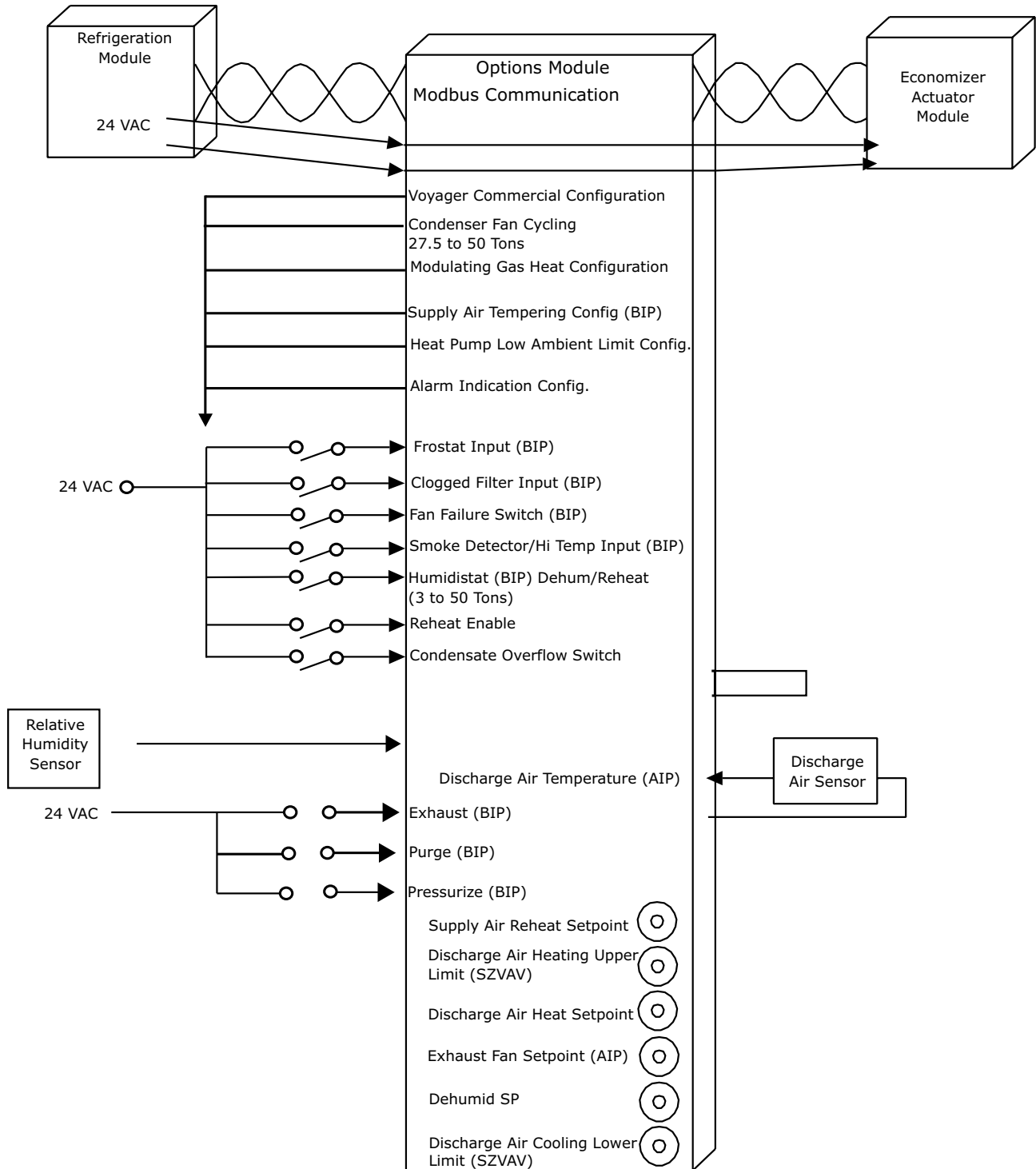
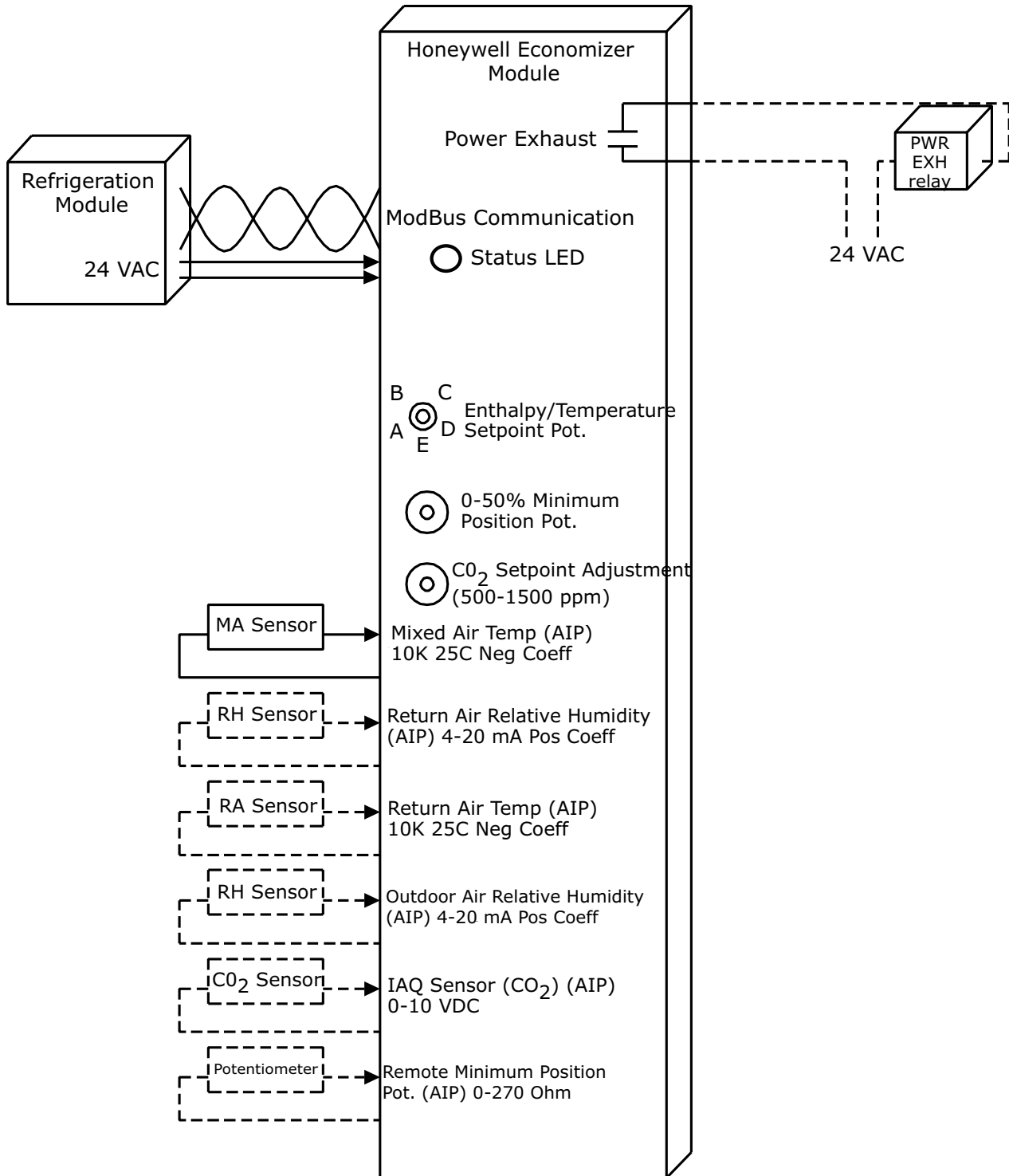

Figure 5. Honeywell economizer module (ECA)



**Note:** Not available to order (obsolete).

# Module Flow Diagram

Figure 6. Economizer module (RTEM)

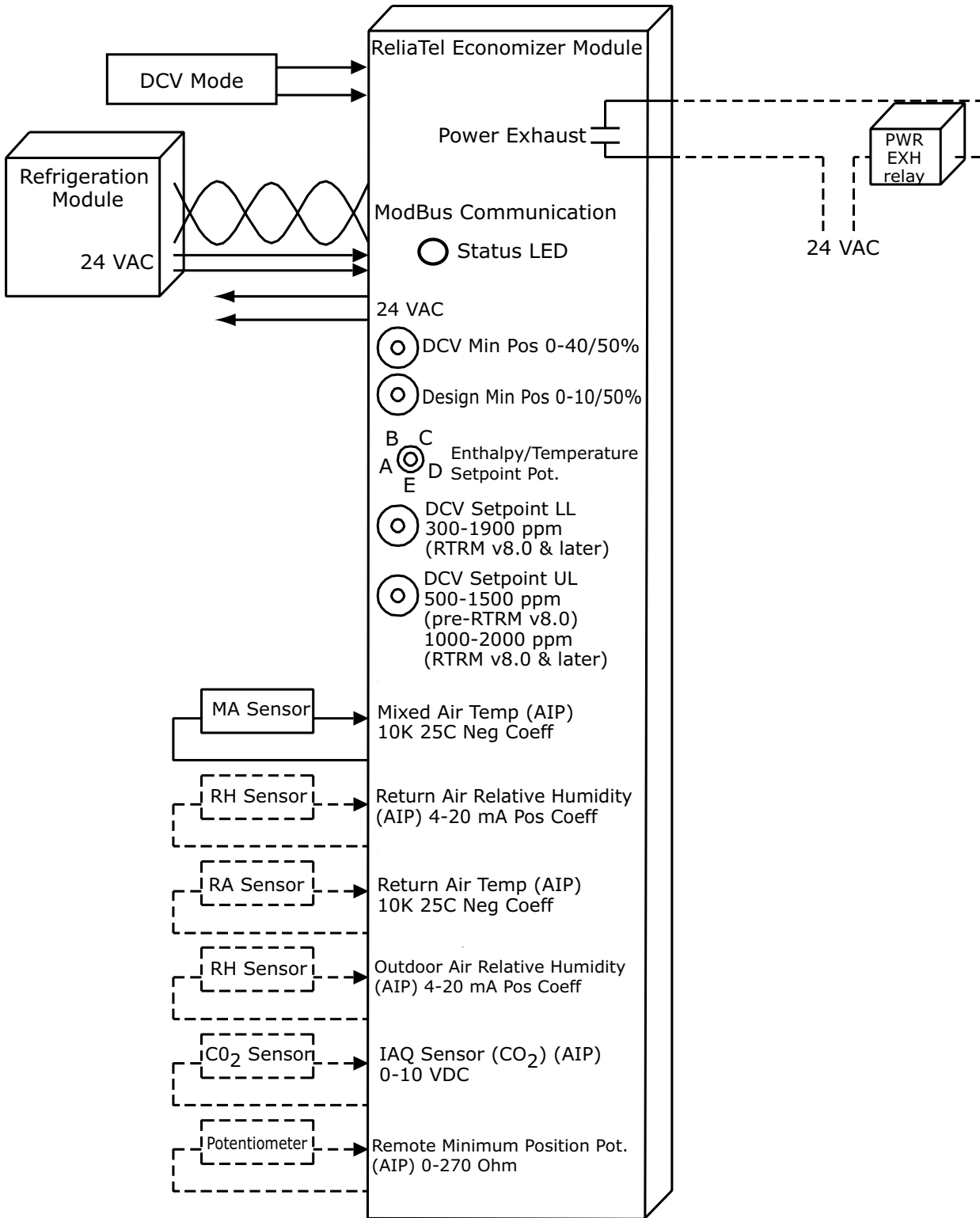
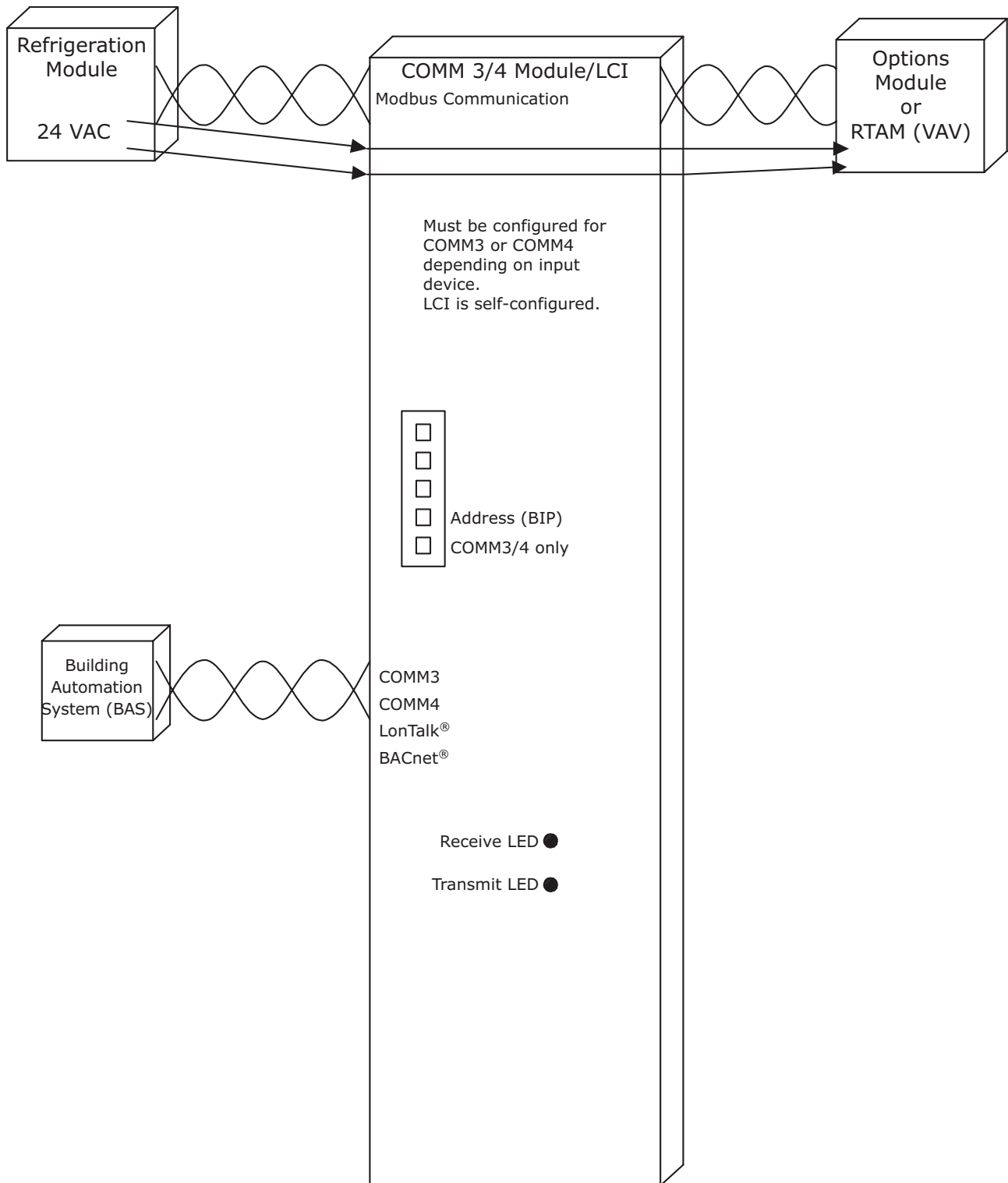

Figure 7. COMM 3/4 module for ICS communication/ LonTalk® Communication Interface (LCI/TCI), BACnet™ (BCI)



# Module Flow Diagram

Figure 8. Air control module (RTAM)

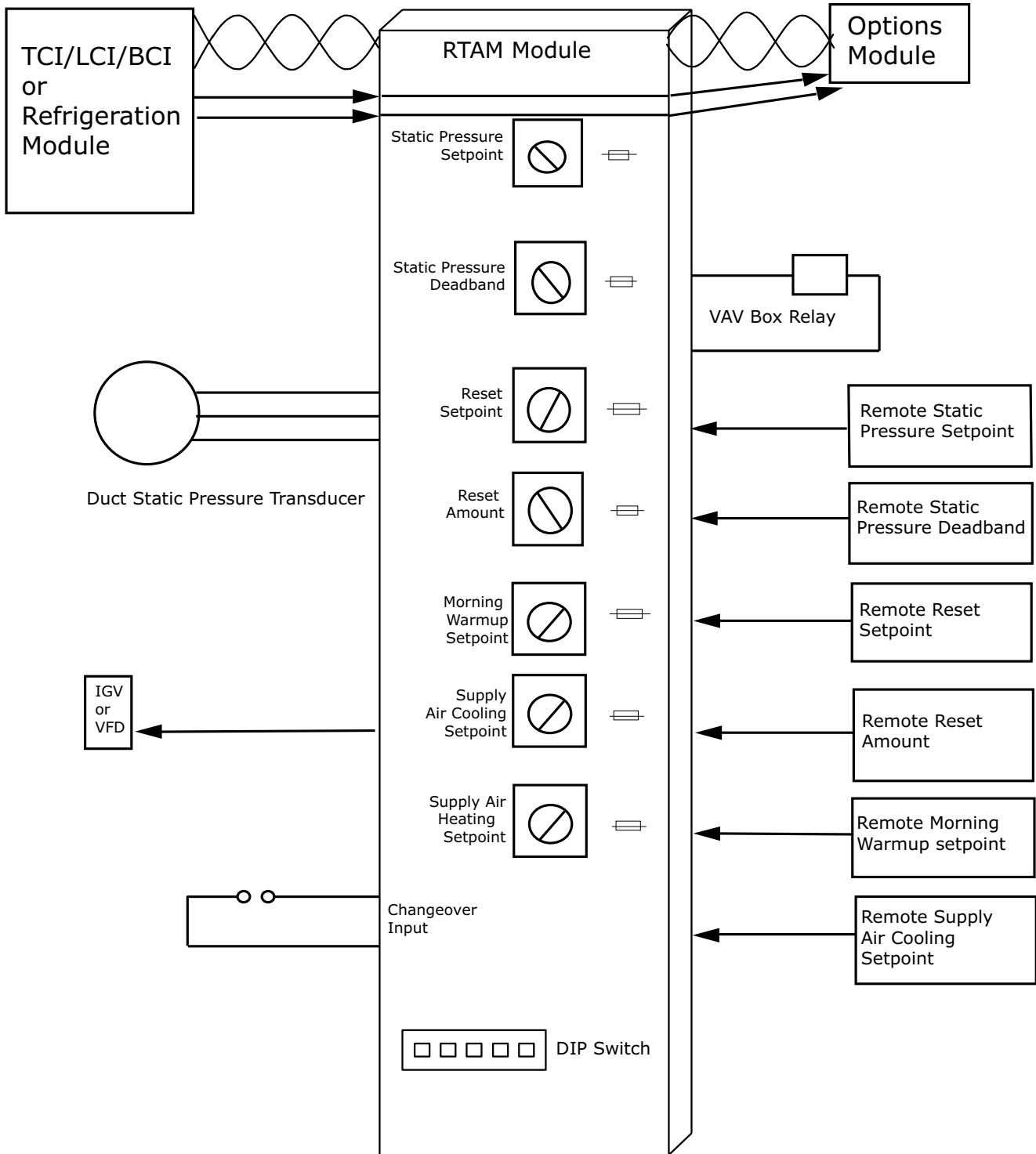
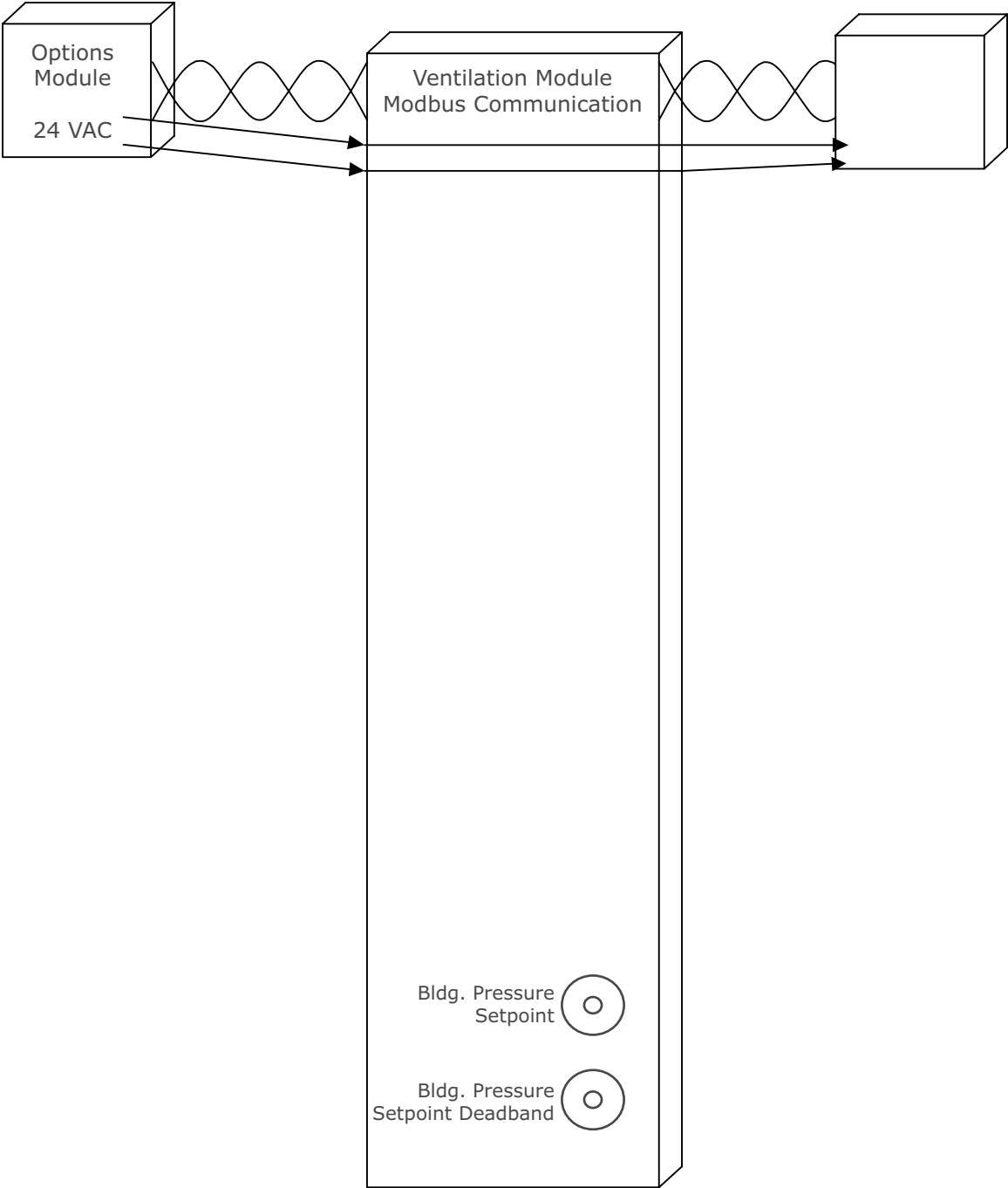



Figure 9. ReliaTel™ ventilation module (RTVM) - 3 to 25 tons



# Module Flow Diagram

Figure 10. ReliaTel™ ventilation module (RTVM) - 27.5 to 50 tons

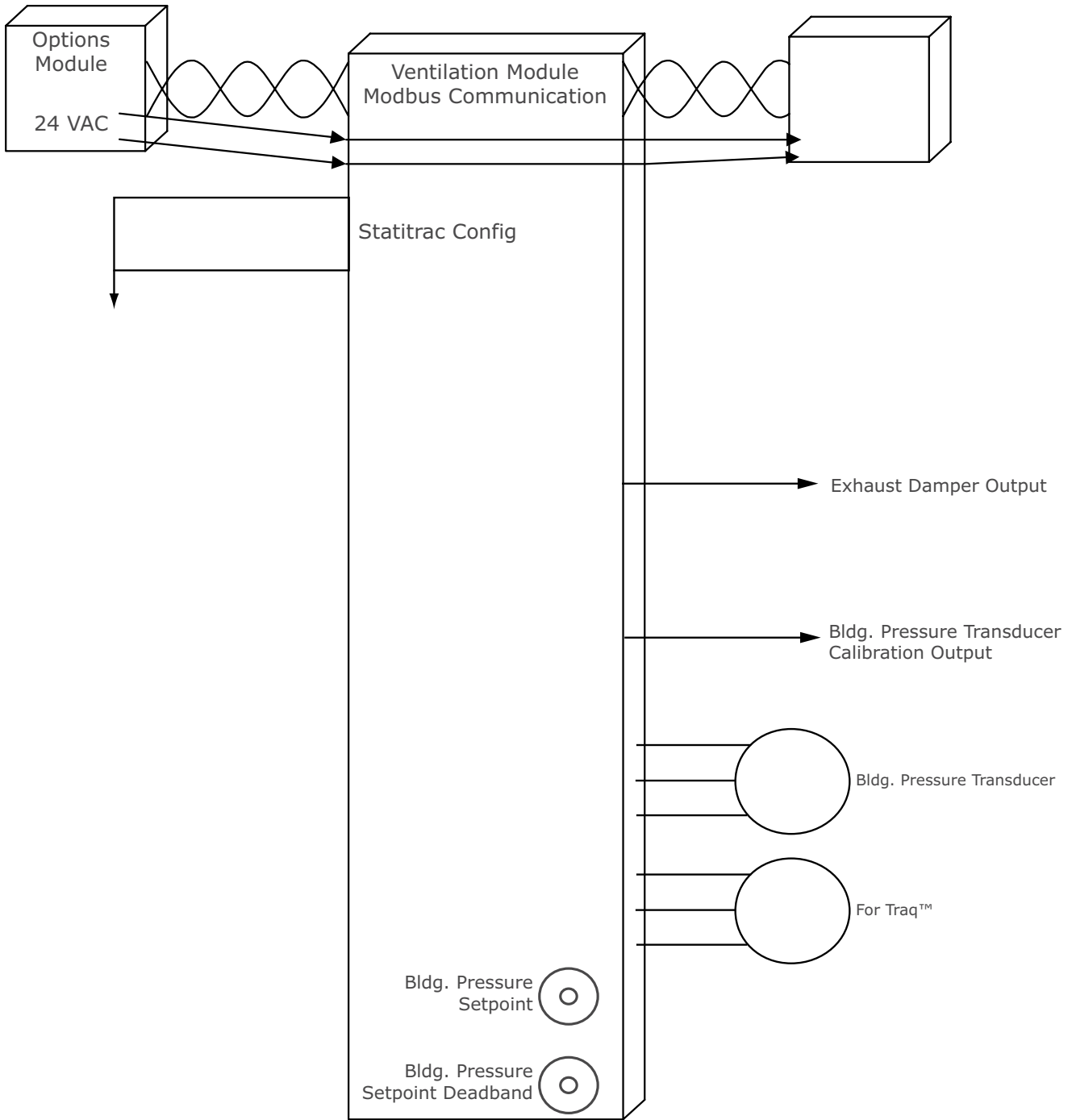

Figure 11. ReliaTel™ dehumidification module (RTDM) - 27.5 to 50 tons only

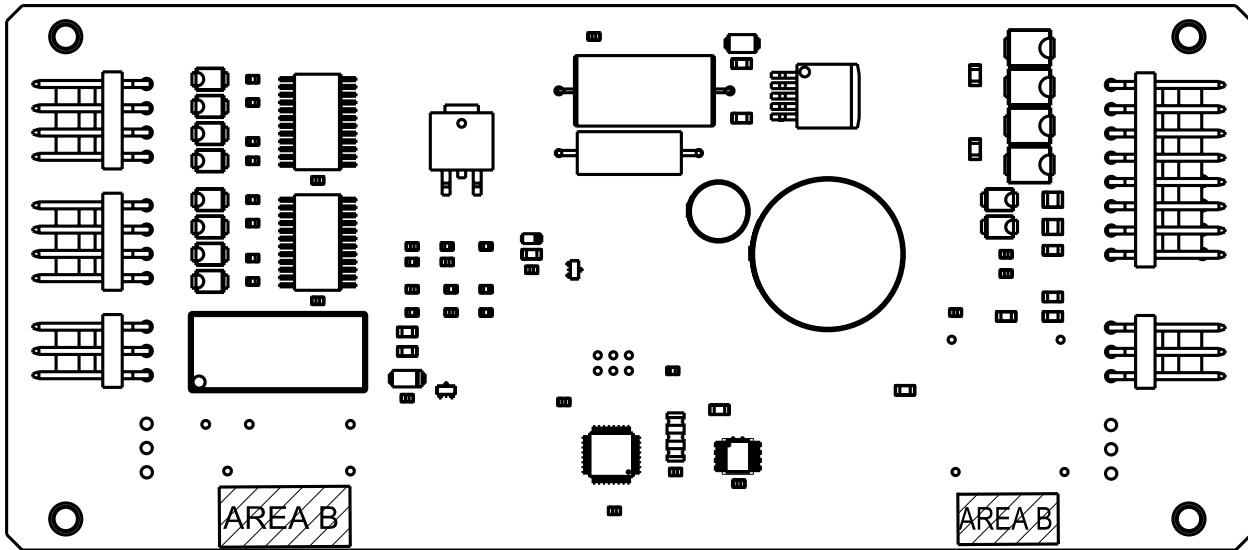
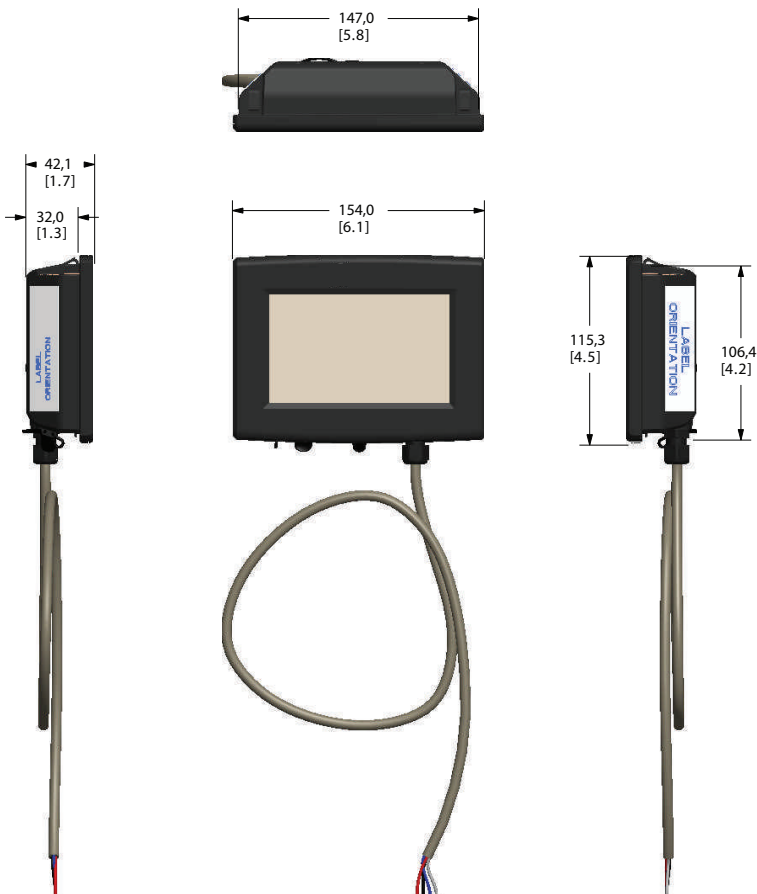
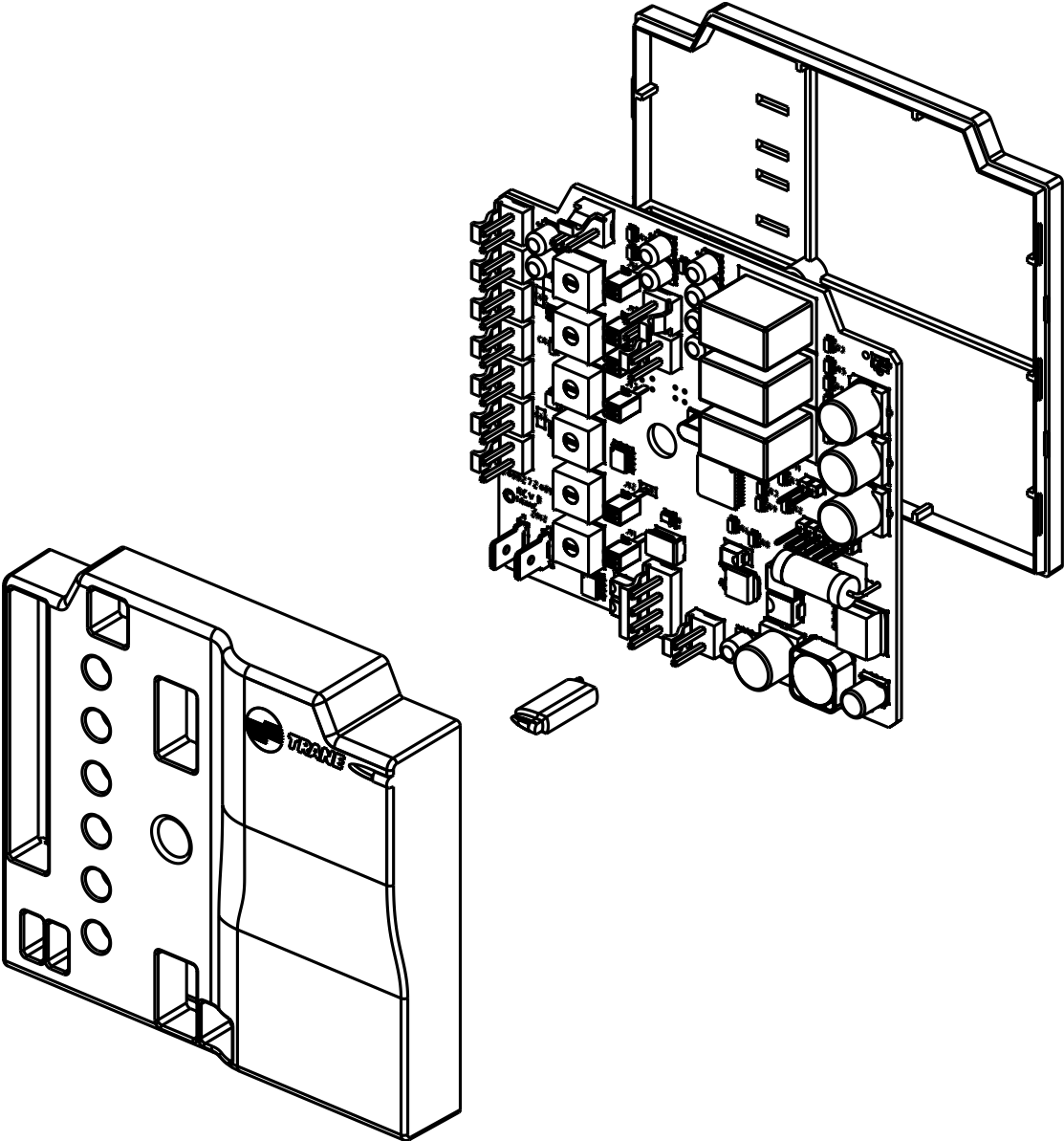

Figure 12. ReliaTel™ TD-5 human interface — Trane part number CNT07131



**Note:** For additional information, refer to RT-SVX49\*-EN.

Figure 13. Electromechanical logic module - RTEM-EM



# Low Voltage Terminal Boards

## LVTB – 01 (Part # BLK00940)

**TEST1, TEST2** Test Terminals - By jumpering from TEST1 to TEST2, the service technician can test the unit or start it with or without any controls attached. See “ReliaTel™ Test Mode,” p. 90 for details.

**CPR1**, Compressor 1 disable - If the factory installed jumper from 1 to 2 is removed (compressor 1 disable), compressor 1 will not run, even in the TEST MODE. This is where a load shedding device could be connected.

**CPR2**, Compressor 2 disable - If the factory installed jumper from 3 to 4 is removed (compressor 2 disable), compressor 2 will not run, even in the TEST MODE. This is where a load shedding device could be connected.

**ESTOP**, Emergency Stop - If the factory installed jumper from 5 to 6 is removed (emergency stop), the unit will not run. The RTRM system LED will be on. The unit will have heat + cool diagnostic. An external smoke detector or other interlock device can be added here.

**Figure 14. Low voltage terminal board – 01, Part #BLK00940**

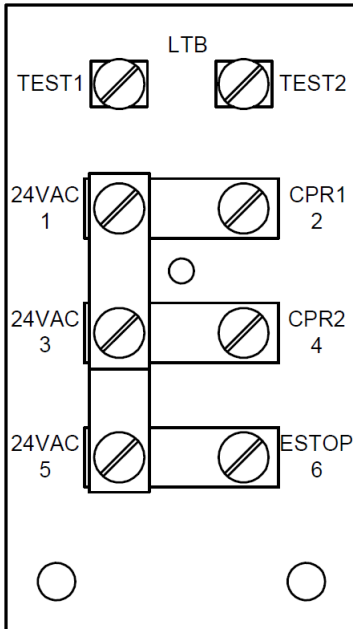

## LVTB – 02 (Part # TER00116)

**PRS**, Pressurization – With 24 Vac applied, supply fan forced ON, NO Compressor or Heating operation, Economizer Position 100%. For pressurize, exhaust fan should be off.

**PUR**, Purge - With 24 Vac applied, Supply fan forced ON, NO Compressor or Heating operation, Economizer Position 100%, and Power Exhaust ON.

**EXH**, Exhaust – With 24 Vac applied, Supply fan forced OFF, NO Compressor or Heating operation, Economizer Position 0%, and Power Exhaust ON.

**HUM**, Humidity – With 24 Vac applied from Humidistat provides to energize the reheat valve for dehumidification. When the humidistat is satisfied, the reheat valve is de-energized.

**CO<sub>2</sub><sup>+</sup>, CO<sub>2</sub><sup>-</sup>**. Demand Control Ventilation – Hardwired CO<sub>2</sub> sensor 0-10 Vdc input for Demand Control Ventilation (DCV), polarity sensitive

**Figure 15. Low voltage terminal board – 02, Part #TER00116**

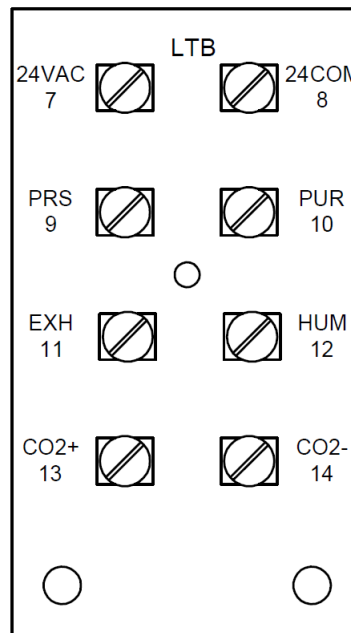

## LVTB – 03 (Part # TER01406)

**RH<sup>+</sup>, RH<sup>-</sup>**. Relative Humidity – Hardwired Space Humidity or Return Duct Humidity sensor 4-20ma input for Dehumidification, polarity sensitive.

## Low Voltage Terminal Boards

**Figure 16. Low voltage terminal board – 03, Part #TER01406**

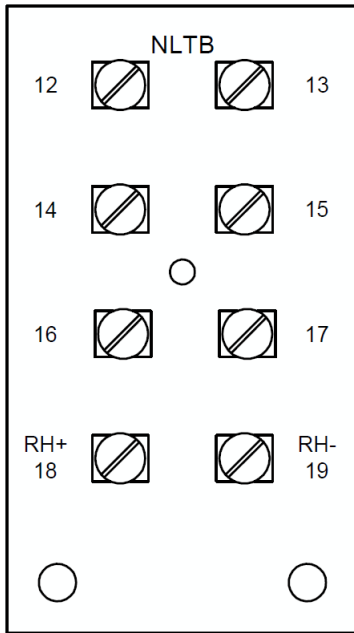

### LVTB – 04 (Part # BLK01455)

**VHR-COM.** Ventilation Heat Relay, Common.

**VHR-NO.** Ventilation Heat Relay, Normally Open Contacts  
- Can be used for the purpose of commanding the VAV boxes to drive open to maximum airflow position during MAX heat operation.

**VHR-NC.** Ventilation Heat Relay, Normally Closed Contacts - Can be used for the purpose of commanding the

VAV boxes to drive open to maximum airflow position during MAX heat operation.

**RH+, RH-.** Relative Humidity – Hardwired Space Humidity or Return Duct Humidity sensor 4-20ma input for Dehumidification, polarity sensitive.

**SAH+, SAH-.** Supply Air Heating Setpoint – Modulating Gas Heat Changeover Switch Input for Discharge Air Heating (MZVAV only).

**Figure 17. Low voltage terminal board – 04, Part #BLK01455**

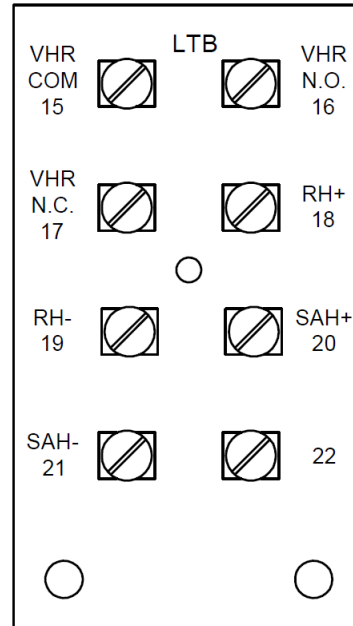

# Typical Control Box Layout

Figure 18. Typical control box layout (3 to 5 tons)

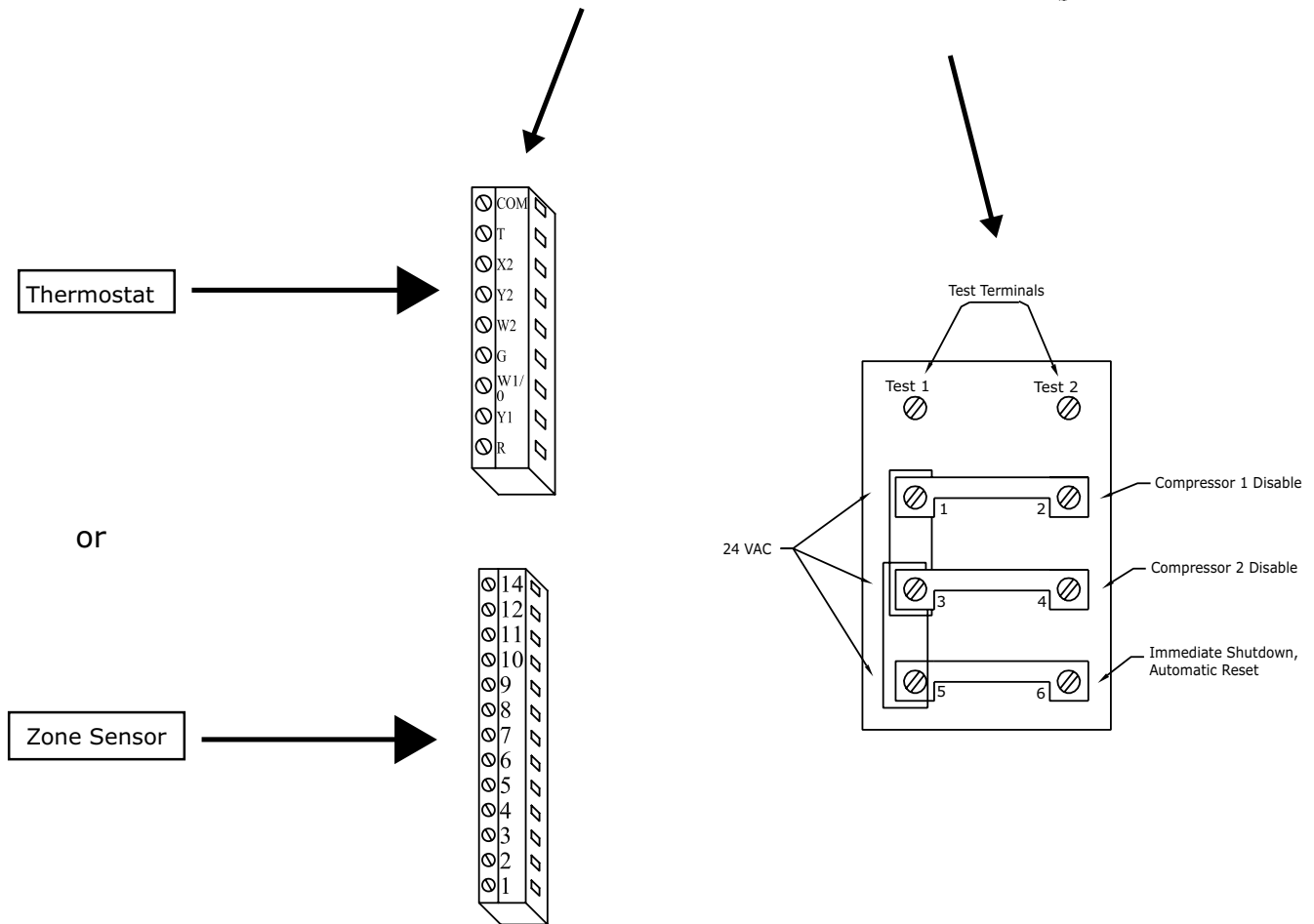
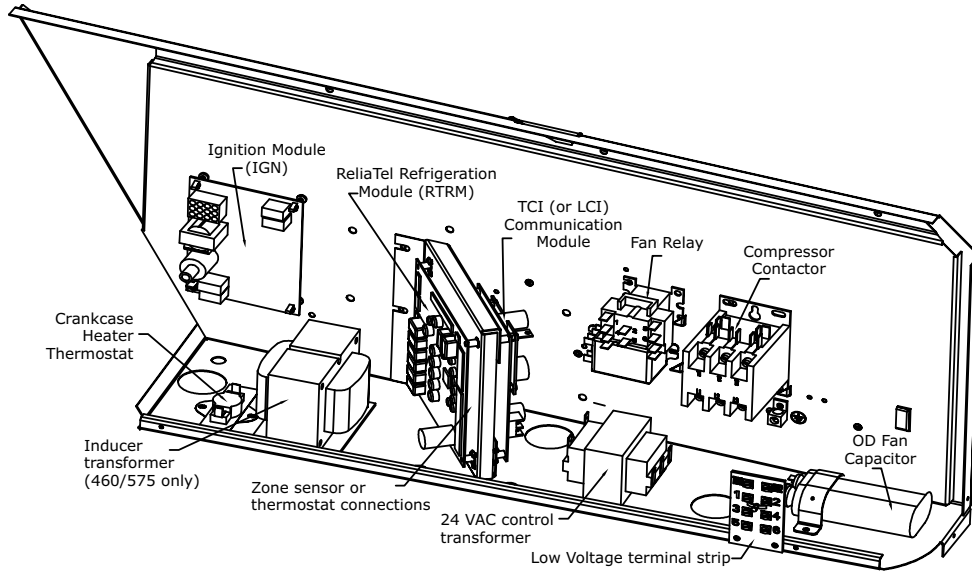

# Typical Control Box Layout

Figure 19. Typical control box layout (T/YSC072-102\*, T/YHC048-072\*, and WSC060-090\*)

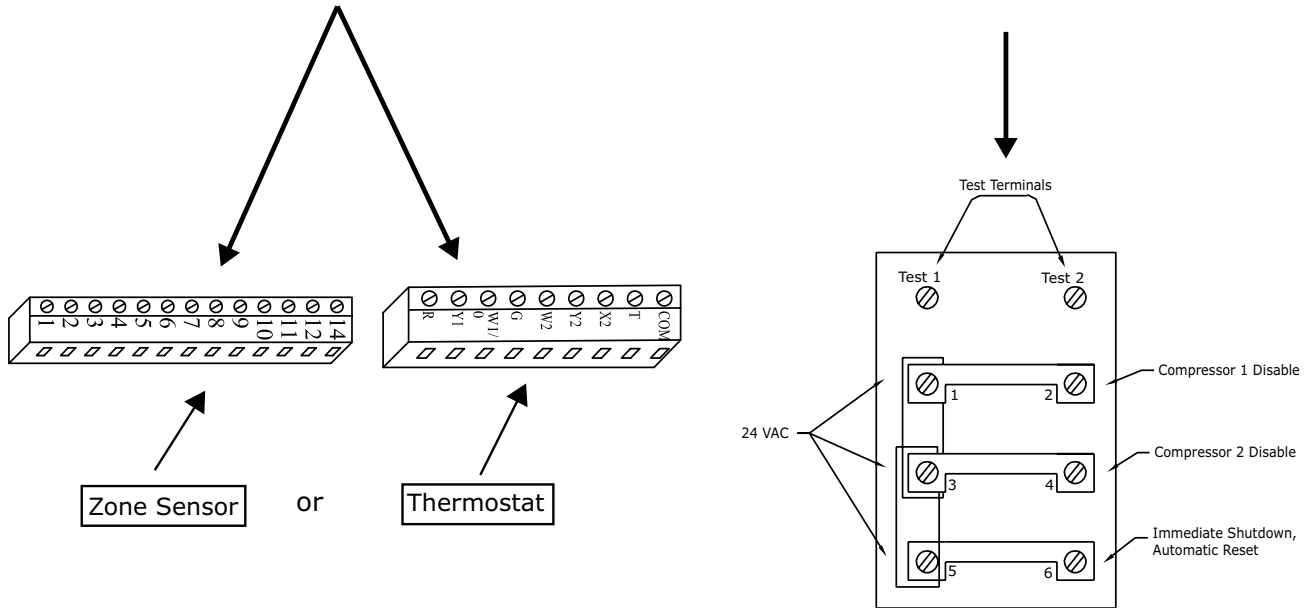
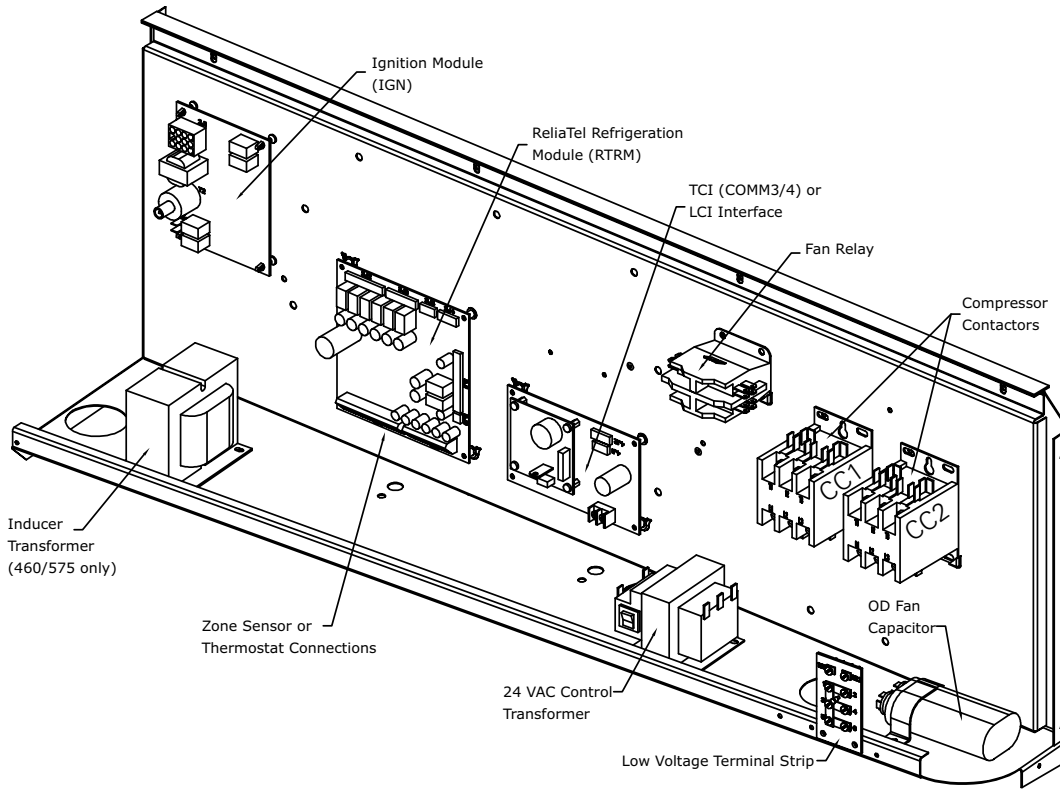
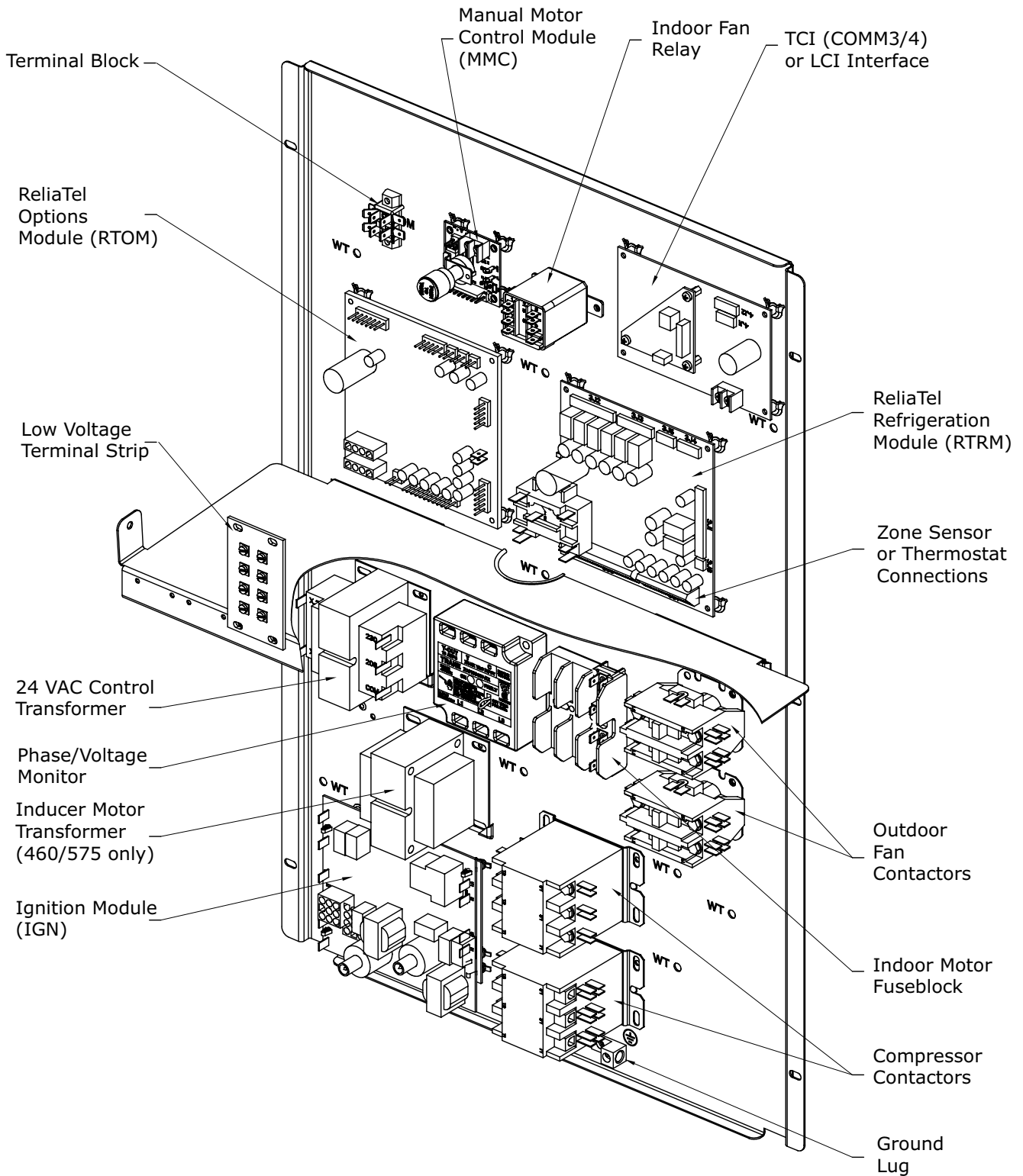



Figure 20. Typical control box layout (T/YSC120\*, T/YHC092-120\*, and WSC120\*)



# Typical Control Box Layout

Figure 21. Typical control box layout (12.5 to 25 tons)

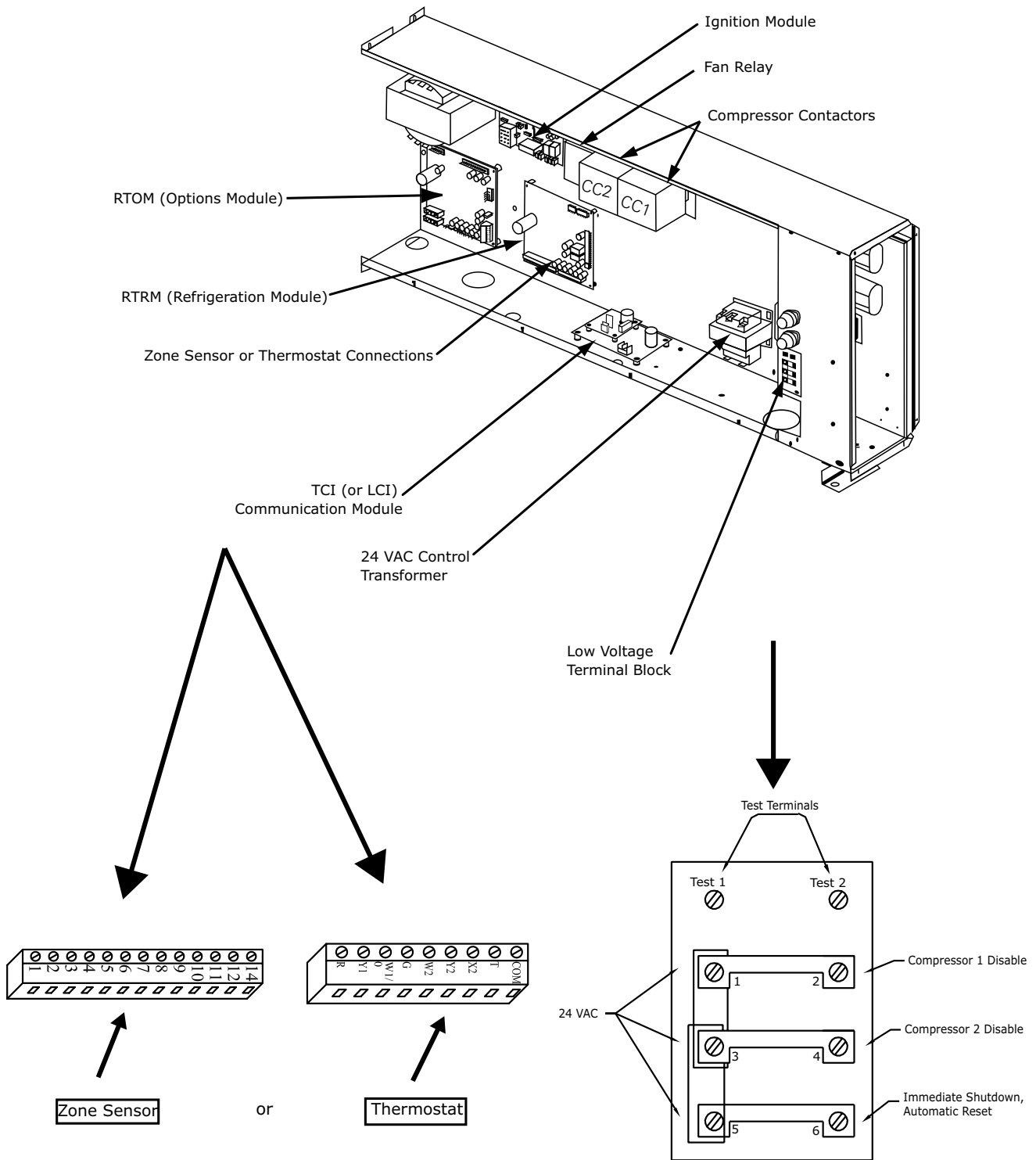
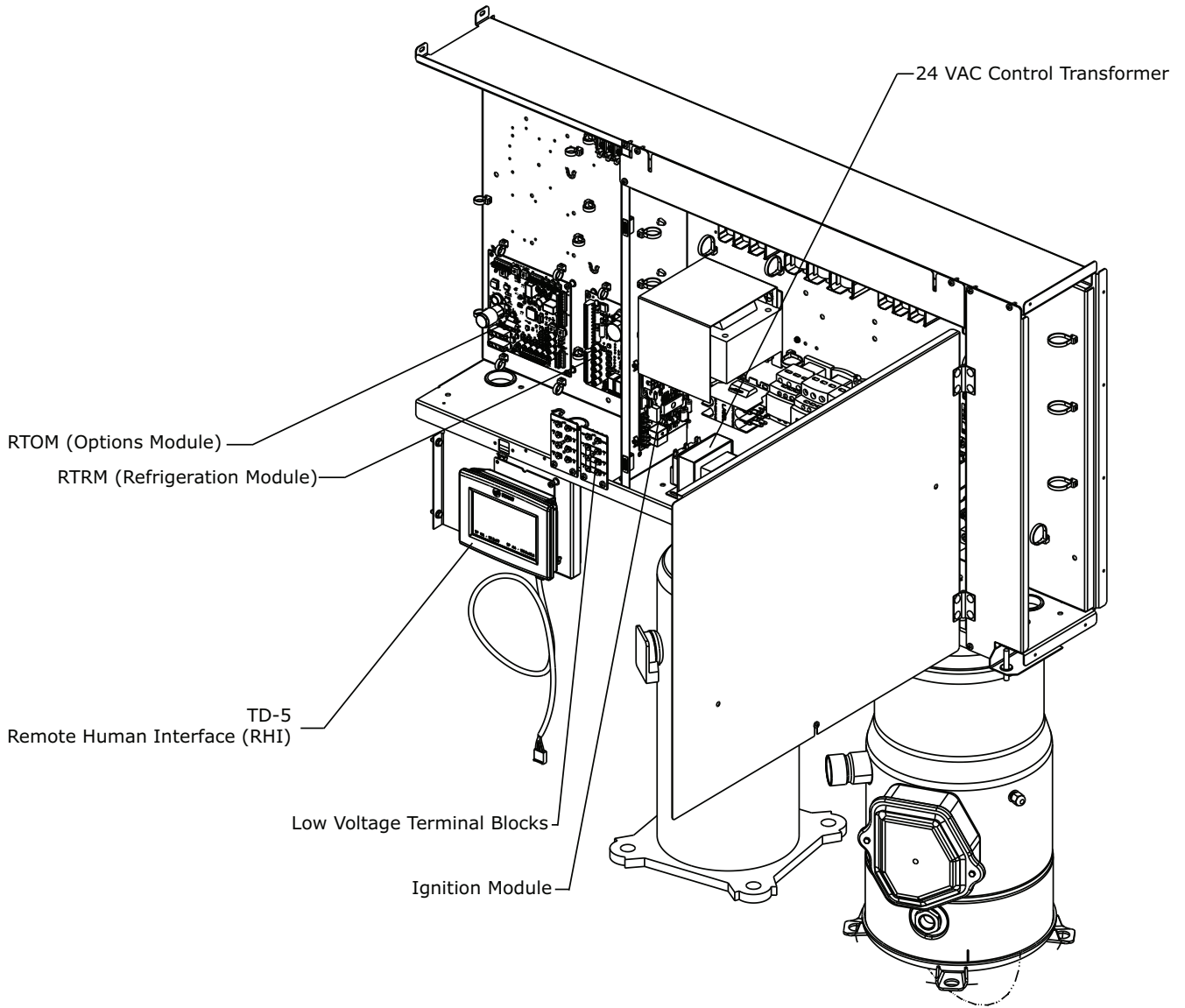
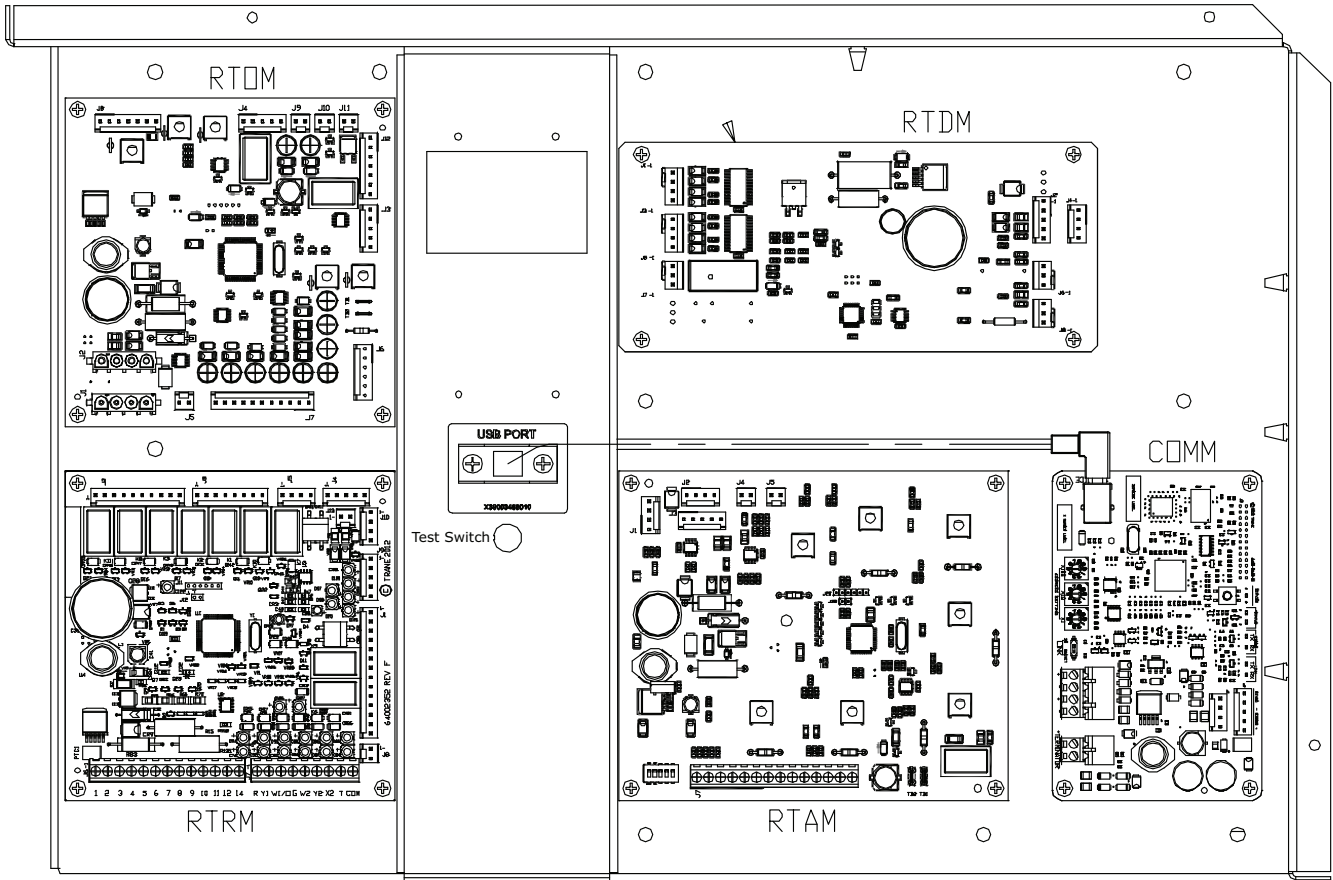

Figure 22. Optional control box layout (12.5 to 25 tons)



# Typical Control Box Layout

Figure 23. Typical control box layout (27.5 to 50 tons)



**Note:** Service Test Switch must be in the "Off" position when power is applied to the unit, else the unit will not go into the Test mode.

# ReliaTel™ Refrigeration Module (RTRM)

Figure 24. ReliaTel Refrigeration Module (RTRM) - layout

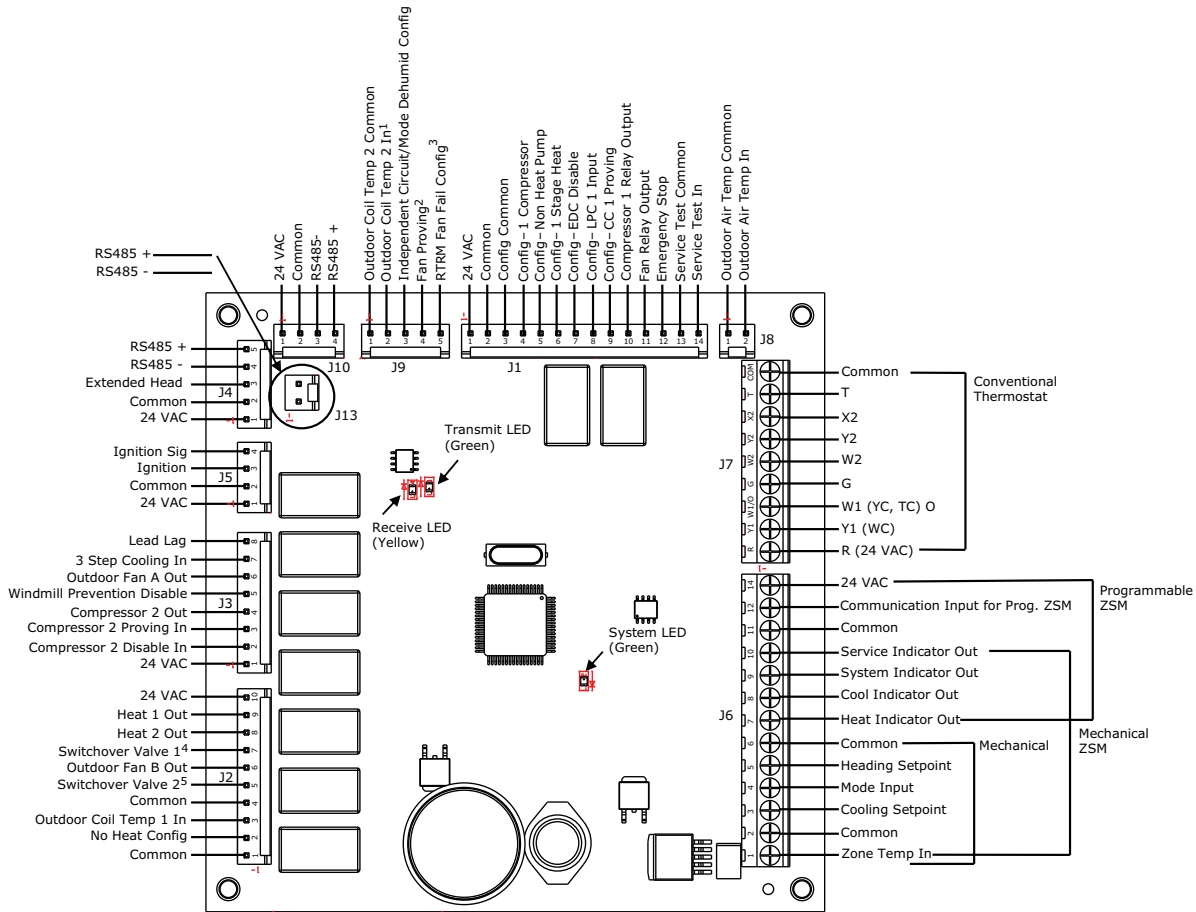

**Notes:**

1. Also used as 2-Speed Indoor Fan config or Condensing Temperature Input on 6-10 ton eFlex™ configurations.
2. Also used for compressor 3 Proving Input on Voyager 3 and 25 ton Voyager 2 units or a configuration input for SZVAV, multispeed, and 2-speed compressor units.
3. Used on SZVAV and Multi-Speed Fan units to configure for Minimum Speed Supply Fan during Economizer Only Operation.
4. Used as compressor 3 out on 4-stage Voyager 2 units.
5. Used as compressor 3 out on 5-stage DX units.

**Figure 25. ReliaTel™ refrigeration module (RTRM)**

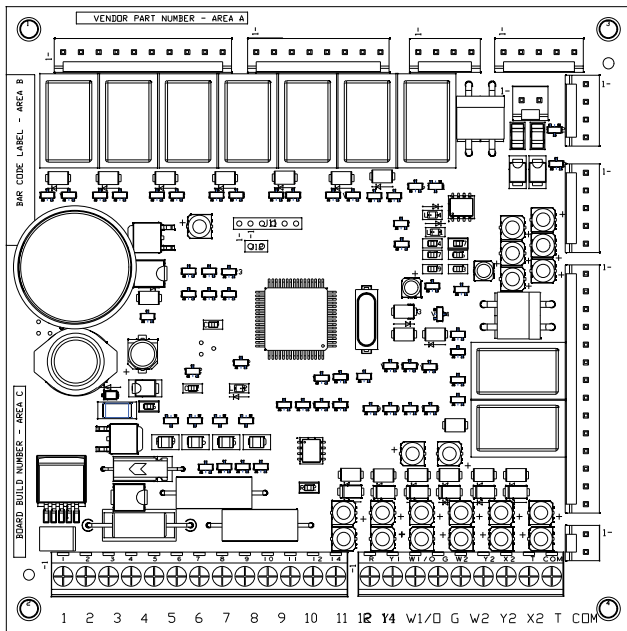

- RTVM communication failure
- Space pressure sensor failure
- Dehumidification mis-configuration
- Reheat circuit entering evaporator temperature failure
- Zone temperature sensor failure during unoccupied mode and on units with modulating reheat (VAV only)
- Duct static pressure transducer output failure (VAV only)
- High duct static pressure trip (VAV only)
- Discharge air sensor failure (VAV only)
- Space pressure transducer failure (Statitrac)
- Outside air flow transducer failure (Traq)

If the service technician sees the RTRM fault indication, the next step is to check for diagnostics as indicated on the following pages to help determine which of the above diagnostics is present.

**Note:** Since constant volume (CV) units (3 to 50 tons) may use a conventional thermostat, the RTRM will not display a diagnostic if a zone sensor is not attached when power is applied to the unit. The RTRM ignores a zone sensor if it is attached to a powered-up unit (after a brief time-out). Always reset power after installing a mechanical ZSM to terminals RTRM J6-1 through J6-10.

## RTRM Diagnostics

**Note:** For production, several versions of the RTRM are used depending on unit functions. There is one replacement module for all units.

### RTRM System LED Diagnostic Indicator

On RTRM version 4.0 or higher, the green system LED on the RTRM module can provide a quick visual indication of the presence of certain diagnostics. If the green LED on the RTRM is blinking with two ¼ second blinks every two seconds, one or more of the following diagnostics is present:

- Supply fan fail
- Zone temperature sensor input failure on CV units
- Programmable ZSM communication failure
- Manual compressor lockout (one or both circuits)
- Outdoor coil temp sensor failure (heat pumps only)
- Defrost fault condition (heat pumps only)
- Gas heat failure
- Discharge air temperature failure on modulating heat and modulating reheat units
- Froststat™ active
- Outdoor air temperature sensor failure
- Smoke detector active
- Entering evaporator temperature failure (on modulating reheat units)
- RTOM communication failure
- RTDM communication failure (on modulating reheat units)

The RTRM provides certain diagnostic information to the end user or service technician depending on the type of controls used. Regardless of controls used however, a service technician with a DC voltmeter can read the diagnostics at the RTRM as shown below.

**Note:** When a voltmeter is first applied, allow 2-3 seconds for the reading to stabilize. The actual readings obtained vary depending on the controls used.

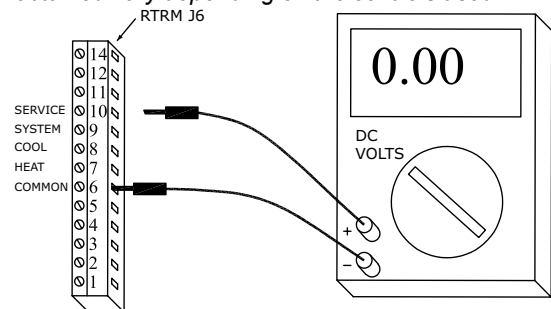

The following charts show what readings to expect, as well as what the readings mean.

**Table 1. Approximate voltage readings (depending on control used)**

| See "What the readings mean" on the following pages | Thermostat or mechanical ZSM without indicators or with no controls attached at all | Programmable ZSM with indicators | Mechanical ZSM with indicators |
|---|---|----------------------------------|--------------------------------|
| ON  | 32 VDC ± 10%  | 26 VDC ± 10%                     | 2.0 VDC ± 10%                  |
| OFF   | 0.75 VDC ± 10%  | 0.75 VDC ± 10%                   | 0.75 VDC ± 10%                 |
| PULSING   | 20 to 30 VDC  | 14 to 30 VDC                     | 1.5 to 2.5 VDC                 |

**Service - RTRM-J6-10**

**What the Readings Mean**

• **ON**

Clogged filter switch has been closed for at least 2 minutes, indicating a clogged filter. This example illustrates what would be seen if the unit did not have a zone sensor with indicator LEDs, such as would be the case with an ICS system. Table 1, p. 35 lists voltages seen if a zone sensor is attached. Volt meter readings should be within 10%.

• **OFF**

- Clogged filter switch is in open position or no switch is installed.
- Fan fail switch (if installed) has opened (3 to 25 tons) or closed (27.5 to 50 tons) within the first 40 seconds, proving that the supply fan has started.

• **PULSING**

- Fan proving switch/fan fail switch (FFS) has failed to open (3 to 25 tons) or close (27.5 to 50 tons) before 40 seconds. During this condition, the unit will run for 40 seconds and then stop. Only the fan will run during the TEST mode, except during the first 40 seconds.
- Condensate pan switch is actively closed or has closed 3 times during a 24 hour period.

**Note:** At the bottom of the meter display, the analog bar will pulse back and forth. Some meters do not have this extra feature.

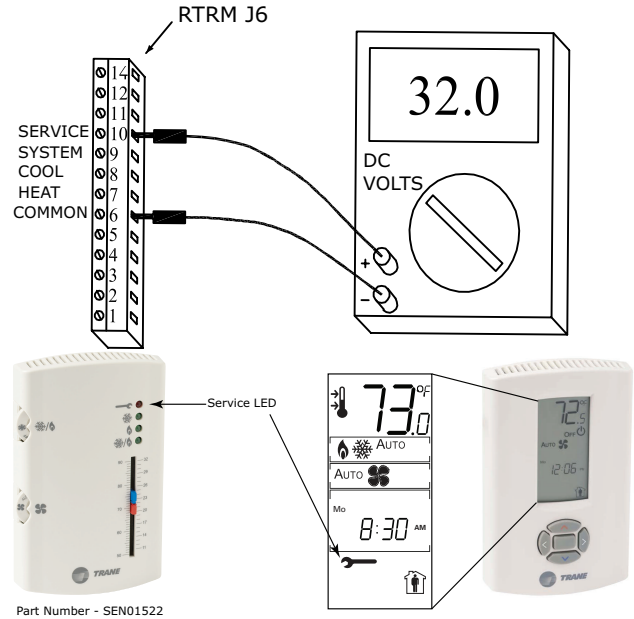

**System- RTRM-J6-9**

**What the Readings Mean**

• **ON**

System is powered up. This output should be on whenever the green RTRM System LED is on. Incidentally, this LED may flicker as part of its normal function on older version boards.

• **OFF**

If 0 Vdc is seen, the RTRM does not have power, the output wiring is shorted, or there is an internal failure. Remove any wires connected to this terminal and check again.

• **PULSING**

Unit is in the TEST mode. Also during the TEST mode the System LED will pulse on and off. This output does not provide any diagnostic information, but is a good place to confirm voltage readings taken are consistent with what should be seen on other outputs.

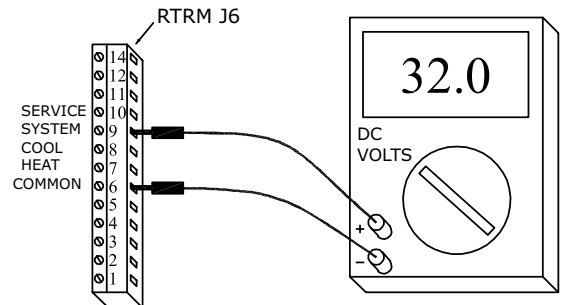

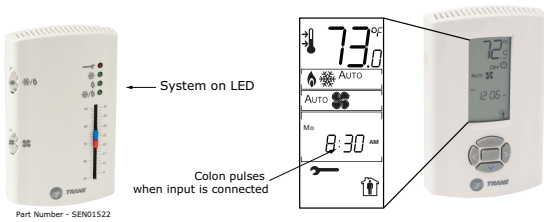

### Cooling-RTRM-J6-8

#### What the readings mean

- **ON**  
System is in the **cooling** mode and actively cooling. The unit could be economizing or have one or both compressors on. If the unit is a heat pump, the reversing valve is energized as well.
- **OFF**  
System is not actively cooling. It may or may not be in the **cooling** mode.
- **PULSING**  
*Note: Any controls.*

This indicator can mean one or more of the following:

- CC1, CC2, or CC3 opens during cooling, or is open when a call for compressor occurs. The unaffected circuit will still run. With RTRM version 4.0 or greater, CC1, CC2, or CC3 circuit must open on 3 consecutive cycles. On the 4th trip, the unit will lockout.
- CPR1 disable or CPR 2 disable input has opened during a compressor cycle each time a compressor starts (within the first 3 minutes) for 3 consecutive cycles. It locks out on the fourth cycle. The unaffected circuit will still run.
- Frostat input is active.

#### Mechanical ZSM

- Zone temperature input failure after a successful input.
- Both heating and cooling setpoint inputs have failed or are not attached (such as when using a two wire sensor on terminals 1 and 2).

#### Programmable ZSM

The ZSM has failed to communicate for 15 consecutive minutes after successful communication has occurred.

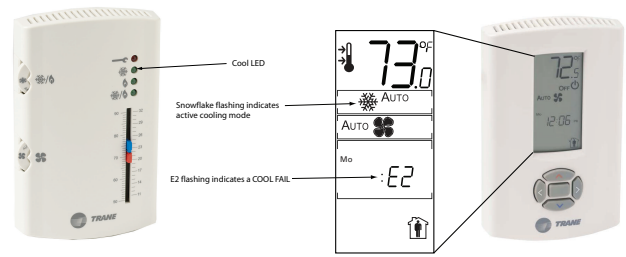
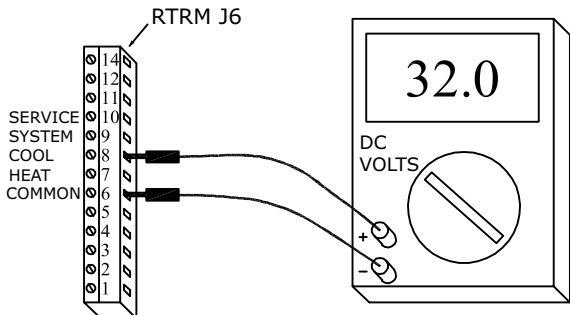

### Heating-RTRM-J6-7

#### What the readings mean

- **ON**  
System is actively heating.
- **OFF**  
System is not actively heating.
- **PULSING**
  - Gas heat: If any failure occurs such as loss of flame, limit switch trip, flame rollout etc, this indication is present. Further diagnostics are available by examining the ignition module LED. See the gas heat section for detail.
  - Electric heat: These units have safety limit switches in the electric heat control circuit. Should a limit switch trip, no diagnostic will occur. the HEAT indication will stay ON.
  - Heat pump: Unit is in the **EMERGENCY HEAT** mode. If the compressor disable circuit or CC1, CC2 circuits create a lockout during **heating** mode, a COOL FAIL (pulsing) indication will occur, not a HEAT FAIL (pulsing) indication. See COOL indications for details.

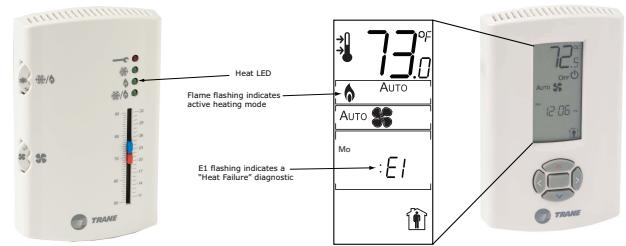
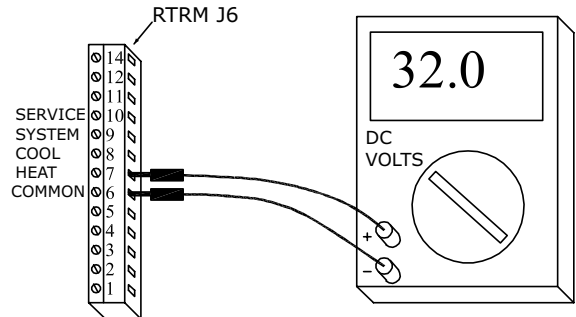



## HEAT FAIL and COOL FAIL at the Same Time, RTRM-J6-7 and 8 Pulsing Voltage

### What the Readings Mean

- Coil temperature sensor is open or shorted (heat pump only).
- Unit has failed to defrost properly (see heat pump section for further details).
- Outdoor air sensor is open or shorted (RTRM version 4.0 or greater).
- Dehumidification unit - RTOM disconnected or not communicating. RTOM will flash once every few seconds.
- Emergency stop input is open (no 2 flash diagnostic present on RTRM).
- Factory installed phase monitor is indicating a fault (no 2 flash diagnostic present on RTRM).
- Entering evaporator temperature failure (on modulating reheat units).
- RTDM communication failure (on modulating reheat units).
- Supply air temperature is invalid and unit is SZVAV, CV with modulating heat or modulating reheat, or supply air tempering is enabled.

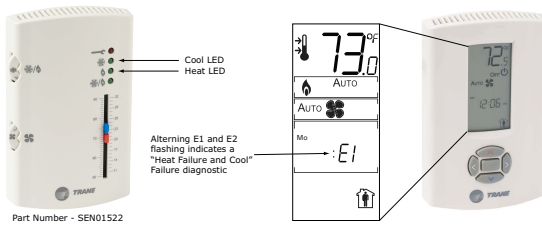

## HEAT + COOL + SERVICE

Smoke Detector failure active.

## Compressor Will Not Run - No Diagnostics

- Froststat™ trip (RTRM v8.0 and later will exhibit diagnostics as described previously).
- Compressor disable input open.
- Unit is economizing, and outside air damper is not yet at 100%.
- Unit is in “heat” mode or “off” mode.
- Tracer® or building management system is preventing compressor operation (demand limit).

## System OFF - No Diagnostic

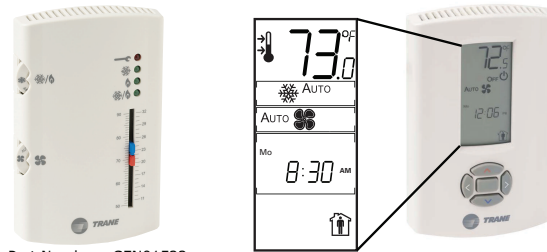

Part Number - SEN01522

Unit is in **OFF** mode locally or through TCI/LCI

## Heat Pump - Compressors Will Not Run

- Unit is in the **EMERGENCY HEAT** mode.
- If the compressor disable circuit or CC1, CC2 circuits create a lockout during **heating** mode, a **COOL FAIL** (pulsing) indication will occur, not a **HEAT FAIL** (pulsing) indication. See **COOL** indications for details.

## MZVAV/VAV unit - Additional Diagnostics

### COOL

Zone temp input (RTRM J6-1) is open, shorted, or failed during an unoccupied mode. If the unit has a default mode input (jumper from RTRM J6-2 to RTRM J6-4, a valid zone temp input is needed for unoccupied heating, MWU and DWU).

### COOL + SERVICE

Static pressure transducer output voltage at RTAM J1-3 is less than 0.25 Vdc. The transducer output is open, shorted, or the transducer is reading a negative supply air pressure.

### HEAT + COOL + SERVICE

- Static pressure high duct static trip. The static pressure has exceeded 3.5 inches wc three consecutive times.
- Ground wire on transducer is open.

## 27.5 to 50 Tons - Additional Diagnostics

If only one diagnostic is present, refer to that diagnostic. If more than one diagnostic is present, refer to combination diagnostics such as **COOL + HEAT** as appropriate. On a BAYSENS020\*, the display will show **HEAT FAIL** or **COOL FAIL** or **SERVICE** (or an appropriate combination) if a diagnostic is present.

### COOL

- Discharge air sensor (DTS) is open, shorted, or has failed.
- CC1 or CC2 24 Vac control circuit has opened three times during a **cooling** mode. Check CC1, CC2 coils or any control in series with the coils (winding thermostat, HPC, circuit breaker auxiliary contacts).
- LPC 1 or LPC 2 has opened during the 3 minute minimum “on” time during 4 consecutive compressor starts. Check LPC 1 circuit by measuring voltage from

## ReliaTel™ Refrigeration Module (RTRM)

RTRM J1-8 to chassis ground. Check LPC 2 circuit by measuring voltage from RTRM J3-2 to chassis ground. If 24 Vac is not present, the circuit is open. 24 Vac should present at these terminals at all times.

- The RTDM Low Pressure Cutout Input (RLP) will be ignored for the first 10 minutes of compressor run time on the reheat circuit. Once active (OPEN), the associated circuit/output will de-energize and not re-energize until the 3 minute off timer is expired and the input has cleared. If the reheat LPC trips 4 times in any mode after the circuit has been energized for 10 minutes, dehumidification will be disabled (all compressors off) and the reheat circuit will be locked out.

### SERVICE

The supply fan proving switch (FFS) has failed to open within 40 seconds after the fan starts or has closed during fan operation.

### HEAT + COOL

- RTDM communication failure.
- Entering air temperature evaporator temperature sensor failure.

### 2 Flash Blink Code - RTRM Only

- Outside Air Flow Transducer (Traq) reading outside of normal operating range or bad calibration solenoid.
- Space Pressure Transducer (Statitrac) reading outside of normal operating range or bad calibration solenoid.

### LonTalk® Communication Interface (LCI)

- When an LCI (LonTalk® Communication Interface) is installed on a Voyager™ Commercial VAV unit, the morning warmup (MWU) setpoint located on the RTAM board is ignored. The morning warmup and daytime warmup setpoints come from the higher priority LCI-R.
- The MWU terminate setpoint is identified as NCI (network configuration Input) nciSetpoints.occupied heat. The default setpoint is 71°F.
- The MWU initiate setpoint is nciSetpoints.occupied heat - 1.5°F.

## BACnet® Operations

**Note:** Reference *BACnet® Integration Guide: BAS-SVP09\*-EN*.

## Default Operations

The ReliaTel™ refrigeration module (RTRM) can accept input from any of the following:

- Mechanical Zone Sensor Module (ZSM) BAYSENS106-111\*, AYSTAT106\*-109\*
- Programmable Zone Sensor BAYSENS119\*, 20\*, AYSTAT666\*

- Conventional thermostat BAYSTAT036-038\* (or similar, ASYSTAT701-703\*)
- ICS systems – Tracer®, Tracker®, VariTrac®

With each installed device, default modes of operation come into play, depending on that device's inputs. The following is a summary of functions and defaults.

**Table 2. Default operation for mechanical ZSM (CV only)**

| J6 input/connection             | if no input/connection this happens  |
|---------------------------------|--|
| J6-1- zone temperature          | Unit stops   |
| J6-2 - common terminal for 1-5  | Unit stops   |
| J6-3 - cooling setpoint (CSP)   | HSP + 3F if local unit mode is Auto, otherwise local HSP                   |
| J6-5*- heating setpoint (HSP)   | Local CSP - 3F if local unit mode is Auto, otherwise, local CSP            |
| J6-3&5 - no CSP or HSP from ZSM | 74F CSP, 71F HSP   |
| J6-4- mode input from ZSM       | Auto changeover with continuous fan  |
| J6-6*- common terminal for 7-10 | LEDs will not function any time  |
| J6-7*- heat indication          | LED will not come on while heating<br>LED will not flash during heat fail  |
| J6-8*-cool indication           | LED will not come on while cooling<br>LED will not flash during cool fail* |
| J6-9*- system indication        | LED will not come on while unit has power                                  |
| J6-10*- service indication      | LED will not come on when CFS or FFS trips                                 |

**Note:** \* these connections are only on certain model ZSMs.

**Table 3. Default operation for programmable ZSM**

| J6 input/connection                         | if no input/connection this happens:  |
|---|---|
| J6-7- heat indication from RTRM to ZSM      | "Heat" will not be displayed while heating<br>"Heat fail" will not be displayed during heat fail                                      |
| J6-8 - cool indication from RTRM to ZSM     | "Cool" will not be displayed while cooling<br>"Cool fail" will not be displayed during cool fail*                                     |
| J6-9 - system indication from RTRM to ZSM   | Colon (:) will not blink during normal operation<br>"Test" will not be displayed during TEST mode                                     |
| J6-10 - service indication from RTRM to ZSM | <b>Service</b> will not be displayed when clogged filter switch has tripped<br><b>Service</b> will not flash when the FFS has tripped |

**Table 3. Default operation for programmable ZSM (continued)**

| J6 input/connection   | if no input/connection this happens:           |
|-----------------------|--|
| J6-11 - common        | No display, no communication                   |
| J6-12 - communication | No communication - <b>Cool fail</b> indication |
| J6-14-24 - VAC power  | No display, no communication                   |

**Note:** Cool fail indication can occur for several reasons. See diagnostic section for more information.

**Note:** Version 1.1 and 1.3 RTRM do not provide heat, cool, service, cool fail, heat fail indications for programmable ZSM. Later versions with a higher number do.

COMM3/4 and COMM5 Communication Interface Module use MODBUS communication directly with the RTRM. Tracker® and Tracer® require inputs as shown:

**Table 4. Default operation for ICS control:**

| J6 input/connection                               | if no input this happens:  |
|---|--|
| J6-1 - zone temperature                           | Unit stops unless Tracer® is providing zone temperature input (CV units)                           |
| J6-2 - common terminal for J6-1, J6-3, J6-4, J6-5 | Unit stops unless Tracer® is providing zone temperature input (CV units) or mode input (VAV units) |
| J6-4 - mode input (VAV units)                     | Unit stops unless Tracer® is providing a mode input  |

**Note:** VariTrac® does not require any input to J6.

**Table 5. Conventional ZSM thermostat default operation**

| Input/connection   | if no input, this happens:                   |
|--|--|
| G (indoor fan)<br>The purpose of G is to provide a way to run the fan continuously | A heat or cool call will also enable the fan |

**Note:** See section on conventional thermostat operation for more information.

**Table 6. 3 to 50 tons VAV units**

| Input/connection (3 to 50 Tons VAV only) | If no input, this happens:   |
|--|--|
| Default mode input jumper J6-2 to J6-4   | Without a mode input, the unit will not run                          |
| Zone temperature input J6-2 to J6-1      | Unoccupied mode (short J6-11 to J6-12)<br>Gives cool fail diagnostic |

## Tracer® TD-5 Display for ReliaTel™ Controller

Figure 26. TD-5 display



Tracer® TD-5 display information:

- The display allows you to view unit alarms, data, and make operational changes on Voyager™ and Precedent™ units with ReliaTel™ control.
- The display is powered by 24 Vac or 24 Vdc and requires 21 VA power.
- The display is connected to J10 on the RTRM module.
- The display is also used as a Fault Detection and Diagnostics (FDD) Display to meet Title 24 requirements for Low Leak Economizers (LLE).
- The display part number is CNT07131.
- See the Tracer® TD-5 Display Installation, Operation, and Maintenance manual for more details - RT-SVX49\*-EN.

# ReliaTel™ Temporary Operation

## 3 to 25 Tons

**Note:** Does not apply to MZVAV.

Temporary comfort can be provided without a zone sensor module or thermostat in place by using the outdoor air sensor or a spare supply air/return air sensor.

1. Remove the sensor from the unit.
2. Add enough thermostat wire to it so that it can be placed in the return air stream.
3. Connect the sensor to J6-1 and J6-2.
4. Power must be cycled to allow unit to see a sensor attached.
5. After the permanent zone sensor or thermostat is in place, the sensor must be removed from J6-1 and J6-2.

## MZVAV

1. Temporary unit operation can be provided by adding a jumper between RTRM J6 – 2 and 4. This puts the unit into occupied cooling mode.
2. Set the supply air cooling setpoint, static pressure setpoint, and static pressure deadband on the RTAM to the desired settings for the application.
3. If heat is required, a zone sensor must be placed on RTRM J6 – 1 and 2.
4. Set the Morning Warm-Up setpoint to the desired terminate temperature and set SW1 - 5 **ON** on the RTAM to enable Daytime Warm-Up.

- Morning Warm-Up will not function in temporary operation as it only initiates on transition from Unoccupied to Occupied, but Daytime Warm-Up will be active with SW1 – 5 **ON** when the zone temp falls 3°F below the Morning Warm-Up setpoint.
- Daytime and Morning Warm-Up both terminate on the Morning Warm-Up setpoint.
- On non-MZVAV units, if the RTRM does not have a space temperature input (J6-1, J6-2), or have a conventional thermostat input (G, Y, W), the unit will not run (except in the test mode).
- On MZVAV units, if the RTRM does not have a mode input (RTRM J6-2, J6-4), the unit will not run (except for test mode).

## Temporary Sensor (Thermistor) Attached to J6-1 and J6-2 Only

**Note:** Does not apply to MZVAV.

- Continuous fan
- Auto changeover
- 74°F cooling, 71°F heating

**Note:** 27.5 to 50 tons - the outdoor air sensor should not be used for this purpose.

# ReliaTel™ Option Module (RTOM)

Figure 27. ReliaTel™ option module (RTOM)

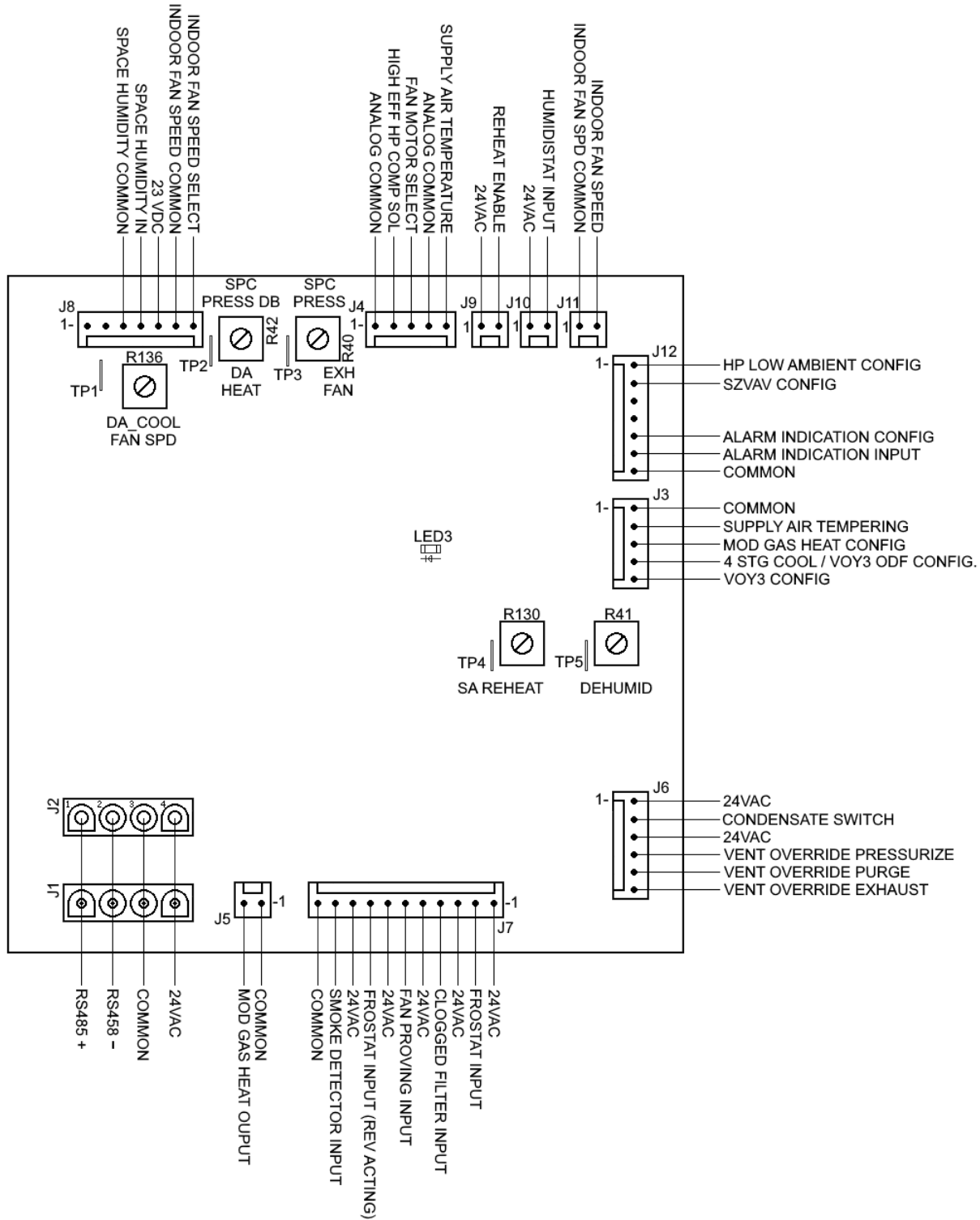

## RTOM Location

### 3 to 10 Tons

The RTOM is installed in the indoor fan section. When field installed, it comes with a short harness which allows both ends of the unit control harness to be attached.

### 12.5 to 50 Tons

The RTOM is installed in the control panel.

## RTOM Inputs

### J1, J2 Inputs

J1 provides 24 Vac power and MODBUS communication to and from the RTRM (via the COMM module if used). J2 sends power and communication to the ECA or RTEM (if used).

### J3 Inputs

- J3-1 to J3-2 – Allows supply air tempering when using a mechanical ZSM. Removed = supply air tempering enabled, installed = disabled. Supply air tempering can also be enabled or disabled by using the BAYSENS119\* or a Trane® ICS system.
- J3-3 is modulating gas heat config. input J3-4 is used with 27.5 to 50 ton units to configure condenser fan control type.
- J3-5 is used to configure the unit as a Voyager™ commercial unit. (27.5 to 50 ton units only).

Input is also used on 25 ton high efficiency Voyager™ light commercial products to indicate 4 stages of cooling are required.

### J4 Output

Precedent™ 6 to 10 tons high efficiency heat pump units utilize a J4 output for compressor staging.

### J4 Input

**Discharge air sensor** (10K @ 77°F/25°C) allows supply air tempering, also discharge air information for Building Automation systems (BAS) using COMM5 such as Tracer® Summit V13 and Tracker® Version 10. Earlier versions of Tracker® (V6.5 and below) and any Tracer® system using COMM3 or COMM4 do not recognize this input.

The input seen by Tracer® (using COMM3 or COMM4) and Tracker® (prior to Version 10) is Supply Air Temperature, which is actually the Mixed Air Temperature input from the ECA or RTEM to the RTRM. The other inputs on J4 are not used.

**PWM motor configuration** J4-1 closed to J4-3 configures the output of RTOM J11 for PWM output.

### J5 Output

J5 is the 2-10 Vdc output used when the unit has modulating gas heat.

### J6 Inputs

**Ventilation override** inputs J6-1, 2, 3 are explained in the “ReliaTel™ Ventilation Override,” p. 162.

### J7 Inputs

#### Frostat™

|                 |                                 |
|-----------------|---------------------------------|
| 3 to 25 tons    | Closes 10F ±2°<br>Opens 50F ±2° |
| 27.5 to 50 tons | Closes 30F ±2°<br>Opens 40F ±2° |

When the Frostat™ opens, the compressors will re-start.

- **Clogged filter switch** is factory set to close at 0.45 in. wc, however is adjustable from 0.05 in. wc to 12.0 in. wc. A 7/32 inch allen wrench is required for this adjustment. When the switch is closed for two minutes, the service indicator on the ZSM will be on (see diagnostics section for details). When the switch opens, the indicator is off (auto reset).
- **Fan proving switch (3 to 25 tons)** is factory set to open at 0.07 in. wc, and is adjustable from 0.05 in. wc to 12.0 in. wc, though adjustment is not recommended. If the switch does not open within 40 seconds after the fan starts, the unit stops, requiring manual reset from the zone sensor or BAS system, or by resetting power to the unit. The SERVICE indicator on the ZSM will pulse during fan fail mode.
- **Fan proving switch (27.5 to 50 tons)** is factory set to close at 0.15 in. wc, and is adjustable from 0.05 in. wc to 12.0 in. wc, though adjustment is not recommended. If the switch does not close within 40 seconds after the fan starts, the unit stops, requiring manual reset from the zone sensor or BAS system, or by resetting power to the unit. The SERVICE indicator on the ZSM will pulse during fan fail mode.
- **Smoke detector** contacts are open during normal operation. When closed, the unit shuts down immediately. When the contacts are opened again, the unit will automatically restart.

**Note:** Ventilation override option will override smoke detector input through the RTOM.

### J8 Input

Discharge Air Cooling Resistor (DACR) for SZVAV use or configuration jumper for multi-speed use. **Relative humidity sensor** provides input to reheat for dehumidification.

**DA Cool setpoint** J8-6 and 7 used for Precedent DA Cool setpoint (WIR09782), formerly used for DA Cool Potentiometer. Not used on Voyager units.

## J9 Input

**Reheat enable input** provides a binary input to configure the unit for reheat.

## J10 Input

**Humidistat** provides binary input to energize the reheat valve for dehumidification. When the humidistat is satisfied, the reheat valve is de-energized (3 to 25 ton units only).

## J11 Output

**Fan control output** for multi-speed and SZVAV.

## J12 Input

**Heat pump low ambient limit config** provides a configuration input to disable compressor heating on heat pumps when the outdoor temperature falls below 1.4°F. Compressor heating is enabled when the outdoor temperature rises to 3.5°F.

**Precedent™ high efficiency heat pumps low ambient limit** provides a configuration input to disable compressor heating on heat pumps when the outdoor temperature falls below 30°F. It is adjustable with a BAS or a TD-5.

**Alarm indication config** provides a configuration input to determine which diagnostics will energize the alarm indication output. If open, the alarm indication output will energize when the RTRM System LED is blinking a 2-blink error code. If closed to common, the alarm indication output will energize when any key system component is locked out (Cooling, Heating, etc.).

**Alarm indication output** provides a 24 Vac output when the system is in an alarm condition as determined by the alarm indication config.

## Setpoint Potentiometers

**Exhaust setpoint potentiometer** sets the point when exhaust fan will come on. It can be set from 0% (exhaust is always on unless overridden off) to 100% (exhaust fan comes on when economizer is 100% outside air). Turn clockwise to increase setpoint.

**Discharge air heat setpoint potentiometer** sets the discharge air setpoint on units configured with modulating gas heat under thermostat control.

**SA reheat setpoint potentiometer** - For 27.5 to 50 ton Voyager™ commercial units, used to set the Supply Air Reheat setpoint for units with modulating dehumidification.

**Dehumidification setpoint** - For units with reheat (on/off and modulating) installed, used to set the space humidity setpoint used for dehumidification control.

**DA COOL-FAN SPD** potentiometer sets the fan speed on some Precedent™ and Odyssey™ products. It also sets the discharge air cooling setpoint limit on Voyager™ units.

**Note:** For RTOM v3.0 and later, test point hooks are included on the module next to each setpoint potentiometer to allow a more accurate setup. Connect a DC voltmeter to the test point and ground to verify the setpoint desired according to the tables below:

**Table 7. RTOM discharge air heat setpoint**

| Voltage (VDC) | Setpoint (°F) |
|---------------|---------------|
| 0             | 50            |
| 0.09          | 51            |
| 0.13          | 52            |
| 0.16          | 53            |
| 0.2           | 54            |
| 0.24          | 55            |
| 0.28          | 56            |
| 0.31          | 57            |
| 0.35          | 58            |
| 0.42          | 60            |
| 0.46          | 61            |
| 0.5           | 62            |
| 0.53          | 63            |
| 0.57          | 64            |
| 0.61          | 65            |
| 0.65          | 66            |
| 0.68          | 67            |
| 0.72          | 68            |
| 0.76          | 69            |
| 0.79          | 70            |
| 0.83          | 71            |
| 0.87          | 72            |
| 0.9           | 73            |
| 0.94          | 74            |
| 0.98          | 75            |
| 1.00          | 76            |
| 1.03          | 77            |
| 1.06          | 78            |
| 1.08          | 79            |
| 1.11          | 80            |
| 1.13          | 81            |
| 1.16          | 82            |
| 1.18          | 83            |
| 1.21          | 84            |
| 1.23          | 85            |
| 1.26          | 86            |
| 1.28          | 87            |
| 1.31          | 88            |
| 1.33          | 89            |
| 1.36          | 90            |
| 1.38          | 91            |
| 1.41          | 92            |
| 1.43          | 93            |
| 1.46          | 94            |
| 1.48          | 95            |
| 1.51          | 96            |
| 1.53          | 97            |
| 1.56          | 98            |
| 1.58          | 99            |
| 1.61          | 100           |
| 1.63          | 101           |
| 1.66          | 102           |
| 1.69          | 103           |
| 1.71          | 104           |
| 1.72          | 105           |
| 1.74          | 106           |

Table 7. RTOM discharge air heat setpoint (continued)

| Voltage (VDC) | Setpoint (°F) |
|---------------|---------------|
| 1.76          | 107           |
| 1.78          | 108           |
| 1.79          | 109           |
| 1.81          | 110           |
| 1.83          | 111           |
| 1.84          | 112           |
| 1.86          | 113           |
| 1.88          | 114           |
| 1.89          | 115           |
| 1.91          | 116           |
| 1.93          | 117           |
| 1.95          | 118           |
| 1.96          | 119           |
| 1.98          | 120           |
| 2             | 121           |
| 2.01          | 122           |
| 2.03          | 123           |
| 2.05          | 124           |
| 2.06          | 125           |
| 2.08          | 126           |
| 2.09          | 127           |
| 2.11          | 128           |
| 2.12          | 129           |
| 2.13          | 130           |
| 2.13          | 131           |
| 2.14          | 132           |
| 2.16          | 133           |
| 2.17          | 134           |
| 2.19          | 135           |
| 2.2           | 136           |
| 2.21          | 137           |
| 2.23          | 138           |
| 2.24          | 139           |
| 2.25          | 140           |
| 2.26          | 141           |
| 2.28          | 142           |
| 2.29          | 143           |
| 2.3           | 144           |
| 2.32          | 145           |
| 2.33          | 146           |
| 2.34          | 147           |
| 2.36          | 148           |
| 2.37          | 149           |
| 2.4           | 150           |

Table 8. RTOM supply air reheat setpoint (continued)

| Voltage (VDC) | Setpoint (°F) |
|---------------|---------------|
| 1.525         | 72            |
| 1.61          | 72.5          |
| 1.683         | 73            |
| 1.766         | 73.5          |
| 1.822         | 74            |
| 1.887         | 74.5          |
| 1.94          | 75            |
| 1.998         | 75.5          |
| 2.064         | 76            |
| 2.118         | 76.5          |
| 2.175         | 77            |
| 2.196         | 77.5          |
| 2.234         | 78            |
| 2.275         | 78.5          |
| 2.318         | 79            |
| 2.368         | 79.5          |
| 2.415         | 80            |

Table 9. RTOM dehumidification setpoint

| Voltage (VDC) | Setpoint (%) |
|---------------|--------------|
| 0.002         | 40           |
| 0.238         | 41           |
| 0.445         | 42           |
| 0.539         | 43           |
| 0.677         | 44           |
| 0.811         | 45           |
| 0.984         | 46           |
| 1.117         | 47           |
| 1.245         | 48           |
| 1.349         | 49           |
| 1.428         | 50           |
| 1.552         | 51           |
| 1.625         | 52           |
| 1.745         | 53           |
| 1.824         | 54           |
| 1.853         | 55           |
| 1.929         | 56           |
| 1.978         | 57           |
| 2.07          | 58           |
| 2.136         | 59           |
| 2.184         | 60           |
| 2.259         | 61           |
| 2.268         | 62           |
| 2.324         | 63           |
| 2.397         | 64           |

Table 8. RTOM supply air reheat setpoint

| Voltage (VDC) | Setpoint (°F) |
|---------------|---------------|
| 0.002         | 65            |
| 0.169         | 65.5          |
| 0.317         | 66            |
| 0.395         | 66.5          |
| 0.552         | 67            |
| 0.672         | 67.5          |
| 0.785         | 68            |
| 0.915         | 68.5          |
| 1.028         | 69            |
| 1.114         | 69.5          |
| 1.206         | 70            |
| 1.275         | 70.5          |
| 1.365         | 71            |
| 1.445         | 71.5          |

## Discharge Air (DA) Cooling - Setpoint Lower Limit

### Voyager™ Light Commercial

eFlex™ units will utilize a discharge air cool limit potentiometer located on the RTOM (R-136).

**Note:** This is not a DA setpoint, but a DA setpoint lower limit.

Adjust the limit potentiometer by measuring the R-136 potentiometer test point loop to ground and comparing it to the following chart.

**Note:** 50° to 55°F for most applications.



Table 10. Voyager™ DA cool limit temp/voltage

| °F | VDC  |
|----|------|
| 40 | 0.1  |
| 41 | 0.2  |
| 42 | 0.3  |
| 43 | 0.4  |
| 44 | 0.55 |
| 45 | 0.7  |
| 46 | 0.8  |
| 47 | 0.95 |
| 48 | 1.05 |
| 49 | 1.15 |
| 50 | 1.25 |
| 51 | 1.3  |
| 52 | 1.35 |
| 53 | 1.45 |
| 54 | 1.55 |
| 55 | 1.65 |
| 56 | 1.7  |
| 57 | 1.75 |
| 58 | 1.83 |
| 59 | 1.9  |
| 60 | 1.95 |
| 61 | 2    |
| 62 | 2.05 |
| 63 | 2.1  |
| 64 | 2.13 |
| 65 | 2.17 |
| 66 | 2.21 |

**Precedent™**

Table 11. Precedent™ DA cool limit temp/voltage

| °F | VDC  |
|----|------|
| 40 | 0.1  |
| 41 | 0.2  |
| 42 | 0.3  |
| 43 | 0.4  |
| 44 | 0.55 |
| 45 | 0.7  |
| 46 | 0.8  |
| 47 | 0.95 |
| 48 | 1.05 |
| 49 | 1.15 |
| 50 | 1.25 |
| 51 | 1.3  |
| 52 | 1.35 |
| 53 | 1.45 |
| 54 | 1.55 |
| 55 | 1.65 |
| 56 | 1.7  |
| 57 | 1.75 |
| 58 | 1.83 |
| 59 | 1.9  |
| 60 | 1.95 |
| 61 | 2    |
| 62 | 2.05 |
| 63 | 2.1  |
| 64 | 2.13 |
| 65 | 2.17 |
| 66 | 2.21 |

Figure 28. DC volts measured from TP to GND

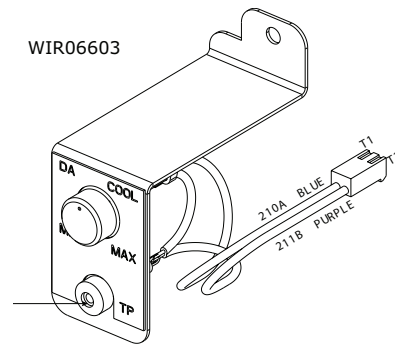

**Note:** Newer units use a DA cooling setpoint resistor (3.3k ohms) jumper harness part number WIR09782. The DA cooling setpoint resistor jumper harness sets the DA cooling setpoint to 50°F.

Figure 29. DACR resistor

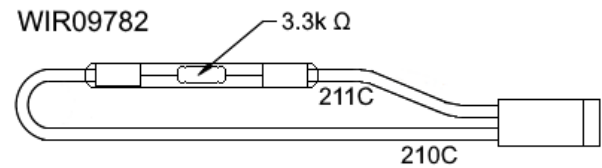

**Odyssey™**

Figure 30. Odyssey™ DA cooling setpoint lower limit

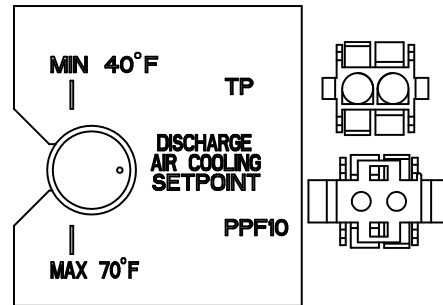

Table 12. Odyssey™ DA cool setpoint (mounted above keyboard)

| °F | VDC  |
|----|------|
| 40 | <0.1 |
| 41 | 0.2  |
| 42 | 0.3  |
| 43 | 0.45 |
| 44 | 0.55 |
| 45 | 0.7  |
| 46 | 0.8  |
| 47 | 0.95 |
| 48 | 1.05 |
| 49 | 1.15 |
| 50 | 1.25 |
| 51 | 1.3  |
| 52 | 1.35 |
| 53 | 1.45 |
| 54 | 1.55 |

**Table 12. Odyssey™ DA cool setpoint (mounted above keyboard) (continued)**

| °F | VDC  |
|----|------|
| 55 | 1.65 |
| 56 | 1.7  |
| 57 | 1.75 |
| 58 | 1.83 |
| 59 | 1.9  |
| 60 | 1.95 |
| 61 | 2    |
| 62 | 2.05 |
| 63 | 2.1  |
| 64 | 2.13 |

**Table 12. Odyssey™ DA cool setpoint (mounted above keyboard) (continued)**

| °F | VDC   |
|----|-------|
| 65 | 2.17  |
| 66 | 2.21  |
| 67 | 2.27  |
| 68 | 2.3   |
| 69 | 2.35  |
| 70 | >2.40 |

**Note:** The potentiometer voltage readings can be verified via the provided test points located next to each potentiometer. Use a DC voltmeter to the Vdc reading between those points and common.

# ReliaTel™ Ventilation Module (RTVM)

Figure 31. ReliaTel™ ventilation module (RTVM) - 3 to 50 tons

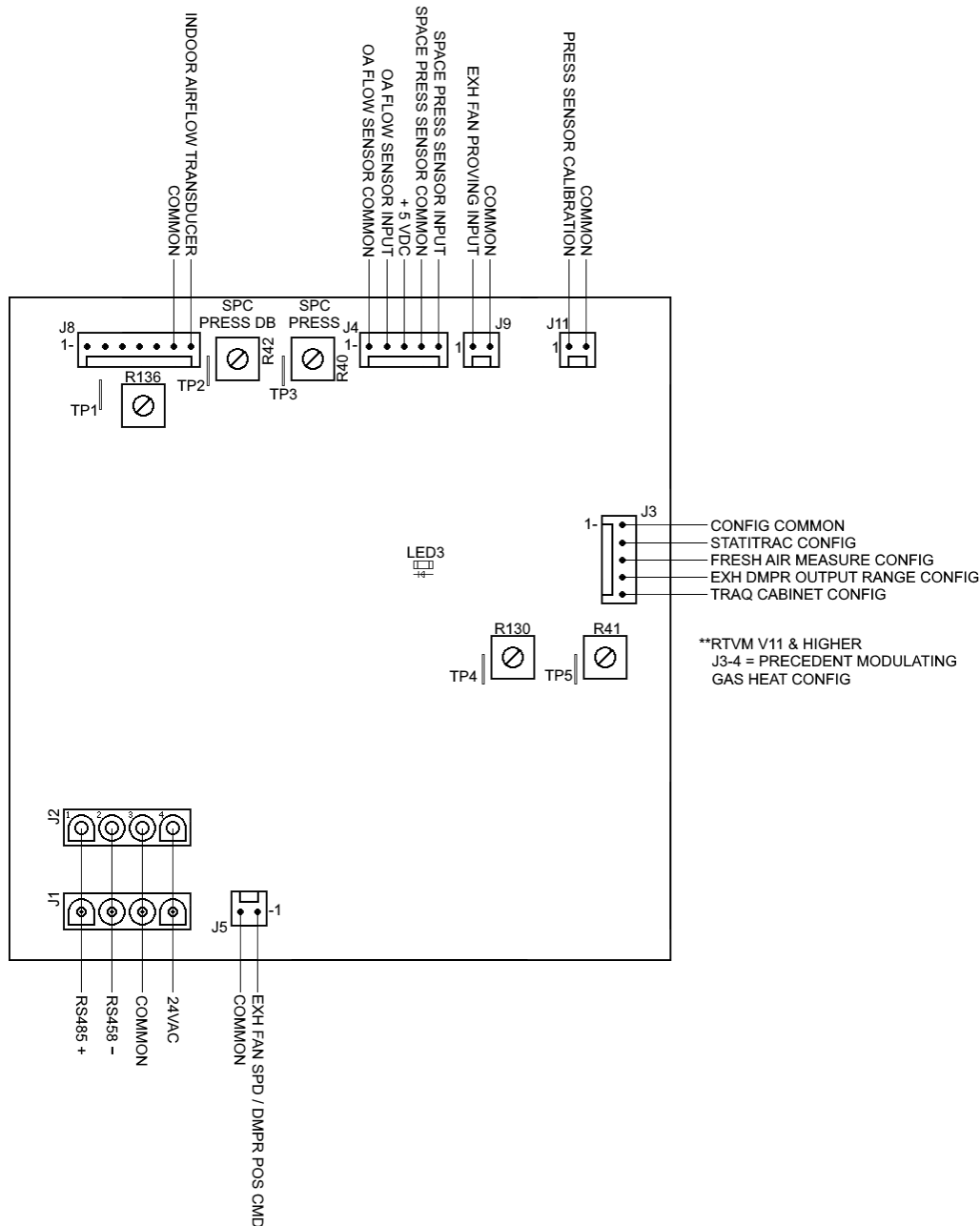

The light commercial RTVM is used with 17 Plus, multispeed, and SZVAV evaporator fan units with demand controlled ventilation (DCV/CO<sub>2</sub>) and Precedent™ units with modulating gas heat.

- BAYRTVM001\* KIT for Voyager™ 12.5 to 25 tons
- BAYCO2K101\* / ASYSTAT721\* 17 Plus, multi-speed and SZVAV Precedent™ (wall mount)
- BAYCO2K103\* / ASYSTAT721\* 17 Plus, multi-speed and SZVAV Precedent™ (duct mount)

## RTVM Location - 3 to 25 Tons

The RTVM can be installed in the control box, indoor blower, or return air sections for Precedent™ and Voyager™ Light Commercial units.

## RTVM Location - 27.5 to 50 Tons

The RTVM is installed in the economizer section for Voyager™ Commercial units with Statitrac™.

## Light Commercial RTVM Inputs

### J1, J2 Inputs

J1 provides 24 Vac power and MODBUS communication to the RTVM from the RTRM.

J2 provides 24 Vac power and MODBUS communication from the RTVM to other optional circuit boards.

## RTVM Inputs

### J1, J2 Inputs

J1 provides 24 Vac power in to the board and MODBUS communication to and from the RTRM.

J2 provides 24 Vac power and MODBUS communication downstream to the ECA or RTEM.

### J3 Inputs

J3 - 1, 2 inputs allow configuration for Statitrac™ control. If closed, the unit is configured for Statitrac™ control.

**Note:** *Precedent™ eFlex™ units with modulating gas heat use the RTVM for additional hardware. The J3-1 and 4 inputs are closed to configure the RTVM for mod gas usage.*

### J4 Inputs

J4 - 3, 4, 5 provide 5 Vdc to the space pressure transducer, an input for the space pressure signal to the control board, and a common for the transducer.

**Note:** *Precedent eFlex™ units with modulating gas heat use the J4-3 input for an airflow monitoring transducer (AFT) for the heat exchanger.*

### J5 Output

J5 - 1, 2 provides a 2-10 Vdc output signal and common to the exhaust damper actuator.

### J11 Output

J11 - 1, 2 provides a 23 Vdc output and common for space pressure transducer calibration. This output is energized once every 60 seconds.

## Setpoint Potentiometers

**Space Pressure Setpoint (R40)** potentiometer provides a space pressure setpoint for Statitrac™ control. The range is -0.20 in. wc to 0.30 in. wc. Default is 0.08 in. wc.

**Space Pressure Setpoint Deadband (R42)** potentiometer provides a selectable deadband for the space pressure setpoint control. The range is 0.02 in. wc to 0.20 in. wc. Default is 0.04 in. wc.

**DCV Minimum Position @ Minimum Fan Speed (R41)** potentiometer provides the DCV minimum economizer outside air damper position for all speeds. The range is 0 to 100%. Default shipping position is 50%.

**Design Minimum Position @ Minimum Fan Speed (R130)** potentiometer provides the design minimum economizer outside air damper position for low speed indoor fan. The range is 0 to 100%. Default shipping position is 50%.

**Design Minimum Position @ Mid Fan Speed (R136)** potentiometer provides the DCV minimum economizer damper position for all speeds. The range is 0 to 75%. Default shipping position is 37.5%.

For RTVM v3.0 and later, test point hooks are included on the module next to each setpoint potentiometer to allow a more accurate setup. Connect a DC voltmeter to the test point and ground to verify the desired setpoint according to the tables below:

**Table 13. RTVM space pressure setpoint (R40)**

| Voltage (VDC) | Setpoint (IWC) |
|---------------|----------------|
| 0.04          | -0.2           |
| 0.118         | -0.19          |
| 0.196         | -0.18          |
| 0.274         | -0.17          |
| 0.352         | -0.16          |
| 0.43          | -0.15          |
| 0.508         | -0.14          |
| 0.586         | -0.13          |
| 0.664         | -0.12          |
| 0.742         | -0.11          |
| 0.82          | -0.1           |
| 0.898         | -0.09          |
| 0.976         | -0.08          |
| 1.02          | -0.07          |
| 1.08          | -0.06          |
| 1.129         | -0.05          |
| 1.178         | -0.04          |
| 1.227         | -0.03          |
| 1.276         | -0.02          |
| 1.325         | -0.01          |
| 1.374         | 0              |
| 1.423         | 0.01           |
| 1.472         | 0.02           |
| 1.521         | 0.03           |
| 1.57          | 0.04           |
| 1.619         | 0.05           |
| 1.668         | 0.06           |
| 1.72          | 0.07           |
| 1.759         | 0.08           |
| 1.798         | 0.09           |
| 1.82          | 0.1            |
| 1.8565        | 0.11           |
| 1.893         | 0.12           |
| 1.9295        | 0.13           |
| 1.966         | 0.14           |
| 2.0025        | 0.15           |
| 2.039         | 0.16           |
| 2.0755        | 0.17           |
| 2.112         | 0.18           |
| 2.1485        | 0.19           |
| 2.15          | 0.2            |
| 2.17          | 0.21           |
| 2.19          | 0.22           |
| 2.22          | 0.23           |
| 2.25          | 0.24           |
| 2.275         | 0.25           |

**Table 13. RTVM space pressure setpoint (R40) (continued)**

| Voltage (VDC) | Setpoint (IWC) |
|---------------|----------------|
| 2.3           | 0.26           |
| 2.325         | 0.27           |
| 2.35          | 0.28           |
| 2.375         | 0.29           |
| 2.42          | 0.3            |

**Table 14. RTVM space pressure setpoint deadband (R42)**

| Voltage (VDC) | Setpoint (IWC) |
|---------------|----------------|
| <b>0.2</b>    | <b>0.02</b>    |
| 0.35          | 0.03           |
| 0.53          | 0.04           |
| 0.71          | 0.05           |
| 0.91          | 0.06           |
| 1.1           | 0.07           |
| 1.235         | 0.08           |
| 1.37          | 0.09           |
| 1.505         | 0.1            |
| 1.65          | 0.11           |
| 1.75          | 0.12           |
| 1.85          | 0.13           |
| 1.95          | 0.14           |
| 2.05          | 0.15           |
| 2.13          | 0.16           |
| 2.21          | 0.17           |
| 2.28          | 0.18           |

**Table 14. RTVM space pressure setpoint deadband (R42) (continued)**

| Voltage (VDC) | Setpoint (IWC) |
|---------------|----------------|
| <b>0.2</b>    | <b>0.02</b>    |
| 2.35          | 0.19           |
| 2.42          | 0.2            |

## Pressure Transducer – Statitrac

**Figure 32. Statitrac™ transducer voltage output vs. pressure - RTVM - 27.5 to 50 tons**

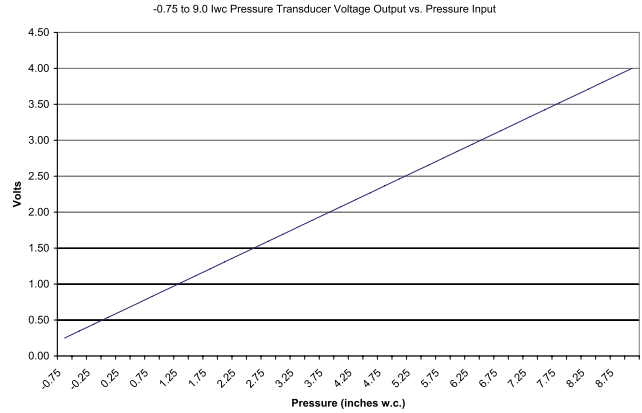

# ReliaTel™ Air Module (RTAM)

Figure 33. ReliaTel™ air module (RTAM)

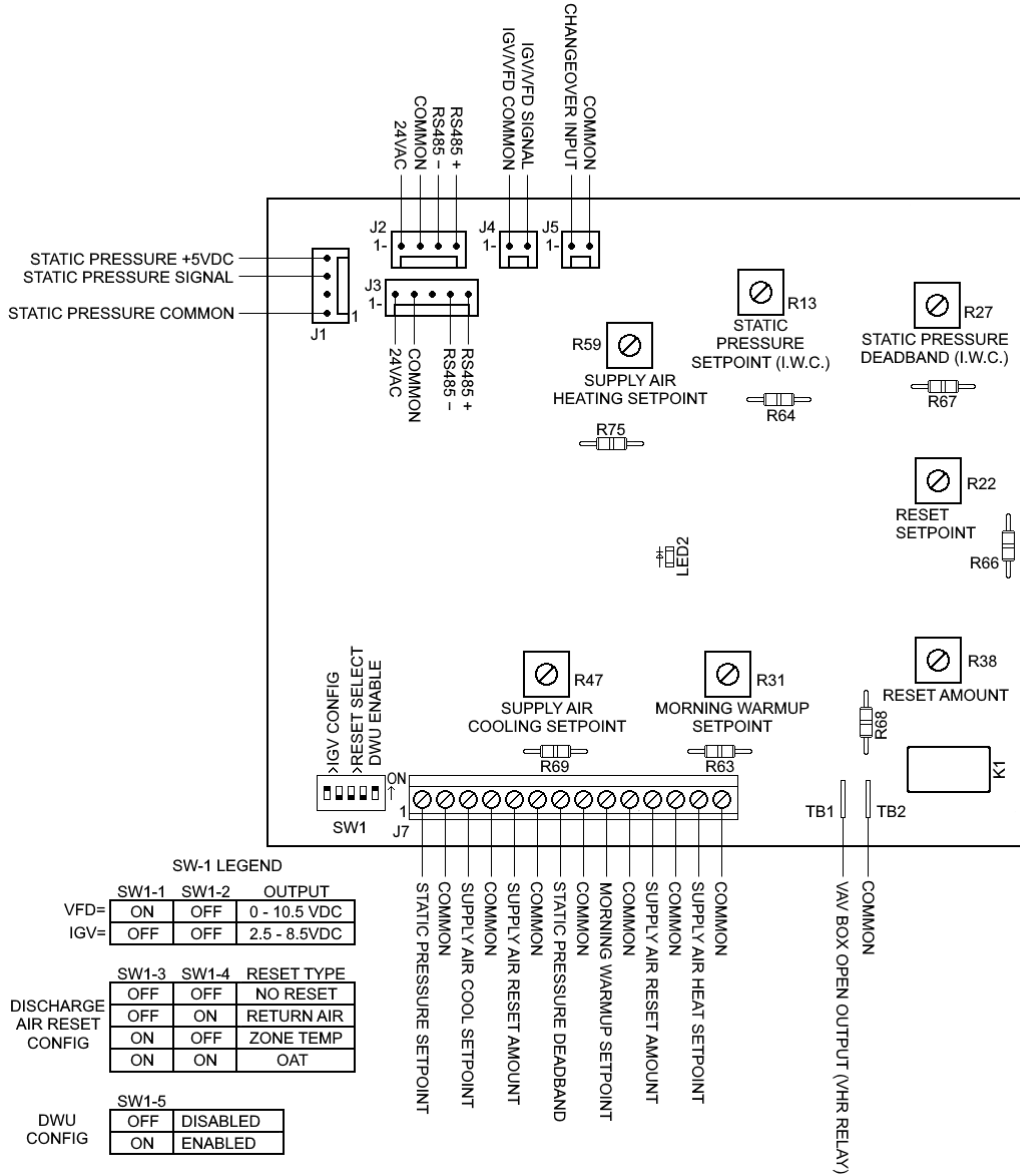

## RTAM Inputs/Outputs

### J1 Input

J1 – 1, 3, 4 provide signal common, input and +5 Vdc for a duct static pressure transducer. (See “Constant Volume (CV) and Variable Air Volume (VAV),” p. 183 for troubleshooting)

### J2, J3 MBUS

J2 provides 24 Vac power and MODBUS communication to and from the RTRM (via the COMM module if used). J3 sends power and communication to the RTOM (if used).

### J4 Output

J4 provides fan speed output on 27.5 to 50 tons Voyager III Commercial VAV units.

## J5 Input

J5 provides a changeover input to switch MZVAV unit from discharge air cooling to discharge air heating on units equipped with modulating gas heat. (LTB-20, 21).

## J7 Input

J7 provides remote hardwired connections for:

- Supply Air Pressure Setpoint
- Supply Air Cooling Setpoint
- Supply Air Reset Amount
- Supply Air Pressure Deadband
- Morning Warm-Up Setpoint
- Supply Air Reset Setpoint
- Supply Air Heating Setpoint

See “Constant Volume (CV) and Variable Air Volume (VAV),” p. 183 for resistance values, requires cutting applicable resistors.

## TB – 1, TB – 2 Output

TB – 1, 2 provide 24 Vac output for VAV box drive open command. (VHR Relay, LTb-15, 16, 17)

## Potentiometer R13 Input Static Pressure Setpoint

R13 sets the local static pressure setpoint, valid range = 0 - 2.5 in. wc.

## Potentiometer R22 Input Reset Setpoint

R22 sets the reset setpoint.

- Zone/Return temp. reset range = 50° - 90°F
- Outdoor air temp. reset range = 0° - 100°F

## Potentiometer R27 Input Static Pressure Deadband

R27 sets the static pressure deadband, valid range = 0 – 1.0 in. wc.

## Potentiometer R31 Input Morning Warm-Up Setpoint

R31 sets the morning warm-up setpoint.

Morning warm-up initiates when zone temperature is 1.5°F less than the MWU setpoint ( $ZT = MWU\ SP - 1.5^\circ F$ ).

Daytime warm-up (SW1-5 = ON) initiates when the zone temperature is 3°F less than the MWU setpoint ( $ZT = MWU\ SP - 3^\circ F$ ). Both daytime and morning warm-up terminate on the morning warm-up setpoint (R31).

Valid range = 50° - 90°F

## Potentiometer R38 Input Reset Amount

R38 sets the reset amount. The reset amount is applied to the supply air cooling setpoint while reset conditions are active.

Valid range = 0° - 20°F

## Potentiometer R47 Input Supply Air Cooling Setpoint

R47 sets supply air cooling setpoint.

Valid range = 40° - 80°F

## Potentiometer R59 Input Supply Air Heating Setpoint

R59 sets supply air heating setpoint.

Valid range = 40° - 150°F

Applies only to units equipped with modulating gas heat.

# ReliaTel™ Dehumidification Module (RTDM)

## RTDM Layout - 27.5 to 50 tons

The RTDM is installed in the control box section for Voyager™ commercial units with modulating dehumidification.

**Figure 34. ReliaTel™ dehumidification module (RTDM) layout**

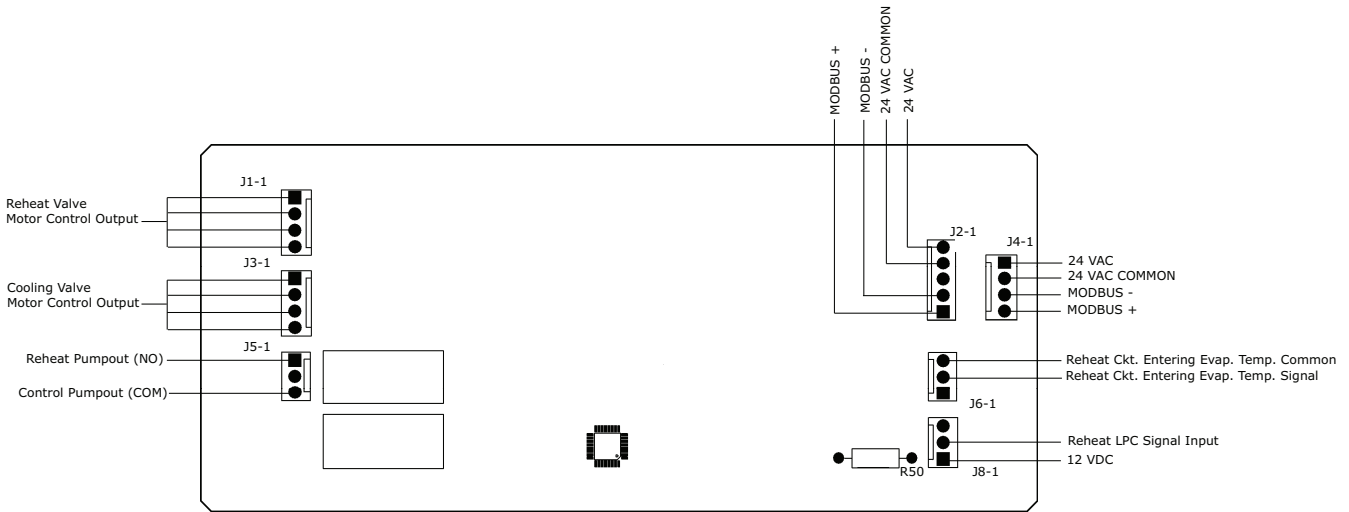

## RTDM Inputs/Outputs

### J4, J2 Inputs

J4 provides 24 Vac power in to the board and MODBUS communication to and from the RTRM.

J2 provides 24 Vac power and MODBUS communication to the RTOM.

### J6 Inputs

J6 - 2, 3 provides a temperature input for the reheat circuit entering evaporator temperature.

### J8 Inputs

J8 - 1, 2 provide 12 Vdc to the reheat LPC switch and an input for the reheat LPC signal.

### J1 Output

J1 - 1, 2, 3, 4 provides the output signals for the reheat valve stepper motor control.

### J3 Output

J3 - 1, 2, 3, 4 provides the output signals for the cooling valve stepper motor control.

### J5 Output

J5 - 1, 3 provides a normally open contact to be used for reheat pumpout solenoid control.



# ReliaTel™ Variable Speed Module (VSM)

Figure 35. ReliaTel™ variable speed module (VSM)

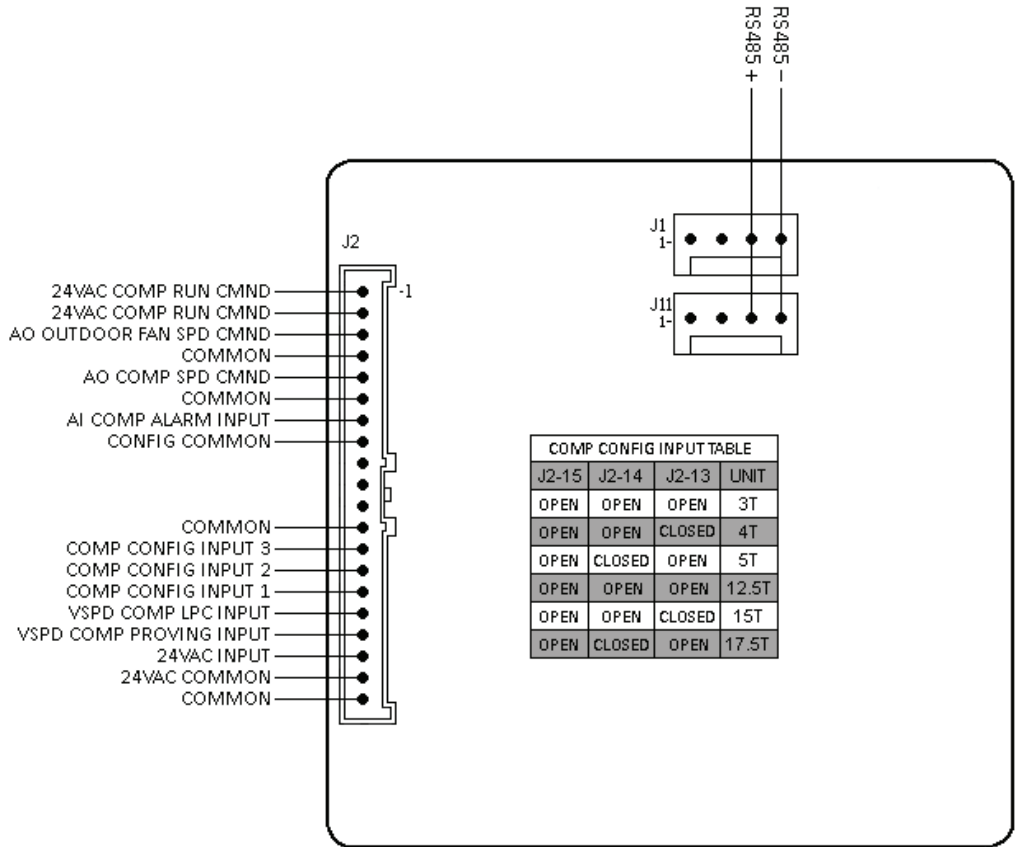

# Single Zone VAV, Multi-Speed, and 17 Plus

## Features and Operation - Voyager™ Light Commercial, Precedent™ and Odyssey™

Single zone variable air volume (SZVAV) and multi-speed evaporator fan operation was developed to meet ASHRAE 90.1 and California Title 24 requirements. Both SZVAV and multi-speed units reduce energy consumption by decreasing the indoor fan speed and reducing the compressor cooling stage during part load conditions. Efficiency at full load may not be affected but part load efficiency and energy savings is increased.

Single zone variable air volume (SZVAV) units must have ZSM or ICS controls.

**Important:** *SZVAV will not operate correctly with 24 Vac thermostats and it is not recommended on ultra high efficiency units.*

17 Plus and multi-speed units will work with 24 volt thermostats but 3 stages of cooling will not be available on 2 compressor units.

Single zone VAV and multi-speed evaporator fan units are neither designed to be discharge air controlled (DAC) units nor used in a multi-zone application (VAV boxes).

Single zone VAV fan units do have a discharge air setpoint limit that must be adjusted at start up but this only acts as a discharge temperature threshold. If the discharge air setpoint limit is set too high it will limit the cooling capacity of the unit. If the setpoint limit setting is unknown it is recommended that it be set all the way counter clockwise to the coolest setting. Precedent™ and Odyssey™ SZVAV units have a 3.3k ohm resistor which sets the limit to approximately 50°F but Voyager™ units use the R-136 **DA Cool - Fan Spd** potentiometer on the RTOM circuit board.

Different products use different methods to vary the evaporator fan speed. Voyager™ units use a variable frequency drive (VFD) to control evaporator fan speed but sheaves and pulleys are still used for maximum fan speed adjustment. Odyssey™ units also use a VFD in the air handler but unlike Voyager™ units, airflow is adjusted directly on the VFD keypad and by adjusting R-136 potentiometer on the RTOM circuit board. Precedent™ units do not use VFDs but instead use direct drive variable speed motors. Maximum airflow can be changed on both types of Precedent™ units by adjusting the R-136 potentiometer on the RTOM circuit board. Each unit's IOM will have specific information regarding verifying proper airflow.

### Enhanced Dehumidification

All 17 Plus units have the additional standard feature of enhanced dehumidification. Once the space humidity value exceeds the dehumidification setpoint on the RTOM (R 41) the unit will energize the first stage of cooling and drive the evaporator fan to low speed. Enhanced dehumidification is

terminated once space humidity falls below 2% of the humidity setpoint.

Enhanced dehumidification requires a field installed humidity sensor or a BAS provided space humidity value. A humidistat cannot be used with enhanced dehumidification. Enhanced dehumidification does not require the hot gas reheat (HGRH) option but will work in conjunction with HGRH as the first stage of dehumidification if present.

### General Sequence of Evaporator Fan Operation

The evaporator fan is energized approximately 1 second after a call for cooling or heating for all units except for those equipped with gas heat. Gas heat units energize the evaporator fan approximately 45 seconds after gas heat ignition. The RTRM de-energizes the evaporator fan approximately 160 seconds after a cooling call is satisfied and 90 seconds after a heating call is satisfied to enhance efficiency.

Precedent™ multi-speed units maintain the evaporator fan speed at approximately 50% (low speed) of maximum during fan on and economizer operation. After cooling stage 1 is energized the evaporator fan is ramped up to approximately 82% (medium speed) of maximum fan speed. If cooling stage 2, hot gas reheat (if equipped) or any stage of heat is called, the evaporator fan is ramped up to 100% (high speed) of maximum. Voyager™ and Odyssey™ multi-speed units will only have two speeds 100% high speed (used when both compressors are running and any stage heating) and approximately 50% on low speed (all other fan operations).

SZVAV units work differently than multi-speed units. SZVAV units modulate the evaporator fan based on the cooling demand of the space. The ReliaTel™ controller monitors the space temperature, space temperature deviation from setpoint, discharge air temperature, and space temperature recovery rate to determine the best airflow level. This control algorithm is not adjustable. Only the maximum airflow of the unit is adjustable.

On all multi-speed and SZVAV products the evaporator fan will operate at 100% (high speed) during any stage of heating except for Voyager™ units with modulating gas heat.

### Indoor Fan Control Description; Precedent™ 17 SEER (17 Plus) - Unit Identification

- The 7 in the 6th digit indicates the unit is a 17 Plus unit.
- YHC067E4RHA03D0A1000000000 - the 15th digit (0) indicates this model is a multi-speed evaporator fan unit.
- YHC067E3RHA03D6B0C1B0B000 - the 15th digit (6) indicates this is a SZVAV unit.

### Wiring and Configuration

Precedent™ 17 Plus, 3 to 5 tons (037, 047, and 067) units use a constant CFM ECM direct drive evaporator fan motor. Airflow is controlled by a pulse width modulated (PWM) output signal from the J11 header of the RTOM. It is important to note that the J-11 output controls the cfm but does not directly control fan speed. The ECM motor will determine actual rpm based on static pressure conditions and current draw of the motor to maintain the set cfm.

**Figure 36. 17 Plus, 3 to 5 tons airflow control configuration**

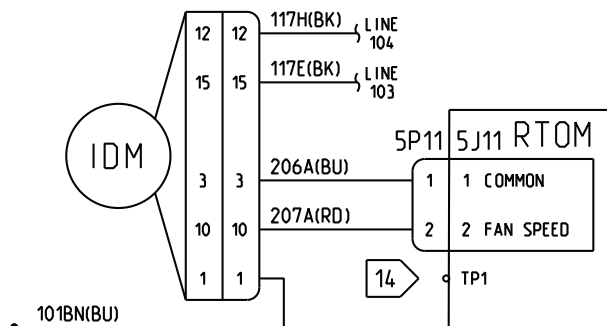

Multi-speed operation is standard on all 17 Plus units. Single zone VAV is available on 17 Plus units as a factory installed option.

Proper wiring configuration is required for correct unit operation. Wiring harness plugs should be configured as shown below for Precedent™ 17 Plus units.

**Figure 37. 17 Plus SZVAV configuration**

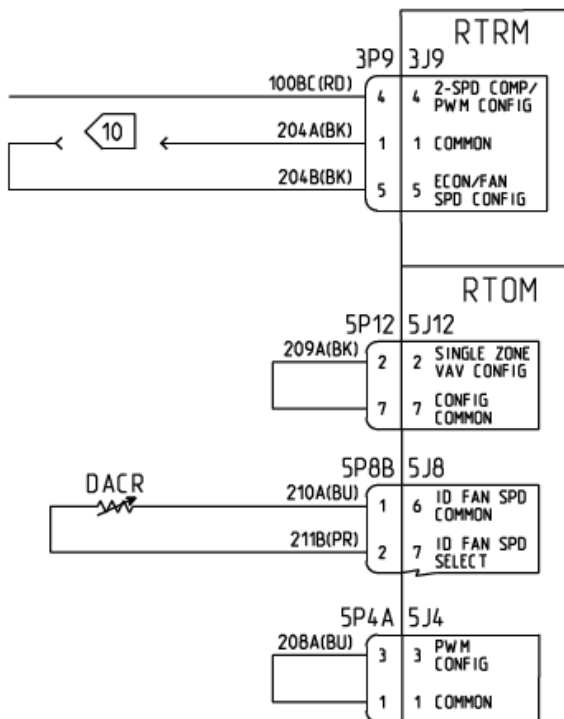

**Note:** Newer units use a DA cooling setpoint resistor (3.3k ohms) jumper harness part number WIR09782. The DA cooling setpoint resistor jumper harness sets the DA cooling setpoint to 50°F.

**Figure 38. 17 Plus standard (multi-speed) configuration**

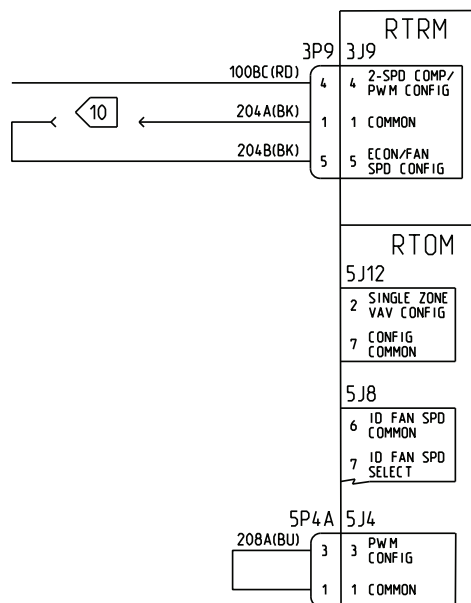

### Adjusting Maximum Unit Airflow

Make adjustments to the maximum airflow of a 17 Plus unit while in either cooling stage 2 or any stage of heat while in the factory test mode. This will force the indoor fan to maximum speed and ready for adjustment.

To change the maximum airflow, adjust the R-136 potentiometer on the RTOM.

**Note:** Voyager™ units use this potentiometer to set the discharge air setpoint limit.

**Figure 39. Adjusting airflow**

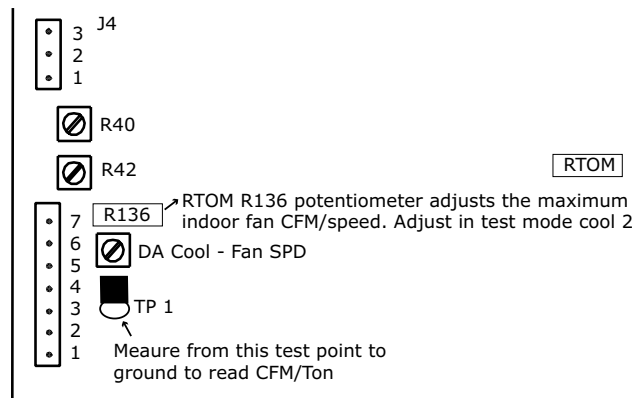

To verify the proper cfm setting, measure the DC voltage on the test point (TP1) next to R-136 and compare it to the cfm vs. Vdc chart. The cfm vs. Vdc chart is located on a

# Single Zone VAV, Multi-Speed, and 17 Plus

sticker on the fan housing and in the unit Installation, Operation, and Maintenance (IOM) manual.

**Note:** Reference service facts for fan specific Vdc settings as it relates to the required cfm settings.

## Indoor Fan Control Description; Backwards Curved (BC) Plenum Fan Control - Unit Identification

Digit 15 in the model number indicates whether the unit has a standard constant volume, multi-speed or SZVAV fan operation.

Examples:

- YSC120FWRLA01D6E0A1060004 is a SZVAV unit.
- YSC120FWRLA01D7E0A1060004 is a multi-speed unit.
- YSC120FWRLA01D0E0A1060004 is a standard constant volume indoor motor.

## Wiring and Configuration

6 to 10 tons standard and high efficiency Precedent™ units use a constant torque, backwards curved (BC), indoor fan motor. Airflow is controlled by a 0 to 10 Vdc output signal from the J11 header of the RTOM. The output is capable of sourcing 0 to 10 Vdc but the Precedent fan output is limited to a maximum of 7.6 Vdc in these models. Unlike the 17 Plus products this voltage level directly corresponds to fan rpm and not cfm.

**Figure 40. 17 Plus 7.5 to 10 tons airflow configuration**

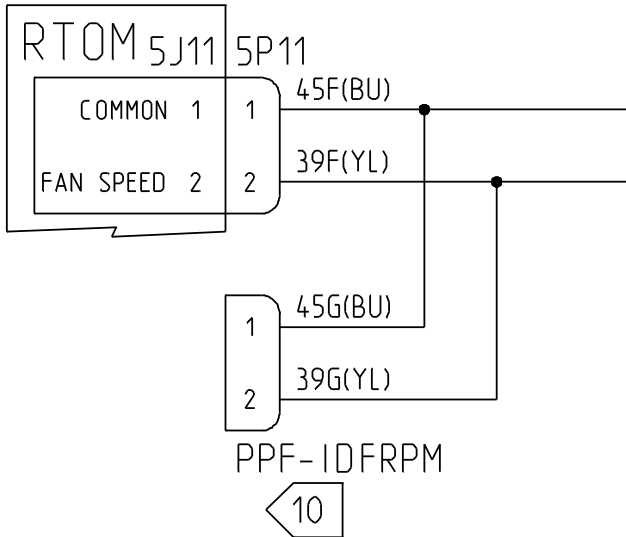

Measure the PPF-IDFRPM wire harness to check the potentiometer output.

Proper wiring configuration is required for correct unit operation. Wiring harness plugs should be configured as follows for 7.5 to 10 ton Precedent™ units.

**Figure 41. Precedent™ 7.5 to 10 tons SZVAV configuration**

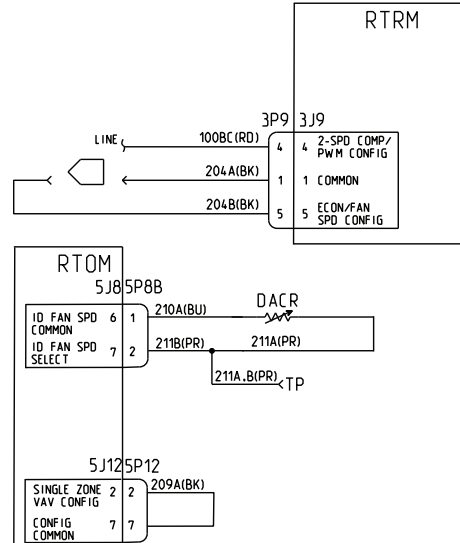

**Figure 42. Precedent™ 7.5 to 10 tons multi-speed configuration**

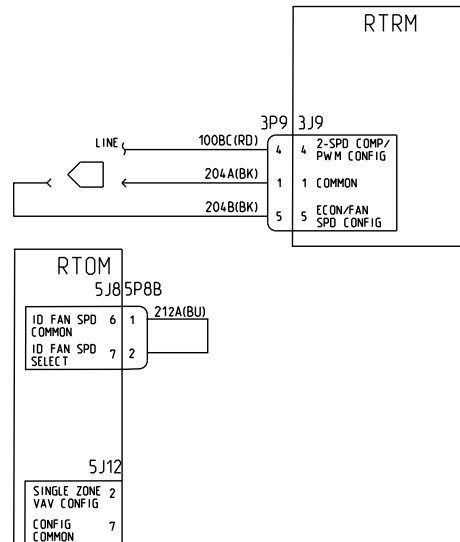

Figure 43. Precedent™ 7.5 to 10 tons standard configuration

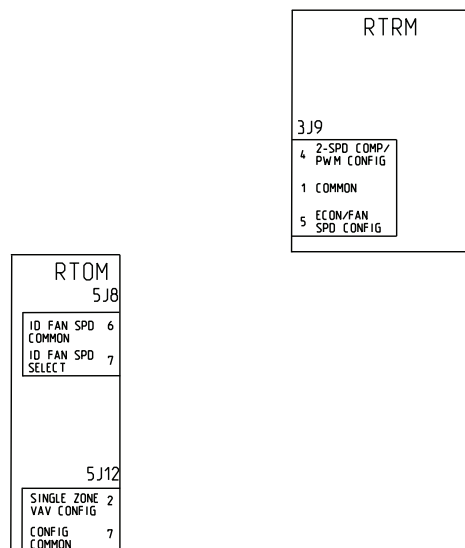
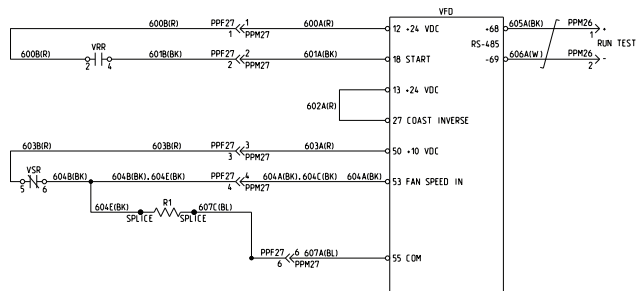
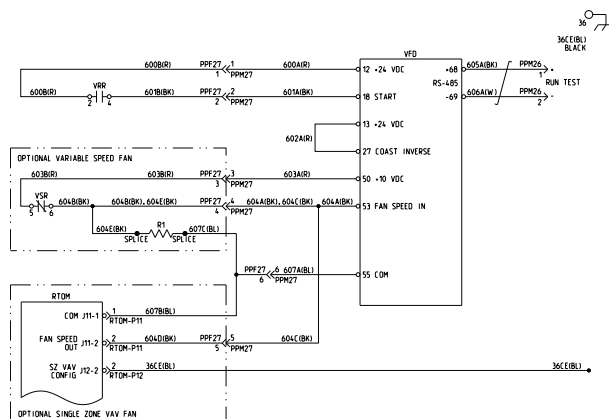

Figure 44. Multi-speed



Single zone VAV units use one relay and a vdc signal from the J-11 of the RTOM to modulate the fan speed.

Figure 45. Single zone VAV



### Adjusting Maximum Unit Airflow

Adjust the R-136 potentiometer on the RTOM (same as with 17 Plus) to change the potentiometer voltage (J-11 output) and thus change maximum fan speed. BC Plenum fan units will output a 0-7.6 Vdc signal from the RTOM J-11. The potentiometer voltage chart is located on a sticker on the fan housing and in the unit Installation, Operation, and Maintenance manual (IOM).

**Note:** Reference the service facts for the fan performance curves.

### Indoor Fan Control Description; Voyager™ Multi Speed and SZVAV VFD Controlled Evaporator Fan Motor - Unit Identification

Voyager™ units use a forward curved evaporator fan with a VFD controlled motor for multi speed and SZVAV options. Unit fan control type can be identified by the 9th digit in the model number. See the following chart.

| Fan type           | Standard | Multi-speed | SZVAV |
|--------------------|----------|-------------|-------|
| No heat (TC*, WC*) | 0 (zero) | A           | F     |
| Low heat           | L        | B           | G     |
| High heat          | H        | C           | H     |
| Mod heat           | V        | D           | K     |

**Note:** TCH241F4F0AB is a SZVAV unit without electric heat.

### Wiring and Configuration

Multi-speed units use two relays located in the control box to switch speeds at the VFD.

Proper wiring configuration is required for correct unit operation. Wiring harness plugs should be configured as shown below for Voyager™ units.

Figure 46. Voyager™ SZVAV configuration

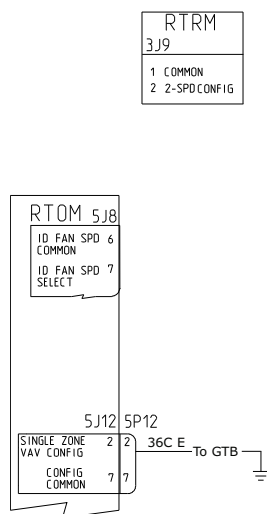

Figure 47. Voyager™ multi-speed configuration

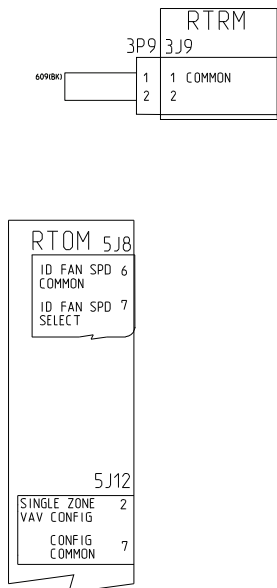
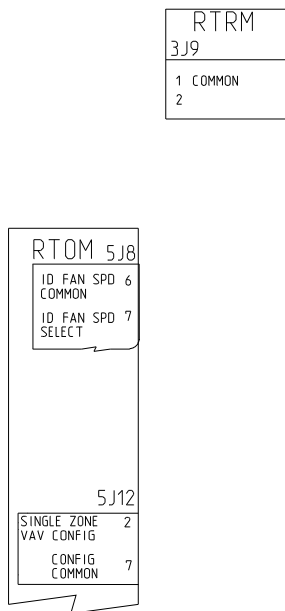

Figure 48. Voyager™ standard configuration



### Adjusting Maximum Unit Airflow - Voyager™ Light Commercial

Adjust the maximum airflow with sheaves and pulleys as one would with a standard unit. Verify adjustments in test mode in either maximum cooling (both compressors running) or any stage of heat.

Field adjustment of the VFD is not necessary or recommended with Voyager™ multi-speed or SZVAV packaged units.

### Indoor Fan Control Description; Odyssey™ Multi-Speed and SZVAV VFD Controlled Evaporator Fan Motor - Unit Identification

Digits 9 and 10 of the TWE air handler identify the air handler as standard constant volume, multi-speed or SZVAV.

| Fan type                      | Digits 9 and 10 |
|-------------------------------|-----------------|
| Standard constant volume      | 00              |
| Multi speed w/standard motor  | 03              |
| Multi speed w/oversized motor | 04              |
| SZVAV w/standard motor        | R3              |
| SZVAV w/oversized motor       | R4              |

**Note:** TWE240E3R4AB is a SZVAV with an oversized motor.

Oversized motors are only factory-installed options. Multi-speed air handlers **must** be paired with an electromechanical outdoor unit. SZVAV air handlers **must** be paired with ReliaTel™ controlled outdoor units.

Figure 49. Wiring and configuration - multi speed wiring (electromechanical only) - Odyssey™

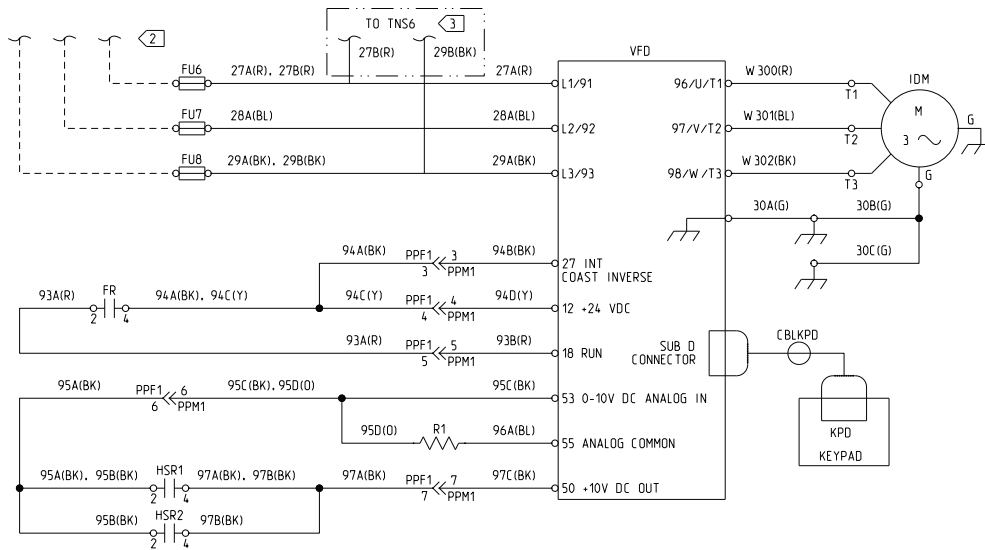

24 volt signals from the thermostat (Y, W, and G etc.) energize relays that command the VFD to the appropriate speed.

**SZVAV (ReliaTel™ Only) - Odyssey™**

Field wiring **must** be provided between the RTRM in the outdoor unit and the RTOM in the air handler.

Figure 50. SZVAV wiring (electromechanical only)

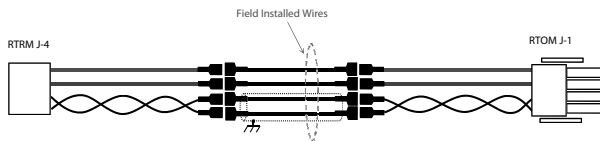

Communication wiring from the RTRM to the RTOM **must** be shielded and grounded at the outdoor unit **only**.

The RTRM communicates information to the RTOM regarding evaporator fan modulation. The RTOM then sends a 0-10 volt dc signal from the J-11 plug to the VFD to modulate the fan speed.

Figure 51. Odyssey™ RTOM

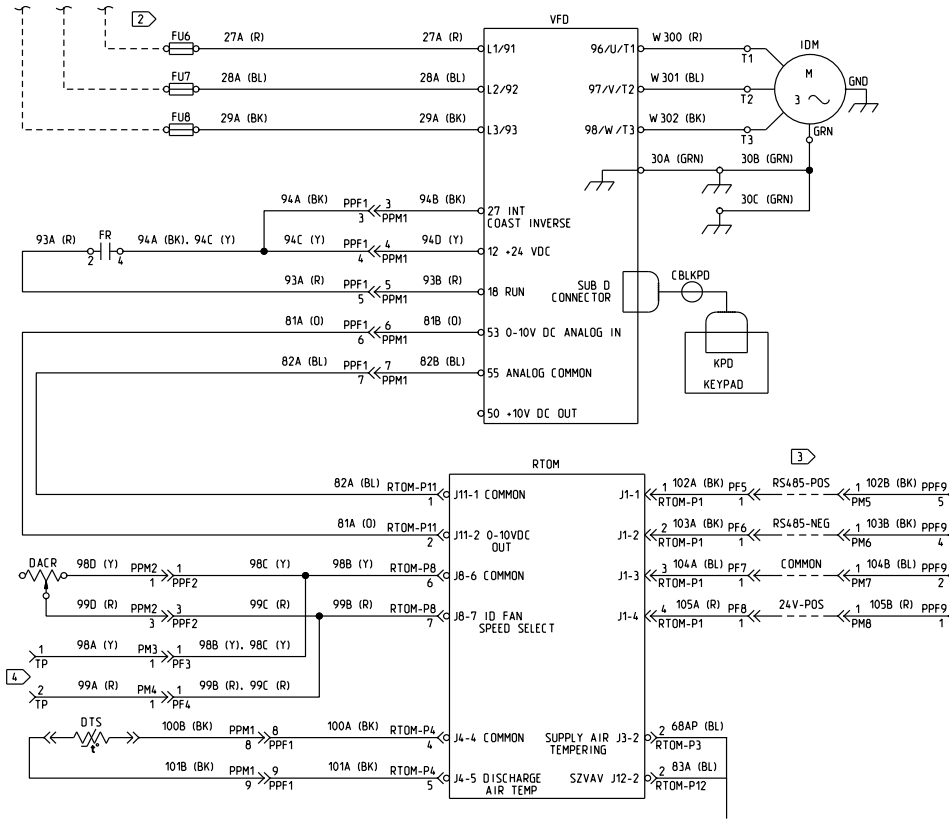

Proper wiring configuration is required for correct unit operation. Wiring harness plugs should be configured as shown below for Odyssey™ SZVAV units.

Figure 52. Odyssey™ SZVAV units

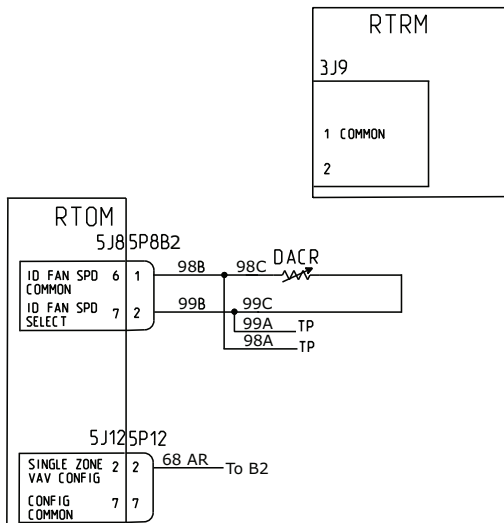

Multi-speed Odyssey™ units are electromechanical and do not require configuration jumpers.

### Adjusting Maximum Unit Airflow

Multi-speed (two speed) and SZVAV Odyssey™ split systems have a fixed motor pulley. Maximum and minimum airflow adjustment is accomplished by changing the frequency output of the air handler VFD (parameter 6-14) using the provided VFD keypad. Refer to the unit IOM for specific instructions on airflow adjustment.

SZVAV air handlers use a combination of adjusting the R-136 potentiometer on the RTOM (similar to Precedent™) and frequency parameter adjustment in the VFD. Refer to the unit IOM for specific instructions on airflow adjustment.

### SZVAV, Multi-Speed, DHC, WHC and 17 Plus Unit Outdoor Air Compensation and Economizer Minimum Position

Because of the need to maintain the same outdoor cfm during different fan speeds, set-up of the economizer minimum position is different than for constant volume units.

There are three speeds and damper positions to set-up, LOW, MEDIUM, and HIGH.



Figure 53. Setup of economizer minimum position

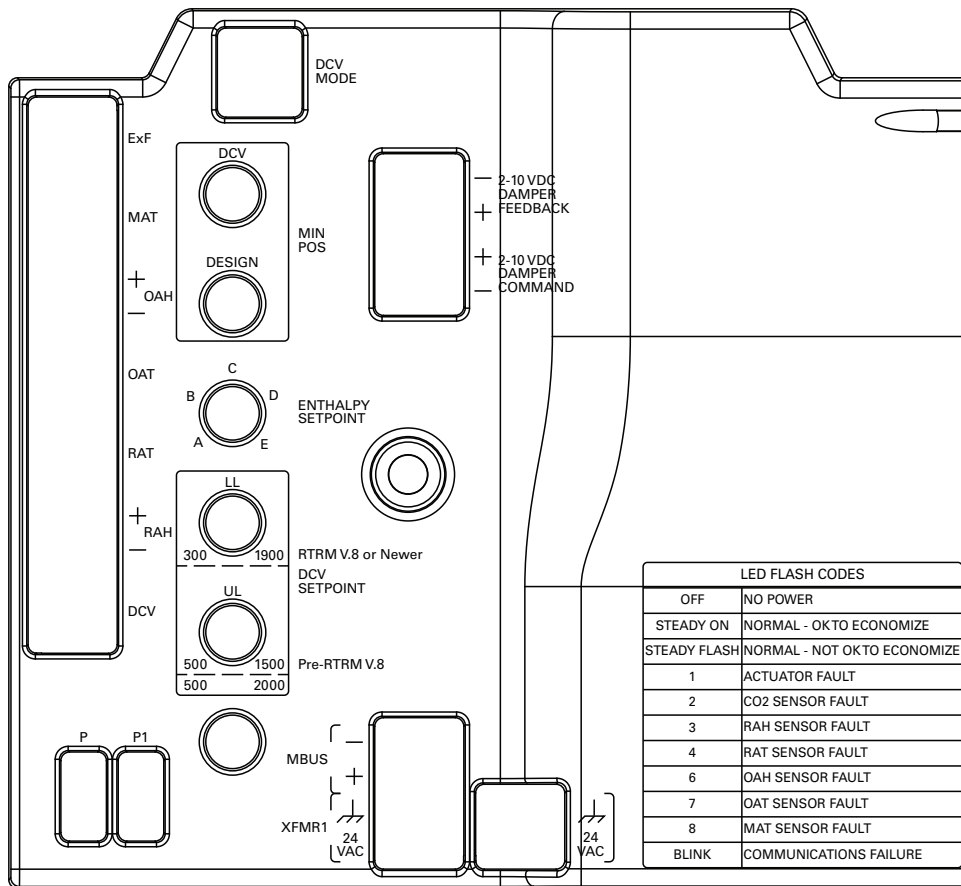

Damper minimum position adjustments should be done in the test mode.

- Test step 1 (supply fan) forces the supply fan to run at LOW speed. The minimum position of the economizer damper is allowed to travel between 0% and 100% when the fan is at LOW speed. This is adjusted by the DCV Min potentiometer on the RTEM.
- Test step 3 (compressor stage 1) forces the supply fan to run at MEDIUM speed. The minimum position of the economizer damper is allowed to travel between 0% and 75% when the fan is at Medium speed. This is adjusted by the LL potentiometer on the RTEM.
- Test step 4 (compressor stage 2) forces the supply fan to run at HIGH speed. The minimum position of the economizer damper is allowed to travel between 0% and 50% when the fan is at HIGH speed. This is adjusted by the DESIGN Min potentiometer on the RTEM.

BAS setpoints override any local potentiometer adjustments.

An economizer on a light commercial multi-speed supply fan or the single zone VAV option must have the fully populated, enhanced RTEM of at least version 2.0 or greater.

The powered exhaust setpoint should be set in the HIGH fan speed (test step 4, compressor stage 2). ReliaTel™ will determine an adjusted setpoint for other fan speeds based on this setting.

It is not recommend using a motorized damper with multi-speed or single zone VAV units.

## Condensate Drain Pan Overflow Switch

A condensate overflow condition will be detected by a condensate overflow float switch. When the condensate level reaches the trip point, the diagnostic condition will be detected. When the condensate overflow input CLOSES for 6 continuous seconds, the following actions will be taken by the ReliaTel™ controls:

- An auto-reset diagnostic will be generated. All compressor or heating operations will be disabled immediately. Condenser fans and compressors will be de-energized. Supply fan operation will be shutdown.
- Once the overflow condition has been cleared and the input is OPEN for 6 seconds, all diagnostic conditions will be cleared. The unit will return to normal operation. Auto-reset clearing will occur twice each time the unit is powered up. On the third occurrence, the unit will

initiate a lock-out and require manual reset. If an auto-reset overflow occurs once, but does not occur again for 72 hours, the trip counter will reset allowing more auto-resets to occur.

- If overflow occurs during morning warm up (MWU) or daytime warm up (DWU), the unit will not return to warm up once diagnostic has been cleared. If the zone temperature remains lower than the initiate setpoint for DWU, the unit will enter DWU upon reset.
- If overflow trip occurs during a purge cycle on dehumidification, purge will discontinue, but will resume with a full 3 minute counter upon reset of the trip.
- If unit power cycle is used to reset a trip, the unit will not carry forward any previous mode.
- During manufacturing test mode, the overflow trip indication will be reflected in the Modbus/BAS data packets, but will not result in shutdown of any unit components. The lockout trip counter will also be continually reset to zero to allow unlimited trips during this mode.

## Fresh Air Measurement and Control (Traq™)

Fresh air measurement and control function measures the airflow through the outdoor air damper. Using this measurement and comparing it with the desired temperature, this function can vary the position of the damper to keep the fresh air flow within the specified range to maintain the desired temperature.

**Service Test - Traq™ control functionality** will be active during service test in all steps where the outside air (OA) damper is held in the minimum position. This would be all steps except the economizing step which forces the damper open to 100%.

**Sensor calibration adjustment** - To make a minor correction to the Traq™ airflow reading that is calculated internally by the ReliaTel™ system an adjustment pot is available on the RTVM. This pot can be used to correct for static local factors such as altitude. Variable factors such as drift, temperature, humidity, and other changing atmospheric conditions are corrected as part of the conversion calculation.

## Sequence for Setting Calibration

1. Adjust the minimum OA flow setpoint on the RTVM to desired flow rate for minimum ventilation. Use voltage vs CFM chart.
2. Initiate service test and step to the minimum ventilation step. This will set the unit into a constant ID fan speed and OA damper request to minimum position. Minimum position will be from the Traq™ calculation to maintain the OA flow at the setpoint in "Step 1," p. 62.
3. Wait for the damper position to settle to the desired flow rate set by the setpoint. It should take about one minute.

4. Measure OA flow rate via an air balancing instrument.
5. Adjust calibration pot clockwise or counter-clockwise to dial-in the flow to match instrument in "Step 4," p. 62.

**Table 15. Design minimum OA flow setpoints**

| Design Min OA Flow Setpoint (R130) | DCV Min OA Flow Setpoint (R41) | Voltage Reading |
|------------------------------------|--------------------------------|-----------------|
| Airflow CFM                        | Airflow CFM                    | Voltage VDC     |
| 1000                               | 1000                           | 0.2             |
| 1100                               | 1100                           | 0.22            |
| 1200                               | 1200                           | 0.24            |
| 1300                               | 1300                           | 0.26            |
| 1400                               | 1400                           | 0.28            |
| 1500                               | 1500                           | 0.3             |
| 1600                               | 1600                           | 0.32            |
| 1700                               | 1700                           | 0.34            |
| 1800                               | 1800                           | 0.36            |
| 1900                               | 1900                           | 0.38            |
| 2000                               | 2000                           | 0.4             |
| 2100                               | 2100                           | 0.42            |
| 2200                               | 2200                           | 0.44            |
| 2300                               | 2300                           | 0.46            |
| 2400                               | 2400                           | 0.48            |
| 2500                               | 2500                           | 0.5             |
| 2600                               | 2600                           | 0.52            |
| 2700                               | 2700                           | 0.54            |
| 2800                               | 2800                           | 0.56            |
| 2900                               | 2900                           | 0.58            |
| 3000                               | 3000                           | 0.6             |
| 3100                               | 3100                           | 0.62            |
| 3200                               | 3200                           | 0.64            |
| 3300                               | 3300                           | 0.66            |
| 3400                               | 3400                           | 0.68            |
| 3500                               | 3500                           | 0.7             |
| 3600                               | 3600                           | 0.72            |
| 3700                               | 3700                           | 0.74            |
| 3800                               | 3800                           | 0.76            |
| 3900                               | 3900                           | 0.78            |
| 4000                               | 4000                           | 0.8             |
| 4100                               | 4100                           | 0.82            |
| 4200                               | 4200                           | 0.84            |
| 4300                               | 4300                           | 0.86            |
| 4400                               | 4400                           | 0.88            |
| 4500                               | 4500                           | 0.9             |
| 4600                               | 4600                           | 0.92            |
| 4700                               | 4700                           | 0.94            |
| 4800                               | 4800                           | 0.96            |
| 4900                               | 4900                           | 0.98            |
| 5000                               | 5000                           | 1               |
| 5100                               | 5100                           | 1.01            |
| 5200                               | 5200                           | 1.02            |
| 5300                               | 5300                           | 1.03            |
| 5400                               | 5400                           | 1.04            |
| 5500                               | 5500                           | 1.05            |
| 5600                               | 5600                           | 1.06            |
| 5700                               | 5700                           | 1.07            |
| 5800                               | 5800                           | 1.08            |
| 5900                               | 5900                           | 1.09            |
| 6000                               | 6000                           | 1.1             |
| 6100                               | 6100                           | 1.11            |
| 6200                               | 6200                           | 1.12            |
| 6300                               | 6300                           | 1.13            |
| 6400                               | 6400                           | 1.15            |

Table 15. Design minimum OA flow setpoints (continued)

| Design Min OA Flow Setpoint (R130) | DCV Min OA Flow Setpoint (R41) | Voltage Reading |
|------------------------------------|--------------------------------|-----------------|
| Airflow CFM                        | Airflow CFM                    | Voltage VDC     |
| 6500                               | 6500                           | 1.17            |
| 6600                               | 6600                           | 1.18            |
| 6700                               | 6700                           | 1.19            |
| 6800                               | 6800                           | 1.2             |
| 6900                               | 6900                           | 1.22            |
| 7000                               | 7000                           | 1.23            |
| 7100                               | 7100                           | 1.24            |
| 7200                               | 7200                           | 1.25            |
| 7300                               | 7300                           | 1.26            |
| 7400                               | 7400                           | 1.27            |
| 7500                               | 7500                           | 1.28            |
| 7600                               | 7600                           | 1.29            |
| 7700                               | 7700                           | 1.3             |
| 7800                               | 7800                           | 1.31            |
| 7900                               | 7900                           | 1.32            |
| 8000                               | 8000                           | 1.34            |
| 8100                               | 8100                           | 1.36            |
| 8200                               | 8200                           | 1.38            |
| 8300                               | 8300                           | 1.39            |
| 8400                               | 8400                           | 1.4             |
| 8500                               | 8500                           | 1.41            |
| 8600                               | 8600                           | 1.42            |
| 8700                               | 8700                           | 1.43            |
| 8800                               | 8800                           | 1.44            |
| 8900                               | 8900                           | 1.45            |
| 9000                               | 9000                           | 1.46            |
| 9100                               | 9100                           | 1.47            |
| 9200                               | 9200                           | 1.48            |
| 9300                               | 9300                           | 1.5             |
| 9400                               | 9400                           | 1.52            |
| 9500                               | 9500                           | 1.53            |
| 9600                               | 9600                           | 1.54            |
| 9700                               | 9700                           | 1.55            |
| 9800                               | 9800                           | 1.57            |
| 9900                               | 9900                           | 1.58            |
| 10000                              | 10000                          | 1.59            |
| 10100                              | 10100                          | 1.6             |
| 10200                              | 10200                          | 1.61            |
| 10300                              | 10300                          | 1.63            |
| 10400                              | 10400                          | 1.65            |
| 10500                              | 10500                          | 1.67            |
| 10600                              | 10600                          | 1.68            |
| 10700                              | 10700                          | 1.69            |
| 10800                              | 10800                          | 1.7             |
| 10900                              | 10900                          | 1.71            |
| 11000                              | 11000                          | 1.72            |
| 11100                              | 11100                          | 1.73            |
| 11200                              | 11200                          | 1.74            |
| 11300                              | 11300                          | 1.74            |
| 11400                              | 11400                          | 1.75            |
| 11500                              | 11500                          | 1.76            |
| 11600                              | 11600                          | 1.77            |
| 11700                              | 11700                          | 1.78            |
| 11800                              | 11800                          | 1.79            |
| 11900                              | 11900                          | 1.8             |
| 12000                              | 12000                          | 1.81            |
| 12100                              | 12100                          | 1.82            |
| 12200                              | 12200                          | 1.83            |
| 12300                              | 12300                          | 1.84            |

Table 15. Design minimum OA flow setpoints (continued)

| Design Min OA Flow Setpoint (R130) | DCV Min OA Flow Setpoint (R41) | Voltage Reading |
|------------------------------------|--------------------------------|-----------------|
| Airflow CFM                        | Airflow CFM                    | Voltage VDC     |
| 12400                              | 12400                          | 1.85            |
| 12500                              | 12500                          | 1.86            |
| 12600                              | 12600                          | 1.87            |
| 12700                              | 12700                          | 1.88            |
| 12800                              | 12800                          | 1.89            |
| 12900                              | 12900                          | 1.89            |
| 13000                              | 13000                          | 1.89            |
| 13100                              | 13100                          | 1.9             |
| 13200                              | 13200                          | 1.91            |
| 13300                              | 13300                          | 1.92            |
| 13400                              | 13400                          | 1.93            |
| 13500                              | 13500                          | 1.94            |
| 13600                              | 13600                          | 1.95            |
| 13700                              | 13700                          | 1.96            |
| 13800                              | 13800                          | 1.97            |
| 13900                              | 13900                          | 1.98            |
| 14000                              | 14000                          | 1.99            |
| 14100                              | 14100                          | 2               |
| 14200                              | 14200                          | 2.01            |
| 14300                              | 14300                          | 2.02            |
| 14400                              | 14400                          | 2.03            |
| 14500                              | 14500                          | 2.04            |
| 14600                              | 14600                          | 2.05            |
| 14700                              | 14700                          | 2.06            |
| 14800                              | 14800                          | 2.07            |
| 14900                              | 14900                          | 2.08            |
| 15000                              | 15000                          | 2.09            |
| 15100                              | 15100                          | 2.1             |
| 15200                              | 15200                          | 2.11            |
| 15300                              | 15300                          | 2.12            |
| 15400                              | 15400                          | 2.13            |
| 15500                              | 15500                          | 2.14            |
| 15600                              | 15600                          | 2.15            |
| 15700                              | 15700                          | 2.16            |
| 15800                              | 15800                          | 2.17            |
| 15900                              | 15900                          | 2.18            |
| 16000                              | 16000                          | 2.19            |
| 16100                              | 16100                          | 2.2             |
| 16200                              | 16200                          | 2.21            |
| 16300                              | 16300                          | 2.22            |
| 16400                              | 16400                          | 2.23            |
| 16500                              | 16500                          | 2.24            |
| 16600                              | 16600                          | 2.25            |
| 16700                              | 16700                          | 2.26            |
| 16800                              | 16800                          | 2.27            |
| 16900                              | 16900                          | 2.28            |
| 17000                              | 17000                          | 2.29            |
| 17100                              | 17100                          | 2.3             |
| 17200                              | 17200                          | 2.31            |
| 17300                              | 17300                          | 2.32            |
| 17400                              | 17400                          | 2.33            |
| 17500                              | 17500                          | 2.34            |
| 17600                              | 17600                          | 2.35            |
| 17700                              | 17700                          | 2.36            |
| 17800                              | 17800                          | 2.37            |
| 17900                              | 17900                          | 2.38            |
| 18000                              | 18000                          | 2.39            |
| 18100                              | 18100                          | 2.4             |
| 18200                              | 18200                          | 2.41            |

Table 15. Design minimum OA flow setpoints (continued)

| Design Min OA Flow Setpoint (R130) | DCV Min OA Flow Setpoint (R41) | Voltage Reading |
|------------------------------------|--------------------------------|-----------------|
| Airflow CFM                        | Airflow CFM                    | Voltage VDC     |
| 18300                              | 18300                          | 2.42            |
| 18400                              | 18400                          | 2.43            |
| 18500                              | 18500                          | 2.44            |
| 18600                              | 18600                          | 2.45            |
| 18700                              | 18700                          | 2.46            |
| 18800                              | 18800                          | 2.47            |
| 18900                              | 18900                          | 2.48            |
| 19000                              | 19000                          | 2.49            |

Table 16. OA flow adjustment setpoints

| OA Flow Adjustment (R136) | Voltage Reading |
|---------------------------|-----------------|
| Multiplier/ Adjustment    | VDC             |
| 0.8                       | 0               |
| 0.81                      | 0.05            |
| 0.82                      | 0.14            |
| 0.83                      | 0.22            |
| 0.84                      | 0.3             |
| 0.85                      | 0.35            |
| 0.86                      | 0.43            |
| 0.87                      | 0.51            |
| 0.88                      | 0.57            |
| 0.89                      | 0.64            |
| 0.9                       | 0.72            |
| 0.91                      | 0.78            |
| 0.92                      | 0.88            |
| 0.93                      | 0.94            |
| 0.94                      | 1               |
| 0.95                      | 1.06            |
| 0.96                      | 1.1             |
| 0.97                      | 1.18            |
| 0.98                      | 1.22            |
| 0.99                      | 1.25            |

Table 16. OA flow adjustment setpoints (continued)

| OA Flow Adjustment (R136) | Voltage Reading |
|---------------------------|-----------------|
| Multiplier/ Adjustment    | VDC             |
| 1                         | 1.3 - 1.84      |
| 1.01                      | 1.86            |
| 1.02                      | 1.89            |
| 1.03                      | 1.92            |
| 1.04                      | 1.96            |
| 1.05                      | 2               |
| 1.06                      | 2.03            |
| 1.07                      | 2.06            |
| 1.08                      | 2.1             |
| 1.09                      | 2.12            |
| 1.1                       | 2.14            |
| 1.11                      | 2.16            |
| 1.12                      | 2.18            |
| 1.13                      | 2.2             |
| 1.14                      | 2.24            |
| 1.15                      | 2.26            |
| 1.16                      | 2.28            |
| 1.17                      | 2.3             |
| 1.18                      | 2.34            |
| 1.19                      | 2.36            |
| 1.2                       | 2.4             |

### Economizer Fault Detection and Diagnostics

Fault detection of the outdoor air damper will be evaluated based on the commanded position of the damper compared to the feedback position of the damper. The damper is commanded to a position based on a 2-10 Vdc signal.

**Note:** In table below, not economizing when should and economizing when should not be have been determined.

Table 17. Economizer fault detection and diagnostics for units with or without Traq™

| Cooling Request   | Enthalpy Decision | Indoor Fan - (Ventilation Requested) | Damper Command VS Feedback                   | Not Economizing When It Should Be | Economizing When It Should Not Be | Outdoor Air Damper Not Modulating | Excessive Outdoor Air |
|-------------------|-------------------|--------------------------------------|--|-----------------------------------|-----------------------------------|-----------------------------------|-----------------------|
| N/A               | N/A               | N/A                                  | Feedback - 10% <= Setpoint <= Feedback + 10% | (no fault)                        | (no fault)                        | (no fault)                        | (no fault)            |
| N/A               | N/A               | OFF                                  | Feedback High                                |                                   |                                   |                                   | FAULT                 |
| NO <sup>(a)</sup> | N/A               | ON                                   | Feedback High                                |                                   |                                   |                                   | FAULT                 |
| NO <sup>(a)</sup> | N/A               | ON                                   | Feedback Low                                 |                                   |                                   | FAULT                             |                       |
| YES               | Enabled           | ON                                   | Feedback High                                |                                   | FAULT                             |                                   |                       |
| YES               | Enabled           | ON                                   | Feedback Low                                 | FAULT                             |                                   |                                   |                       |
| YES               | Disabled          | ON                                   | Feedback High                                |                                   |                                   |                                   | FAULT                 |
| YES               | Disabled          | ON                                   | Feedback Low                                 |                                   |                                   | FAULT                             |                       |

<sup>(a)</sup> Dehumidification mode and heating mode are considered minimum ventilation.

**Figure 54. Fault detection and diagnostics (FDD) for low leak economizer (LLE) – TD-5 display**

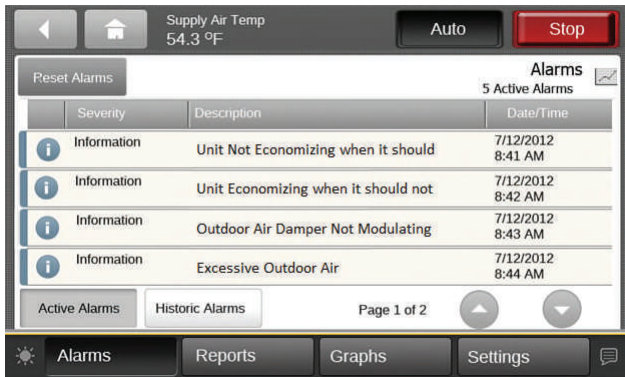

When an economizer fault has been detected, the unit controller will latch an auto-reset diagnostic and report it through the TD-5. It will also generate a diagnostic through BAS (LCI/BCI if installed). **Reset** auto-reset diagnostic when the economizer returns to the valid range or if the unit leaves active cooling mode.

### Mixed Air Temperature Low Limit Diagnostic

In all conditions on all ReliaTel™ controlled units, if the mixed air temperature falls below 45°F, mixed air temperature low limit is active and the economizer actuator will close to the active minimum position. On Title 24 compliant units, ReliaTel™ will set an auto-reset diagnostic to be used by BAS and TD-5 when the mixed air temperature low limit is active.

The RTEM will revert to normal operation when the mixed air temperature rises above 48°F. The diagnostic will be reset when the mixed air temperature low limit is inactive.

### BACnet® Communications Interface (BCI)

Refer to the list below for a list of objects in the BCI interface that require specific handling in regards to economizer fault detection and diagnostics:

- Diagnostic: Unit not economizing when it should be
- Diagnostic: Unit economizing when it should not be
- Diagnostic: Outdoor air damper not modulating
- Diagnostic: Excessive outdoor air
- Diagnostic: Mixed air temperature low limit active

### LonTalk® Communications Interface (LCI)

Refer to the list below for the variables in the LCI interface that require specific handling in regards to economizer fault detection and diagnostics:

- nvoAlarmMessage.Unit Not Economizing
- nvoAlarmMessage.Unit Economizing

- nvoAlarmMessage.OA Damper Not Modulating
- nvoAlarmMessage.Excessive Outdoor Air
- nvoAlarmMessage.Mixed Air Temperature Low Limit Active

### Failure and Overriding Conditions

Economizer FDD will continue to be in effect during the following cases:

- Service Test Mode
- Ventilation Override
- OFF or Stop Mode

### Multi-Speed Indoor Fan

There will be two types of multi-speed indoor fan control. The first type will control discrete fan speeds based on active heating or cooling stages and the second will be a modulating type control based on various inputs.

### Two-Speed Fan Control

This control scheme will cover all unit operation for units configured for two-speed fan operation. Units requiring discrete relay outputs or voltage signals (5 Vdc and 10 Vdc) will fall under this form of control.

**Table 18. Control scheme - two speed fan control**

| Unit Configuration           | Low Speed Output  | High Speed Output  |
|------------------------------|---|--|
| 2-Speed Relay Controlled     | RTRM Supply Fan Output + RTRM J2-5 Output                       | RTRM Supply Fan Output   |
| 2-Speed 5 Vdc/ 10 Vdc Output | RTRM Supply Fan Output + RTOM Indoor Fan Speed @ 50% of maximum | RTRM Supply Fan Output + RTOM Indoor Fan Speed @ 100% of maximum |

### Unit Operation for Two-Speed Fan Control

Standard unit operation for cooling, heating, and dehumidification will continue on units equipped with a two-speed indoor fan and all unit functions will operate normally, except for the control of the indoor fan speed. All units configured with any type of heating or reheat/ dehumidification will operate as normal utilizing full speed indoor fan by energizing the appropriate output(s) as described above. The two-speed indoor fan unit will only utilize two speeds during the modes described below.

### Cooling Operation

For cooling operation, the unit will utilize low fan speed during fan only and economizer only unit modes. When the unit receives a call for cooling, if the economizer is enabled, the unit will energize the fan at low speed and begin to modulate the OA damper open above minimum position up to 100% as necessary to meet the mixed air setpoint. If the OA damper reaches 100% the supply fan will increase to high speed and if it remains there for 5

minutes, the unit will begin to stage up compressors and the supply fan will remain at high speed for the remainder of the call for cooling.

For two-step cool units, when the unit enters Cool 1 with economizer disabled, the supply fan will energize at low speed for the duration of Cool 1. When the unit determines that the 2nd compressor is necessary to meet cooling demands, the unit will energize the 2nd compressor and the supply fan will switch to high speed. For 3-step cool units the unit will utilize low fan speed during requests for Cool 1 and Cool 2 during cooling operation. High fan speed will be utilized only for Cool 3.

The unit will stage down compressors for cooling in reverse order that they were staged and the supply fan will follow the unit mode transitions. Once it is determined through normal cooling control that the 2nd compressor is no longer necessary to meet cooling demand, the 2nd compressor will be staged back and the supply fan will switch to low speed until the unit stages all cooling off or receives a call for Cool 2 again. Once the supply fan is no longer requested ON after a cooling call is cleared, the supply fan will remain energized at low speed for 60 seconds.

### Economizer Minimum Position Handling for Two-Speed Fan

Due to the low and high speeds of the indoor fan, when the unit is in Fan Only, Cool 1, or Economizer Only modes the control will require the setting of two economizer minimum positions. The economizer minimum position that will be utilized while the supply fan is at low speed will be set with the RTEM DCV minimum position pot (0-100%) and the minimum position that will be utilized while the supply fan is at high speed will be set with the RTEM building design minimum position pot (0-50%). If the building design minimum position is set to be higher than the DCV min position, the setpoints will be capped at the DCV min position and the setpoint for the min position at low and high fan speed will be the DCV min position.

### Demand Controlled Ventilation Operation

DCV for units with two-speed supply fans will require an additional module (RTVM) for the two additional setpoint potentiometers necessary.

The new DCV scheme will require the user to select four OA damper minimum position setpoints in addition to the Design and DCV CO<sub>2</sub> setpoints:

- Design Min Position @ Low Fan Speed Command (RTVM R130)
- Design Min Position @ High Fan Speed Command (RTEM Design Min)
- DCV Min Position @ Low Fan Speed Command (RTVM R41)
- DCV Min Position @ High Fan Speed Command (RTEM DCV Min)

The speed at which the supply fan operates will dictate which design and DCV minimum position setpoint is used.

### Space Pressure Control (Powered Exhaust/ Statitrac™)

For two-speed supply fan units, the user will select an exhaust enable setpoint during the full fan speed command. Once selected, the exhaust enable setpoint for low fan speed operation will be calculated.

### Failure and Override Modes

- Supply fan proving - If there is a supply fan failure condition all outputs associated with the supply fan output control will be de-energized.
- Ventilation override mode - For all VOM modes that require supply fan operation (purge and pressurize), the supply fan will operate at high speed.
- All failure modes that require the supply fan to operate, the supply fan will energize at high speed.

### Fan Speed Selection for Two-Speed Analog Output Units

For units equipped with an analog speed controlled motor for two-speed indoor fan control, the user will have the ability to fine tune the high and low fan speeds by adjusting the potentiometer provided on the RTOM board (R136 DACOOL-FAN SPD) to get the desired output voltage for high fan speed. The RTOM will provide 50% and 100% of this user selected output voltage for the low and high fan speeds respectively. During service test mode when the RTOM indoor fan speed output is set to 100% for Cool 2, reheat, and all heating steps, the user can adjust the RTOM potentiometer to provide the appropriate 0-10 Vdc input signal to the analog speed controlled motor for high speed. For all other steps in which the RTOM indoor fan speed output is providing 50%, the motor will receive half of the adjusted voltage for low speed.

### Multi-Speed PWM Controlled Indoor Fan with Dual Capacity Compressor

This control scheme will cover DHC/WHC 17 SEER 3 to 5 ton Precedent™ units equipped with a PWM controlled indoor fan motor for multi-speed control and a dual capacity compressor.

### Configuration

Units equipped with a PWM controlled indoor fan motor and a dual capacity compressor will be configured uniquely within the ReliaTel™ system by being configured as a non-heat pump, two compressor unit with two step cooling and the RTRM J9-4 closed to 24 Vac. Also, the RTOM J4-3 will be closed to ground for PWM control.

### Unit Operation for Multi-Speed PWM Controlled Indoor Fan

Unit operation for Multi-Speed PWM controlled indoor fan units will be similar to the control of standard two compressor, two step cooling units with the exception of the multi-speed characteristics of the PWM controlled indoor fan motor and special handling required for the dual

capacity compressor. For indoor fan control, the supply fan will follow the airflow profiles as described in the following sections during all active cooling modes. During all active heating modes, the unit will utilize full indoor fan speed based on the selected maximum fan speed.

**Airflow Profiles**

**Figure 55. Airflow staging**

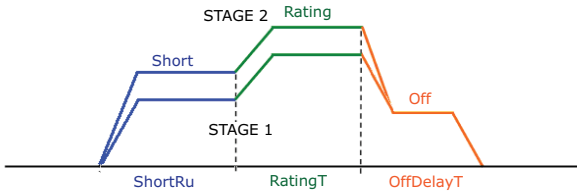

The following airflow profile table will be used in determining the PWM output signal for the associated cooling stages.

**Table 19. Airflow profiles**

| PWM Mode                       | Short Run Time | Short Run Fan Output % | Rating Run Time | Rating Output % | Off Delay Time | Off Delay Signal % |
|--------------------------------|----------------|------------------------|-----------------|-----------------|----------------|--------------------|
| Stage 1 Operation              |                |                        |                 |                 |                |                    |
| 1st Stage Airflow              | 7.5 mins       | 57%                    | Any             | 70%             | 160 secs       | 50%                |
| Compressor Output at 1st Stage | 7.5 mins       | 67%                    | Any             | 67%             |                | 0%                 |
| Stage 2 Operation              |                |                        |                 |                 |                |                    |
| 2nd Stage Airflow              | 7.5 mins       | 82%                    | Any             | 100%            | 160 secs       | 50%                |
| Compressor Output at 2nd Stage | 7.5 mins       | 100%                   | Any             | 100%            |                | 0%                 |

**Note:** The rating output percent refers to the maximum fan speed signal as a percentage of the user selected unit maximum airflow that will be applied to the indoor fan for the duration of time that the unit runs at the associated compressor stage.

**High Fan Speed Selection**

Each motor program will include an upper CFM setpoint and the user will then have the ability to adjust R136/ DACSP onboard potentiometer located on the RTOM to select the proper unit/application specific maximum airflow. At the maximum (full clockwise on the potentiometer), ReliaTel™ will output 100% of the maximum PWM signal from the RTOM indoor fan speed output (J11 - 2, 1) for control. At the minimum (full counterclockwise), ReliaTel™ will output 70% of the maximum PWM signal for control. Once a maximum value is selected via the onboard potentiometer, ReliaTel™ will control the indoor fan speed to the previously described airflow profiles utilizing the

maximum set value as the reference point (100% rating) for all percentages.

**Fan Only Operation**

When the RTRM receives a call for fan only mode, the unit will energize the RTRM supply fan output and the RTOM will begin to output a PWM signal at 50% of the high stage airflow PWM signal and remain there for the duration of the call.

**Fan Off Delay (from Cooling)**

When the supply fan is commanded off due to no call, the supply fan will ramp down to a signal that is 50% of the high stage airflow PWM signal and will remain energized at that speed for a total of 160 seconds.

**Cooling Operation**

For cooling operation the unit will utilize normal ReliaTel™ cooling control schemes for a two compressor unit, but instead of each compressor output being connected to an independent compressor, they will be connected to the dual capacity compressor for control. The compressor one output signal will energize the dual capacity compressor and operate it at 67% of its total capacity. The compressor two output signal is connected to a solenoid on the compressor that when energized allows the compressor to operate at full capacity.

When the unit receives a call for cooling, if the economizer is enabled, the unit will energize the supply fan at low speed and begin to modulate the OA damper open above minimum position up to 100% as necessary to meet the mixed air temperature setpoint. If the OA damper reaches 100% the supply fan will increase to maximum speed and remain there for 5 minutes. The unit will then begin to energize the compressor outputs to meet cooling demand.

If the economizer is not enabled and the unit enters Cool 1 due to normal cooling control schemes, the supply fan will energize and will start operation at the low speed of 1st stage airflow profile. If no other calls for stage 2 of cooling are present, the unit will remain in the 1st stage airflow profile and the fan will only operate up to 70% of the maximum output signal per user selection.

After the minimum 3 minute inter-stage timer has expired from the compressor 1 output being energized, the RTRM will energize the compressor 2 output if requested, and will shift the airflow profile vertically into the 2nd stage airflow profile until the call reduces to Stage 1.

The unit will stage down compressors and modulate the economizer back to minimum position in the reverse order that they were staged and the supply fan will follow the unit mode transitions based on the defined airflow profiles. Once the supply fan is no longer requested ON after a cooling call is cleared, the supply fan will remain energized at low speed for 160 seconds.

**Compressor Protection**

Special handling of the compressor protection inputs on the RTRM is necessary for this unit due to the dual capacity



compressor. The compressor 1 proving and disable inputs will be honored and the associated counters incremented when the inputs go active. Once active, both compressor outputs on the RTRM will be de-energized and inhibited from running until the fault clears. The compressor 2 disable input will be honored so customers can disable the high stage operation of the compressor if desired. No compressor operation will be locked out based on compressor 2 disable events.

The evaporator defrost control scheme will be initiated at an OA temperature of 55°F.

### Outdoor Fan Control

This unit control scheme will require no changes in existing outdoor fan control logic for ReliaTel™. The unit design currently only supports a single outdoor fan so the outdoor fan B output from the RTRM will be utilized.

### Economizer Min Position Handling (w/o DCV)

Economizer minimum positions will be handled similarly to how they are handled on other multi-speed indoor fan units.

The following setpoint potentiometers will be used on the RTEM:

- Design min at min fan speed PWM command (RTEM DCV min)
- Design min at medium fan speed PWM command (RTEM DCV setpoint LL)
- Design min at max fan speed PWM command (RTEM design min)

The controller will calculate the active OA damper minimum position linearly between the user-selected setpoints based on the supply fan speed command. The range for RTEM DCV Min and RTEM DCV Setpoint LL setpoints will be 0 to 100% while the range for the RTEM Design Min setpoint will be 0 to 50%.

As the supply fan speed ramps between its minimum and maximum output signal (based on cooling or heating modes/steps), the active economizer minimum position target will be calculated in a linear fashion, similarly to the OA CFM compensation function, in order to help maintain a constant OA flow through the unit and not over/under-ventilate.

### Demand Controlled Ventilation

DCV for this unit control will require an additional module (RTVM) for the three additional setpoint potentiometers necessary with the varying supply fan speed. The basic control strategy integrates two existing functions which on traditional units are mutually exclusive: OA CFM compensation and DCV.

**Note:** For all DCV operation, the supply fan will remain at minimum speed unless requested higher for heating or cooling operation.

This new scheme will require the setting of five OA damper position setpoints. This is three more than on traditional units which will be located on the required RTVM:

- Design Min Position @ Min Fan Speed PWM Command (RTVM R130)
- Design Min Position @ Medium Fan Speed PWM Command (RTVM R136)
- Design Min Position @ Max Fan Speed PWM Command (RTEM Design Min Position)
- DCV Min Position @ Min Fan Speed PWM Command (RTVM R41)
- DCV Min position @ Max Fan Speed PWM Command (RTEM DCV Min Position)

As the supply fan speed tracks between the minimum and maximum percent of the user selected setpoint, the active building design and DCV minimum positions will be calculated linearly between the user selected setpoints. These will be used to determine the active OA damper position target based on the space CO<sub>2</sub> level in relation to the design and DCV CO<sub>2</sub> setpoints.

### Dynamic Power Exhaust Setpoint

For units with a PWM controlled supply fan, the user will select an exhaust enable setpoint during the 100% fan speed command. Once selected, the difference between the exhaust enable setpoint and design OA damper minimum position at 100% fan speed will be calculated. The difference calculated will be used as an offset to be added to the active building design OA minimum position target to calculate the dynamic exhaust enable target to be used throughout the supply fan speed/OA damper position range.

### Ventilation Override Mode

During ventilation override modes in which the supply fan is commanded to run, the RTRM supply fan output will be energized and the PWM signal provided by the RTOM will correspond to 100% of the high speed selection.

### Dehumidification Control

Units configured with a PWM controlled indoor fan and a two-speed compressor will utilize two forms of dehumidification: Normal staged, hot gas reheat dehumidification and enhanced dehumidification without reheat.

### Enhanced Dehumidification

Enhanced dehumidification (EDh) will be available on all units equipped with a space humidity (SH) sensor, regardless of whether the unit is configured with traditional hot gas reheat (HGRH).

EDh will be accomplished on these units by utilizing a SH sensor and selecting a dehumidification setpoint (DhSp) on the RTOM and allowing ReliaTel™ to determine when there is a need for dehumidification. Once the SH value exceeds the DhSp and dehumidification is enabled the unit will energize one stage of compressor operation at 80% of the maximum stage 1 airflow rating.

As with traditional HGRH, EDh will override the request for 1st stage of cooling, but if there is a request for the 2nd



stage of cooling, EDh will be disabled. If the cooling request drops back below Cool 2, the unit will transition back into EDh if the dehumidification call is still present. If the dehumidification call is no longer present, the unit will transition into Cool 1 and track back into the Stage 1 airflow profile.

If during active EDh the SH falls below the DhSp - 2%, dehumidification will be terminated and the unit will transition back to normal cooling or heating control. Once EDh terminates and there is no request for heating, cooling, or ventilation, there will be a 60 second supply fan off delay in which the supply fan will continue to run at the EDh speed.

### Traditional Dehumidification with Hot Gas Reheat

Traditional dehumidification with HGRH will also be a supported option for this unit type. Units with this option will include a reheat coil as on traditional dehumidification units and will be controlled like a true two-compressor system.

Units configured with a traditional HGRH coil will utilize EDh as described above as the first stage of dehumidification control if the SH is only marginally high. If the unit is running in EDh and the SH drops below the DhSp, EDh will be terminated and the unit will transition out of the mode as described above. If the unit is operating in EDh and the SH is not recovering toward the DhSp, the unit will transition into full HGRH until the SH falls below the SH setpoint.

During HGRH dehumidification both compressor outputs will be energized simultaneously for full capacity operation and the supply fan will be at the user selected maximum speed. All existing overrides and functional operations for dehumidification will function as on units not configured for PWM signal fan speed control. Note that a 60 second supply fan off delay in which the supply fan will continue to run at the user selected maximum speed will also be implemented.

For units configured with traditional HGRH, SH and Humidistat operations will be supported. However, only units equipped with a SH sensor will utilize EDh as the first step of dehumidification control. If the unit is configured for HGRH under humidistat control, only full HGRH dehumidification will be utilized; normal dehumidification rules will be in effect for these units.

### Service Test

For these units, troubleshooting of the motor control can be performed by using the standard service test mode as is currently offered on ReliaTel™ controlled units. Refer to the following table for details about the fan speeds associated with each step of service test:

**Table 20. Service test**

| Test Step           | PWM Output <sup>(a)</sup> |
|---------------------|---------------------------|
| Fan On              | 50%                       |
| Econ <sup>(b)</sup> | 50%                       |

**Table 20. Service test (continued)**

| Test Step                       | PWM Output <sup>(a)</sup> |
|---------------------------------|---------------------------|
| Cool 1                          | 82%                       |
| Cool 2                          | 100%                      |
| Heat 1                          | 100%                      |
| Heat 2                          | 100%                      |
| Dehumid / Reheat <sup>(c)</sup> | 100%                      |

<sup>(a)</sup> The PWM output is in reference to the user selected maximum unit fan speed.

<sup>(b)</sup> Regardless of the economizer mode configuration, the unit will run the supply fan at the minimum speed during the economizer step of service test.

<sup>(c)</sup> Units with enhanced dehumidification only will not perform this step during service test.

### Failure and Override Modes

- **Supply fan proving** - If there is a supply fan failure condition all outputs associated with the supply fan output control will be de-energized and the PWM output will be at 0%.
- The supply fan will energize at high speed as a result of all failure modes that require the supply fan to operate.

## Single Zone VAV

ReliaTel™ controls platform will support single zone VAV (SZVAV) as an optional unit control type in order to meet ASHRAE 90.1 in addition to other multi-speed indoor fan configurations. Basic control will be a hybrid VAV configured unit that provides discharge temperature control to a varying discharge air temperature setpoint based on space temperature. Concurrently, the unit will control and optimize the supply air fan speed to maintain the zone temperature (ZT) to a zone temperature setpoint.

### Supply Fan Output Control - VFD Equipped Units

Normal SZVAV units will be equipped with a VFD controlled supply fan. The fan is controlled via the 0-10 Vdc RTOM J11-2 and the RTRM J1-11. The control will scale the output from the RTOM to adjust between the minimum and maximum range of the VFD.

### Direct Drive Backwards Curve Plenum Fan Equipped Units

For SZVAV units configured with an BC plenum (Precedent™), the control outputs a 2.4-7.6 Vdc signal from the RTOM J11-2 to cover the range of the application designed airflow. This output is adjustable via the RTOM R136 pot for adjusting cfm/ton. The adjustable range for max speed output is from 3.4 Vdc at full counter-clockwise to 7.6 Vdc at full clockwise.

### PWM Controlled Motor Equipped Units

For SZVAV units configured with a PWM controlled motor, the duty cycle of the PWM signal will be controlled in order to vary the speed of the supply fan. The range of the duty

cycle for the PWM output will be 50 to 100% of user selected maximum.

### Supply Fan Mode Operation

SZVAV units will utilize supply fan mode selection using ReliaTel™ controls for normal zone control and will be selectable between AUTO and ON via a connected zone sensor module or through BAS/Network controllers.

### Ventilation Control

Units configured for SZVAV control will require special handling of the OA damper minimum position. Refer to each section below for details on each configurable ventilation control method.

### Demand Controlled Ventilation

Units configured with DCV will invoke a new scheme which allows variable building design and DCV minimum positions and OA damper position target setpoints based on the supply fan speed and space CO<sub>2</sub> requirements.

This new scheme will require the setting of five OA damper position setpoints which will be located on the required RTVM:

- Design Min Position @ Min Fan Speed Command (RTVM R130)
- Design Min Position @ Medium Fan Speed Command (RTVM R136)
- Design Min Position @ Max Fan Speed Command (RTEM Design Min Position)
- DCV Min Position @ Min Fan Speed Command (RTVM R41)
- DCV Min position @ Max Fan Speed Command (RTEM DCV Min Position)

As the supply fan speed varies between 0 to 100%, the building design and DCV minimum position targets will be calculated between the user selected setpoints based on the instantaneous supply fan speed. The building design and DCV minimum position targets will be used to calculate the active OA damper minimum position target, based on the space CO<sub>2</sub> relative to the Design and DCV CO<sub>2</sub> setpoints.

The range for the design minimum and DCV minimum OA damper position setpoints at minimum and medium be 0 to 100%, while the range at maximum fan speed will be 0 to 50%.

### Outside Air Damper Minimum Positions without DCV

For units not configured with DCV, additional minimum position setpoints to increase outdoor airflow accuracy will be required. The operation will be similar to OA CFM compensation on traditional VAV units with the addition of a design minimum position setpoint at medium fan speed. The following setpoint potentiometers will be used on the RTEM:

- Design Min at Min Fan Speed Command (RTEM DCV Min)
- Design Min at Medium Fan Speed Command (RTEM DCV Setpoint LL)
- Design Min at Max Fan Speed Command (RTEM Design Min)

The controller will calculate the active OA damper minimum position between the user-selected setpoints based on the supply fan speed command. The range for the design minimum setpoints at minimum and medium fan speed will be 0 to 100% while the range for the design minimum at maximum fan speed setpoint will be 0 to 50%.

### Dynamic Exhaust Enable Setpoint

For units configured with an exhaust fan, the new schemes implemented for economizer minimum position handling require changes to the existing exhaust enable setpoint control scheme in order to prevent over/under pressurization. The overall scheme will remain very similar to non-SZVAV units with exhaust enable setpoint control utilizing the user selected exhaust enable setpoint to calculate a dynamic exhaust enable setpoint.

### Discharge Air Setpoint

**Note:** ReliaTel™ controlled not user adjustable.

For occupied cooling, heating (modulating only), and dehumidification the unit will utilize a varying discharge air setpoint (DASP) that is calculated based on zone conditions. DASP will be used as the active control point for controlling cooling (DACSP), heating (DAHSP), and dehumidification capacity. In general, as the ZT rises above the zone cooling setpoint (ZCSP), DACSP will be calculated down and as the ZT falls below the zone heating setpoint (ZHSP), DAHSP will be calculated upward.

For cooling, heating, and reheat output control the DASP calculation will be limited between user selectable setpoints and will be calculated higher and lower based on ZT.

If the controller determines that a discharge air temperature higher than the user selected upper limit, or lower than the user selected lower limit, is required for space conditioning, then fan output will be increased.

### Economizer Cooling

#### Economizer Enabled for Cooling

Once the unit has a request for economizer cooling and the unit has met all the cool mode transition requirements, the economizer will open beyond minimum position in order to meet the calculated discharge air cooling setpoint (DACSP) value. If the economizer reaches 100% before DACSP falls below the DACSP lower limit (LL) and the air temperature is greater than the DACSP, the control will create a temporary DACSP LL that will be used to determine fan speed output control. The temporary DACSP will not be allowed to be less than the user selected DACSP LL. As DACSP falls below the temporary DACSP LL, the supply

fan speed will be increased proportionally up to 100% as necessary.

Once the supply fan speed reaches 100% with the economizer at 100% for 3 minutes (5 if non V-3), compressors will be allowed to energize to meet the calculated DACSP value as necessary. Once compressors have been energized, the supply fan speed and economizer will be forced to 100%.

### Economizer Enabled to Disabled

If the unit is actively cooling with the economizer and then the economizer becomes disabled, the economizer will be closed to the active minimum position and compressors will be allowed to stage. At the point in which the economizer becomes disabled, the temporary DACSP LL will be set back to the user selected DACSP LL. The supply fan speed will be adjusted accordingly based on active cooling stage and DACSP value.

### Economizer Disabled to Enabled

If compressors are energized for cooling and the economizer was disabled, but becomes enabled, the economizer and supply fan speed will be forced to 100%.

## Compressor (DX) Cooling

### Cooling Sequence

If the control determines that there is a need for active cooling capacity in order to meet the calculated DACSP, once supply fan proving has been made, the unit will begin to stage compressors accordingly.

Once the DACSP calculation has reached its bottom limit and compressors are being utilized to meet the demand, as the DACSP value continues to calculate below the DACSP LL, the supply fan speed will begin to ramp up toward 100%.

As the cooling load in the zone decreases, the compressors begin to de-energize and the supply fan will fall back to the cooling stage's associated minimum speed.

### Cooling Stages Minimum Fan Speed

As the unit begins to stage compressors to meet the cooling demand, the following minimum supply fan speeds will be utilized for each corresponding cooling stage.

**Table 21. Minimum supply fan speeds**

| Unit Mode              | VFD, BC Plenum, non-17 SEER Minimum Fan Speed | WHC/DHC/17 SEER Minimum Fan Speed |
|------------------------|---|-----------------------------------|
| Fan Only               | 33%   | 57%                               |
| Economizer Cooling     | 33%   | 57%                               |
| Stage 1                | 33%   | 57%                               |
| Stage 2                | 50%   | 82%                               |
| Stage 3 (if available) | 50%   | 82%                               |

## Mode Transitions

Auto-Changeover - The following auto-changeover rules will be implemented:

- At power-up, when the local unit mode is set to Auto, or after a unit reset, the active unit mode is set to Heat if the active ZT < CSP, or Cool if the active ZT > CSP.
- If the active unit mode is Cool, the active unit mode is switched to Heat when both the active ZT < HSP and it has been 5 minutes since last active call for cooling was terminated.
- If the active unit mode is Heat, the active unit mode is switched to Cool when both the active ZT > greater of CSP and [HSP + 3 F] and it has been 5 minutes since last active call for heating was terminated.

## Occupied Heating Operation

Occupied heating operation on units configured with SZVAV control will utilize two separate control methodologies based on heating configurations.

### Staged Heating Operation

For units configured with staged heat once a request for active heating capacity has been determined and the unit has met all auto-changeover requirements, the unit will energize the supply fan and ramp up to full speed. Heating stages will be energized/de-energized to meet the zone heating demand.

### Modulating Heat Operation with SZVAV Heating

Units configured with a modulating heat type will utilize true SZVAV control. DAHSP will be used in order to determine heating capacity demand and a fan speed.

### Heating Sequence

Once the unit has met all auto-changeover requirements and the unit is requesting active heating capacity (ZT < ZHSP) the unit will transition into zone heating.

Once the DAHSP calculation has reached its Upper Limit (UL) and the modulating heat output is being utilized, the supply fan speed will begin to ramp up toward 100%. Note that the supply fan speed will remain at the minimum value until the DAHSP value is calculated above the DAHSP UL.

As the heating load in the zone decreases the fan speed will decrease down to minimum and the heat output will modulate as necessary. As the load in the zone continues to drop the fan speed will be maintained at this minimum airflow and the algorithm will continue to calculate the DASP down toward the zone neutral state (ZHSP < DASP < ZCSP) and control the mod. heat output accordingly. Once the modulating heat output reaches 0% and the heating demand in the space is satisfied, the unit will de-energize all heating outputs.

### Modulating Heat Operation with Traditional Constant Volume Fan Operation

Units configured with a modulating heat type will also support a user configurable input to select traditional constant volume (TCV) heating control. The RTOM modulating heat 1st input will be utilized for this configuration.

If configured to utilize TCV, the unit will perform normal heating control utilizing full airflow and a modulating heat output.

### Supply Air Tempering Operation

Supply air tempering operation on units configured with SZVAV control will utilize two separate control methodologies based on heating configurations.

For all staged heating types, the unit will utilize the same supply air tempering scheme as is used on TCV units.

For units configured with a modulating heat type and for true SZVAV heating, tempering is an extension of normal heating control which allows a transition from auto-cool mode to heating based on discharge temperature if the ZT is in control. The following conditions must be true to allow the unit to enter supply air tempering:

- Supply Fan is ON.
- Unit is in occupied mode.
- Unit is operating in auto-cool mode.
- Cooling has been inactive for 5 minutes.
- Unoccupied cooling and heating operation.

For SZVAV controlled units, the unit will control during unoccupied periods using the heating and cooling SZVAV algorithm. The following will be true during unoccupied periods:

- Unit will utilize setback/modified zone setpoints.
- Minimum OA damper position will be overridden to 0.
- Fan mode will be overridden to Auto as on normal CV units.

### Dehumidification Operation

SZVAV units will support both traditional staged and modulating dehumidification configurations. Most functions will be identical to traditional dehumidification control.

#### Modulating Dehumidification (27.5 to 50 Tons) - Entering Dehumidification

At startup a ZT value greater than the active ZCSP, or below the active ZHSP, will prevent dehumidification operation. At this point the unit will perform normal sensible cooling or heating control until the respective setpoint is satisfied.

After startup, the unit will monitor the space humidity (SH), OA temperature, ZT, and unit status to determine when to enter and leave dehumidification mode. As long as the unit

is not actively heating or cooling with more than half the mechanical cooling capacity or the unit is not disabled, it will enter dehumidification mode when there is a call for dehumidification.

When dehumidification mode is entered the unit will:

- Energize the supply fan, if not already ON, and ramp the fan speed up to 80% airflow.
- Stage up all compressors with approximately 2 seconds between stages.
- Command the OA damper to minimum position.
- The supply air reheat setpoint will be mapped to the active maximum SZVAV heat setpoint which will be the maximum value of DASP during active reheat.
- Begin to control the reheat valve and cooling valve to maintain the discharge air temperature to meet the DASP.

Once the unit is actively dehumidifying, DASP will continue to calculate and will be used as the supply air reheat setpoint that the cooling and reheat valves will be modulated to meet. The user adjustable supply air reheat setpoint will be used as an UL for DASP during active dehumidification and will be limited to the normal range of 65-80°F.

### Leaving Dehumidification

On a call to leave dehumidification mode the unit will perform the following:

- Mechanical cooling will stage back to 50% of the available capacity then will be released to normal SZVAV control to meet the load demand.
- The economizer will be released to normal control.
- The supply fan will ramp down to minimum speed.
- The cooling valve will be driven to 100% and the reheat valve will be driven to 0%.
- The reheat pumpout relay will be energized if the reheat circuit is requested or de-energized if the reheat circuit de-energizes.

### Staged (On/Off) Dehumidification w/HGRH for Non-17 SEER SZVAV

#### Dehumidification Transitions (Zone Overrides)

At startup, a ZT value greater than the ZCSP, or below the ZHSP, will prevent dehumidification operation. At this point the unit will perform normal sensible cooling or heating control until the respective setpoint is satisfied. Once the zone is satisfied and there are no other overrides in effect, the following transition rules shall be followed:

If  $(HSP+1^{\circ}F) < ZT < (CSP+1^{\circ}F)$  and less than 50% available mechanical cooling capacity is energized, then dehumidification is enabled and the following actions will be performed when transitioning into Cool+Reheat:

1. Energize the supply fan, if not already ON, and ramp the fan speed up to 80% airflow for VFD, BC plenum, and non-17 SEER PWM controlled supply fan units.

2. Stage up all compressors with approximately 2 seconds between stages.
3. Energize the reheat solenoid.
4. Command the OA damper to minimum position.

If  $ZT < (HSP+0.5^{\circ}F)$  or  $ZT > (CSP+1^{\circ}F)$ , or  $ZT < (CSP+1^{\circ}F)$  with more than 50% available mechanical cooling capacity energized, then dehumidification is disabled and the following actions will be performed when transitioning out of Cool+Reheat:

- If  $ZT > (CSP+1^{\circ}F)$ , stage back to Cool 1 in normal SZVAV cooling
- If  $ZT < (HSP+0.5^{\circ}F)$ , leave reheat, de-energize all compressors and allow the unit to transition into heat/cool mode based on ZT.
- If  $ZT > (CSP-0.5^{\circ}F)$  and  $SH < \text{Dehumidification Setpoint (DhSp)} - 5\%$ , stage back to Cool 1 and wait 3 minutes.
- If  $ZT < (CSP - 0.5^{\circ}F)$  and  $SH < \text{DhSp} - 5\%$ , leave reheat, de-energize all compressors and allow the unit to transition into heat/cool mode based on ZT.

### Staged Dehumidification with HGRH and Enhanced Dehumidification for 17 SEER SZVAV

Enhanced dehumidification - 17 SEER SZVAV units will perform enhanced dehumidification (EDh) in all cases in which the unit is equipped with a SH sensor or a valid SH value is being communicated from a BAS and the active DhSp is less than the active SH value.

Dehumidification transitions for 17 SEER enhanced dehumidification - At start-up, a ZT value greater than the active ZCSP, or below the active ZHSP will prevent dehumidification operation. At this point the unit will perform normal sensible cooling or heating control until the respective setpoint is satisfied. Once the zone is satisfied and there are no other overrides in effect, the following transition rules shall be followed:

If  $(HSP+1^{\circ}F) < ZT < (CSP+1^{\circ}F)$  and  $SH > \text{DhSp}$  and the unit is operating at Stage 1 or less of compressor cooling, then EDh is enabled and the unit will perform the following:

1. Energize the supply fan, if not already ON, and ramp the fan speed output to 56% airflow.
2. Energize stage 1 of the compressor operation.
3. Command the OA damper to minimum position.

If  $ZT > (HSP+0.5^{\circ}F)$  or  $ZT > (CSP+1.5^{\circ}F)$  or  $SH < \text{DhSp} - 2\%$ , then EDh is disabled and the unit will perform the following when transitioning out of EDh:

Stage back to normal SZVAV cooling if  $ZT > (CSP+1.5^{\circ}F)$ .  
Fall back to SZVAV cooling control with stage 1 compressor operation energized and initialize DASP Fan control to normal cooling operation.

Stage back to normal control:

- If  $ZT < (HSP+0.5^{\circ}F)$ , leave dehumidification and de-energize all compressor outputs immediately and allow

the unit to transition into heat/cool mode based on ZT. Release fan control and initialize DASP based on active unit mode.

- If  $ZT > (CSP-0.5^{\circ}F)$  and  $SH < \text{DhSp} - 2\%$ , stage back to Cool 1 and initialize DASP to active DAT.
- If  $ZT < (CSP-0.5^{\circ}F)$  and  $SH < \text{DhSp} - 2\%$ , leave reheat, de-energize all compressors immediately and allow the unit to transition into heat/cool mode based on ZT. Initialize DASP based on active unit mode.

If no request for active heating/cooling or fan operation is present, the supply fan will remain energized at 56% for 60 seconds after the compressor de-energizes.

### Enhanced Dehumidification + Staged (On/Off) HGRH

For 17 SEER SZVAV, the option will be available to have traditional staged dehumidification with hot gas reheat (HGRH) in addition to EDh. A valid SH value will be required, and the unit will need to be hardwired configured for Reheat (RTOM J9-2) and the non-heat pump configuration will need to be OPEN (RTRM J1-5) in order to use the RTRM J2-7 output for reheat operation

### Dehumidification Transitions for Enhanced Dehumidification + Staged HGRH

Units configured for traditional HGRH will utilize EDh as described above as the first stage of dehumidification control if the SH is only marginally high ( $\text{DhSp} < SH < \text{DhSp} + 2\%$ ). If the unit is running in EDh and the SH drops to  $> \text{DhSp} - 2\%$ , EDh will be terminated and the unit will transition out of the mode as described above. If the unit is operating in EDh and the SH is not recovering toward the  $\text{DhSp} - 2\%$ , the unit will transition into full HGRH until the SH falls below the  $\text{DhSp} - 5\%$ . If at any time the SH value rises above the  $\text{DhSp} + 2\%$ , the unit will also transition into full HGRH until the SH falls below the  $\text{DhSp} - 5\%$ .

The mode transition details into full HGRH, as described above for EDh, will be in effect for 17 SEER units with HGRH when only EDh is being utilized. However, if the unit is utilizing full HGRH, the following transitional details will be enforced:

If  $\text{DhSp} < SH < \text{DhSp} + 2\%$  and the SH is not recovering toward the  $\text{DhSp} - 2\%RH$  or, if the SH value rises above the  $\text{DhSp} + 2\%$ , or if the humidistat input is active, then the unit will transition into full HGRH if  $(HSP+1^{\circ}F) < ZT < (CSP+0.5^{\circ}F)$  and the unit is operating at Stage 1 of compressor cooling. The unit will perform the following when transitioning into HGRH:

1. Energize the supply fan, if not already ON, and ramp the fan speed up to 100% of the application airflow.
2. Energize stage 1 and stage 2 of the compressor operation with the reheat solenoid.
3. Command the OA damper to minimum position.

If  $SH < \text{DhSp} - 5\%$  or  $ZT < (HSP+0.5^{\circ}F)$  or  $ZT > (CSP+1^{\circ}F)$  or  $ZT < (HSP+0.5^{\circ}F)$  and the unit is operating at  $> \text{Stage 1}$  of compressor operation, then HGRH is disabled. The unit

## Single Zone VAV, Multi-Speed, and 17 Plus

will perform the following when transitioning out of HGRH. Stage back to normal SZVAV cooling:

- If  $ZT > (CSP + 1^{\circ}F)$ , stage back to Cool 1, de-energize the solenoid, release fan control and initialize DASP to active DAT after a 3 minute delay.

Stage back to normal control:

- If  $ZT < (HSP + 0.5^{\circ}F)$ , leave dehumidification, de-energize all compressor outputs and the reheat solenoid immediately, and allow the unit to transition into heat/cool mode based on ZT. Initialize DASP based on active unit mode and release fan control.
- If  $ZT > (CSP - 0.5^{\circ}F)$  and  $SH < DhSp - 5\%$ , stage back to Cool 1, de-energize the reheat solenoid, and initialize DASP to active DAT after a 3 minute delay.
- If  $ZT < (CSP - 0.5^{\circ}F)$  and  $SH < DhSp - 5\%$ , leave reheat, de-energize all compressors immediately, and allow the unit to transition into heat/cool mode based on ZT. Initialize DASP based on the active unit mode.

If no request for active heating/cooling or fan operation is present, the supply fan will remain energized at 100% for 60 seconds after the compressor de-energizes.

### Dehumidification Overrides

Sensible cooling or heating control overrides dehumidification control. Any heating request will terminate dehumidification control. If heating is active at the time a call for dehumidification control is received the heating operation must complete and an additional 5 minutes from the time heat is terminated must elapse before dehumidification will be allowed.

### Purge Mode (Comfort and Dehumidification)

Purge cycle operation will operate identically to purge on non-SZVAV dehumidification units. If the reheat circuit operates in one mode (dehumidification or cooling) for a cumulative 90 minutes the unit will initiate a 3-minute purge cycle exactly as on non-single zone VAV units with staged dehumidification.

During an active purge cycle the supply fan speed will operate at the appropriate speed based on the active compressor step. If a dehumidification purge is initiated, the unit will run at appropriate dehumidification airflow and if performing a cooling purge, the supply fan will track based on the appropriate minimum speed for the

associated number of compressors energized. After the purge cycle is complete, the supply fan will be released to normal control based on the cooling/dehumidification demand.

### Dehumidification - Humidistat Operation

For SZVAV units configured with modulating dehumidification and are utilizing a humidistat for control, the unit will function as described above, but instead of making an internal decision when to perform dehumidification based on a SH value, the unit will take requests for dehumidification from the humidistat input. If the humidistat input goes active and all conditions described above are met to allow dehumidification, the unit will enter dehumidification as described in entering dehumidification above. All other normal overrides will be in effect. Once the humidistat input is inactive, the unit will transition out of dehumidification as described above in leaving dehumidification.

### Other Considerations

- Any heating request will terminate dehumidification control. If heating is active at the time a call for dehumidification control is received, the heating operation must complete and an additional 5 minutes from the time heat is terminated must elapse before any form of dehumidification will be allowed.
- Enhanced dehumidification will not be available with a humidistat. Fully hot gas reheat will be available with a humidistat.

### Variable Speed (VSPD) Compressor Control (eFlex™)

#### Unit Operation

The following sections describe hardware output requirements as well as unit control sequence of operations.

#### Compressor Requirements

For ReliaTel™ systems, the VSPD compressor will require two signals for proper control:

- Run/Start-Stop command (VSM binary output)
- Speed signal (VSM analog output)

**Table 22. Normal run - 3 to 5 ton units**

| Model | Running Frequency |        | Voltage Range |      | SZVAV Supply Fan Speed |             | MZVAV Supply Fan Speed |             |
|-------|-------------------|--------|---------------|------|------------------------|-------------|------------------------|-------------|
|       | Min Hz            | Max Hz | Min           | Max  | Min-Min PWM            | Max-Min PWM | Min-Min PWM            | Max-Min PWM |
| 3     | 15                | 60     | 2.4           | 5.7  | 53                     | 80          | 53                     | 80          |
| 4     | 15                | 60     | 2.4           | 5.7  | 53                     | 80          | 53                     | 80          |
| 5     | 15                | 62     | 2.4           | 5.85 | 53                     | 80          | 53                     | 80          |

**Table 23. Normal run - 6 to 10 ton units**

| Model | Variable Speed Compressor |                |         |         | SZVAV Supply Fan Speed |           | MZVAV Supply Fan Speed |           |
|-------|---------------------------|----------------|---------|---------|------------------------|-----------|------------------------|-----------|
|       | Freq. Min (Hz)            | Freq. Max (Hz) | VDC Min | VDC Max | Min-Min V              | Max-Min V | Min-Min V              | Max-Min V |
| 6     | 17                        | 82             | 1.42    | 6.83    | 50                     | 82        | 50                     | 82        |
| 7.5   | 22                        | 63             | 1.83    | 5.25    | 50                     | 82        | 50                     | 82        |
| 8.5   | 22                        | 68             | 1.83    | 5.67    | 50                     | 82        | 50                     | 82        |
| 10    | 22                        | 80             | 1.83    | 6.67    | 50                     | 82        | 50                     | 82        |

**Table 24. Normal run - 12.5 to 17.5 tons**

| Model    | Variable Speed Compressor |                |         |         | SZVAV Supply Fan Speed |           | MZVAV Supply Fan Speed |           |
|----------|---------------------------|----------------|---------|---------|------------------------|-----------|------------------------|-----------|
|          | Freq. Min (Hz)            | Freq. Max (Hz) | VDC Min | VDC Max | Min-Min V              | Max-Min V | Min-Min V              | Max-Min V |
| Fan Only | 0                         | 0              | 0       | 0       | 1.6                    | 1.6       | 1.6                    | 1.6       |
| 12.5     | 15                        | 75             | 2.4     | 6.8     | 1.6                    | 7.6       | 1.6                    | 7.6       |
| 15       | 15                        | 70             | 2.4     | 6.36    | 1.6                    | 7.6       | 1.6                    | 7.6       |
| 17.5     | 15                        | 75             | 2.4     | 6.36    | 1.6                    | 7.6       | 1.6                    | 7.6       |

**Economizing Supply Fan Speeds on VSPD Compressor Configured Units**

This section covers expected supply fan (indoor fan) speeds during economizing-only based cooling efforts. When economizing is available and economizing-based cooling efforts are able to meet cooling demands without staging up compressor-based cooling, compressor operation is inhibited.

When a call for cooling exceeds the available cooling capacity that can be provided by the economizing-based cooling alone, compressor based cooling operation may be leveraged. When compressors are enabled, the required minimum supply fan speeds for compressor-based cooling have priority over supply fan speeds covered in this subsection.

The DX inhibited (compressors off) economizing supply fan speeds for all supported eFlex™ variable speed compressors are to be as defined in the following table below.

**Table 25. Fan speeds**

| ReliaTel™ Product Family  | Tons            | Supply Fan Control Type (s): | Economizing Active Supply Fan Speed (with DX Cooling Inhibited): |
|---------------------------|-----------------|------------------------------|--|
| Precedent™                | 3, 4, 5         | SZVAV and MZVAV              | 53% Airflow (PWM Duty Cycle: 53%)                                |
| Precedent™                | 6, 7.5, 8.5, 10 | SZVAV and MZVAV              | 50% Airflow (0-10 Vdc signal: 50%)                               |
| Voyager™-Light Commercial | 12.5, 15, 17.5  | SZVAV and MZVAV              | 37% Airflow (VFD Command: 1.6 Vdc)                               |

**Ventilation Supply Fan Speeds on VSPD Compressor Configured Units**

This section covers expected supply fan (indoor fan) speeds during active ventilation efforts. Active ventilation supply fan speeds for all supported eFlex™ variables speed compressors are to be as defined in the following table below:

**Table 26. Supply fan speeds**

| ReliaTel™ Product Family  | Tons           | Supply Fan Control Type (s) | Active Ventilation Supply Fan Speed (with no active call for cooling/heating/dehumidification) |
|---------------------------|----------------|-----------------------------|--|
| Precedent™                | 3, 4, 5        | SZVAV and MZVAV             | 53% Airflow (PWM Duty Cycle: 53%)  |
| Voyager™-Light Commercial | 12.5, 15, 17.5 | SZVAV and MZVAV             | 37% Airflow (VFD Command: 1.6 Vdc)   |

**Note:** The above required supply fan speeds are the expected speeds while there is only a call for ventilation, and no calls for cooling, heating or dehumidification. When cooling, heating or dehumidification calls exist, the required fan speeds have priority over the supply fan speeds documented in this section.

### Multi-Zone VAV Cooling (Traditional VAV)

#### Occupied DX and Economizing Cooling Control

For normal cooling operation, the total cooling capacity will be modulated in order to meet the user selected discharge air cooling setpoint (DACSP).

If enabled, economizer cooling will be utilized as the first stage of cooling prior to energizing the DX capacity. Economizer cooling will modulate the outdoor air (OA) damper to maintain the DACSP - as on standard fixed speed compressor equipped units.

Once all economizing requirements have been met, compressor operation will be enabled if the economizer alone cannot meet the demand. Once compressor operation is started, the VSPD compressor will startup, following all startup requirements, and will then be modulated to maintain the discharge air temperature to the DACSP.

For Voyager™ light commercial units, if there is additional demand for cooling once the VSPD compressor has reached its maximum speed for Stage 1, the controller will energize the first fixed speed compressor on circuit 2. Once the first fixed speed compressor is energized, the VSPD compressor speed will be reduced to its minimum speed for Stage 2 of compressor operation and then will be released back to discharge air temperature control. This process will be repeated for the transition between Stages 2 and 3.

Once the active cooling demand has been satisfied for Voyager™ light commercial units, compressors will begin staging down in reverse order from the stage up sequence. Once the VSPD compressor has reached its minimum speed for any given stage of cooling, if the cooling demand continues to decrease, the last fixed speed compressor to energize will be de-energized. Once a fixed speed compressor is de-energized, the VSPD compressor will be increased to its maximum value for the active stage of compressor operation and will then be released back to normal control. After the unit has staged down all fixed compressors, then only the VSPD compressor will be left operating and the following information applies to both Voyager™ light commercial and Precedent™ units: Once there is no longer a demand for the VSPD compressor, the VSPD compressor will modulate down to its minimum speed and then will be de-energized, while adhering to all shutdown requirements. Once all compressors have de-energized, the economizer, if enabled, will be allowed to close back to minimum position if there is no longer a demand.

**Note:** *In all cases, during normal compressor operation, the VSPD compressor will be subject to a 3-minute minimum on/off time and the supply fan will continue to be controlled by the supply air pressure.*

#### Unoccupied DX and Economizer Cooling Control

For unoccupied DX and economizer cooling control, the unit will operate as a standard fixed-speed compressor unit<sup>1</sup>. During all requests for cooling operation during unoccupied mode, the unit will operate the VSPD compressor at 100% of the available capacity<sup>2</sup>. When compressor operation is requested, the VSPD compressor will be started first and its speed will be increased up to 100%, based on the unit configuration. In the case of the multi-compressor unit, the VSPD compressor alone cannot meet the space demand; the unit will begin to stage up additional compressors to meet the demand.

**Note:** *Light commercial units do not support unoccupied mode without a BAS system or programmable zone sensor to support the needed unoccupied heat/cool setpoints.*

*Demand limits, restricting available compressor capacity, are to have higher priority over the commanded compressor capacity staging level due to occupancy status.*

Dehumidification is not currently supported on multi-zone VAV.

#### Single Zone VAV Cooling - Supply Fan Output Signal Control

No new supply fan technology is required to support the VSPD compressor application, existing supply fan types will be utilized. While no new fan technology is required, a change will be required to optimize the unit control with a VSPD compressor. Modifications will be made to the minimum fan speed based on active compressor capacity.

### Discharge Air Temperature Control

#### Occupied DX and Economizer Cooling Control

For normal cooling operation, the total cooling capacity will be modulated and staged in order to meet the calculated DACSP, as standard fixed speed compressor units.

#### Unoccupied DX and Economizer Cooling Control

For unoccupied DX and economizer cooling control, the unit will operate as during normal occupied mode. Compressor capacity will be varied to maintain the discharge air temperature requirements and the supply fan will remain in control based on the active compressor capacity and space demand.

#### Enhanced Dehumidification

Enhanced dehumidification on ReliaTel™ SZVAV VSPD compressor units will use a slower minimum indoor fan



speed at a constant compressor stage to achieve dehumidification.

### Active Cooling Mode Operation

When the unit is in active cooling mode, the unit is allowed to enter enhanced dehumidification if space humidity is greater than the dehumidification setpoint and the zone temperature conditions are satisfied.

When the unit enters enhanced dehumidification, the compressor staging will be held at current conditions and fan will drop to the minimum speed operating range. Enhanced dehumidification will continue to run until space humidity is less than the dehumidification setpoint - 2% and the zone temperature is approaching either the cooling or heating setpoint.

### Idle Mode Operation

If unit is in idle mode and dehumidification conditions are met, the compressors and supply fan will be started to a predetermined point and run until the above termination conditions are met.

### Condenser Fan Control

For single compressor units with a VSPD compressor, the unit will also be equipped with a variable speed VSM condenser fan motor.

The condenser fan shall be controlled based on the following tables:

**Table 27. Condenser fan control data - 3 to 5 tons**

| OAT Condition | VSPD Comp. Speed        | 3T  |                 |            | 4T   |                 |            | 5T   |                 |            |
|---------------|-------------------------|-----|-----------------|------------|------|-----------------|------------|------|-----------------|------------|
|               |                         | RPM | % Cond. Airflow | Duty Cycle | RPM  | % Cond. Airflow | Duty Cycle | RPM  | % Cond. Airflow | Duty Cycle |
| OAT>95F       | Min<Hz<Max              | 894 | 100%            | 73%        | 1013 | 100%            | 84%        | 1076 | 100%            | 89%        |
| 45F<OAT<90F   | <23Hz                   | 383 | 40%             | 29%        | 473  | 40%             | 37%        | 524  | 40%             | 41%        |
|               | 25Hz<Hz<50Hz            | 691 | 70%             | 56%        | 743  | 70%             | 60%        | 800  | 70%             | 65%        |
|               | >52Hz                   | 894 | 100%            | 73%        | 1013 | 100%            | 84%        | 1076 | 100%            | 89%        |
| <40F          | Startup                 | 290 | 32%             | 21%        | 311  | 22%             | 23%        | 358  | 22%             | 27%        |
| 25F<OAT<40F   | Min<Hz<Max && ! Startup | 236 | 26%             | 16%        | 311  | 22%             | 23%        | 358  | 22%             | 27%        |
| OAT<20F       | Min<Hz<Max && ! Startup | 236 | 26%             | 16%        | 311  | 22%             | 23%        | 358  | 22%             | 27%        |

**Notes:**

1. A 2 Hz hysteresis around the VSPD compressor speed will be implemented when transitioning from high speed to low speed.
2. 17.5 VDC x Duty Cycle % = Est. Speed Command

**Table 28. Condenser fan control data - 6 to 10 tons**

| OAT Condition | VSPD Comp. Speed | 6 Tons   |                 |            | 10 Tons  |                 |            |
|---------------|------------------|----------|-----------------|------------|----------|-----------------|------------|
|               |                  | RPM      | % Cond. Airflow | Duty Cycle | RPM      | % Cond. Airflow | Duty Cycle |
| OAT>95F       | Min<Hz<Max       | 1001     | 100             | 83%        | 1130     | 100%            | 94%        |
| 45F<OAT<90F   | <48Hz            | 473      | 40              | 31%        | 532      | 40%             | 37%        |
|               | 50Hz<Hz<70Hz     | 733      | 70              | 56%        | 831      | 70%             | 65%        |
|               | >72Hz            | 1001     | 100             | 83%        | 1130     | 100%            | 94%        |
| 25F<OAT<40F   | Min<Hz<Max       | 312      | 22              | 16%        | 352      | 22%             | 20%        |
| OAT<20F       | Min<Hz<Max       | 312      | 22              | 16%        | 352      | 22%             | 20%        |
| OAT Condition | VSPD Comp. Speed | 7.5 Tons |                 |            | 8.5 Tons |                 |            |
|               |                  | RPM      | % Cond. Airflow | Duty Cycle | RPM      | % Cond. Airflow | Duty Cycle |
| OAT>95F       | Min<Hz<Max       | 1111     | 100%            | 92%        | 1116     | 100%            | 92%        |
| 45F<OAT<90F   | <23Hz            | 465      | 40%             | 31%        | 465      | 40%             | 31%        |
|               | 25Hz<Hz<53Hz     | 790      | 70%             | 61%        | 790      | 70%             | 61%        |
|               | >55Hz            | 1111     | 100%            | 92%        | 1116     | 100%            | 92%        |
| 25F<OAT<40F   | Min<Hz<Max       | 300      | 22%             | 15%        | 300      | 22%             | 15%        |
| OAT<20F       | Min<Hz<Max       | 300      | 22%             | 15%        | 300      | 22%             | 15%        |

**Notes:**

1. A 2Hz hysteresis around the VSP compressor speed will be implemented when transitioning from high speed to low speed.
2. 17.5 VDC x Duty Cycle % = Est. Speed Command

## Single Zone VAV, Multi-Speed, and 17 Plus

**Table 29. Condenser fan control data - 6 to 10 tons**

| OAT Condition | VSPD Comp. Speed | 6 Tons   |                 |            | 10 Tons  |                 |            |
|---------------|------------------|----------|-----------------|------------|----------|-----------------|------------|
|               |                  | RPM      | % Cond. Airflow | Duty Cycle | RPM      | % Cond. Airflow | Duty Cycle |
| OAT>95F       | Min<Hz<Max       | 1001     | 100             | 83%        | 1130     | 100%            | 94%        |
| 45F<OAT<90F   | <48Hz            | 473      | 40              | 31%        | 532      | 40%             | 37%        |
|               | 50Hz<Hz<70Hz     | 733      | 70              | 56%        | 831      | 70%             | 65%        |
|               | >72Hz            | 1001     | 100             | 83%        | 1130     | 100%            | 94%        |
| 25F<OAT<40F   | Min<Hz<Max       | 312      | 22              | 16%        | 352      | 22%             | 20%        |
| OAT<20F       | Min<Hz<Max       | 312      | 22              | 16%        | 352      | 22%             | 20%        |
| OAT Condition | VSPD Comp. Speed | 7.5 Tons |                 |            | 8.5 Tons |                 |            |
|               |                  | RPM      | % Cond. Airflow | Duty Cycle | RPM      | % Cond. Airflow | Duty Cycle |
| OAT>95F       | Min<Hz<Max       | 1111     | 100%            | 92%        | 1116     | 100%            | 92%        |
| 45F<OAT<90F   | <23Hz            | 465      | 40%             | 31%        | 465      | 40%             | 31%        |
|               | 25Hz<Hz<53Hz     | 790      | 70%             | 61%        | 790      | 70%             | 61%        |
|               | >55Hz            | 1111     | 100%            | 92%        | 1116     | 100%            | 92%        |
| 25F<OAT<40F   | Min<Hz<Max       | 300      | 22%             | 15%        | 300      | 22%             | 15%        |
| OAT<20F       | Min<Hz<Max       | 300      | 22%             | 15%        | 300      | 22%             | 15%        |

**Note:** A 2Hz hysteresis around the VSP compressor speed will be implemented when transitioning from high speed to low speed.

**Table 30. Condenser fan control data - 12.5 to 17.5 tons**

| OAT Condition | VSPD Comp. Speed | Fixed  | Fixed  | 12.5 to 15 Tons |                 |                | 17.5 Tons |                 |                |
|---------------|------------------|--------|--------|-----------------|-----------------|----------------|-----------|-----------------|----------------|
|               |                  | Comp 1 | Comp 2 | RPM             | % Cond. Airflow | VSM Duty Cycle | RPM       | % Cond. Airflow | VSM Duty Cycle |
| OAT>95F       | <30Hz            | OFF    | OFF    | 1140            | 100%            | 95%            | 1080      | 100%            | 90%            |
| OAT>95F       | >30Hz            | OFF    | OFF    | 1140            | 100%            | 95%            | 1080      | 100%            | 90%            |
| OAT>95F       | <30Hz            | ON     | OFF    | 1140            | 100%            | 95%            | 1080      | 100%            | 90%            |
| OAT>95F       | >30Hz            | ON     | OFF    | 1140            | 100%            | 95%            | 1080      | 100%            | 90%            |
| OAT>95F       | <30Hz            | ON     | ON     | 1140            | 100%            | 95%            | 1080      | 100%            | 90%            |
| OAT>95F       | >30Hz            | ON     | ON     | 1140            | 100%            | 95%            | 1080      | 100%            | 90%            |
| 45F<OAT<90F   | <30Hz            | OFF    | OFF    | 533             | 45%             | 43%            | 530       | 45%             | 43%            |
| 45F<OAT<90F   | >30Hz            | OFF    | OFF    | 753             | 65%             | 62%            | 754       | 65%             | 62%            |
| 45F<OAT<90F   | <30Hz            | ON     | OFF    | 753             | 65%             | 62%            | 754       | 65%             | 62%            |
| 45F<OAT<90F   | >30Hz            | ON     | OFF    | 863             | 75%             | 71%            | 866       | 75%             | 72%            |
| 45F<OAT<90F   | <30Hz            | ON     | ON     | 863             | 75%             | 71%            | 866       | 75%             | 72%            |
| 45F<OAT<90F   | >30Hz            | ON     | ON     | 1140            | 100%            | 95%            | 1080      | 100%            | 90%            |
| 25F<OAT<40F   | <30Hz            | OFF    | OFF    | 309             | 25%             | 24%            | 303       | 25%             | 24%            |
| 25F<OAT<40F   | >30Hz            | OFF    | OFF    | 309             | 25%             | 24%            | 303       | 25%             | 24%            |
| 25F<OAT<40F   | <30Hz            | ON     | OFF    | 309             | 25%             | 24%            | 303       | 25%             | 24%            |
| 25F<OAT<40F   | >30Hz            | ON     | OFF    | 533             | 45%             | 43%            | 530       | 45%             | 43%            |
| 25F<OAT<40F   | <30Hz            | ON     | ON     | 533             | 45%             | 43%            | 530       | 45%             | 43%            |
| 25F<OAT<40F   | >30Hz            | ON     | ON     | 533             | 45%             | 43%            | 530       | 45%             | 43%            |
| OAT<20F       | <30Hz            | OFF    | OFF    | 250             | 20%             | 21%            | 245       | 20%             | 21%            |
| OAT<20F       | >30Hz            | OFF    | OFF    | 250             | 20%             | 21%            | 245       | 20%             | 21%            |
| OAT<20F       | <30Hz            | ON     | OFF    | 309             | 25%             | 24%            | 303       | 25%             | 24%            |
| OAT<20F       | >30Hz            | ON     | OFF    | 533             | 45%             | 43%            | 530       | 45%             | 43%            |
| OAT<20F       | <30Hz            | ON     | ON     | 533             | 45%             | 43%            | 530       | 45%             | 43%            |

**Table 30. Condenser fan control data - 12.5 to 17.5 tons (continued)**

| OAT Condition | VSPD Comp. Speed | Fixed  | Fixed  | 12.5 to 15 Tons |                 |                | 17.5 Tons |                 |                |
|---------------|------------------|--------|--------|-----------------|-----------------|----------------|-----------|-----------------|----------------|
|               |                  | Comp 1 | Comp 2 | RPM             | % Cond. Airflow | VSM Duty Cycle | RPM       | % Cond. Airflow | VSM Duty Cycle |
| OAT<20F       | >30Hz            | ON     | ON     | 533             | 45%             | 43%            | 530       | 45%             | 43%            |

**Note:** A 2 Hz hysteresis around the VSPD compressor will be implemented when transitioning from a high speed to a lower speed.

### Test Modes

VSPD compressor equipped units will require handling for two test mode sequences. See below for additional information on each mode.

### Failure and Protection Conditions

Certain failure and overriding conditions require special handling of the VSPD compressor. Refer to the following sections for details on each failure mode associated with the VSPD compressor and the unit response.

### Supply Air Temperature on SZVAV

If the supply air temperature sensor value is out of range/invalid on a unit configured for SZVAV, the unit will fall back to traditional constant volume control and the VSPD compressor will be controlled at 100% capacity for all requests for compressor operation. All start-up, shutdown, and oil recovery requirements will remain in effect for the VSPD compressor.

### Outside Air Temperature

If the OA temperature sensor value is out of range/invalid, an **outside air temperature invalid/out of range** diagnostic shall be generated. Condenser fan operation will default to 100% during all requests for compressor operation. This will remain consistent between single and multi-compressor configured units. The VSPD compressor will operate as a fixed speed compressor, being limited to 40Hz (2400 RPM) to protect against high ambient OAT operation. The **outside air temperature invalid/out of range** diagnostic shall automatically reset if a valid value is received by the controller.

### Evaporator Coil Frost Protection

When the OA temperature is less than 55°F (single compressor) 40° F (multi-compressor) the unit will enable the evaporator coil frost protection function. This function will cycle all compressors off every 10 minutes of continuous operation. For the variable speed compressor the shutdown and startup sequences will be incorporated into the timing extending the total variable speed compressor on time to 10 minutes plus shutdown sequence time before shutting off.

### Extended Time at Compressor Low Speed (Oil Recovery Mode)

- For 3 to 5 ton and 12.5 to 17.5 ton units: If the VSPD compressor operates for 19 continuous minutes with active compressor speed < 40Hz, the VSPD compressor shall ramp to 40Hz for minimum of 1 minute and then will be released back to normal operation.
- For 6 to 10 ton units: If the VSPD compressor operates for 19 continuous minutes with active compressor speed less than 45Hz, the VSPD compressor shall ramp to 45Hz for minimum of 1 minute and then will be released back to normal operation.

### High Ambient Operation Protection (3 to 5 ton and 12.5 to 17.5 ton eFlex™ Units)

If the OA temperature reaches temperature in excess of 100°F, ReliaTel™ controls will implement minimum and maximum compressor speed limits. The limits are shown in the following table.

**Table 31. Speed limits**

| Entering Outdoor Ambient (° F) | RPM Lower Limit (RPM) | RPM Lower Limit (Hz) | RPM Lower Limit (V) | RPM Upper Limit (RPM) | RPM Upper Limit (Hz) | RPM Upper Limit (V) |
|--------------------------------|-----------------------|----------------------|---------------------|-----------------------|----------------------|---------------------|
| 100                            | 1100                  | 18                   | 2.7                 | 4500                  | 75                   | 6.8                 |
| 107                            | 1300                  | 22                   | 2.9                 | 4500                  | 75                   | 6.8                 |
| 112                            | 1500                  | 25                   | 3.2                 | 4200                  | 70                   | 6.4                 |
| 118                            | 1800                  | 30                   | 3.5                 | 3600                  | 60                   | 5.7                 |
| 124                            | 2100                  | 35                   | 3.9                 | 3000                  | 50                   | 5                   |
| 127                            | 2400                  | 40                   | 4.3                 | 2400                  | 40                   | 4.3                 |

**Note:** As OAT decreases, leaving each condition occurs at an OAT of 2°F below the entering OAT temperature specified in the table.

### Precedent™ 6 to 10 ton eFlex™ Emerson Compressor Enabled Units

On eFlex units incorporating an Emerson™ compressor, a condensing temperature sensor and evaporator temperature sensor will be used to control the minimum compressor speed within the limits of the compressor operating map. This operating map control will not be active during AHRI test mode. These minimum compressor speed limitations are defined in the following table.

**Table 32. Compressor speed limit - Precedent™ eFlex™ 6 to 10 tons**

| Unit           | Evap Temp (°F)                    | Cond Temp (°F)                     | RPM Lower Limit (RPM) | RPM Lower Limit (Hz) | RPM Lower Limit (V) | RPM Upper Limit (RPM) | RPM Upper Limit (Hz) | RPM Upper Limit (V) |
|----------------|-----------------------------------|------------------------------------|-----------------------|----------------------|---------------------|-----------------------|----------------------|---------------------|
| 6 Tons         | Temp > 65°F                       | any                                | 2700                  | 45                   | 3.75                | 5000                  | 83                   | 6.92                |
|                | 20°F ≤ Temp < 65°F <sup>(a)</sup> | temp ≥ 125°F                       | 2700                  | 45                   | 3.75                | 5000                  | 83                   | 6.92                |
|                |                                   | 95°F ≤ temp < 125°F <sup>(b)</sup> | 1680                  | 28                   | 2.33                | 5000                  | 83                   | 6.92                |
|                |                                   | temp < 95°F <sup>(b)</sup>         | 1020                  | 17                   | 1.42                | 5000                  | 83                   | 6.92                |
| 7.5 to 10 Tons | Temp > 60°F                       | any                                | 2640                  | 44                   | 3.67                | 6000                  | 100                  | 8.33                |
|                | Temp < 60°F <sup>(a)</sup>        | temp ≥ 130°F                       | 2220                  | 37                   | 3.08                | 6000                  | 100                  | 8.33                |
|                |                                   | 95°F ≤ temp < 130°F <sup>(b)</sup> | 1800                  | 30                   | 2.5                 | 7200                  | 120                  | 10                  |
|                |                                   | temp < 95°F <sup>(b)</sup>         | 1320                  | 22                   | 1.83                | 7200                  | 120                  | 10                  |

**Note:** If any of the Evap Temp and Cond Temp sensor fails, operation outside the limitations of the operating map cannot be guaranteed. The compressor will not operate.

<sup>(a)</sup> As the Evap Temp decreases, leaving each condition occurs at a temperature of 8°F below the entering Evap Temp specified in the table.

<sup>(b)</sup> Cond Temp decreases, leaving each condition occurs at a temperature of 5°F below the entering Cond Temp temperature specified in the table.

## Compressor Protection

The connections for compressor proving and low pressure cutout for the VSPD compressor are on the VSM module. On multi-compressor units, each compressor will have its own compressor proving input, but will have one compressor disable input per refrigeration circuit.

If the case of compressor failure the following sequences will be used based on the compressor(s) failed:

- Variable speed compressor failed, fixed compressor circuit available:
- The system will revert to the staged compressor control.
- If compressor 2 disable input is active, only one fixed speed compressor is to be available during compressor stage-up efforts.
- Variable speed compressor available, fixed compressor circuit failed:
- The system will utilize the variable speed algorithm to stage the variable speed compressor as normal. The fixed compressor will not be able to respond to control requests.
- If compressor 2 disable input is active, up to 100% of the variable speed compressor capacity is to be available during compressor stage-up efforts.

## VSM Module Communication Failure

If the VSM module loses communication with the rest of the ReliaTel™ system, the unit will disable all VSPD compressor operation and will generate a **VSM module communication failure** diagnostic. On units with fixed speed compressors all compressors will be disabled due to OD fan being controlled through the VSM module.

## Compressor VFD Alarm Output Lockout

During a HPC event, there is a possibility that the compressor VFD drive will trip on an overcurrent condition

before the high pressure switch is active. To prevent a cycling condition with the compressor VFD drive, the following operation will be implemented.

If the HPC input on the VSM indicates a high pressure condition on the VSPD compressor circuit, the system will react identically the same as today's operation.

In the event that the system encounters the issue described in the above problem statement, the following logic will be used

- If the compressor VFD alarm is received in the first 3 minutes of ReliaTel™ compressor request, the compressor will shut down (as expected).
- The VSPD compressor will not be allowed to restart until the compressor VFD alarm has cleared.
- If the compressor VFD alarm is received in the first 3 minutes of ReliaTel™ compressor request four consecutive times, then the VSPD compressor will be locked out on a manual diagnostic.
- If the VSPD compressor runs longer than 3 minutes, the counter will be set to zero.

## VFD Troubleshooting and Support

**Table 33. VFD troubleshooting and support literature references**

| Product                        | Publication Number |
|--------------------------------|--------------------|
| Danfoss TR150                  | BAS-SVP16*-EN      |
| Danfoss TR200                  | BAS-SVP04*-EN      |
| Mitsubishi Compressor Inverter | RT-SVD008*-EN      |
| Toshiba Compressor Inverter    | RT-SVD007*-EN      |
| Ruking Compressor Inverter     | RT-SVD05*-EN       |

## Variable Speed Compressor Drive Troubleshooting

This section details the error and protection codes as shown through the LED display of the interface module. It includes detailed descriptions and troubleshooting methods for each error or protection code. During all error **E** codes, the compressor is shut down by the drive and 5 Vdc alarm output is present on the interface module.

### Error and Protection Code List

#### Incorrect Dip Switch Settings – Error Code: E0–1

**Criteria** - Dip switches on the interface module are not set according to the [Table 33, p. 80](#) for appropriate compressor model.

**Troubleshooting** - Verify the compressor model from compressor nameplate and check if the dip switches are set correctly on the interface module for that compressor model.

**Reset Criteria** - Set the dip switches on the interface module to correct settings and apply power to the drive.

#### Communication Failure – Error Code: E-02

**Criteria** - Loss of communication between interface module and the inverter module.

**Troubleshooting** - Verify the wiring connections between the interface module and the inverter module.

**Reset Criteria** - The protection will remain active for at least 2 minutes. After 2 minutes, protection mode will be deactivated when communication is re-established between interface board and the inverter module.

#### Hardware Over - Current Limit – Error Code: E-03

**Criteria** - Output current of the drive is higher than the specified limit for hardware over-current protection. During normal operation mode, the drive output current should not reach this value.

**Troubleshooting** - Verify there are no loose connections in input power wiring to the drive and output wiring from the electric drive to the compressor. Check compressor windings for any ground faults.

Check for abnormal conditions such as airflow blockage, improper condenser fan operation, compressor locked rotor situation, system charge, or other conditions that could cause the system to be overloaded.

**Reset Criteria** - The protection will remain active for at least 2 minutes. After 2 minutes, protection mode will be deactivated and drive will operate normally as long as the overload condition is no longer present.

#### Drive Operation Failure – Error Code: E-04

**Criteria** - Compressor doesn't start properly after five tries with 15 second intervals between each try. This could be caused by either loss of phase in drive output current to the compressor, compressor motor locked rotor situation, or damaged drive hardware.

**Troubleshooting** - Verify there are no loose connections in input power wiring to the drive and output wiring from the electric drive to the compressor. Check compressor windings for any ground faults.

Check if LED 602 is flashing On or completely Off. If Off, then inverter module is defective and needs to be replaced.

Cut off power to the drive and disconnect the output power (U, V, W) from the inverter module. By using the Diode settings on the multimeter, check the following 6 pairs of diodes: (DC+,U), (DC+,V), (DC+, W), (U,DC-), (V,DC-), (W, DC-). Perform a continuity check between the following pairs of terminals: (U, V), (V, W), (U, W). If any of the above pairs are shorted, then Integrated Power Module "IPM" is defective, and inverter module needs to be replaced.

**Reset Criteria** - The protection will remain active for at least 2 minutes. After 2 minutes, protection mode will be deactivated and drive will operate normally as long as the overload condition is no longer present.

#### Software Over-Current Limits – Protection Code: P-01 and Error Code: E-05

**Criteria** - Output current of the drive is higher than the specified limit for software over-current protection.

Over-current limits associated with P-01 code are lower than the limits associated with E-05. During P-01, the compressor speed is either reduced or held constant whereas during E-05, the compressor is requested to shut down to protect the drive.

During normal operation mode, the drive output current should not reach the limits associated with E-05.

**Troubleshooting** - Verify there are no loose connections in input power wiring to the drive and output wiring from the electric drive to the compressor. Check compressor windings for any ground faults.

Check for abnormal conditions such as airflow blockage, improper condenser fan operation, compressor locked rotor situation, system charge or other conditions that could cause the system to be overloaded.

**Reset Criteria** - The protection or error code will remain active for at least 2 minutes. After 2 minutes, protection or error mode will be deactivated and drive will operate normally as long as the overload conditions are no longer present.

### Output Current Sampling Error – Error Code: E-06

**Criteria** - At power up when the compressor is in Off state, if the inverter module doesn't properly detect the output current then the compressor would not be allowed to start.

**Troubleshooting** - Verify input power wiring to the drive and output power wiring from the drive to the compressor.

**Reset Criteria** - Error code can be de-activated by removing power to the drive and re-applying power.

### Heat Sink Over Heat - Protection Code P-02 and Error Code: E-07

**Criteria** - Temp sensor on the inverter module detects the temperature to be exceeding the limits defined in the inverter module software. Temp limits associated with P-02 are lower than the temp limits for E-07. During P-02, the compressor speed is either reduced or held constant whereas during E-07, the compressor is requested to shut down to protect the drive.

**Troubleshooting** - Verify refrigerant is flowing through the copper tubes used to cool the heat sink. Check for abnormal conditions such as airflow blockage, improper condenser fan operation, system over or under charge or other conditions that could result in higher amp draw on the drive and cause overheating.

**Reset Criteria** - The protection or error code will remain active for at least 2 minutes regardless of changes in temperature. After 2 minutes, if the temp is below the specified limits in the drive software, the protection or error mode will be deactivated.

### DC Bus Over Voltage and Under Voltage – Error Code: E-08

**Criteria** - DC bus voltage of the drive is above or below the specified limits for the drive.

230 Vac Drive limits: Above 370 Vdc or below 170 Vdc.

460 Vac Drive limits: Above 800 Vdc or below 300 Vdc.

**Troubleshooting** - Verify input voltage to the R, S, T terminals on the inverter module is within +/-10% of the rated unit voltage. Inspect DC bus board for any damaged capacitors.

**Reset Criteria** - The protection will remain active for at least 2 minutes regardless of DC bus voltage. After 2 minutes, Protection mode will be deactivated when DC bus voltage is below or above the specified limits for the drive.

### Incorrect Compressor Code – Error Code: E-09

**Criteria** - Interface module sends the compressor code that is not supported by the inverter module.

**Troubleshooting** - Verify dip switch settings on the interface module are set correctly for appropriate compressor model and re-apply power to the drive.

**Reset Criteria** - Error mode can be de-activated by removing power to the drive board and re-applying power.

### Heat Sink Temperature Sensor Error – Error Code: E-12

**Criteria** - Heat sink temp sensor on the inverter module is reporting temperature readings outside the spec limit.

**Troubleshooting** - Verify heat sink temp sensor connector is plugged into the drive board and the sensor itself is not shorted/open.

**Reset Criteria** - The protection will remain active for at least 2 minutes. After 2 minutes, protection mode will be deactivated when sensor reading is within the allowed spec.

### Drive Board Internal Communication Error – Error Code: E-13

**Criteria** - Internal communication loss between the inverter module chips for at least 15 sec.

**Troubleshooting** - Verify connections between the interface module and the inverter module.

**Reset Criteria** - The protection will remain active for at least 2 minutes. After 2 minutes, protection mode will be deactivated when communication is re-established between the inverter chips.

### 3-Phase AC Input Power Phase-Loss – Error Code: E-15

**Criteria** - Loss of any of three phases of AC input power for longer than 30 msec when the drive has been powered for at least 8 seconds.

**Troubleshooting** - Verify all three phases of AC input power to the R, S, T terminals on the inverter module.

**Reset Criteria** - The protection will remain active for at least 2 minutes. After 2 minutes, protection mode will be deactivated and drive will operate normally.

### Magnetic Field Weakening Control – Protection Code: P-05

**Criteria** - When the magnetic field angle between the compressor rotor and stator is below the specified value in the software, protection mode will be activated and compressor speed will be reduced gradually.

**Troubleshooting** - Check for abnormal conditions such as airflow blockage, improper condenser fan operation, system over or under charge or other conditions that could result in overload conditions on the compressor and cause this situation.

**Reset Criteria** - The protection mode will remain active until the angle value is smaller than specified value in the software.

# Verifying Proper Airflow

## Precedent™

### 3 to 5 Ton 17 Plus/WHC/DHC Units with Constant CFM Direct Drive Indoor Fan

Proper airflow is critical to unit operation. All 17 Plus Precedent (037, 047, and 067) and WHC/DHC use an indoor fan that provides a constant cfm.

There are two different types of 17 Plus and WHC/DHC Precedent units:

- Single Zone VAV units
- Multi-Speed units

Both types of units use the same type of indoor motor and the same airflow adjustment procedure.

To adjust airflow on a 17 Plus/WHC/DHC unit, the Service Test mode must be used for accurate results. Additionally, airflow adjustments should be made in either cool stage 2 or any stage of heat because the fan is driven to its maximum setting during these stages. Only the maximum fan setting requires adjustment, all other fan speeds follow the maximum adjustment and do not require any adjustment.

Using the Service Test, enter the unit into either cool stage 2 or any stage of heat by using either the step test mode or resistance test mode. Once the unit is in either cool stage 2 or any stage of heat, system airflow (cfm) is determined by:

1. In the indoor fan compartment, locate the R136 potentiometer on the RTOM circuit board (also designated DA COOL - FAN SPD). Locate the TP1 test pin loop next to the R136 potentiometer.
2. Measure the DC voltage across the test pin TP1 and unit chassis ground. Compare DC voltage to the cfm chart shown in [Table 34, p. 83](#) which shows DC voltage corresponds to cfm per ton of unit cooling.

**Note:** If 1200 cfm is required from a 3 ton unit (037), the R136 potentiometer should be adjusted so that the DC voltage measured at TP1 to ground reads 1.65 volts DC.

3. To decrease the TP1 voltage, turn the R136 potentiometer counterclockwise.
4. To increase the TP1 voltage, turn the R136 potentiometer clockwise.

**Note:** With the indoor fan access panel removed, the fan will operate at a lower rpm because static pressure is reduced with the door open. Once the panel is returned the rpm of the indoor fan will increase.

Table 34. CFM vs. VDC

| PWM % value | Potentiometer Voltage (VDC) | CFM/Ton |
|-------------|-----------------------------|---------|
| 70          | <.1                         | 320     |
| 75          | 0.7                         | 347     |
| 80          | 1.25                        | 373     |
| 85          | 1.65                        | 400     |
| 90          | 1.95                        | 427     |
| 95          | 2.17                        | 453     |
| 100         | >2.4                        | 480     |

### Units with 5-Tap Direct Drive Indoor Fan

Much of the systems performance and reliability is closely associated with, and dependent upon having the proper airflow supplied both to the space that is being conditioned and across the evaporator coil.

The indoor fan motor is factory wired to operate on speed tap 1 in the cooling and heating mode for electric/electric units. For gas/electric units, the motor is factory wired to operate on speed tap 1 during cooling. For 3 and 4 ton gas/electric units operating in heat mode, the minimum setting is Tap 4.

For these units, a separate tap terminal is provided to change speeds automatically between heating and cooling. The motor can be rewired for different speed settings should the application require it. Refer to the wiring diagram that shipped in the unit and the unit fan performance tables.

The indoor fan motors are specifically designed to operate within the bhp parameters listed in the fan performance tables.

When verifying direct drive fan performance, the tables must be used somewhat differently than those of belt driven fans. Fan performance diagnostics can be easily recognized when these tables are used correctly. Before starting the service test, set the minimum position setpoint for the economizer to 0 percent using the setpoint potentiometer located on the economizer control module (RTEM), if applicable.

#### ReliaTel™ Control

Using the service test guide, momentarily jump across the Test 1 and Test 2 terminals on LTB1 one time to start the minimum ventilation test.

With the fan operating properly, determine the total system external static pressure (inches wc) by the following method (ReliaTel™/Electromechanical):

1. Measure the supply and return duct static pressure and sum the resulting absolute values.

## Verifying Proper Airflow

- Use the accessory pressure drop table, calculate the total static pressure drop for all accessories installed on the unit such as air filters, economizer, etc.

**Note:** Accessory static pressure drop is based on desired cfm and may not be actual static pressure drop.

- Add the total accessory static pressure drop (step 2) to the duct external static pressure (step 1). The sum of these two values represents the total system external static pressure.

Using the Fan Performance Tables, look up the selected speed tap setting and match the measured ESP to determine the approximate cfm. If the required cfm is too low, (external static pressure is high) do one or both of the following and repeat procedure:

- Relieve supply and/or return duct static.
- Change indoor fan speed tap to a higher value. If the required cfm is too high, (external static pressure is low), do one or both of the following and repeat procedure:
  - Increase supply and/or return duct static.
  - Change indoor fan speed tap to a lower value.

**Note:** Minimum setting for units with gas or electric heat is 320 cfm per ton. For 3 and 4 ton gas heat units operating in heating mode the heat speed set cannot be lower than speed set 4.

- To stop the service test, turn the main power disconnect switch to the off position or proceed to the next component start-up procedure.

### ReliaTel™ Units with Direct Drive Indoor Plenum Fan

**Note:** 10 tons standard efficiency, 6 (074) to 10 tons high efficiency and optional on 7.5 (092) to 8.5 tons standard efficiency.

Much of the systems performance and reliability is closely associated with, and dependent upon having the proper airflow supplied both to the space that is being conditioned and across the evaporator coil. The indoor fan speed is changed by adjusting the voltage from the RTOM indoor fan speed output to the direct drive plenum fan.

If installed, before starting the service test disable the economizer by disconnecting the 4-pin power connector located at the base of the economizer control module (RTEM).

Momentarily jump across the Test 1 and Test 2 terminals on LTB1. Repeat process until service test mode is at cool 2 (two steps of cooling applications only) or cool 3 (three steps of cooling applications).

The indoor motor shall operate at 100%. To verify, turn DA COOL\_FAN SPD potentiometer full clockwise and voltage should read approximately 7.5 Vdc across harness test terminals. The unit schematic illustrates location for measuring the indoor motor speed voltage.

**Table 35. Direct drive plenum fan settings (rpm vs. voltage)**

| Potentiometer Voltage | Motor RPM |
|-----------------------|-----------|
| 1.0                   | N/A       |
| 1.25                  | N/A       |
| 1.5                   | N/A       |
| 1.75                  | N/A       |
| 2.0                   | N/A       |
| 2.25                  | 325       |
| 2.5                   | 402       |
| 2.75                  | 465       |
| 3.0                   | 544       |
| 3.25                  | 630       |
| 3.5                   | 716       |
| 3.75                  | 775       |
| 4.0                   | 845       |
| 4.25                  | 912       |
| 4.5                   | 976       |
| 4.75                  | 1044      |
| 5.0                   | 1115      |
| 5.25                  | 1203      |
| 5.5                   | 1253      |
| 5.75                  | 1312      |
| 6.0                   | 1368      |
| 6.25                  | 1425      |
| 6.5                   | 1475      |
| 6.75                  | 1533      |
| 7.0                   | 1581      |
| 7.25                  | 1615      |
| 7.5                   | 1615      |



## Sequence of Operation

Once the supply fan has started, determine the total system airflow (cfm).

1. Measure the DC voltage across harness test terminals. Using the fan rpm table shown above, determine rpm correlated to measured voltage.
2. If the required cfm is too low, (external static pressure is high causing motor HP output to be below the table value).
  - a. Relieve supply and/or return duct static.
  - b. Change indoor fan speed and repeat steps 1 and 2.
3. To increase/decrease fan rpm turn DA COOL\_FAN SPD on the RTOM clockwise/counter clockwise.
4. If the required cfm is too high, (external static pressure is low causing motor HP output to be above table value), change indoor fan speed and repeat steps 1 and 2.
5. Stop the service test and turn the main power disconnect switch to the off position.
6. Reconnect the economizer 4-pin power connector if disconnected for this procedure.

## ReliaTel™ Control

**Note:** Momentarily jump across the Test 1 and Test 2 terminals on LTB1. Repeat process until service test mode is at cool 2 (two steps of cooling applications only), cool 3 (three steps of cooling applications), or heat mode (if applicable).

## Electromechanical Control

Perform the proper test mode connections.

## Total System Airflow (Electromechanical)

Once the supply fan has started, determine the total system airflow (cfm) by:

1. Note the DC voltage shown on the ECM board display. Using the fan rpm table shown on the power diagram and determine rpm correlated to measured voltage.
2. Measure the amperage at the supply fan contactor and compare it with the full load amp (FLA) rating for the evaporator motor stamped on the unit nameplate.
3. If the required cfm is too low, (external static pressure is high causing motor hp output to be below table value):
  - a. Relieve supply and/or return duct static.
  - b. Change indoor fan speed and repeat step 1 and 2. Refer to the following section for fan speed adjustment.
4. If the required cfm is too high, (external static pressure is low causing motor hp output to be above table value), change indoor fan speed and repeat step 1 and 2.
5. To stop the service test, turn the main power disconnect switch to the **off** position or proceed to the

next component start-up procedure.

## Fan Speed Adjustment

### ECM Board

1. Push and hold the SET button for 3 seconds. Board will display motor 1 parameter name = Hi 1.
2. Slow push SET again to display the parameters current value = 7.50 volts.
3. Push on + or – button to adjust parameter to desired value = XXX volts.
4. Push and hold SET button for 3 seconds to save the value. After save is complete, Hi 1 will show again.
5. After the voltage Hi 1 is successfully changed, the display sequence will be: MTR 1—> XXX —> MTR2 —> 0.00—>FST1—>ON/OFF—>FST2—>ON/OFF—>EhEn—>ON/OFF And the motor will ramp up or down to adjust to the input signal.
6. Using the fan rpm table to determine RPM correlated to displayed voltage.

## Voyager Light Commercial (12.5 to 25 Tons)

Much of the systems performance and reliability is closely associated with, and dependent upon having the proper airflow supplied both to the space that is being conditioned and across the evaporator coil. The indoor fan speed is changed by opening or closing the adjustable motor sheave. Before starting the service test, set the minimum position setpoint for the economizer to 0% using the setpoint potentiometer(s) located on the economizer control module (RTEM) and ventilation module (RTVM), if applicable.

Using the service test guide, momentarily jump across the Test 1 and Test 2 terminals on LTB1 one time to start the minimum ventilation test. Once the supply fan has started, check for proper rotation. The direction of rotation is indicated by an arrow on the fan housing. With the fan operating properly, determine the total system airflow (cfm):

1. Measure the actual rpm.
2. Measure the amperage at the supply fan contactor and compare it with the full load amp (FLA) rating stamped on the motor nameplate.
  - a. Calculate the theoretical bhp:
 
$$\frac{\text{Actual Motor Amps}}{\text{Motor Nameplate Amps}} \times \text{Motor HP}$$
  - b. Using the fan performance tables, plot the actual rpm (Step 1) and the bhp (Step 2a) to obtain the operating cfm.
3. If the required cfm is too low, (external static pressure is high causing motor horsepower output to be below table value):

## Verifying Proper Airflow

---

1. Relieve supply and/or return duct static.
2. Change indoor fan speed and repeat [Step 1](#) and [Step 2](#).
4. To increase fan rpm, loosen the pulley adjustment set screw and turn sheave clockwise.
5. To decrease fan rpm, loosen the pulley adjustment set screw and turn sheave counterclockwise.
6. If the required cfm is too high, (external static pressure is low causing motor horsepower output to be above table value), change indoor fan speed and repeat [Step 1](#) and [Step 2](#).
7. To stop the service test, turn the main power disconnect switch to the **off** position or proceed to the next component start-up procedure. Remove electromechanical test mode connections (if applicable).

# ReliaTel™ LED Functions

## Modules and Codes

| ReliaTel™ Refrigeration Module (RTRM)                  |  |
|--|--|
| Green System LED                                       | <ul style="list-style-type: none"> <li>On: Normal operation (slight flickering is normal)</li> <li>Off: No power, board failure</li> <li>One blink: Emergency stop open when attempting test mode</li> <li>2 flashes every two seconds indicates a diagnostic is present (V 4.0 or greater) [see "RTRM System LED Diagnostic Indicator," p. 34 for a list of diagnostics]</li> <li>Continuous ¼ second blink: Test mode</li> </ul> |
| Green Transmit LED                                     | <ul style="list-style-type: none"> <li>Very fast flash: Normal operation, information being sent to other modules</li> <li>Off: System failure, no power</li> </ul>  |
| Yellow Receive LED                                     | <ul style="list-style-type: none"> <li>Very fast flash 0.5 second, off 1.5 second: Normal communication</li> <li>¼ second wink every 2 seconds: Not communicating with any other module</li> <li>Off: Board failure, no power</li> </ul>   |
| ReliaTel™ Options Module (RTOM)                        |  |
| Green system LED                                       | <ul style="list-style-type: none"> <li>On: Normal communication with RTRM</li> <li>¼ second on, 2 seconds off: No communication</li> <li>Off: No power or board failure</li> </ul>   |
| ReliaTel™ Ventilation Module (RTVM)                    |  |
| Green system LED                                       | <ul style="list-style-type: none"> <li>On: Normal communication with RTRM</li> <li>¼ second on, 2 seconds off: No communication</li> <li>Off: No power or board failure</li> </ul>   |
| ReliaTel™ Air Handling Module (RTAM)                   |  |
| Green system LED                                       | <ul style="list-style-type: none"> <li>On: Normal communication with RTRM</li> <li>¼ second on, 2 seconds off: No communication</li> <li>Off: No power or board failure</li> </ul>   |
| ReliaTel™ Dehumidification Module (RTDM)               |  |
| Green system LED                                       | NA - No onboard LED  |
| ReliaTel™ Variable Speed Module (VSM) Green System LED |  |
| Green system LED                                       | <ul style="list-style-type: none"> <li>On: Normal communication with RTRM</li> <li>¼ second on, 2 seconds off: No communication</li> <li>Off: No power or board failure</li> </ul>   |

| <b>Economizer Actuator Module (ECA or RTEM)</b>   |  |
|---|--|
| <b>Green system LED</b>                           | <ul style="list-style-type: none"> <li>• On: OK to economize</li> <li>• Slow flash: Not OK to economize                             <ul style="list-style-type: none"> <li>– ½ second on, ¼ second off</li> </ul> </li> <li>• Fast flash: Not communicating with RTRM                             <ul style="list-style-type: none"> <li>– ¼ second on, 2 seconds off</li> </ul> </li> <li>• Off: No power or system failure</li> <li>• Error codes:                             <ul style="list-style-type: none"> <li>– 1 flash – Actuator fault                                     <ul style="list-style-type: none"> <li>• 2 seconds on, ¼ seconds off</li> </ul> </li> <li>– 2 flash – CO<sub>2</sub> sensor</li> <li>– 3 flash – RA humidity sensor</li> <li>– 4 flash – RA temp sensor</li> <li>– 6 flash – OA humidity sensor</li> <li>– 7 flash – No communication with RTRM or OAT sensor has failed</li> <li>– 8 flash – MA temp sensor</li> <li>– 9 -11 flash – Internal fault</li> </ul> </li> </ul> |
| <b>Ignition Control (IGN)<sup>(a)</sup></b>       |  |
| <b>Green system LED</b>                           | <ul style="list-style-type: none"> <li>• On: Normal no call for heat</li> <li>• Slow flash: Active call for heat</li> <li>• Fast flash: Not communicating with RTRM</li> <li>• Error codes:                             <ul style="list-style-type: none"> <li>– 2 flash – system lockout – failure to sense flame</li> <li>– 3 flash – pressure switch failure to close when CBM stops or open when CBM starts (not applicable to 12.5 to 50 tons)</li> <li>– 4 flash – TCO circuit open</li> <li>– 5 flash – Flame being sensed yet gas valve not energized</li> <li>– 6 flash – Flame rollout (FR) circuit open</li> </ul> <p><i>Note: 6 flash not applicable to 12.5 to 50 tons.</i></p> </li></ul>  |
| <b>TCI COMM3/4 Interface (Tracer®, VariTrac®)</b> |  |
| <b>Yellow RX (Receive) LED</b>                    | <ul style="list-style-type: none"> <li>• Flashing intermittently: ICS line activity</li> <li>• Off: Communication down or no power</li> </ul>  |
| <b>Green TX (Transmit) LED</b>                    | <ul style="list-style-type: none"> <li>• Flashing intermittently: Unit is communicating OK with ICS system</li> <li>• Off yet RX light flashes – address wrong, COMM3/4 board in wrong position</li> </ul>   |
| <b>LCI (LonTalk®)</b>                             |  |
| <b>LED 1 Green MODBUS LED</b>                     | Flashing intermittently: Unit is communicating to RTRM   |
| <b>LED 1 Green MODBUS LED</b>                     | <ul style="list-style-type: none"> <li>• Flashing intermittently: Unit is communicating to RTRM</li> <li>• Off: LCI-R not operating</li> <li>• Flashing slow (¼ second on and 2 seconds off): RTRM is not responding.</li> </ul>   |
| <b>LED 2 Red Service LED</b>                      | <ul style="list-style-type: none"> <li>• Steady on: Bad circuit board</li> <li>• Off: Normal</li> <li>• Flashing 1 second on, 1 second off, LCI is in unconfigured state.</li> </ul>   |
| <b>LED3 Yellow Comm RX</b>                        | Flashing intermittently: normal operation.   |
| <b>LED4 Green COMM 5 status LED</b>               | Steady on: Normal operation.   |

<sup>(a)</sup> See ignition control section for specific flash code schedule.

**BCI (BACnet®)****Table 36. Interpreting the LEDs**

| LED type     | LED activity        | Indicates   |
|--------------|---------------------|---|
| Service LED  | Solid green         | The controller is in boot mode. The controller will be placed into boot mode if the service pin is held in when power is applied. In boot mode, the controller is non-operational and is waiting for a new main application to be downloaded. While in boot mode, the system will not run any applications. |
|              | Not illuminated     | Application code is running; operating normally   |
| Status LED   | Solid green         | Normal operation  |
|              | Blinking green      | The controller is updating the flash  |
|              | Solid red           | The controller has malfunctioned  |
|              | Blinking red        | Alarms or point faults are present  |
|              | Not illuminated     | The controller is off   |
| Link Tx/Rx   | TX blinks green     | Data is being transferred, received, or transmitted   |
|              | RX blinks yellow    | Blinks at the data transfer rate when the unit receives data from other devices on the link ON solid yellow; indicates there is reverse polarity  |
|              | Not illuminated     | No activity is occurring  |
| Modbus Tx/Rx | Blinking            | Data is being transferred, received, or transmitted   |
|              | Not illuminated     | No activity is occurring  |
| Link LEDs    | MSTP is illuminated | The link switch has been set to wired communication   |
|              | WCI is illuminated  | The link switch has been set to wireless communication  |

# ReliaTel™ Test Mode

**Note:** See technical literature to verify test sequence.

## Protocol, Modes, and Tests

### Protocol of Communications

It is possible, but not recommended, to connect multiple control devices to a ReliaTel™ system. The terminal strip is

arranged for simultaneous connection of ICS communication (Tracker®, Tracer® Summit, VariTrac®), mechanical zone sensor module (ZSM), programmable zone sensor, and a conventional thermostat. Only one device can control the unit at a time. If communication fails, the RTRM seeks the next lower priority level device. If no device is connected, the unit will not only run during **test** mode.

|                  |  |
|------------------|--|
| Highest priority | ICS (Tracker®, Tracer® Summit, VariTrac®, Summit) - Using BAYSENS013, 014, 017 as needed |
| Next priority    | Programmable Zone Sensor (BAYSENS019, AYSTAT666, BAYSENS020)                             |
| Next priority    | Mechanical ZSM (BAYSENS006-11B, AYSTAT661-664)   |
| Least priority   | Conventional Thermostat (R, G, Y, W, C)  |

Connecting multiple devices will increase the chance for error in application and troubleshooting.

**Note:** 27.5 to 50 tons VAV conventional thermostat inputs do not work and are ignored by the RTRM.

On power up, the RTRM looks for a zone temperature input (J6-1, J6-2). If it doesn't see one, it ignores zone sensor inputs and looks for thermostat (RGYW) inputs. If the unit does see a valid zone temperature input on start-up, then the thermostat (RGYW) inputs are ignored. A programmable zone sensor will take priority over either input when connected. An ICS system takes the highest priority.

### Service Test Mode

Allows the qualified service technician or installer to activate all functions of the unit, regardless of thermostat, sensor, or in some cases ICS input. Test mode is activated using either a fixed resistance or a jumper as explained below.

In Service **test** mode, the unit can be operated in any of several pre-defined operating modes that exercise all unit functions.

Operating modes include:

- Supply fan on
- Economizer open
- Economizer close
- Cool 1
- Cool 2
- Cool 3
- Reheat valve (for staged dehumidification)
- Modulating reheat and cooling valves
- Reheat circuit pumpout solenoid
- Heat 1
- Heat 2

- Outdoor coil defrost
- Emergency heat (heat pump only)

If a unit does not have a component, such as an economizer, that test stage is skipped. There are three ways to use the **test** mode. In each case, the unit can be running in any mode or not running at all. Service **test** mode can be initiated any time the unit is powered and an open condition has been detected on the Test Terminals at some time since power-up.

### Auto-Cycle Test

1. Place a jumper from test 1 to test 2. The unit will run in each mode for 30 seconds, scrolling through all modes, then exiting the **test** mode automatically.
2. To go through **test** mode again, remove and then restore the jumper. If the jumper is removed at any time during the **test** mode, the unit will stay in the selected mode for 1 hour (except for the defrost mode on heat pumps), then revert to normal operation.

Unused states, such as Heat 2 when no Heat 2 is present, shall be skipped.

### Resistance Test

Specific operating states can be selected by applying an appropriate resistance from test 1 to test 2. Operating modes can be changed in any order by applying the correct resistance values. Operation in any one mode is limited to 60 minutes as with the jumper method.

**Table 37. Resistance test**

| Step             | Mode            | Resistance |
|------------------|-----------------|------------|
| 1                | Indoor fan on   | 2.2k ohms  |
| 2 <sup>(a)</sup> | Economizer open | 3.3k ohms  |
| 3                | Cool 1          | 4.7k ohms  |
| 4 <sup>(a)</sup> | Cool 2          | 6.8k ohms  |
| 5 <sup>(a)</sup> | Cool 3          | 8.2k ohms  |

**Table 37. Resistance test (continued)**

| Step             | Mode                 | Resistance |
|------------------|----------------------|------------|
| 5                | Heat 1               | 10k ohms   |
| 6 <sup>(a)</sup> | Heat 2               | 15k ohms   |
| 7 <sup>(a)</sup> | Heat 3               | 22k ohms   |
| 9 <sup>(a)</sup> | Heat 4               | 27k ohms   |
| 8 <sup>(b)</sup> | Defrost cycle/reheat | 33k ohms   |
| 9 <sup>(a)</sup> | Emergency heat       | 47k ohms   |

<sup>(a)</sup> Optional components

<sup>(b)</sup> Defrost cycle in test mode runs for at least 1 minute, up to 10 minutes, depending on outdoor ambient and outdoor coil temperature. Reheat step is valid only with dehumidification option and will be step 5 of the test.

## Step Test

- Place a jumper from test 1 to test 2 for 2 continuous seconds nominal, allowing the unit to energize the mode for at least 2 seconds.
- Place the jumper again so the unit can scroll through modes quicker than in method 1.

Unused states, such as Heat 2 when no Heat 2 is present, shall be skipped.

**Note:** 27.5 to 50 tons units see test mode chart and following figure.

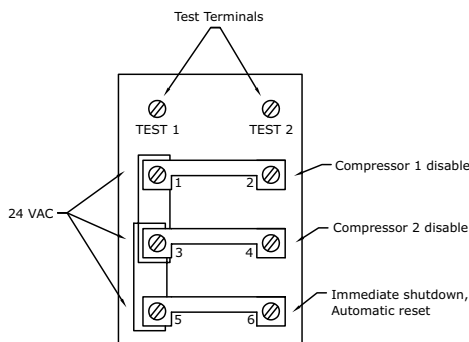
**Figure 56. LTB layout with jumpers**

## Test Modes

### Service Tips

- To ensure appropriate unit restart after operating in service **test** mode: Service **test** mode termination causes a system reset resulting in execution of the startup sequence identical to initial power-on startup.
- To prevent undesired activation of service **test** mode at start-up: Service **test** mode can only be activated after an open condition has been detected on the service test terminals.
- When initiating the test mode immediately after power-up: The RTRM 20 seconds self-test must be completed before the test mode will work.
- The **test** mode bypasses timing functions including minimum run times.

- Test** mode does not bypass safety controls such as the high temperature limit switch, high pressure control or smoke detector circuits.
- To help with troubleshooting, unplug J4 from the RTRM. This removes all optional components such as the COMM3/4, ECA or RTEM and RTOM. This may prevent key features from functioning. Avoid this procedure on 27.5 to 50 tons units as the configuration will be lost.
- Some test functions do not work with LCI installed. Remove LCI from the circuit before entering the **test** mode.
- For MZVAV or true VAV units, there will be an approximate 6 minute delay before the heat will start in Test mode. This allows the VAVs in the ductwork to fully open before increasing the fan speed to 100%.
- Test jumper should be removed from test 1 and terminals and/or service test switch must be in the off position when power is applied to the unit. If this is not done, the unit will not go into **test** mode.

### Emergency Stop Input, LTB 5 and 6 (3J1-12 on RTRM)

If this input is open, the indoor fan, heat and cooling will not run in the **test** mode. The diagnostic for this condition is HEAT FAIL + COOL FAIL. When this input is closed, the unit will restart.

When initiating the **test** mode, if emergency stop is open, the LED on the RTRM will flash one time.

### Fan Proving input, 5J7-6 on RTOM

The indoor fan will run in the **test** mode for 40 seconds and then stop if this input fails to open (3 to 25 tons) or close (27.5 to 50 tons) within 40 seconds. The diagnostic for this failure is SERVICE (pulsing 1.5 – 2.5 Vdc from RTRM J6-6 to J6-10).

### Compressor Disable Inputs, 3J1-8, 3J3-2 (Two Compressor Units) on RTRM

If this input is open, ie. 24 Vac not present, that compressor circuit will not run during **test** mode. No diagnostic will be seen.

### Compressor Proving Circuits, 3J1-9, 3J3-3 (Two Compressor Units) on RTRM

If this input is open when the contactor is energized by the RTRM, that circuit will not run during **test** mode. The diagnostic for this failure is COOL FAIL.

Gas heat failures, such as TCO, PS, FR will not be bypassed during **test** mode (see unit wiring diagram). Diagnostics can be picked up at the ignition control module. An additional diagnostic for this failure is HEAT FAIL.

### **Ventilation Override Mode (VOM), J6 on the RTOM**

While in the **test** mode, if a VOM is activated, test mode will temporarily be halted. When the VOM is terminated, the **test** mode will continue from where it was halted.

### **CO<sub>2</sub> Option Through DCV Input on ECA or RTEM**

**Test** mode will operate normally with a CO<sub>2</sub> signal. When the economizer step is initiated, the CO<sub>2</sub> signal is overridden. When the **test** mode goes to the next step, the CO<sub>2</sub> signal is re-established. The economizer will drive to

the closed position and then proceed to drive open from the CO<sub>2</sub> signal.

### **ECA or RTEM Minimum Position Adjustment**

During the economizer step (step 2 of test mode), the "Min pos" on the ECA or RTEM module is disabled. It can only be adjusted during step 1 of the test when the fan is on.

### **Frostat™ Input**

J7-1, J7-2 on RTOM - if this input closes indicating a frosted suction line, the compressors will not run during the **test** mode.



# ReliaTel™ Test Mode Tables

**Table 38. Precedent™ 3 to 10 tons standard efficiency heat pump CV (with unloading compressor)**

| Mode        | C1 Unloaded           | C2 Loaded             | CFA                 | CFB                   | Heat 1 | Heat 2 | SOV1 | Econ | S Fan | S Fan Speed Command (PWM)  | S Fan Speed Command (ECM) | Resistance |
|-------------|-----------------------|-----------------------|---------------------|-----------------------|--------|--------|------|------|-------|----------------------------|---------------------------|------------|
| 1. Fan On   | Off                   | Off                   | Off                 | Off                   | Off    | Off    | Off  | Min. | On    | Min Speed                  | 100%                      | 2.2K       |
| 2. Econ     | Off                   | Off                   | Off                 | Off                   | Off    | Off    | On   | 100% | On    | Min Speed                  | 100%                      | 3.3K       |
| 3. Cool 1   | On                    | Off                   | Norm <sup>(a)</sup> | Norm <sup>(a)</sup>   | Off    | Off    | On   | Min. | On    | 57% or 70% <sup>(b)</sup>  | 100%                      | 4.7K       |
| 4. Cool 2   | On                    | On                    | Norm <sup>(a)</sup> | Norm <sup>(a)</sup>   | Off    | Off    | On   | Min. | On    | 82% or 100% <sup>(b)</sup> | 100%                      | 6.8K       |
| 5. Heat 1   | On                    | Off                   | Off                 | On                    | Off    | Off    | Off  | Min. | On    | 100%                       | 100%                      | 10K        |
| 6. Heat 2   | On                    | On                    | Off                 | On                    | Off    | Off    | Off  | Min. | On    | 100%                       | 100%                      | 15K        |
| 7. Heat 3   | On/Off <sup>(c)</sup> | On/Off <sup>(c)</sup> | Off                 | On/Off <sup>(c)</sup> | On     | Off    | Off  | Min. | On    | 100%                       | 100%                      | 22K        |
| 8. Heat 4   | On/Off <sup>(c)</sup> | On/Off <sup>(c)</sup> | Off                 | On/Off <sup>(c)</sup> | On     | On     | Off  | Min. | On    | 100%                       | 100%                      | 27K        |
| 9. Defrost  | On                    | On                    | Off                 | Off                   | On     | Off    | On   | Min. | On    | 100%                       | 100%                      | 33K        |
| 10. Em Heat | Off                   | Off                   | Off                 | Off                   | On     | On     | Off  | Min. | On    | 100%                       | 100%                      | 47K        |

<sup>(a)</sup> Normal condenser fan staging shall remain in effect during service test mode.

<sup>(b)</sup> Dependent on the short run timer.

<sup>(c)</sup> Dependent on auxiliary heat being electric heat (on) or gas heat (off).

**Table 39. Precedent™ 3 to 10 tons standard efficiency heat pump 2-speed (with unloading compressor)**

| Mode        | C1 Unloaded           | C2 Loaded             | CFB                 | Heat 1 | Heat 2 | SOV1 | Econ | S Fan | S Fan Speed Command (PWM) | S Fan Speed Command (ECM) | Resistance |
|-------------|-----------------------|-----------------------|---------------------|--------|--------|------|------|-------|---------------------------|---------------------------|------------|
| 1. Fan On   | Off                   | Off                   | Off                 | Off    | Off    | Off  | Min. | On    | 50%                       | 68%                       | 2.2K       |
| 2. Econ     | Off                   | Off                   | Off                 | Off    | Off    | On   | 100% | On    | 50%                       | 68%                       | 3.3K       |
| 3. Cool 1   | On                    | Off                   | Norm <sup>(a)</sup> | Off    | Off    | On   | Min. | On    | 50%                       | 68%                       | 4.7K       |
| 4. Cool 2   | On                    | On                    | Norm <sup>(a)</sup> | Off    | Off    | On   | Min. | On    | 50%                       | 68%                       | 6.8K       |
| 5. Heat 1   | On                    | On                    | Off                 | Off    | Off    | Off  | Min. | On    | 50% <sup>(b)</sup>        | 68%                       | 10K        |
| 6. Heat 2   | On                    | On                    | Off                 | Off    | Off    | Off  | Min. | On    | 100% <sup>(b)</sup>       | 100%                      | 15K        |
| 7. Heat 3   | On/Off <sup>(c)</sup> | On/Off <sup>(c)</sup> | Off                 | On     | Off    | Off  | Min. | On    | 100%                      | 100%                      | 22K        |
| 8. Heat 4   | On/Off <sup>(c)</sup> | On/Off <sup>(c)</sup> | Off                 | On     | On     | Off  | Min. | On    | 100%                      | 100%                      | 27K        |
| 9. Defrost  | On                    | On                    | Off                 | On     | Off    | On   | Min. | On    | 100%                      | 100%                      | 33K        |
| 10. Em Heat | Off                   | Off                   | Off                 | On     | On     | Off  | Min. | On    | 100%                      | 100%                      | 47K        |

<sup>(a)</sup> Normal condenser fan staging shall remain in effect during service test mode.

<sup>(b)</sup> Depends on if heat mode has a higher maximum fan speed then cool mode.

<sup>(c)</sup> Dependent on auxiliary heat being electric heat (on) or gas heat (off).

**Table 40. Precedent™ 3 to 10 tons standard efficiency heat pump SZVAV (with unloading compressor)**

| Mode      | C1 Unloaded           | C2 Loaded             | CFA                 | CFB                   | Heat 1 | Heat 2 | SOV1 | Econ | S Fan | S Fan Speed Command (PWM) | S Fan Speed Command (ECM) | Resistance |
|-----------|-----------------------|-----------------------|---------------------|-----------------------|--------|--------|------|------|-------|---------------------------|---------------------------|------------|
| 1. Fan On | Off                   | Off                   | Off                 | Off                   | Off    | Off    | Off  | Min. | On    | 50%                       | 68%                       | 2.2K       |
| 2. Econ   | Off                   | Off                   | Off                 | Off                   | Off    | Off    | Off  | 100% | On    | 50%                       | 68%                       | 3.3K       |
| 3. Cool 1 | On                    | Off                   | Norm <sup>(a)</sup> | Norm <sup>(a)</sup>   | Off    | Off    | On   | Min. | On    | 70%                       | 79%                       | 4.7K       |
| 4. Cool 2 | On                    | On                    | Norm <sup>(a)</sup> | Norm <sup>(a)</sup>   | Off    | Off    | On   | Min. | On    | 100%                      | 100%                      | 6.8K       |
| 5. Heat 1 | On                    | Off                   | Off                 | On                    | Off    | Off    | Off  | Min. | On    | 70%                       | 79%                       | 10K        |
| 6. Heat 2 | On                    | On                    | Off                 | On                    | Off    | Off    | Off  | Min. | On    | 100%                      | 100%                      | 15K        |
| 7. Heat 3 | On/Off <sup>(b)</sup> | On/Off <sup>(b)</sup> | Off                 | On/Off <sup>(b)</sup> | On     | Off    | Off  | Min. | On    | 100%                      | 100%                      | 22K        |
| 8. Heat 4 | On/Off <sup>(b)</sup> | On/Off <sup>(b)</sup> | Off                 | On/Off <sup>(b)</sup> | On     | On     | Off  | Min. | On    | 100%                      | 100%                      | 27K        |

**Table 40. Precedent™ 3 to 10 tons standard efficiency heat pump SZVAV (with unloading compressor) (continued)**

| Mode        | C1 Unloaded | C2 Loaded | CFA | CFB | Heat 1 | Heat 2 | SOV1 | Econ | S Fan | S Fan Speed Command (PWM) | S Fan Speed Command (ECM) | Resistance |
|-------------|-------------|-----------|-----|-----|--------|--------|------|------|-------|---------------------------|---------------------------|------------|
| 9. Defrost  | On          | On        | Off | Off | On     | Off    | On   | Min. | On    | 100%                      | 100%                      | 33K        |
| 10. Em Heat | Off         | Off       | Off | Off | On     | On     | Off  | Min. | On    | 100%                      | 100%                      | 47K        |

(a) Normal condenser fan staging shall remain in effect during service test mode.  
 (b) Dependent on auxiliary heat being electric heat (on) or gas heat (off).

**Table 41. Precedent™ 3 to 10 tons standard efficiency heat pump MZVAV (with unloading compressor)**

| Mode                     | C1                    | C2                    | CFA                 | CFB                   | Heat 1 | Heat 2 | SOV1 | Econ   | S Fan | S Fan Speed Command (PWM and ECM) | Resistance |
|--------------------------|-----------------------|-----------------------|---------------------|-----------------------|--------|--------|------|--------|-------|-----------------------------------|------------|
| 1. IGV/VFD Open          | Off                   | Off                   | Off                 | Off                   | Off    | Off    | Off  | Closed | Off   | Min Speed                         | NA         |
| 2. IGV/VFD Closed        | Off                   | Off                   | Off                 | Off                   | Off    | Off    | Off  | Closed | Off   | Min Speed                         | NA         |
| 3. Fan On / Min Vent     | Off                   | Off                   | Off                 | Off                   | Off    | Off    | Off  | Min.   | On    | Min Speed                         | 2.2K       |
| 4. Econ                  | Off                   | Off                   | Off                 | Off                   | Off    | Off    | On   | 100%   | On    | In Control <sup>(a)</sup>         | 3.3K       |
| 5. Cool 1                | On                    | Off                   | Norm <sup>(b)</sup> | Norm <sup>(b)</sup>   | Off    | Off    | On   | Min.   | On    | In Control <sup>(a)</sup>         | 4.7K       |
| 6. Cool 2                | On                    | On                    | Norm <sup>(b)</sup> | Norm <sup>(b)</sup>   | Off    | Off    | On   | Min.   | On    | In Control <sup>(a)</sup>         | 6.8K       |
| 7. Heat 1 <sup>(c)</sup> | On                    | Off                   | Off                 | On                    | Off    | Off    | Off  | Min.   | On    | 100%                              | 10K        |
| 8. Heat 2 <sup>(c)</sup> | On                    | On                    | Off                 | On                    | Off    | Off    | Off  | Min.   | On    | 100%                              | 15K        |
| 9. Heat 3 <sup>(c)</sup> | On/Off <sup>(d)</sup> | On/Off <sup>(d)</sup> | Off                 | On/Off <sup>(d)</sup> | On     | Off    | Off  | Min.   | On    | 100%                              | 22K        |
| 10. Heat 4               | On/Off <sup>(d)</sup> | On/Off <sup>(d)</sup> | Off                 | On/Off <sup>(d)</sup> | On     | On     | Off  | Min.   | On    | 100%                              | 27K        |
| 11. Defrost              | On                    | On                    | Off                 | Off                   | On     | Off    | On   | Min.   | On    | 100%                              | 33K        |
| 12. Em Heat              | Off                   | Off                   | Off                 | Off                   | On     | On     | Off  | Min.   | On    | 100%                              | 47K        |

(a) Supply fan speed controlled to duct static pressure.  
 (b) Normal condenser fan staging shall remain in effect during service test mode.  
 (c) 6 minute time delay before heat will initiate.  
 (d) Dependent on auxiliary heat being electric heat (on) or gas heat (off).

**Table 42. Precedent™ 6 to 10 tons high efficiency heat pump CV (with unloading compressor)**

| Mode        | C1 Unloaded           | C2 Loaded             | EMAIR Fan Spd (Fixed Spd) | CFB                 | Heat 1 | Heat 2 | SOV 1 | Econ | S Fan | S Fan Speed Command (ECM) | Resistance |
|-------------|-----------------------|-----------------------|---------------------------|---------------------|--------|--------|-------|------|-------|---------------------------|------------|
| 1. Fan On   | Off                   | Off                   | Off                       | Off                 | Off    | Off    | Off   | Min. | On    | 100%                      | 2.2K       |
| 2. Econ     | Off                   | Off                   | Off                       | Off                 | Off    | Off    | On    | 100% | On    | 100%                      | 3.3K       |
| 3. Cool 1   | On                    | Off                   | Off                       | Norm <sup>(a)</sup> | Off    | Off    | On    | Min. | On    | 100%                      | 4.7K       |
| 4. Cool 2   | On                    | On                    | Off                       | Norm <sup>(a)</sup> | Off    | Off    | On    | Min. | On    | 100%                      | 6.8K       |
| 5. Cool 3   | On                    | On                    | On                        | Norm <sup>(a)</sup> | Off    | Off    | On    | Min. | On    | 100%                      | 8.2K       |
| 6. Heat 1   | On                    | On                    | Off                       | Off                 | Off    | Off    | Off   | Min. | On    | 100%                      | 10K        |
| 7. Heat 2   | On                    | On                    | On                        | Off                 | Off    | Off    | Off   | Min. | On    | 100%                      | 15K        |
| 8. Heat 3   | On/Off <sup>(b)</sup> | On/Off <sup>(b)</sup> | On/Off <sup>(b)</sup>     | Off                 | On     | Off    | Off   | Min. | On    | 100%                      | 22K        |
| 9. Heat 4   | On/Off <sup>(b)</sup> | On/Off <sup>(b)</sup> | On/Off <sup>(b)</sup>     | Off                 | On     | On     | Off   | Min. | On    | 100%                      | 27K        |
| 10. Defrost | On                    | On                    | On                        | Off                 | On     | Off    | On    | Min. | On    | 100%                      | 33K        |
| 11. Em Heat | Off                   | Off                   | Off                       | Off                 | On     | On     | Off   | Min. | On    | 100%                      | 47K        |

(a) Normal condenser fan staging shall remain in effect during service test mode.  
 (b) Dependent on auxiliary heat being electric heat (on) or gas heat (off).

**Table 43. Precedent™ 6 to 10 tons high efficiency heat pump multi-speed fan (with unloading compressor)**

| Mode        | C1 Unloaded           | C2 Loaded             | EMAIR Fan Spd (Fixed Spd) | CFB                 | Heat 1 | Heat 2 | SOV 1 | Econ | S Fan | S Fan Speed Command (ECM) | Resistance |
|-------------|-----------------------|-----------------------|---------------------------|---------------------|--------|--------|-------|------|-------|---------------------------|------------|
| 1. Fan On   | Off                   | Off                   | Off                       | Off                 | Off    | Off    | Off   | Min. | On    | 68%                       | 2.2K       |
| 2. Econ     | Off                   | Off                   | Off                       | Off                 | Off    | Off    | On    | 100% | On    | 68%                       | 3.3K       |
| 3. Cool 1   | On                    | Off                   | Off                       | Norm <sup>(a)</sup> | Off    | Off    | On    | Min. | On    | 68%                       | 4.7K       |
| 4. Cool 2   | On                    | On                    | Off                       | Norm <sup>(a)</sup> | Off    | Off    | On    | Min. | On    | 50%                       | 6.8K       |
| 5. Cool 3   | On                    | On                    | On                        | Norm <sup>(a)</sup> | Off    | Off    | On    | Min  | On    | 100%                      | 8.2K       |
| 6. Heat 1   | On                    | On                    | Off                       | Off                 | Off    | Off    | Off   | Min. | On    | 68% <sup>(b)</sup>        | 10K        |
| 7. Heat 2   | On                    | On                    | On                        | Off                 | Off    | Off    | Off   | Min. | On    | 100% <sup>(b)</sup>       | 15K        |
| 8. Heat 3   | On/Off <sup>(c)</sup> | On/Off <sup>(c)</sup> | On/Off <sup>(c)</sup>     | Off                 | On     | Off    | Off   | Min. | On    | 100%                      | 22K        |
| 9. Heat 4   | On/Off <sup>(c)</sup> | On/Off <sup>(c)</sup> | On/Off <sup>(c)</sup>     | Off                 | On     | On     | Off   | Min. | On    | 100%                      | 27K        |
| 10. Defrost | On                    | On                    | On                        | Off                 | On     | Off    | On    | Min. | On    | 100%                      | 33K        |
| 11. Em Heat | Off                   | Off                   | Off                       | Off                 | On     | On     | Off   | Min. | On    | 100%                      | 47K        |

<sup>(a)</sup> Normal condenser fan staging shall remain in effect during service test mode.

<sup>(b)</sup> Depends on if heat mode has a higher maximum fan speed than cool mode.

<sup>(c)</sup> Dependent on auxiliary heat being electric heat (on) or gas heat (off).

**Table 44. Precedent™ 6 to 10 tons high efficiency heat pump SZVAV (with unloading compressor)**

| Mode        | C1 Unloaded           | C2 Loaded             | EMAIR Fan Spd (Fixed Spd) | CFB                 | Heat 1 | Heat 2 | SOV 1 | Econ | S Fan | S Fan Speed Command (ECM) | Resistance |
|-------------|-----------------------|-----------------------|---------------------------|---------------------|--------|--------|-------|------|-------|---------------------------|------------|
| 1. Fan On   | Off                   | Off                   | Off                       | Off                 | Off    | Off    | Off   | Min. | On    | 68%                       | 2.2K       |
| 2. Econ     | Off                   | Off                   | Off                       | Off                 | Off    | Off    | On    | 100% | On    | 68%                       | 3.3K       |
| 3. Cool 1   | On                    | Off                   | Off                       | Norm <sup>(a)</sup> | Off    | Off    | On    | Min. | On    | 68%                       | 4.7K       |
| 4. Cool 2   | On                    | On                    | Off                       | Norm <sup>(a)</sup> | Off    | Off    | On    | Min. | On    | 68%                       | 6.8K       |
| 5. Cool 3   | On                    | On                    | On                        | Norm <sup>(a)</sup> | Off    | Off    | On    | Min  | On    | 100%                      | 8.2K       |
| 6. Heat 1   | On                    | On                    | Off                       | Off                 | Off    | Off    | Off   | Min. | On    | 68% <sup>(b)</sup>        | 10K        |
| 7. Heat 2   | On                    | On                    | On                        | Off                 | Off    | Off    | Off   | Min. | On    | 100% <sup>(b)</sup>       | 15K        |
| 8. Heat 3   | On/Off <sup>(c)</sup> | On/Off <sup>(c)</sup> | On/Off <sup>(c)</sup>     | Off                 | On     | Off    | Off   | Min. | On    | 100%                      | 22K        |
| 9. Heat 4   | On/Off <sup>(c)</sup> | On/Off <sup>(c)</sup> | On/Off <sup>(c)</sup>     | Off                 | On     | On     | Off   | Min. | On    | 100%                      | 27K        |
| 10. Defrost | On                    | On                    | On                        | Off                 | On     | Off    | On    | Min. | On    | 100%                      | 33K        |
| 11. Em Heat | Off                   | Off                   | Off                       | Off                 | On     | On     | Off   | Min. | On    | 100%                      | 47K        |

<sup>(a)</sup> Normal condenser fan staging shall remain in effect during service test mode.

<sup>(b)</sup> Depends on if heat mode has a higher maximum fan speed than cool mode.

<sup>(c)</sup> Dependent on auxiliary heat being electric heat (on) or gas heat (off).

**Table 45. Precedent™ 6 to 10 tons high efficiency heat pump MZVAV (with unloading compressor)**

| Mode                      | C1 Unloaded           | C2 Loaded             | EMAIR Fan Spd (Fixed Spd) | CFB                 | Heat 1 | Heat 2 | SOV 1 | Econ   | S Fan | S Fan Speed Command (ECM) | Resistance |
|---------------------------|-----------------------|-----------------------|---------------------------|---------------------|--------|--------|-------|--------|-------|---------------------------|------------|
| 1. IGV/VFD Open           | Off                   | Off                   | Off                       | Off                 | Off    | Off    | Off   | Closed | Off   | Min Speed                 | NA         |
| 2. IGV/VFD Close          | Off                   | Off                   | Off                       | Off                 | Off    | Off    | Off   | Closed | Off   | Min Speed                 | NA         |
| 3. Fan On                 | Off                   | Off                   | Off                       | Off                 | Off    | Off    | Off   | Min.   | On    | Min Speed                 | 2.2K       |
| 4. Econ                   | Off                   | Off                   | Off                       | Off                 | Off    | Off    | On    | 100%   | On    | Min Speed                 | 3.3K       |
| 5. Cool 1                 | On                    | Off                   | Off                       | Norm <sup>(a)</sup> | Off    | Off    | On    | Min.   | On    | Min Speed                 | 4.7K       |
| 6. Cool 2                 | On                    | On                    | Off                       | Norm <sup>(a)</sup> | Off    | Off    | On    | Min.   | On    | In Control <sup>(b)</sup> | 6.8K       |
| 7. Cool 3                 | On                    | On                    | On                        | Norm <sup>(a)</sup> | Off    | Off    | On    | Min    | On    | In Control <sup>(b)</sup> | 8.2K       |
| 8. Heat 1 <sup>(c)</sup>  | On                    | On                    | Off                       | Off                 | Off    | Off    | Off   | Min.   | On    | 100% <sup>(d)</sup>       | 10K        |
| 9. Heat 2 <sup>(c)</sup>  | On                    | On                    | On                        | Off                 | Off    | Off    | Off   | Min.   | On    | 100% <sup>(d)</sup>       | 15K        |
| 10. Heat 3 <sup>(c)</sup> | On/Off <sup>(e)</sup> | On/Off <sup>(e)</sup> | On/Off <sup>(e)</sup>     | Off                 | On     | Off    | Off   | Min.   | On    | 100% <sup>(d)</sup>       | 22K        |

## ReliaTel™ Test Mode Tables

**Table 45. Precedent™ 6 to 10 tons high efficiency heat pump MZVAV (with unloading compressor) (continued)**

| Mode                      | C1 Unloaded           | C2 Loaded             | EMAIR Fan Spd (Fixed Spd) | CFB | Heat 1 | Heat 2 | SOV 1 | Econ | S Fan | S Fan Speed Command (ECM) | Resistance |
|---------------------------|-----------------------|-----------------------|---------------------------|-----|--------|--------|-------|------|-------|---------------------------|------------|
| 11. Heat 4 <sup>(c)</sup> | On/Off <sup>(e)</sup> | On/Off <sup>(e)</sup> | On/Off <sup>(e)</sup>     | Off | On     | On     | Off   | Min. | On    | 100% <sup>(d)</sup>       | 27K        |
| 12. Defrost               | On                    | On                    | On                        | Off | On     | Off    | On    | Min. | On    | 100%                      | 33K        |
| 13. Em Heat               | Off                   | Off                   | Off                       | Off | On     | On     | Off   | Min. | On    | 100%                      | 47K        |

(a) Normal condenser fan staging shall remain in effect during service test mode.

(b) Supply fan Speed controlled to duct static pressure.

(c) 6 minute time delay before heat will initiate.

(d) Depends on if heat mode has a higher maximum fan speed than cool mode.

(e) Dependent on auxiliary heat being electric heat (on) or gas heat (off).

**Table 46. Voyager™ and precedent™ gas/electric units 3 to 25 tons**

| Step             | Mode   | IDM   | Econ | CPR1 | CPR2              | HT1 | HT2 | Mod Gas | ODM1 | ODM2           |
|------------------|--------|---|------|------|-------------------|-----|-----|---------|------|----------------|
| 1                | Fan On | On/Low <sup>(a)</sup>   | Min  | Off  | Off               | Off | Off | Off     | Off  | Off            |
| 2 <sup>(a)</sup> | Econ.  | On/Low <sup>(a)</sup>   | Open | Off  | Off               | Off | Off | Off     | Off  | Off            |
| 3                | Cool 1 | On/Low <sup>(a)</sup> /Medium <sup>(a)</sup>                      | Min  | On   | On <sup>(b)</sup> | Off | Off | Off     | On   | <sup>(c)</sup> |
| 4                | Cool 2 | On/Low <sup>(a)</sup> /Medium <sup>(a)</sup> /High <sup>(a)</sup> | Min  | On   | On <sup>(d)</sup> | Off | Off | Off     | On   | <sup>(c)</sup> |
| 5                | Cool 3 | On/High <sup>(a)</sup>  | Min  | On   | On                | Off | Off | Off     | On   | <sup>(c)</sup> |
| 6 <sup>(a)</sup> | Reheat | On/High <sup>(a)</sup>  | Min  | On   | On                | Off | Off | Off     | On   | <sup>(c)</sup> |
| 7 <sup>(a)</sup> | Heat 1 | On/Low <sup>(a)</sup> /High <sup>(a)</sup>                        | Min  | Off  | Off               | On  | Off | 50%     | Off  | Off            |
| 8 <sup>(a)</sup> | Heat 2 | On/High <sup>(a)</sup>  | Min  | Off  | Off               | On  | On  | 100%    | Off  | Off            |

**Note:** Steps for optional accessories and modes not present in unit will be skipped.

(a) With optional accessory.

(b) CPR2 ON during Cool 1 if configured for 3-step cooling; CPR1 OFF.

(c) Off if OAT falls below 60°F, On if OAT rises above 65°F. During reheat, if the unit is configured with 1 compressor, ODM2 is Off if the OAT falls below 70°F, On if the OAT rises above 75°F.

(d) CPR2 OFF during Cool 2 on a 3-step cooling unit.

**Table 47. Voyager™ and precedent™ electric/electric units 3 to 25 tons**

| Step             | Mode   | IDM   | Econ | CPR1 | CPR2              | HT1 | HT2 | ODM1 | ODM2           |
|------------------|--------|---|------|------|-------------------|-----|-----|------|----------------|
| 1                | Fan On | On/Low <sup>(a)</sup>   | Min  | Off  | Off               | Off | Off | Off  | Off            |
| 2 <sup>(a)</sup> | Econ.  | On/Low <sup>(a)</sup>   | Open | Off  | Off               | Off | Off | Off  | Off            |
| 3                | Cool 1 | On/Medium <sup>(a)</sup>  | Min  | On   | On <sup>(b)</sup> | Off | Off | On   | <sup>(c)</sup> |
| 4                | Cool 2 | On/Low <sup>(a)</sup> /Medium <sup>(a)</sup> /High <sup>(a)</sup> | Min  | On   | On <sup>(d)</sup> | Off | Off | On   | <sup>(c)</sup> |
| 5                | Cool 3 | On/High <sup>(a)</sup>  | Min  | On   | On                | Off | Off | On   | <sup>(c)</sup> |
| 6 <sup>(a)</sup> | Reheat | On/High <sup>(a)</sup>  | Min  | On   | On                | Off | Off | On   | <sup>(c)</sup> |
| 7 <sup>(a)</sup> | Heat 1 | On/High <sup>(a)</sup>  | Min  | Off  | Off               | On  | Off | Off  | Off            |
| 8 <sup>(a)</sup> | Heat 2 | On/High <sup>(a)</sup>  | Min  | Off  | Off               | On  | On  | Off  | Off            |

**Note:** Steps for optional accessories and modes not present in unit will be skipped.

(a) With optional accessory.

(b) CPR2 ON during Cool 1 if configured for 3-step cooling; CPR1 OFF.

(c) Off if OAT falls below 60°F, On if OAT rises above 65°F. During reheat, if the unit is configured with 1 compressor, ODM2 is Off if the OAT falls below 70°F, On if the OAT rises above 75°F.

(d) CPR2 OFF during Cool 2 on a 3-step cooling unit.

**Table 48. Voyager™ and precedent™ heat pump units 3 to 20 tons**

| Step              | Mode    | IDM   | Econ | CPR1 | CPR2              | HT1               | HT2               | SOV1 | ODM1 | ODM2           |
|-------------------|---------|---|------|------|-------------------|-------------------|-------------------|------|------|----------------|
| 1                 | Fan On  | On/Low <sup>(a)</sup>   | Min  | Off  | Off               | Off               | Off               | Off  | Off  | Off            |
| 2 <sup>(a)</sup>  | Econ.   | On/Low <sup>(a)</sup>   | Open | Off  | Off               | Off               | Off               | Off  | Off  | Off            |
| 3                 | Cool 1  | On/Low <sup>(a)</sup> /Medium <sup>(a)</sup>                      | Min  | On   | On <sup>(b)</sup> | Off               | Off               | On   | On   | <sup>(c)</sup> |
| 4                 | Cool 2  | On/Low <sup>(a)</sup> /Medium <sup>(a)</sup> /High <sup>(a)</sup> | Min  | On   | On <sup>(d)</sup> | Off               | Off               | On   | On   | <sup>(c)</sup> |
| 5                 | Cool 3  | On/High <sup>(a)</sup>  | Min  | On   | On                | Off               | Off               | On   | On   | <sup>(c)</sup> |
| 6 <sup>(a)</sup>  | Reheat  | On/High <sup>(a)</sup>  | Min  | On   | On <sup>(e)</sup> | Off               | Off               | Off  | On   | On             |
| 7 <sup>(a)</sup>  | Heat 1  | On/High <sup>(a)</sup>  | Min  | On   | On                | On <sup>(f)</sup> | Off               | Off  | On   | On             |
| 8 <sup>(a)</sup>  | Heat 2  | On/High <sup>(a)</sup>  | Min  | On   | On                | On                | On <sup>(g)</sup> | Off  | On   | On             |
| 9 <sup>(a)</sup>  | Heat 4  | On/High <sup>(a)</sup>  | Min  | On   | On                | On                | On                | Off  | On   | On             |
| 10 <sup>(h)</sup> | Defrost | On/High <sup>(a)</sup>  | Min  | On   | On                | On                | On                | On   | Off  | Off            |
| 11                | Em Heat | On/High <sup>(a)</sup>  | Min  | Off  | Off               | On                | On                | Off  | Off  | Off            |

**Note:** Steps for optional accessories and modes not present in unit will be skipped.

- <sup>(a)</sup> With optional accessory.
- <sup>(b)</sup> CPR2 ON during Cool 1 if configured for 3-step cooling; CPR1 OFF.
- <sup>(c)</sup> Off if OAT falls below 60°F, On if OAT rises above 65°F. During reheat, if the unit is configured with 1 compressor, ODM2 is Off if the OAT falls below 70°F, On if the OAT rises above 75°F.
- <sup>(d)</sup> CPR2 OFF during Cool 2 on a 3-step cooling unit.
- <sup>(e)</sup> CPR2 OFF during Heat 1 if configured for 2-step mechanical heating.
- <sup>(f)</sup> HT1 OFF during Heat 2 if the unit is configured for 2-step mechanical heating.
- <sup>(g)</sup> HT2 OFF during Heat 3 if the unit is configured for 2-step mechanical heating.
- <sup>(h)</sup> Defrost cycle in test mode runs for at least 1 minute, up to 10 minutes, depending on outdoor ambient and outdoor coil temperature.

**Table 49. Precedent™ electric/electric — 17 SEER**

| Test Step        | Mode                 | Fan | Econ                         | Comp 1            | Comp 2            | Heat 1 | Heat 2 | Resistance | Output              | Multi-Speed Fan Output                        |
|------------------|----------------------|-----|------------------------------|-------------------|-------------------|--------|--------|------------|---------------------|---|
| 1                | Fan                  | On  | Minimum Position Setpoint 0% | Off               | Off               | Off    | Off    | 2.2KΩ      | 50%                 | low   |
|                  | Minimum Ventilation  | On  | Selectable                   | Off               | Off               | Off    | Off    |            |                     |   |
| 2                | Economizer Test Open | On  | Open                         | Off               | Off               | Off    | Off    | 3.3KΩ      | 50% <sup>(a)</sup>  | low   |
| 3                | Cool Stage 1         | On  | Minimum Position             | On <sup>(b)</sup> | Off               | Off    | Off    | 4.7KΩ      | 82%                 | low   |
| 4 <sup>(c)</sup> | Cool Stage 2         | On  | Minimum Position             | On <sup>(b)</sup> | On <sup>(b)</sup> | Off    | Off    | 6.8KΩ      | 100%                | High (2-step cooling)<br>Low (3-step cooling) |
| 5 <sup>(c)</sup> | Cool Stage 3         | On  | Minimum Position             | On <sup>(b)</sup> | On <sup>(b)</sup> | Off    | Off    | 8.2KΩ      | 100%                | High  |
| 6 <sup>(c)</sup> | Reheat               | On  | Minimum Position             | On                | On                | Off    | Off    | 33KΩ       | 100% <sup>(d)</sup> | High  |
| 7 <sup>(c)</sup> | Heat Stage 1         | On  | Minimum Position             | Off               | Off               | On     | Off    | 10KΩ       | 100%                | High  |
| 8 <sup>(c)</sup> | Heat Stage 2         | On  | Minimum Position             | Off               | Off               | On     | On     | 15KΩ       | 100%                | High  |

**Notes:**

1. The exhaust fan will turn on anytime the economizer damper position is equal to or greater than the exhaust fan setpoint.
2. The modulating output is in reference to the user selected maximum unit fan speed.

- <sup>(a)</sup> Regardless of the economizer mode configuration, the unit will run the supply fan at the minimum speed during the economizer step of the service test.
- <sup>(b)</sup> The condenser fans will operate any time a compressor is On providing the outdoor air temperatures are within the operating values.
- <sup>(c)</sup> Steps for optional accessories and non-applicable modes in unit will be skipped.
- <sup>(d)</sup> Units with enhanced dehumidification only will not perform this step during service test.

# ReliaTel™ Test Mode Tables

**Table 50. Precedent™ gas/electric — 17 SEER**

| Test Step        | Mode                 | Fan | Econ                         | Comp 1            | Comp 2            | Heat 1 | Heat 2 | Resistance | PWM Output |
|------------------|----------------------|-----|------------------------------|-------------------|-------------------|--------|--------|------------|------------|
| 1                | Fan                  | On  | Minimum Position Setpoint 0% | Off               | Off               | Off    | Off    | 2.2KΩ      | 50%        |
|                  | Minimum Ventilation  | On  | Selectable                   | Off               | Off               | Off    | Off    |            |            |
| 2                | Economizer Test Open | On  | Open                         | Off               | Off               | Off    | Off    | 3.3KΩ      | 50%(a)     |
| 3                | Cool Stage 1         | On  | Minimum Position             | On <sup>(b)</sup> | Off               | Off    | Off    | 4.7KΩ      | 82%        |
| 4 <sup>(c)</sup> | Cool Stage 2         | On  | Minimum Position             | On <sup>(b)</sup> | On <sup>(b)</sup> | Off    | Off    | 6.8KΩ      | 100%       |
| 5 <sup>(c)</sup> | Cool Stage 3         | On  | Minimum Position             | On <sup>(b)</sup> | On <sup>(b)</sup> | Off    | Off    | 8.2KΩ      | 100%       |
| 6 <sup>(c)</sup> | Reheat               | On  | Minimum Position             | On                | On                | Off    | Off    | 33KΩ       | 100%(d)    |
| 7 <sup>(c)</sup> | Heat Stage 1         | On  | Minimum Position             | Off               | Off               | On     | Off    | 10KΩ       | 100%       |
| 8 <sup>(c)</sup> | Heat Stage 2         | On  | Minimum Position             | Off               | Off               | On     | On     | 15KΩ       | 100%       |

**Notes:**

- The exhaust fan will turn on anytime the economizer damper position is equal to or greater than the exhaust fan setpoint.
  - The modulating output is in reference to the user selected maximum unit fan speed.
- (a) Regardless of the economizer mode configuration, the unit will run the supply fan at the minimum speed during the economizer step of the service test.
- (b) The condenser fans will operate any time a compressor is On providing the outdoor air temperatures are within the operating values.
- (c) Steps for optional accessories and non-applicable modes in unit will be skipped.
- (d) Units with enhanced dehumidification only will not perform this step during service test.

**Table 51. Voyager™ 12.5 to 25 tons eFlex™**

| Test Step | Mode   | Supply Fan% Output | VSPD Compressor Capacity Output | Fixed Compressor 1 | Fixed Compressor 2 | Outdoor Fan PWM Output |
|-----------|--------|--------------------|---------------------------------|--------------------|--------------------|------------------------|
| 1         | Fan On | 0%/25%             | 0%                              | OFF                | OFF                | 0%                     |
| 2         | Econ   | 0%/25%             | 0%                              | OFF                | OFF                | 0%                     |
| 3         | Cool 1 | 67%/75%            | 50%                             | OFF                | OFF                | (a)                    |
| 4         | Cool 2 | 100%               | 100%                            | ON                 | OFF                | (a)                    |
| 5         | Cool 3 | 100%               | 100%                            | ON                 | ON                 | (a)                    |
| 6         | Heat 1 | 100%               | 0%                              | OFF                | OFF                | 0%                     |
| 7         | Heat 2 | 100%               | 0%                              | OFF                | OFF                | 0%                     |

**Notes:**

- The supply fan % output is in reference to the user selected maximum unit fan speed. Unit will operate at 100% fan speed during heating.
  - First % shown is the control signal percentage. Second % is the actual fan speed percentage.
  - The supply fan and compressor outputs shall follow all startup and shutdown requirements prior to moving through test mode steps that change the states of the compressor output from ON to OFF or OFF to ON.
  - All compressor % outputs are in reference to the 100% capacity point per unit tonnage.
- (a) Condenser fan operation will be controlled based on the active OAT and compressor speed as during normal operation.

**Table 52. Odyssey™ 10 and 20 tons condenser - CV (with unloading compressor)**

| Mode      | C1 Unloaded | C2 Unloaded | CFA                 | CFB                 | Heat 1 | Heat 2 | SOV2 Comp 1&2 Loaded | Econ | S Fan | Resistance Test |
|-----------|-------------|-------------|---------------------|---------------------|--------|--------|----------------------|------|-------|-----------------|
| 1. Fan On | Off         | Off         | Off                 | Off                 | Off    | Off    | Off                  | NA   | On    | 2.2KΩ           |
| 2. Econ   | Off         | Off         | Off                 | Off                 | Off    | Off    | Off                  | NA   | On    | 3.3 KΩ          |
| 3. Cool 1 | On          | On          | Norm <sup>(a)</sup> | Norm <sup>(a)</sup> | Off    | Off    | Off                  | NA   | On    | 4.7 KΩ          |
| 4. Cool 2 | On          | On          | Norm <sup>(a)</sup> | Norm <sup>(a)</sup> | Off    | Off    | On                   | NA   | On    | 6.8 KΩ          |
| 7. Heat 1 | Off         | Off         | Off                 | Off                 | On     | Off    | Off                  | NA   | On    | 10 KΩ           |
| 8. Heat 2 | Off         | Off         | Off                 | Off                 | On     | On     | Off                  | NA   | On    | 15 KΩ           |

- (a) Normal condenser fan staging shall remain in effect during service test mode.

**Table 53. Odyssey™ 10 and 20 tons condenser - 2-speed (with unloading compressor)**

| Mode      | C1 Unloaded | C2 Unloaded | CFA                 | CFB                 | Heat 1 | Heat 2 | SOV2 Comp 1&2 Loaded | Econ | S Fan | S Fan      | Resistance Test |
|-----------|-------------|-------------|---------------------|---------------------|--------|--------|----------------------|------|-------|------------|-----------------|
| 1. Fan On | Off         | Off         | Off                 | Off                 | Off    | Off    | Off                  | NA   | On    | Low Speed  | 2.2KΩ           |
| 2. Econ   | Off         | Off         | Off                 | Off                 | Off    | Off    | Off                  | NA   | On    | Low Speed  | 3.3 KΩ          |
| 3. Cool 1 | On          | On          | Norm <sup>(a)</sup> | Norm <sup>(a)</sup> | Off    | Off    | Off                  | NA   | On    | Low Speed  | 4.7 KΩ          |
| 4. Cool 2 | On          | On          | Norm <sup>(a)</sup> | Norm <sup>(a)</sup> | Off    | Off    | On                   | NA   | On    | High Speed | 6.8 KΩ          |
| 7. Heat 1 | Off         | Off         | Off                 | Off                 | On     | Off    | Off                  | NA   | On    | High Speed | 10 KΩ           |
| 8. Heat 2 | Off         | Off         | Off                 | Off                 | On     | On     | Off                  | NA   | On    | High Speed | 15 KΩ           |

<sup>(a)</sup> Normal condenser fan staging shall remain in effect during service test mode.

**Table 54. Odyssey™ 10 and 20 tons condenser - SZVAV (with unloading compressor)**

| Mode      | C1 Unloaded | C2 Unloaded | CFA                 | CFB                 | Heat 1 | Heat 2 | SOV2 Comp 1&2 Loaded | Econ | S Fan | S Fan      | Resistance Test |
|-----------|-------------|-------------|---------------------|---------------------|--------|--------|----------------------|------|-------|------------|-----------------|
| 1. Fan On | Off         | Off         | Off                 | Off                 | Off    | Off    | Off                  | NA   | On    | Min Speed  | 2.2KΩ           |
| 2. Econ   | Off         | Off         | Off                 | Off                 | Off    | Off    | Off                  | NA   | On    | Min Speed  | 3.3 KΩ          |
| 3. Cool 1 | On          | On          | Norm <sup>(a)</sup> | Norm <sup>(a)</sup> | Off    | Off    | Off                  | NA   | On    | Mid Speed  | 4.7 KΩ          |
| 4. Cool 2 | On          | On          | Norm <sup>(a)</sup> | Norm <sup>(a)</sup> | Off    | Off    | On                   | NA   | On    | High Speed | 6.8 KΩ          |
| 7. Heat 1 | Off         | Off         | Off                 | Off                 | On     | Off    | Off                  | NA   | On    | High Speed | 10 KΩ           |
| 8. Heat 2 | Off         | Off         | Off                 | Off                 | On     | On     | Off                  | NA   | On    | High Speed | 15 KΩ           |

<sup>(a)</sup> Normal condenser fan staging shall remain in effect during service test mode.

**Table 55. Odyssey™ independent circuit heat pump units 15 to 20 tons**

| Step             | Mode     | IDM                    | Econ | CPR1 | CPR2 | HT1 | HT2 | SOV 1 | SOV 2 | ODM1 | ODM2 |
|------------------|----------|------------------------|------|------|------|-----|-----|-------|-------|------|------|
| 1                | Fan On   | On/Low <sup>(a)</sup>  | Min  | Off  | Off  | Off | Off | Off   | Off   | Off  | Off  |
| 3                | Cool 1   | On/Low <sup>(a)</sup>  | Min  | On   | Off  | Off | Off | On    | On    | On   | Off  |
| 4                | Cool 2   | On/High <sup>(a)</sup> | Min  | On   | On   | Off | Off | On    | On    | On   | On   |
| 5                | Heat 1   | On/High <sup>(a)</sup> | Min  | On   | Off  | Off | Off | Off   | Off   | On   | Off  |
| 6                | Heat 2   | On/High <sup>(a)</sup> | Min  | On   | On   | Off | Off | Off   | Off   | On   | On   |
| 7 <sup>(a)</sup> | Heat 3   | On/High <sup>(a)</sup> | Min  | On   | On   | On  | Off | Off   | Off   | On   | On   |
| 8 <sup>(a)</sup> | Heat 4   | On/High <sup>(a)</sup> | Min  | On   | On   | On  | On  | Off   | Off   | On   | On   |
| 9 <sup>(b)</sup> | Defrost  | On/High <sup>(a)</sup> | Min  | On   | On   | On  | Off | On    | On    | Off  | Off  |
| 10               | Em. Heat | On/High <sup>(a)</sup> | Min  | Off  | Off  | On  | On  | Off   | Off   | Off  | Off  |

**Note:** Steps for optional accessories and modes not present in unit will be skipped.

<sup>(a)</sup> With optional accessory.

<sup>(b)</sup> Defrost cycle in test mode runs for at least 1 minute, up to 10 minutes, depending on outdoor ambient and outdoor coil temperature.

**Table 56. Test modes for Voyager™ commercial VAV units with IGV/VFD**

| Test Step | Mode                | IGV/VFD                  | Fan               | Econ   | EXH Fan | Power Exhaust Damper | Comp 1             | Comp 2               | HT 1              | HT 2              | Mod. Heat | Cool Valve | Reheat Valve | Reheat Pump Out       | VHR Relay | OHMS |
|-----------|---------------------|--------------------------|-------------------|--------|---------|----------------------|--------------------|----------------------|-------------------|-------------------|-----------|------------|--------------|-----------------------|-----------|------|
| 1         | IGV/VFD Test        | Open/100%                | Off               | Closed | Off     | Min                  | Off                | Off                  | Off               | Off               | 0%        | 100%       | 0%           | Off                   | On        | 2.2k |
| 2         | IGV/VFD Test        | Closed/0%                | OFF               | Closed | Off     | Min                  | Off                | Off                  | Off               | Off               | 0%        | 100%       | 0%           | Off                   | On        | 3.3k |
| 3         | Minimum Ventilation | In Control               | On                | Min    | Off     | Min                  | Off                | Off                  | Off               | Off               | 0%        | 100%       | 0%           | Off                   | On        | 4.7k |
| 4         | Economizer          | In Control               | On                | 100%   | On      | 100%                 | Off                | Off                  | Off               | Off               | 0%        | 100%       | 0%           | Off                   | On        | 6.8k |
| 5         | Cool Stage 1        | In Control               | On                | Min    | Off     | Min                  | On                 | Off                  | Off               | Off               | 0%        | 100%       | 0%           | On/Off <sup>(a)</sup> | On        | 10k  |
| 6         | Cool Stage 2        | In Control               | On                | Min    | Off     | Min                  | Off <sup>(b)</sup> | On <sup>(b)(c)</sup> | Off               | Off               | 0%        | 100%       | 0%           | On                    | On        | 15k  |
| 7         | Cool Stage 3        | In Control               | On                | Min    | Off     | Min                  | On <sup>(c)</sup>  | On <sup>(c)</sup>    | Off               | Off               | 0%        | 100%       | 0%           | On                    | On        | 22k  |
| 8         | Reheat              | In Control               | On <sup>(d)</sup> | Min    | Off     | Min                  | On <sup>(c)</sup>  | On <sup>(c)</sup>    | Off               | Off               | 0%        | 50%        | 50%          | Off                   | On        | 27k  |
| 9         | Heat Stage 1        | Open/100% <sup>(e)</sup> | On <sup>(d)</sup> | Min    | Off     | Min                  | Off                | Off                  | On <sup>(e)</sup> | Off               | 50%       | 100%       | 0%           | Off                   | On        | 33k  |
| 10        | Heat Stage 2        | Open/100% <sup>(e)</sup> | On                | Min    | Off     | Min                  | Off                | Off                  | On <sup>(e)</sup> | On <sup>(e)</sup> | 100%      | 100%       | 0%           | Off                   | On        | 47k  |
| 11        | Reset               |                          |                   |        |         |                      |                    |                      |                   |                   |           |            |              |                       |           |      |

**Notes:**

1. The IGV/VFD will be controlled to the supply pressure setpoint unless test mode has been running for six minutes or longer. After six minutes, the IGV damper will be allowed to drive to 100% for step nine and ten.
2. The exhaust fan will turn on anytime the economizer damper position is equal to or greater than the exhaust fan setpoint. It will not turn off until the economizer damper position is at the exhaust enable setpoint - 10% or lower.
3. The VHR relay output will be energized at the start of the test mode to allow time for the VAV boxes to open. It takes six minutes for the boxes to drive from the full closed position to the full open position. The timing cannot be changed in the field.
4. Economizer, power exhaust damper, HT1, HT2, mod. heat, cool valve, reheat valve, and reheat pump out = with optional feature.

<sup>(a)</sup> 27.5 to 35 (on), 30 to 50 (off).

<sup>(b)</sup> 27.5 to 35 ton units have two stages of mechanical cooling. Both compressors run during cool stage two.

<sup>(c)</sup> The condenser fan will operate any time a compressor is ON providing the outdoor temperatures are within normal operating range.

<sup>(d)</sup> The supply fan will not be allowed to go from an off state to an on state until the IGV are fully closed.

<sup>(e)</sup> The heat outputs will not be allowed to come on until the unit has been in test mode for at least six minutes and the IGV/VFD is at 100%.

**Table 57. CV test modes (also VAV without IGV) 27.5 to 50 tons without reheat**

| Test Step | Mode                 | SF | Econ. | Exh Fan | Power Exh Damper | Comp 1             | Comp 2               | Heat 1 | Heat 2 | Mod Heat | Ohms |
|-----------|----------------------|----|-------|---------|------------------|--------------------|----------------------|--------|--------|----------|------|
| 1         | Minimum Ventilation  | On | Min   | Off     | Min              | Off                | Off                  | Off    | Off    | 0%       | 4.7k |
| 2         | Economizer Test Open | On | 100%  | On      | 100%             | Off                | Off                  | Off    | Off    | 0%       | 6.8k |
| 3         | Cool Stage 1         | On | Min   | Off     | Min              | On <sup>(a)</sup>  | Off                  | Off    | Off    | 0%       | 10k  |
| 4         | Cool Stage 2         | On | Min   | Off     | Min              | Off <sup>(b)</sup> | On <sup>(a)(b)</sup> | Off    | Off    | 0%       | 15k  |
| 5         | Cool Stage 3         | On | Min   | Off     | Min              | On <sup>(a)</sup>  | On <sup>(a)</sup>    | Off    | Off    | 0%       | 22k  |
| 6         | Heat Stage 1         | On | Min   | Off     | Min              | Off                | Off                  | On     | Off    | 50%      | 33k  |
| 7         | Heat Stage 2         | On | Min   | Off     | Min              | Off                | Off                  | On     | On     | 100%     | 47k  |
| 8         | Reset                |    |       |         |                  |                    |                      |        |        |          |      |

**Notes:**

1. Steps for optional accessories and modes not present in unit will be skipped.
2. Economizer, power exhaust damper, heat 1 and 2, and modulating heat = with optional feature.
3. The exhaust fan will turn on anytime the economizer damper position is equal to or greater than the exhaust fan setpoint. It will not turn off until the economizer damper position is at exhaust enable setpoint - 10% or lower.

<sup>(a)</sup> The condenser fans will operate any time a compressor is ON providing the outdoor air temperatures are within normal operating range.

<sup>(b)</sup> 27.5 to 35 ton units have two stages of mechanical cooling. Both compressors run during cool stage two.



**Table 58. CV test modes 27.5 to 50 tons with reheat**

| Test Step | Mode                 | Fan | Econ. | Exh Fan | Power Exh Damper | Comp 1             | Comp 2               | Heat 1 | Heat 2 | Mod Heat | Cool Valve | Reheat Valve | Reheat Pump Out   | Ohms |
|-----------|----------------------|-----|-------|---------|------------------|--------------------|----------------------|--------|--------|----------|------------|--------------|-------------------|------|
| 1         | Minimum Ventilation  | On  | Min   | Off     | Min              | Off                | Off                  | Off    | Off    | 0%       | 100%       | 0%           | Off               | 2.2k |
| 2         | Economizer Test Open | On  | 100%  | On      | 100%             | Off                | Off                  | Off    | Off    | 0%       | 100%       | 0%           | Off               | 3.3k |
| 3         | Cool Stage 1         | On  | Min   | Off     | Min              | On <sup>(a)</sup>  | Off                  | Off    | Off    | 0%       | 100%       | 0%           | Off               | 4.7k |
| 4         | Cool Stage 2         | On  | Min   | Off     | Min              | Off <sup>(b)</sup> | On <sup>(a)(b)</sup> | Off    | Off    | 0%       | 100%       | 0%           | On <sup>(c)</sup> | 6.8k |
| 5         | Cool Stage 3         | On  | Min   | Off     | Min              | On <sup>(a)</sup>  | On <sup>(a)</sup>    | Off    | Off    | 0%       | 100%       | 0%           | On <sup>(c)</sup> | 8.2k |
| 6         | Heat Stage 1         | On  | Min   | Off     | Min              | Off                | Off                  | On     | Off    | 50%      | 100%       | 0%           | Off               | 10k  |
| 7         | Heat Stage 2         | On  | Min   | Off     | Min              | Off                | Off                  | On     | On     | 100%     | 100%       | 0%           | Off               | 15k  |
| 8         | Reheat               | On  | Min   | Off     | Min              | On <sup>(a)</sup>  | On <sup>(a)</sup>    | Off    | Off    | 0%       | 50%        | 50%          | Off               | 33k  |
| 9         | Reset                |     |       |         |                  |                    |                      |        |        |          |            |              |                   |      |

**Notes:**

- Steps for optional accessories and modes not present in unit will be skipped.
  - Economizer, exhaust fan, power exhaust damper, heat 1 and 2, modulating heat, cool valve, reheat valve, and reheat pumpout = with optional feature.
  - The exhaust fan will turn on anytime the economizer damper position is equal to or greater than the exhaust fan setpoint. It will not turn off until the economizer damper position is at exhaust enable setpoint - 10% or lower.
- (a) The condenser fans will operate any time a compressor is ON providing the outdoor air temperatures are within normal operating range.  
 (b) 27.5 to 35 tons units have two stages of mechanical cooling. Both compressors run during cool stage two.  
 (c) The reheat pumpout output will be energized whenever the reheat circuit (circuit 2 for 40 to 50 tons) is energized for cooling operation.

**Table 59. Test mode states for Voyager™ commercial traditional VAV units with modulating dehumidification and staged heat**

| Test Step | Mode            | Fan | VFD Command  | Econ.  | Comp 1 | Comp 2 | Comp 3 | Heat 1 | Heat 2 | Pumpout    | Cool Valve | Reheat Valve | VAV Box |
|-----------|-----------------|-----|--------------|--------|--------|--------|--------|--------|--------|------------|------------|--------------|---------|
| 1         | VFD SIGNAL 100% | OFF | 100% (10VDC) | CLOSED | OFF    | OFF    | OFF    | OFF    | OFF    | OFF        | 100%       | 0%           | ON      |
| 2         | VFD SIGNAL 0%   | OFF | 0% (0 VDC)   | CLOSED | OFF    | OFF    | OFF    | OFF    | OFF    | OFF        | 100%       | 0%           | ON      |
| 3         | MIN VENT        | ON  | IN-CONTROL   | MIN    | OFF    | OFF    | OFF    | OFF    | OFF    | OFF        | 100%       | 0%           | ON      |
| 4         | ECON TEST OPEN  | ON  | IN-CONTROL   | OPEN   | OFF    | OFF    | OFF    | OFF    | OFF    | OFF        | 100%       | 0%           | ON      |
| 5         | COOL 1          | ON  | IN-CONTROL   | MIN    | ON     | OFF    | OFF    | OFF    | OFF    | IN-CONTROL | 100%       | 0%           | ON      |
| 6         | COOL 2          | ON  | IN-CONTROL   | MIN    | ON     | ON     | OFF    | OFF    | OFF    | IN-CONTROL | 100%       | 0%           | ON      |
| 7         | COOL 3          | ON  | IN-CONTROL   | MIN    | ON     | ON     | ON     | OFF    | OFF    | IN-CONTROL | 100%       | 0%           | ON      |
| 8         | REHEAT          | ON  | IN-CONTROL   | MIN    | ON     | ON     | ON     | OFF    | OFF    | IN-CONTROL | 50%        | 50%          | ON      |
| 9         | HEAT 1          | ON  | IN-CONTROL   | MIN    | OFF    | OFF    | OFF    | ON     | OFF    | OFF        | 100%       | 0%           | ON      |
| 10        | HEAT 2          | ON  | IN-CONTROL   | MIN    | OFF    | OFF    | OFF    | ON     | ON     | OFF        | 100%       | 0%           | ON      |
| 11        | RESET           |     |              |        |        |        |        |        |        |            |            |              |         |

**Notes:**

- 2 and 3 stage standard efficiency units: For traditional VAV units, the VFD command when In-Control will be controlled based on supply air pressure requirements. For SZVAV units, the VFD command will be at discrete points during test mode.
- 2 and 3 stage standard efficiency units: For 27.5 to 35 ton units, both compressors will be energized during the Cool 2 step. For 40 to 50 ton units, only Compressor 2 will be energized during the Cool 2 step.
- 2 and 3 stage standard efficiency units: The reheat pumpout relay will be energized any time the reheat circuit is energized in active cooling mode.
- 2 and 3 stage standard efficiency units: For units with Statitrac™ installed, the exhaust damper will track the economizer position during service test mode and the exhaust fan will be energized once the economizer rises above the exhaust enable setpoint.
- 2 and 3 stage standard efficiency units: Heating will not be energized during service test until the 6 minute VAV box ON timer has expired.
- 5 stage high efficiency units: Compressor 1 is the smaller compressor on the circuit.
- 5 stage high efficiency units: Condenser fans are controlled as defined for normal operation.
- 5 stage high efficiency units: Exhaust fan operates as defined for normal operation based on economizer position.
- 5 stage high efficiency units: When compressor 1 is energized with either C1, C2, or with both for 30 minutes continuously, C3 will be required to de-energize for 30 seconds.

**Table 60. Test mode states for Voyager™ commercial CV units with modulating dehumidification and staged heat**

| Test Step | Mode       | Fan | Econ. | Comp 1 | Comp 2 | Comp 3 | Heat 1 | Heat 2 | Pumpout    | Cool Valve | Reheat Valve | VAV Box |
|-----------|------------|-----|-------|--------|--------|--------|--------|--------|------------|------------|--------------|---------|
| 1         | FAN ON     | ON  | MIN   | OFF    | OFF    | OFF    | OFF    | OFF    | OFF        | 100%       | 0%           | ON      |
| 2         | ECONOMIZER | ON  | OPEN  | OFF    | OFF    | OFF    | OFF    | OFF    | OFF        | 100%       | 0%           | ON      |
| 3         | COOL 1     | ON  | MIN   | ON     | OFF    | OFF    | OFF    | OFF    | IN-CONTROL | 100%       | 0%           | ON      |
| 4         | COOL 2     | ON  | MIN   | ON     | ON     | OFF    | OFF    | OFF    | IN-CONTROL | 100%       | 0%           | ON      |
| 5         | COOL 3     | ON  | MIN   | ON     | ON     | ON     | OFF    | OFF    | IN-CONTROL | 100%       | 0%           | ON      |
| 6         | REHEAT     | ON  | MIN   | ON     | ON     | ON     | OFF    | OFF    | IN-CONTROL | 50%        | 50%          | ON      |
| 7         | HEAT 1     | ON  | MIN   | OFF    | OFF    | OFF    | ON     | OFF    | OFF        | 100%       | 0%           | ON      |
| 8         | HEAT 2     | ON  | MIN   | OFF    | OFF    | OFF    | ON     | ON     | OFF        | 100%       | 0%           | ON      |
| 9         | RESET      |     |       |        |        |        |        |        |            |            |              |         |

**Notes:**

- 2 and 3 stage standard efficiency units: For 27.5 to 35 ton units, both compressors will be energized during the Cool 2 step. For 40 to 50 ton units, only Compressor 2 will be energized during the Cool 2 step.
- 2 and 3 stage standard efficiency units: The reheat pumpout relay will be energized any time the reheat circuit is energized in active cooling mode.
- 2 and 3 stage standard efficiency units: For units with Statitrac™ installed, the exhaust damper will track the economizer position during service test mode and the exhaust fan will be energized once the economizer rises above the exhaust enable setpoint.
- 2 and 3 stage standard efficiency units: Heating will not be energized during service test until the 6 minute VAV box ON timer has expired.
- 5 stage high efficiency units: Compressor 1 is the smaller compressor on the circuit.
- 5 stage high efficiency units: Condenser fans are controlled as defined for normal operation.
- 5 stage high efficiency units: Exhaust fan operates as defined for normal operation based on economizer position.
- 5 stage high efficiency units: When compressor 1 is energized with either C1, C2, or with both for 30 minutes continuously, C3 will be required to de-energize for 30 seconds.

**Table 61. Test mode states for Voyager™ commercial SZ VAV units with modulating dehumidification and staged heat**

| Test Step | Mode       | Fan | VFD Command    | Econ. | Comp 1 | Comp 2 | Comp 3 | Heat 1 | Heat 2 | Pumpout    | Cool Valve | Reheat Valve |
|-----------|------------|-----|----------------|-------|--------|--------|--------|--------|--------|------------|------------|--------------|
| 1         | FAN ON     | ON  | 45% (0 VDC)    | MIN   | OFF    | OFF    | OFF    | OFF    | OFF    | OFF        | 100%       | 0%           |
| 2         | ECONOMIZER | ON  | 45% (0 VDC)    | OPEN  | OFF    | OFF    | OFF    | OFF    | OFF    | OFF        | 100%       | 0%           |
| 3         | COOL 1     | ON  | 80% (6.67 VDC) | MIN   | ON     | OFF    | OFF    | OFF    | OFF    | IN-CONTROL | 100%       | 0%           |
| 4         | COOL 2     | ON  | IN-CONTROL     | MIN   | ON     | ON     | OFF    | OFF    | OFF    | IN-CONTROL | 100%       | 0%           |
| 5         | COOL 3     | ON  | IN-CONTROL     | MIN   | ON     | ON     | ON     | OFF    | OFF    | IN-CONTROL | 100%       | 0%           |
| 6         | REHEAT     | ON  | 73% (5.24 VDC) | MIN   | ON     | ON     | ON     | OFF    | OFF    | IN-CONTROL | 50%        | 50%          |
| 7         | HEAT 1     | ON  | 100% (10 VDC)  | MIN   | OFF    | OFF    | OFF    | ON     | OFF    | OFF        | 100%       | 0%           |
| 8         | HEAT 2     | ON  | 100% (10 VDC)  | MIN   | OFF    | OFF    | OFF    | ON     | ON     | OFF        | 100%       | 0%           |
| 9         | RESET      |     |                |       |        |        |        |        |        |            |            |              |

**Notes:**

- 2 and 3 stage standard efficiency units: For traditional VAV units, the VFD command when In-Control will be controlled based on supply air pressure requirements. For SZVAV units, the VFD command will be at discrete points during test mode.
- 2 and 3 stage standard efficiency units: For 27.5 to 35 ton units, both compressors will be energized during the Cool 2 step. For 40 to 50 ton units, only Compressor 2 will be energized during the Cool 2 step.
- 2 and 3 stage standard efficiency units: The reheat pumpout relay will be energized any time the reheat circuit is energized in active cooling mode.
- 2 and 3 stage standard efficiency units: For units with Statitrac™ installed, the exhaust damper will track the economizer position during service test mode and the exhaust fan will be energized once the economizer rises above the exhaust enable setpoint.
- 5 stage high efficiency units: Compressor 1 is the smaller compressor on the circuit.
- 5 stage high efficiency units: Condenser fans are controlled as defined for normal operation.
- 5 stage high efficiency units: Exhaust fan operates as defined for normal operation based on economizer position.
- 5 stage high efficiency units: When compressor 1 is energized with either C1, C2, or with both for 30 minutes continuously, C3 will be required to de-energize for 30 seconds.

**Table 62. Test mode states for traditional Voyager™ commercial VAV units with modulating dehumidification and modulating heat**

| Test Step | Mode            | Fan | VFD Command  | Econ.  | Comp 1 | Comp 2 | Comp 3 | Heat Output | Pumpout | Cool Valve | Reheat Valve | VAV Box |
|-----------|-----------------|-----|--------------|--------|--------|--------|--------|-------------|---------|------------|--------------|---------|
| 1         | VFD SIGNAL 100% | OFF | 100% (10VDC) | CLOSED | OFF    | OFF    | OFF    | OFF         | OFF     | 100%       | 0%           | ON      |
| 2         | VFD SIGNAL 0%   | OFF | 0% (0 VDC)   | CLOSED | OFF    | OFF    | OFF    | OFF         | OFF     | 100%       | 0%           | ON      |

**Table 62. Test mode states for traditional Voyager™ commercial VAV units with modulating dehumidification and modulating heat (continued)**

| Test Step | Mode           | Fan | VFD Command | Econ. | Comp 1 | Comp 2 | Comp 3 | Heat Output | Pumpout    | Cool Valve | Reheat Valve | VAV Box |
|-----------|----------------|-----|-------------|-------|--------|--------|--------|-------------|------------|------------|--------------|---------|
| 3         | MIN VENT       | ON  | IN-CONTROL  | MIN   | OFF    | OFF    | OFF    | OFF         | OFF        | 100%       | 0%           | ON      |
| 4         | ECON TEST OPEN | ON  | IN-CONTROL  | OPEN  | OFF    | OFF    | OFF    | OFF         | OFF        | 100%       | 0%           | ON      |
| 5         | COOL 1         | ON  | IN-CONTROL  | MIN   | ON     | OFF    | OFF    | OFF         | IN-CONTROL | 100%       | 0%           | ON      |
| 6         | COOL 2         | ON  | IN-CONTROL  | MIN   | ON     | ON     | OFF    | OFF         | IN-CONTROL | 100%       | 0%           | ON      |
| 7         | COOL 3         | ON  | IN-CONTROL  | MIN   | ON     | ON     | ON     | OFF         | IN-CONTROL | 100%       | 0%           | ON      |
| 8         | REHEAT         | ON  | IN-CONTROL  | MIN   | ON     | ON     | ON     | OFF         | IN-CONTROL | 50%        | 50%          | ON      |
| 9         | HEAT 1         | ON  | IN-CONTROL  | MIN   | OFF    | OFF    | OFF    | 50%         | OFF        | 100%       | 0%           | ON      |
| 10        | HEAT 2         | ON  | IN-CONTROL  | MIN   | OFF    | OFF    | OFF    | 100%        | OFF        | 100%       | 0%           | ON      |
| 11        | RESET          |     |             |       |        |        |        |             |            |            |              |         |

**Notes:**

- 2 and 3 stage standard efficiency units: For traditional VAV units, the VFD Command when In-Control will be controlled based on supply air pressure requirements. For SZVAV units, the VFD command will be at discrete points during test mode.
- 2 and 3 stage standard efficiency units: For 27.5 to 35 ton units, both compressors will be energized during the Cool 2 step. For 40 to 50 ton units, only Compressor 2 will be energized during the Cool 2 step.
- 2 and 3 stage standard efficiency units: The reheat pumpout relay will be energized any time the reheat circuit is energized in active cooling mode.
- 2 and 3 stage standard efficiency units: For units with Statitrac™ installed, the exhaust damper will track the economizer position during service test mode and the exhaust fan will be energized once the economizer rises above the exhaust enable setpoint.
- 2 and 3 stage standard efficiency units: Heating will not be energized during service test until the 6 minute VAV box ON timer has expired.
- 5 stage high efficiency units: Compressor 1 is the smaller compressor on the circuit.
- 5 stage high efficiency units: Condenser fans are controlled as defined for normal operation.
- 5 stage high efficiency units: Exhaust fan operates as defined for normal operation based on economizer position.
- 5 stage high efficiency units: When compressor 1 is energized with either C1, C2, or with both for 30 minutes continuously, C3 will be required to de-energize for 30 seconds.

**Table 63. Test mode states for Voyager™ commercial CV units with modulating dehumidification and modulating heat**

| Test Step | Mode       | Fan | Econ. | Comp 1 | Comp 2 | Comp 3 | Heat Output | Pumpout    | Cool Valve | Reheat Valve | VAV Box |
|-----------|------------|-----|-------|--------|--------|--------|-------------|------------|------------|--------------|---------|
| 1         | FAN ON     | ON  | MIN   | OFF    | OFF    | OFF    | OFF         | OFF        | 100%       | 0%           | ON      |
| 2         | ECONOMIZER | ON  | OPEN  | OFF    | OFF    | OFF    | OFF         | OFF        | 100%       | 0%           | ON      |
| 3         | COOL 1     | ON  | MIN   | ON     | OFF    | OFF    | OFF         | IN-CONTROL | 100%       | 0%           | ON      |
| 4         | COOL 2     | ON  | MIN   | ON     | ON     | OFF    | OFF         | IN-CONTROL | 100%       | 0%           | ON      |
| 5         | COOL 3     | ON  | MIN   | ON     | ON     | ON     | OFF         | IN-CONTROL | 100%       | 0%           | ON      |
| 6         | REHEAT     | ON  | MIN   | ON     | ON     | ON     | OFF         | IN-CONTROL | 50%        | 50%          | ON      |
| 7         | HEAT 1     | ON  | MIN   | OFF    | OFF    | OFF    | 50%         | OFF        | 100%       | 0%           | ON      |
| 8         | HEAT 2     | ON  | MIN   | OFF    | OFF    | OFF    | 100%        | OFF        | 100%       | 0%           | ON      |
| 9         | RESET      |     |       |        |        |        |             |            |            |              |         |

**Notes:**

- 2 and 3 stage standard efficiency units: For 27.5 to 35 ton units, both compressors will be energized during the Cool 2 step. For 40 to 50 ton units, only Compressor 2 will be energized during the Cool 2 step.
- 2 and 3 stage standard efficiency units: The reheat pumpout relay will be energized any time the reheat circuit is energized in active cooling mode.
- 2 and 3 stage standard efficiency units: For units with Statitrac™ installed, the exhaust damper will track the economizer position during service test mode and the exhaust fan will be energized once the economizer rises above the exhaust enable setpoint.
- 2 and 3 stage standard efficiency units: Heating will not be energized during service test until the 6 minute VAV box ON timer has expired.
- 5 stage high efficiency units: Compressor 1 is the smaller compressor on the circuit.
- 5 stage high efficiency units: Condenser fans are controlled as defined for normal operation.
- 5 stage high efficiency units: Exhaust fan operates as defined for normal operation based on economizer position.
- 5 stage high efficiency units: When compressor 1 is energized with either C1, C2, or with both for 30 minutes continuously, C3 will be required to de-energize for 30 seconds.

**Table 64. Test mode states for Voyager™ commercial SZVAV units with modulating dehumidification and modulating heat**

| Test Step | Mode       | Fan | VFD Command    | Econ. | Comp 1 | Comp 2 | Comp 3 | Heat Output | Pumpout    | Cool Valve | Reheat Valve |
|-----------|------------|-----|----------------|-------|--------|--------|--------|-------------|------------|------------|--------------|
| 1         | FAN ON     | ON  | 45% (0 VDC)    | MIN   | OFF    | OFF    | OFF    | OFF         | OFF        | 100%       | 0%           |
| 2         | ECONOMIZER | ON  | 45% (0 VDC)    | OPEN  | OFF    | OFF    | OFF    | OFF         | OFF        | 100%       | 0%           |
| 3         | COOL 1     | ON  | 80% (6.67 VDC) | MIN   | ON     | OFF    | OFF    | OFF         | IN-CONTROL | 100%       | 0%           |
| 4         | COOL 2     | ON  | IN-CONTROL     | MIN   | ON     | ON     | OFF    | OFF         | IN-CONTROL | 100%       | 0%           |
| 5         | COOL 3     | ON  | IN-CONTROL     | MIN   | ON     | ON     | ON     | OFF         | IN-CONTROL | 100%       | 0%           |
| 6         | REHEAT     | ON  | 73% (5.24 VDC) | MIN   | ON     | ON     | ON     | OFF         | IN-CONTROL | 50%        | 50%          |
| 7         | HEAT 1     | ON  | 100% (10 VDC)  | MIN   | OFF    | OFF    | OFF    | 50%         | OFF        | 100%       | 0%           |
| 8         | HEAT 2     | ON  | 100% (10 VDC)  | MIN   | OFF    | OFF    | OFF    | 100%        | OFF        | 100%       | 0%           |
| 9         | RESET      |     |                |       |        |        |        |             |            |            |              |

**Notes:**

- 2 and 3 stage standard efficiency units: For traditional VAV units, the VFD command when In-Control will be controlled based on supply air pressure requirements. For SZVAV units, the VFD command will be at discrete points during test mode.
- 2 and 3 stage standard efficiency units: For 27.5 to 35 ton units, both compressors will be energized during the Cool 2 step. For 40 to 50 ton units, only Compressor 2 will be energized during the Cool 2 step.
- 2 and 3 stage standard efficiency units: The reheat pumpout relay will be energized any time the reheat circuit is energized in active cooling mode.
- 2 and 3 stage standard efficiency units: For units with Statitrac™ installed, the exhaust damper will track the Economizer position during service test mode and the exhaust fan will be energized once the economizer rises above the exhaust enable setpoint.
- 5 stage high efficiency units: Compressor 1 is the smaller compressor on the circuit.
- 5 stage high efficiency units: Condenser fans are controlled as defined for normal operation.
- 5 stage high efficiency units: Exhaust fan operates as defined for normal operation based on economizer position.
- 5 stage high efficiency units: When compressor 1 is energized with either C1, C2, or with both for 30 minutes continuously, C3 will be required to de-energize for 30 seconds.

## Units with Two Heat Exchangers (High Heat Models)

Heat Stage one - The two stage burner runs high heat for 60 seconds, then drops to low heat. Modulating gas heat stays off.

Heat Stage two - The two stage burner stays on low. Modulating burner comes on and stays at 100%.

**Table 65. Sequence of operation reference**

| Product Family            | Publication Number   | Short Description  |
|---------------------------|----------------------|--|
| Odyssey™                  | SSA-SVX06*-EN        | Split System Air Handlers 5 to 25 Tons                                   |
| Odyssey™                  | SS-SVX10*-EN         | Split System Cooling Condensers 6 to 25 Tons                             |
| Odyssey™                  | SSP-SVX14*-EN        | Split System Heat Pump Condensers, R-410A 6 to 20 Tons                   |
| Odyssey™                  | SSP-SVX15*-EN        | Split System Heat Pump Condensers R-22 Dry Charge 7.5 and 10 Tons, 60 Hz |
| Odyssey™                  | SS-SVX12*-EN         | Split System Cooling Condensers R-22 Dry Charge 7.5 and 10 Tons, 60 Hz   |
| Precedent™                | Refer to Product IOM |  |
| Voyager™ Light Commercial | Refer to Product IOM |  |
| Voyager™ Commercial       | RT-SVX34*-EN         | Voyager™ Commercial - 27.5 to 50 Tons, 60 Hz                             |

## ReliaTel™ Service Test

**Table 66. Single zone VAV heat pump units with staged and modulating auxiliary heating**

| Step | Description           | RTRM Supply Fan Output | RTOM Fan Speed Output (VFD/ERM BC Plenum/Standard PWM) | RTOM Fan Speed Output (17 SEER) |
|------|-----------------------|------------------------|--|---------------------------------|
| 1    | Fan On                | ON                     | MIN  | NA <sup>(a)</sup>               |
| 2    | Econ                  | ON                     | MIN  |                                 |
| 3    | Cool 1                | ON                     | 67% (82% for ERM)                                      |                                 |
| 4    | Cool 2 <sup>(b)</sup> | ON                     | MAX (100%)   |                                 |
| 5    | Cool 3                | ON                     | MAX (100%)   |                                 |
| 6    | Heat 1                | ON                     | MAX (100%)   |                                 |
| 7    | Heat 2                | ON                     | MAX (100%)   |                                 |
| 8    | Heat 3                | ON                     | MAX (100%)   |                                 |
| 9    | Heat 4                | ON                     | MAX (100%)   |                                 |
| 10   | Defrost               | ON                     | MAX (100%)   |                                 |
| 11   | Em Heat               | ON                     | MAX (100%)   |                                 |

**Note:** For all of the service test steps in which the fan speed output is at MIN, the fan speed will be at the minimum speed for the associated step.

<sup>(a)</sup> 17 SEER units cannot be configured as heat pumps.

<sup>(b)</sup> For units configured with two steps of mechanical cooling, the unit will energize the supply fan and ramp the output up to 100% for the associated Cool 2 step in service test.

**Table 67. Single zone VAV non-heat pump units with staged heating**

| Step | Description           | RTRM Supply Fan Output | RTOM Fan Speed Output (VFD/Standard PWM) | RTOM Fan Speed Output (17 SEER PWM/ERM BC Plenum) |
|------|-----------------------|------------------------|--|---|
| 1    | Fan On                | ON                     | MIN                                      | MIN   |
| 2    | Econ                  | ON                     | MIN                                      | MIN   |
| 3    | Cool 1                | ON                     | 67%                                      | 82% <sup>(a)</sup>                                |
| 4    | Cool 2 <sup>(b)</sup> | ON                     | MAX (100%)                               | 100%  |
| 5    | Cool 3 <sup>(c)</sup> | ON                     | MAX (100%)                               | NA  |
| 6    | Reheat <sup>(d)</sup> | ON                     | 80%                                      | MAX (100%)  |
| 7    | Heat 1                | ON                     | MAX (100%)                               | MAX (100%)  |
| 8    | Heat 2                | ON                     | MAX (100%)                               | MAX (100%)  |

**Note:** For all of the service test steps in which the fan speed output is at MIN, the fan speed will be at the minimum speed for the associated step.

<sup>(a)</sup> 82% chosen in order to give the user the ability to have a service test step for setting up proper OA damper position setpoints.

<sup>(b)</sup> For units configured with two steps of mechanical cooling, the unit will energize the supply fan and ramp the output up to 100% for the associated Cool 2 step in service test.

<sup>(c)</sup> 17 SEER units cannot have 3-step cooling.

<sup>(d)</sup> Reheat step only performed on units configured for HGRH, not for enhanced dehumidification only.

**Table 68. Single zone VAV non-heat pump units with modulating heat types**

| Step | Description                            | RTRM Supply Fan Output | RTOM Fan Speed Output (VFD/Standard PWM) | RTOM Fan Speed Output (17 SEER PWM/ERM BC Plenum) |
|------|--|------------------------|--|---|
| 1    | Fan On                                 | ON                     | MIN                                      | MIN   |
| 2    | Econ                                   | ON                     | MIN                                      | MIN   |
| 3    | Cool 1                                 | ON                     | 67%                                      | 82% <sup>(a)</sup>                                |
| 4    | Cool 2 <sup>(b)</sup>                  | ON                     | MAX (100%)                               | MAX (100%)  |
| 5    | Cool 3 <sup>(c)</sup>                  | ON                     | MAX (100%)                               | NA  |
| 6    | Reheat <sup>(d)</sup>                  | ON                     | 80%                                      | MAX (100%)  |
| 7    | Heat 1 (Mod Heat = 50%) <sup>(e)</sup> | ON                     | MIN                                      | MIN <sup>(f)</sup>                                |
| 8    | Heat 2 (Mod Heat = 100%)               | ON                     | MAX (100%)                               | MAX (100%)  |

**Note:** For all of the service test steps in which the fan speed output is at MIN, the fan speed will be at the minimum speed for the associated step.

- (a) 82% chosen in order to give the user the ability to have a service test step for setting up proper OA damper position setpoints.
- (b) For units configured with two steps of mechanical cooling, the unit will energize the supply fan and ramp the output up to 100% for the associated Cool 2 step in service test.
- (c) 17 SEER units cannot have 3-step cooling.
- (d) Reheat step only performed on units configured for HGRH, not for enhanced dehumidification only.
- (e) The minimum speed output may be 100% if the unit is configured for CV heating control.
- (f) Precedent™ 17 SEER units do not currently support modulating heat as a heating type, so the minimum speed has not been defined based on product requirements.

The following table shows the unit operation during normal test mode. As on non-VSPD compressor equipped units, service test mode can be initiated by shorting the service

test pins on the RTRM or by applying the appropriate resistor value for the modes listed below.

**Table 69. Precedent™ 3 to 10 tons SZVAV eFlex™**

| Test Step | Fan On/OFF | Supply Fan% Output | Econ. | VSPD Compressor Capacity Output | Outdoor Fan PWM Output | Test Step Resistance (Ohms) |
|-----------|------------|--------------------|-------|---------------------------------|------------------------|-----------------------------|
| Fan On    | ON         | 50%                | MIN   | 0%                              | 0%                     | 2.2K                        |
| Econ      | ON         | 50%                | OPEN  | 0%                              | 0%                     | 3.3K                        |
| Cool 1    | ON         | 82%                | MIN   | 50%                             | <sup>(a)</sup>         | 4.7K                        |
| Cool 2    | ON         | 100%               | MIN   | 100%                            | <sup>(a)</sup>         | 6.8K                        |
| Heat 1    | ON         | 100%               | MIN   | 0%                              | 0%                     | 10K                         |
| Heat 2    | ON         | 100%               | MIN   | 0%                              | 0%                     | 15K                         |

**Notes:**

1. The supply fan % output is in reference to the user selected maximum unit fan speed. Unit will operate at 100% fan speed during heating unless configured for SZVAV heating operation.
  2. The supply fan and compressor outputs shall follow all startup and shutdown requirements prior to moving through test mode steps that change the states of the compressor output from ON to OFF or OFF to ON.
  3. All compressor% outputs are in reference to the 100% capacity point per unit tonnage.
- (a) Condenser fan operation will be controlled based on the active OAT as during normal operation.

**Table 70. Precedent™ 3 to 10 tons MZVAV eFlex™**

| Test Step      | Fan ON/Off | Supply Fan % Output       | IGV Output        | Econ   | VSPD Comp Capacity Output | Outdoor Fan PWM Output | VAV Box | Test Step Resistance (Ohms) |
|----------------|------------|---------------------------|-------------------|--------|---------------------------|------------------------|---------|-----------------------------|
| IGV Open Test  | OFF        | 0% Duty Cycle             | 0% <sup>(a)</sup> | Closed | 0%                        | 0%                     | ON      | 2.2K                        |
| IGV Close Test | OFF        | 0% Duty Cycle             | 0%                | Closed | 0%                        | 0%                     | ON      | 3.3K                        |
| Fan On         | ON         | IN-CONTROL <sup>(b)</sup> | N/A               | MIN    | 0%                        | 0%                     | ON      | 4.7K                        |
| Econ           | ON         | IN-CONTROL <sup>(b)</sup> | N/A               | OPEN   | 0%                        | 0%                     | ON      | 6.8K                        |
| Cool 1         | ON         | IN-CONTROL <sup>(b)</sup> | N/A               | MIN    | 50%                       | <sup>(c)</sup>         | ON      | 10K                         |
| Cool 2         | ON         | IN-CONTROL <sup>(b)</sup> | N/A               | MIN    | 100%                      | <sup>(c)</sup>         | ON      | 15K                         |
| Heat 1         | ON         | 100% <sup>(d)</sup>       | N/A               | MIN    | 0%                        | 0%                     | ON      | 33K                         |
| Heat 2         | ON         | 100% <sup>(d)</sup>       | N/A               | MIN    | 0%                        | 0%                     | ON      | 47K                         |

**Notes:**

- The supply fan % output is in reference to the user selected maximum unit fan speed.
  - The supply fan and compressor outputs shall follow all startup and shutdown requirements prior to moving through test mode steps that change the states of the compressor output from ON to OFF or OFF to ON.
  - All compressor % outputs are in reference to the 100% capacity point per unit tonnage.
- <sup>(a)</sup> During step 1 of the short-circuit based service test sequence; the IGV output is driven to 0%. However, for the 2.2kOhm resistance based service test step approach - the IGV output is driven to 100%.
- <sup>(b)</sup> For multi-zone VAV units, the VFD command when In-Control will be controlled based on supply air pressure requirements for the unit.
- <sup>(c)</sup> Condenser fan operation will be controlled based on the active OAT as during normal operation.
- <sup>(d)</sup> VAV boxes are commanded to an open position during service test. However, six minutes must be allowed for the VAV boxes to reach a fully opened position. During these 1st six minutes, duct static pressure control has control priority over the supply fan command of 100%.

**Table 71. Voyager™ light commercial 12.5 to 17.5 tons SZVAV eFlex™**

| Test Step | Fan On/OFF | Supply Fan % Output    | Econ | VSPD Compr Capacity Output | Fixed Comp 1 | Fixed Comp 2 | Outdoor Fan PWM Output | Test Step Resistance (Ohms) |
|-----------|------------|------------------------|------|----------------------------|--------------|--------------|------------------------|-----------------------------|
| Fan On    | ON         | 0%/25% <sup>(a)</sup>  | MIN  | 0%                         | OFF          | OFF          | 0%                     | 2.2K                        |
| Econ      | ON         | 0%/25% <sup>(a)</sup>  | OPEN | 0%                         | OFF          | OFF          | 0%                     | 3.3K                        |
| Cool 1    | ON         | 67%/75% <sup>(a)</sup> | MIN  | 50%                        | OFF          | OFF          | <sup>(b)</sup>         | 4.7K                        |
| Cool 2    | ON         | 100%                   | MIN  | 100%                       | ON           | OFF          | <sup>(b)</sup>         | 6.8K                        |
| Cool 3    | ON         | 100%                   | MIN  | 100%                       | ON           | ON           | <sup>(b)</sup>         | 8.2K                        |
| Heat 1    | ON         | 100%                   | MIN  | 0%                         | OFF          | OFF          | 0%                     | 10K                         |
| Heat 2    | ON         | 100%                   | MIN  | 0%                         | OFF          | OFF          | 0%                     | 15K                         |

**Notes:**

- The supply fan % output is in reference to the user selected maximum unit fan speed. Unit will operate at 100% fan speed during heating unless configured for SZVAV heating operation.
  - The supply fan and compressor outputs shall follow all startup and shutdown requirements prior to moving through test mode steps that change the states of the compressor output from ON to OFF or OFF to ON.
  - All compressor % outputs are in reference to the 100% capacity point per unit tonnage.
- <sup>(a)</sup> First % shown is the control signal percentage. Second % is the actual fan speed percentage.
- <sup>(b)</sup> Condenser fan operation will be controlled based on the active OAT as during normal operation.

**Table 72. Voyager™ light commercial 12.5 to 17.5 tons MZVAV eFlex™**

| Test Step      | Supply Fan % Output       | IGV Output        | Econ   | VSPD Comp Capacity Output | Fixed Comp 1 | Fixed Comp 2 | Outdoor Fan PWM Output | VAV Box | Test Step Resistance (Ohms) |
|----------------|---------------------------|-------------------|--------|---------------------------|--------------|--------------|------------------------|---------|-----------------------------|
| IGV Open Test  | 0% (Fan State: Off)       | 0% <sup>(a)</sup> | Closed | 0%                        | OFF          | OFF          | 0%                     | ON      | 2.2k                        |
| IGV Close Test | 0% (Fan State: Off)       | 0%                | Closed | 0%                        | OFF          | OFF          | 0%                     | ON      | 3.3k                        |
| Fan On         | In-Control <sup>(b)</sup> | N/A               | MIN    | 0%                        | OFF          | OFF          | 0%                     | ON      | 4.7k                        |
| Econ           | In-Control                | N/A               | OPEN   | 0%                        | OFF          | OFF          | 0%                     | ON      | 6.8k                        |
| Cool 1         | In-Control                | N/A               | MIN    | 50%                       | OFF          | OFF          | <sup>(c)</sup>         | ON      | 10k                         |
| Cool 2         | In-Control                | N/A               | MIN    | 100%                      | ON           | OFF          | <sup>(c)</sup>         | ON      | 15k                         |
| Cool 3         | In-Control                | N/A               | MIN    | 100%                      | ON           | ON           | <sup>(c)</sup>         | ON      | 22k                         |

**Table 72. Voyager™ light commercial 12.5 to 17.5 tons MZVAV eFlex™ (continued)**

| Test Step | Supply Fan % Output | IGV Output | Econ | VSPD Comp Capacity Output | Fixed Comp 1 | Fixed Comp 2 | Outdoor Fan PWM Output | VAV Box | Test Step Resistance (Ohms) |
|-----------|---------------------|------------|------|---------------------------|--------------|--------------|------------------------|---------|-----------------------------|
| Heat 1    | 100% <sup>(c)</sup> | N/A        | MIN  | 0%                        | OFF          | OFF          | 0%                     | ON      | 33k                         |
| Heat 2    | 100% <sup>(c)</sup> | N/A        | MIN  | 0%                        | OFF          | OFF          | 0%                     | ON      | 47k                         |

**Notes:**

1. The supply fan % output is in reference to the user selected maximum unit fan speed. Unit will operate at 100% fan speed during heating unless configured for MZVAV heating operation.
  2. The supply fan and compressor outputs shall follow all startup and shutdown requirements prior to moving through test mode steps that change the states of the compressor output from ON to OFF or OFF to ON.
  3. All compressor % outputs are in reference to the 100% capacity point per unit tonnage.
- (a) During step 1 of the short-circuit based service test sequence; the IGV output is driven to 0%. However, for the 2.2kOhm resistance based service test step approach - the IGV output is driven to 100%.
- (b) For multi-zone VAV units, the VFD command when In-Control will be controlled based on supply air pressure requirements for the unit.
- (c) VAV boxes are commanded to an open position during service test. However, six minutes must be allowed for the VAV boxes to reach a fully opened position. During these 1st six minutes, duct static pressure control has control priority over the supply fan command of 100%.

Service test mode for units with two-speed indoor fan control will control the indoor fan as is controlled during normal unit operations during its corresponding step in service test mode. Refer to the table below for additional information on unit operation during service test.

**Table 73. Unit operation during service test**

| Test Step | Fan Speed Output |
|-----------|------------------|
| Fan On    | Low              |
| Econ      | Low              |
| Cool 1    | Low              |
| Cool 2    | Low              |
| Cool 3    | High             |

**Table 73. Unit operation during service test (continued)**

| Test Step                           | Fan Speed Output |
|-------------------------------------|------------------|
| Heat 1                              | High             |
| Heat 2                              | High             |
| Heat 3                              | High             |
| Heat 4                              | High             |
| Defrost or Dehumidification/ Reheat | High             |
| Em. Heat                            | High             |



# Thermostats and Sensors

## Protocol of Communications

It is possible, though not recommended, to connect multiple control devices to a ReliaTel™ system. The terminal strip is arranged such that simultaneous connection of ICS communication (Tracker®, Tracer®, Summit, VariTrac®), mechanical zone sensor module

(ZSM), programmable zone sensor, and a conventional thermostat is possible. Only one device can control the unit at a time. Following is a protocol of communication; if communication fails, the RTRM seeks the next lower priority level device. If no device is connected, the unit will not run except during the **test mode**.

|                  |   |
|------------------|---|
| Highest priority | ICS (Tracker®, Tracer®, Summit, VariTrac®) - Using BAYSENS013, 014, 017 as needed |
| Next priority    | Programmable Zone Sensor (BAYSENS119, AYSTAT666, BAYSENS020)                      |
| Next priority    | Mechanical ZSM (BAYSENS006-11B, AYSTAT661-664)                                    |
| Least priority   | Conventional Thermostat (R, G, Y, W, C)   |

It is possible to connect multiple devices. Doing so increases the chance for error in application and troubleshooting.

**Note:** 27.5 to 50 tons VAV conventional thermostat inputs do not work and are ignored by the RTRM.

On power up, the RTRM looks for a zone temperature input (J6-1, J6-2). If it doesn't see one, it then ignores zone sensor inputs and looks for thermostat (RGYW) inputs.

If the unit does see a valid zone temperature input on startup then the thermostat (RGYW) inputs are ignored. A programmable zone sensor will take priority over either input when connected, and an ICS system takes the highest priority.

**Table 74. Thermostat and sensor descriptions**

| Accessory Model #       | Zone Sensor Module Description                              | Required # Conductors | Terminal Connections at J6            |
|-------------------------|---|-----------------------|---------------------------------------|
| <b>Heat/Cool</b>        |   |                       |                                       |
| BAYSENS106*/ASYSTAT106* | Single Set Point/Manual Changeover                          | 4                     | 1,2,3,4                               |
| BAYSENS108*             | Dual Set Point Manual/Auto Changeover                       | 5                     | 1,2,3,4,5                             |
| BAYSENS110*/ASYSTAT111* | Dual Set Point with LEDs Manual/Auto Changeover             | 10                    | 1,2,3,4,5,6,7,8,9,10                  |
| BAYSENS119*/ASYSTAT666* | Programmable with Night Setback and LCD Indicators          | 3-7                   | 7,8,9,10,11,12,14 (7-10 are optional) |
| BAYSENS077*             | Remote Sensor   | 2                     | 1,2                                   |
| BAYSENS135*/ASYSTAT709A | Digital Dual Setpoint with Manual /Auto Changeover          | 11                    | 1,2,3,4,5,6,7,8,9,10                  |
| BAYSENS924*             | Touch Screen Programmable Zone Sensor                       | 5-7                   | 11,14                                 |
| <b>Heat Pump</b>        |   |                       |                                       |
| BAYSENS107*/ASYSTAT107* | Single Set Point Manual Changeover                          | 6                     | 1,2,3,4,5,6,7                         |
| BAYSENS109*/ASYSTAT109* | Dual Set Point with LEDs Manual/Auto Changeover             | 10                    | 1,2,3,4,5,6,7,8,9,10                  |
| BAYSENS119*/ASYSTAT666* | Programmable with Night Setback and LCD Indicators          | 3-7                   | 7,8,9,10,11,12,14 (7-10 are optional) |
| BAYSENS077*             | Remote sensor   | 2                     | 1,2                                   |
| BAYSENS031*             | Digital Heat Pump Dual Setpoint with Manual/Auto Changeover | 11                    |                                       |

Table 74. Thermostat and sensor descriptions (continued)

| Accessory Model #            | Zone Sensor Module Description                      | Required # Conductors | Terminal Connections at J6            |
|------------------------------|---|-----------------------|---------------------------------------|
| BAYSENS924*                  | Touch Screen Programmable Zone Sensor               | 5-7                   | 11,14                                 |
| <b>MZVAV 27.5 to 50 tons</b> |   |                       |                                       |
| BAYSENS119*                  | Programmable with Night Setback and LCD indicators  | 3-7                   | 7,8,9,10,11,12,14 (7-10 are optional) |
| BAYSENS021                   | VAV Setpoint Panel w/LED's                          | 9                     | 1,2,3,4,6,7,8,9,10                    |
| <b>Tracer®/Tracker® ICS</b>  |   |                       |                                       |
| BAYSENS073*                  | Override Sensor with Override / Cancel              | 2                     | 1,2                                   |
| BAYSENS074*                  | Override Sensor with Setpoint and Override / Cancel | 3                     | 1,2,3                                 |

**BAYSENS016\* Sensor with plug;  
Thermistor Sensor (OAT, SAS, RAT, CTS)**

**Outdoor Air Sensor** - Located in the condenser section, lower left corner. The compressor access panel has a slotted opening to provide airflow across the sensor. Standard with all ReliaTel™ controlled units.

**Return Air Sensor** - Field or factory installed accessory. Located on the return air damper of the economizer, used with comparative enthalpy control only.

**Coil Temperature Sensor** - Located in a 3/8 inch copper tube well, which is brazed to the lowest circuit entering the outdoor coil (2 to 10 tons - heat pumps only).

**Mixed Air Sensor** - Field or factory installed in the supply fan section, protruding through the fan housing.

**Discharge Air Sensor** - Field or factory installed in the supply fan section, using an averaging tube located downstream of the heat section.

Figure 57. Thermistor sensor



**BAYSENS106\*/ASYSTAT106\***

Note: Part number - SENS01515

Accessory heat / cool zone sensor module (ZSM) single setpoint, manual changeover. Four conductors required.

Figure 58. BAYSENS106\*/ASYSTAT106\*

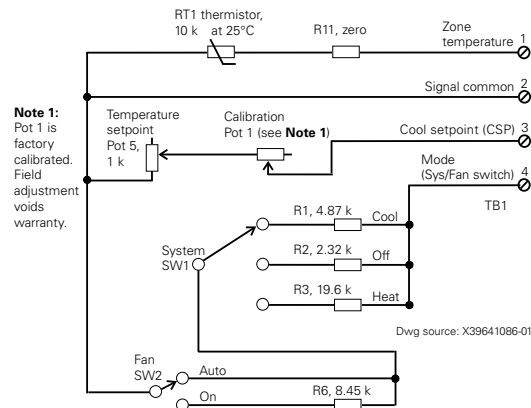

### BAYSENS107\*/ASYSTAT107\*

**Note:** Part number - SEN01528

Accessory heat pump zone sensor module (ZSM) single set point, manual changeover. Six conductors required.

**Figure 59. BAYSENS107\*/ASYSTAT107\***

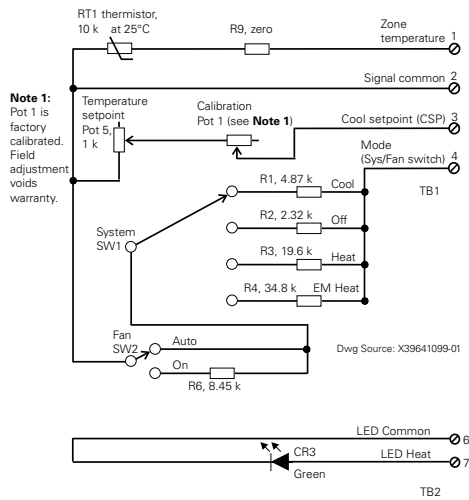

### BAYSENS108\*/ASYSTAT108\*

**Note:** Part number - SEN01513

Accessory heat / cool zone sensor module (ZSM) dual set point, manual / auto changeover. Five conductors required.

**Figure 60. BAYSENS108\*/ASYSTAT108\***

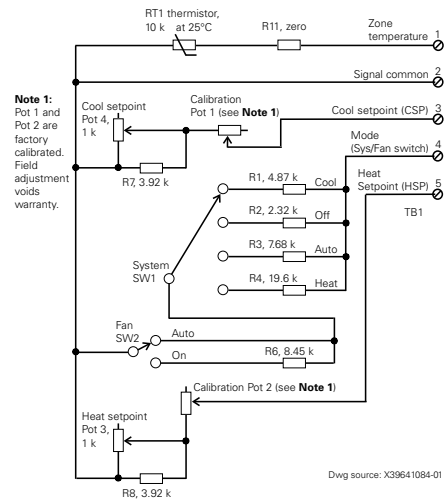

**BAYSENS109\*/ASYSTAT109\***

**Note:** Part number - SEN01523

Accessory heat pump zone sensor module (ZSM) dual set point with LEDs, manual / auto changeover. Ten conductors required.

**Figure 61. BAYSENS109\*/ASYSTAT109\***

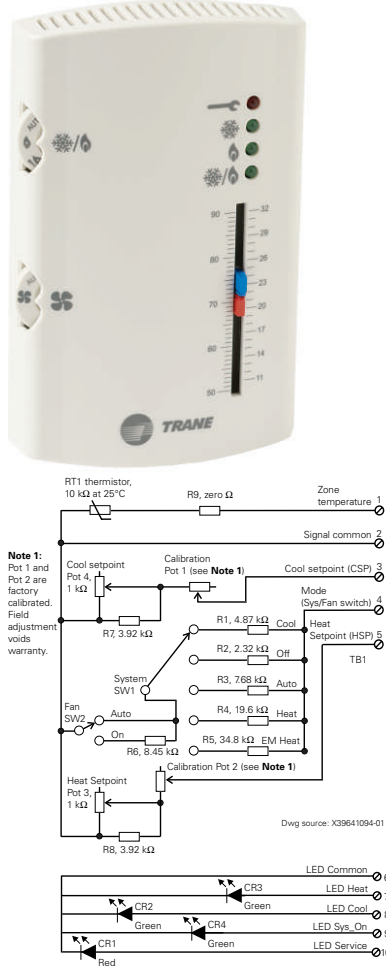

**BAYSENS110\***

**Note:** Part number - SEN01522

Accessory heat / cool zone sensor module (ZSM) dual set point with LEDs, manual / auto changeover. Ten conductors required.

**Figure 62. BAYSENS110\*/ASYSTAT110\***

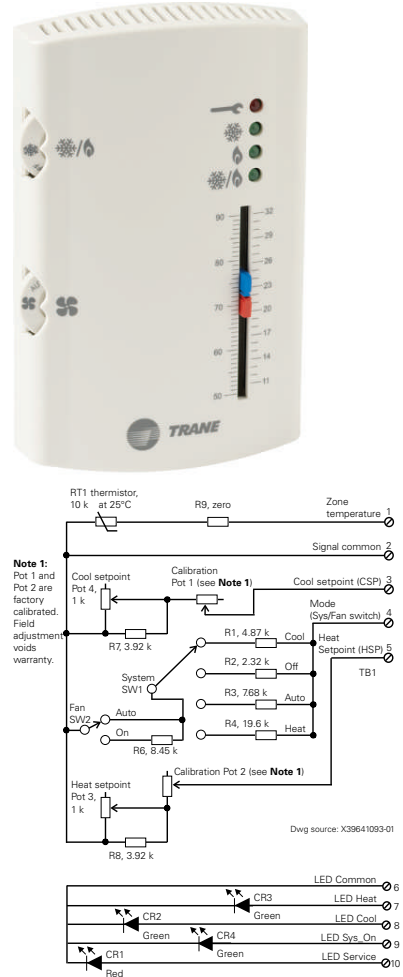

### BAYSENS077\*

**Note:** Part number - SEN01448

Accessory zone sensor remote, used with all current zone sensors. Two conductors required.

**Figure 63. BAYSENS077\***

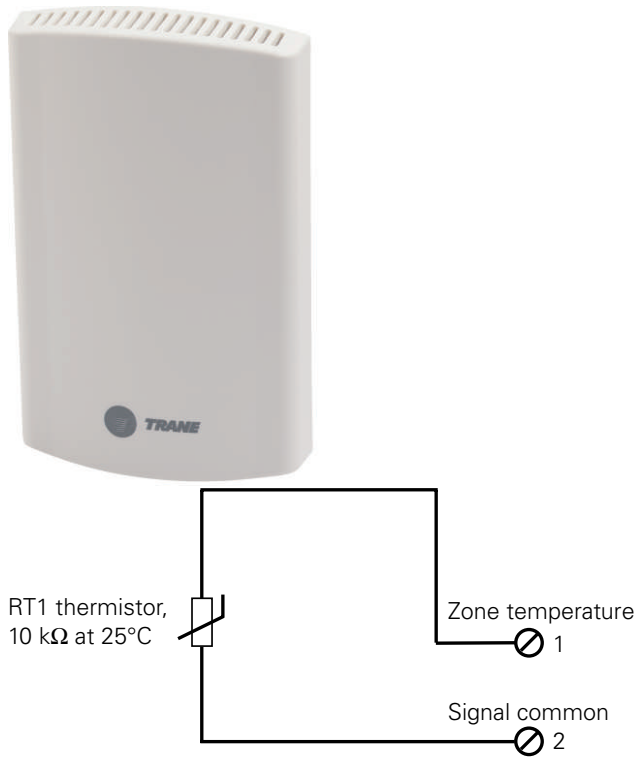

Dwg source: 3270 3436

### BAYSENS073\*

**Note:** Part number - SEN01450

Accessory ICS (Tracker®/Tracer®) zone sensor module (ZSM), with override button, and override cancel button. Two conductors required.

**Figure 64. BAYSENS073\***

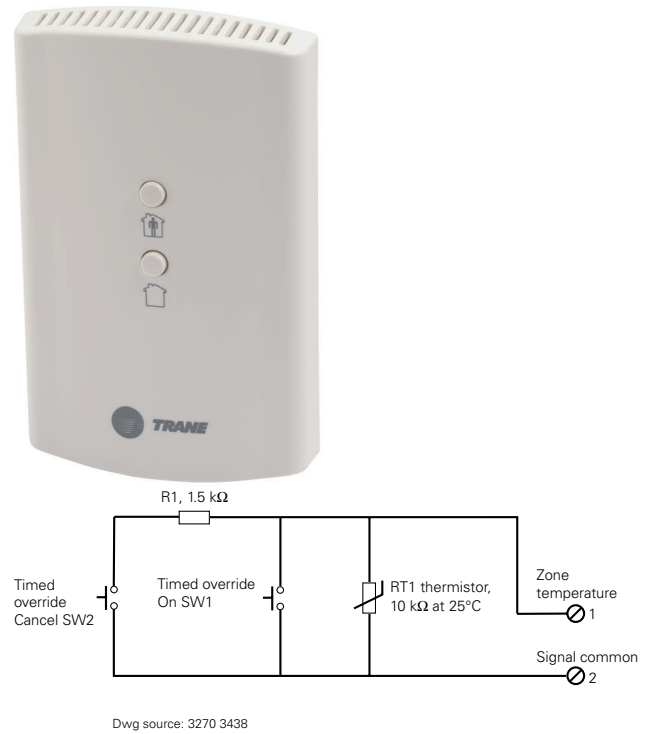

Dwg source: 3270 3438

**BAYSENS074\***

*Note: Part number - SEN01447*

Accessory ICS (Tracker®/Tracer®) zone sensor module (ZSM), with override button, set point, and override cancel button. Three conductors required.

**Figure 65. BAYSENS074\***

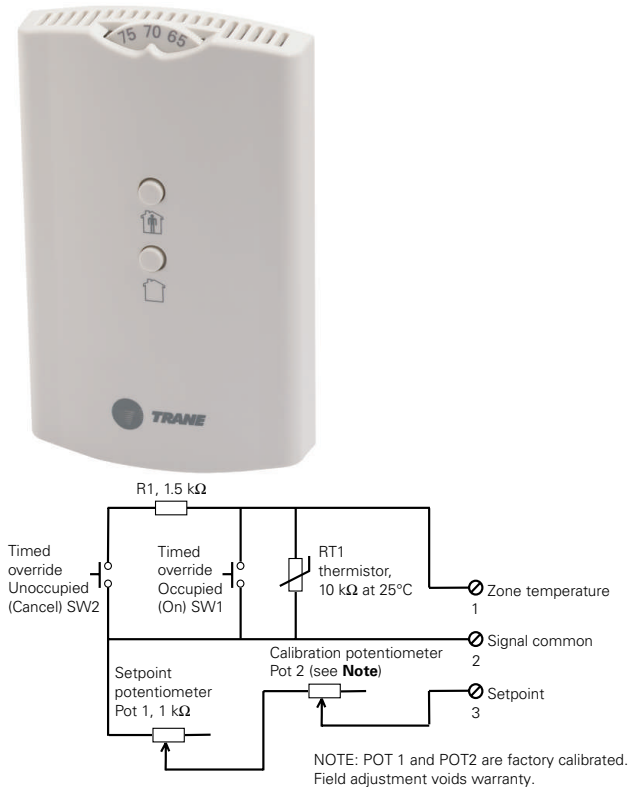

Dwg. source: 3270 3435 B

**BAYSENS119\* Programmable Zone sensor**

**Figure 66. BAYSENS119\***



The BAYSENS119\* supersedes the BAYSENS019C. The BAYSENS119\* has the same programming options and capabilities as the BAYSENS019C but also has improved thermistors that increases sensing accuracy and is still compatible with all equipment using either UCP or ReliaTel™ microcontrols. The BAYSENS119\* can be used with VAV, constant volume, or heat pump equipment.

**Figure 67. Display with all the symbols showing**

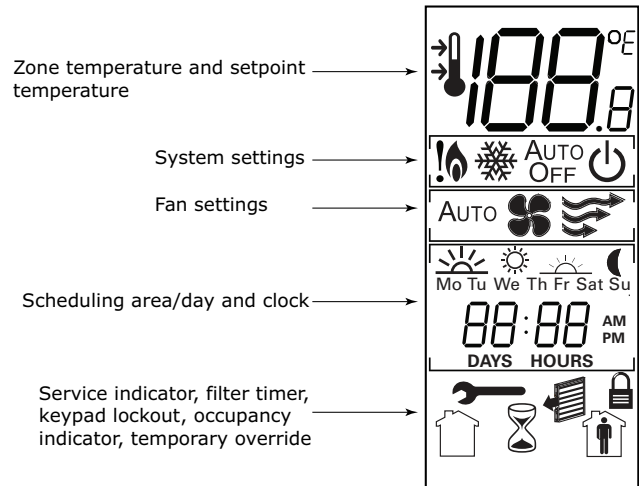

**Table 75. BAYSENS119\* ReliaTel™ wiring locations**

| Sensor                             |    | 3 to 25 ton packaged rooftops<br>*CD/*CH/*SC/*HC  | 27.5 to 50 ton packaged rooftops<br>YC*/TC*/TE* |
|------------------------------------|----|---|---|
|                                    |    | ReliaTel™ Control J6  | ReliaTel™ Control J6                            |
| Remote Sensor input <sup>(a)</sup> | S2 | Optional remote sensor  |   |
| Remote Sensor Input <sup>(a)</sup> | S1 | Optional remote sensor  |   |
| 24 VAC Input <sup>(b)</sup>        | 14 | 14  | 14  |
| Communications                     | 12 | 12  | 12  |
| Common <sup>(c)</sup>              | 11 | 11  | 11  |
| Service Status (UCM Input)         | 10 | 10  | 10  |
| System Status (On/Off Input)       | 9  | 9   | 9   |
| Cool Status (UCM Input)            | 8  | 8   | 8   |
| Heat Status (UCM Input)            | 7  | 7   | 7   |
| Aux Relay (Closed - Unoccupied)    | A3 | The auxiliary relay on the sensor is form C, rated for 1.25 A at 30 Vac. It is energized during occupied periods. |   |
| Aux Relay (Common)                 | A2 |   |   |
| Aux Relay (Closed - Occupied)      | A1 |   |   |

**Note:** LTB and LTB1 refer to low-voltage terminal boards with numbers 1–20 and two test terminals.

- <sup>(a)</sup> Connect an optional remote sensor (p/n BAYSENS017) to terminals S1 and S2. Connect the shield wire (drain wire) from the shielded cable to terminal 11.
- <sup>(b)</sup> Connect the 24 Vac power supply from the unit controller to terminals 11 and 14.
- <sup>(c)</sup> Data communication between the unit controller and the sensor is accomplished by a serial link connected at terminal 12.

**Table 76. Error codes**

|    |              |  |
|----|--------------|--|
| E1 | Heat failure | Indicates that there is an error in the heating system.            |
| E2 | Cool failure | Indicates that there is an error in the cooling system.            |
| E3 | Test mode    | Indicates that the system is operating in test mode.               |
| E4 | Fan failure  | Indicates that a fan failure has occurred and service is required. |

**Notes:**

1. On the display, error codes toggle with the clock.
2. An error code indicates that technical assistance may be required.

**BAYSENS135\* Non-Programmable Zone Sensor**

Figure 68. BAYSENS135\*

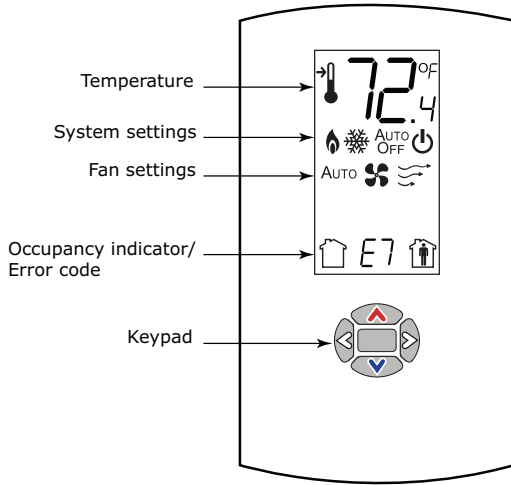

Table 77. BAYSENS135\* ReliaTel™ wiring locations

| Feature Description    | BAYSENS135*       | ReliaTel™ RTRM terminal block (J6) position |
|------------------------|-------------------|---|
| Zone Temperature       | 1                 | 1   |
| 5 Volt Common          | 2                 | 2   |
| Cooling Setpoint       | 3                 | 3   |
| System/Fan Mode        | 4                 | 4   |
| Heating Setpoint       | 5                 | 5   |
| COMM+                  | 6 (not used)      | N/A   |
| COMM-                  | 7 (not used)      | N/A   |
| S1                     | 8 (remote sensor) | N/A   |
| S2                     | 9 (remote sensor) | N/A   |
| Ground (24 VAC Common) | 10                | 11  |
| 24 VAC                 | 11                | 14  |

**Note:** A remote temperature sensor may be used with the BAYSENS135\* but it will not display the remote temperature on the LCD screen.



Figure 69. BAYSENS135\* terminal block

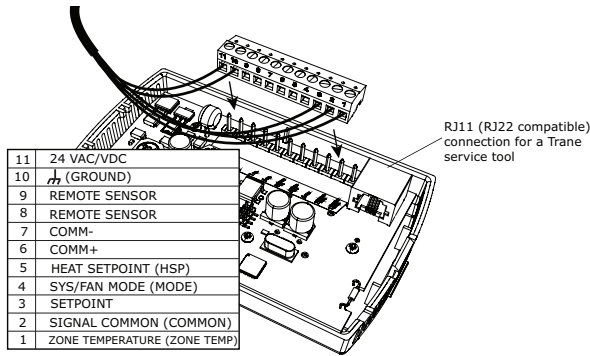



Table 78. Error codes

|    |   |  |
|----|---|--|
| E0 | Main processor error  | Replace sensor   |
| E6 | Software conversion conflict  | Replace sensor   |
| E7 | Communication error   | Replace sensor   |
| E8 | Temperature input outside valid operating range [32°F-122°F (0°C-50°C)] | Replace sensor if space temperature is within valid range. |

Table 79. Lock symbol

|  |                                      |  |
|--|--------------------------------------|--|
|  | Indicates that the keypad is locked. | The lock symbol appears if you try to adjust a setting that cannot be changed. |
|--|--------------------------------------|--|

### BAYSENS924\* Programmable Zone Sensor Wiring

Figure 70. BAYSENS924\*



- extension wire to prevent contact with the metal enclosure and circuit boards.
- Set the link switch on the BCI-R to **BACnet or MSTP**.
- Set BCIR address rotary dials to 0-0-1.

**Important:** Install a jumper wire between terminals J6-1 and 2 when the internal temperature sensor or a sensor wired to terminals 17 and 18 is used.

The BAYSENS924\* zone sensor and the BCI-R form a two node BACnet MS/TP network. Wire the system as shown in the schematic below while adhering to the following recommendations:

- At the RTRM board, terminate the shield wire at J7-COM terminal. The shield wire may need to be extended to make this connection. Use an insulated

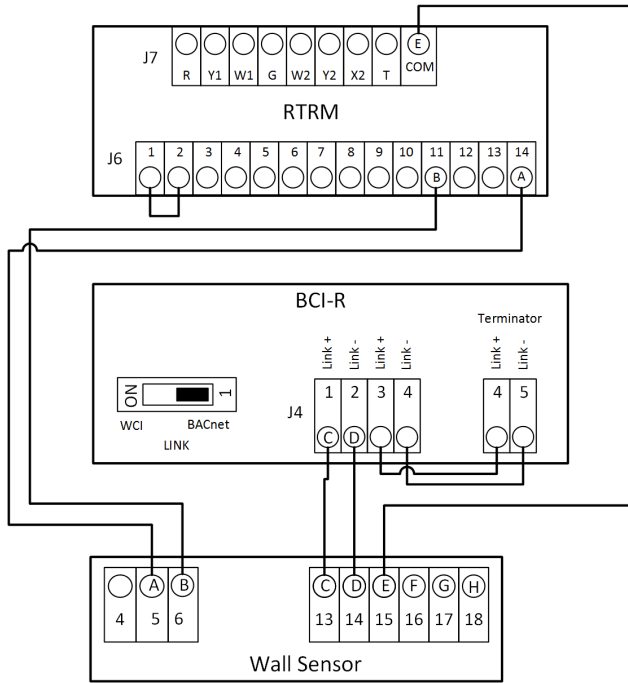

- A: 24 VAC
- B: 24 Vground
- C: BACnet +
- D: BACnet -
- E: Comm. Shield
- F: Demand Shed
- G: Motion Sensor / Thermistor
- H: Input common

## Equipment/Software Supported

The zone sensor controls Precedent™, Voyager™ 2, Voyager 3, and Odyssey™ CV/SZVAV/Multi-speed indoor fan equipment that use the ReliaTel™ control system.

For proper operation, the ReliaTel™ RTRM board must be installed in the equipment and running software version 19.2 or later. In addition, the BCI-R board must be installed and running software version 6.00 or later.

Multi-zone systems are not supported. In the field, multi-zone HVAC equipment can be identified by the presence of the ReliaTel™ RTAM board installed in the equipment.

# Operation with a Conventional Thermostat (Constant Volume)

The ReliaTel™ module has conventional thermostat connections as well as zone sensor module connections. When a conventional thermostat is controlling the unit, operation differs as follows.

- Supply air tempering feature is not available. If outdoor air is being introduced through the equipment, discharge air temperature may be cold when not actively heating.
- Proportional integral (PI) control is not available.
- Zone sensor diagnostics are only available on the RTRM module on the J6 terminals, instead of at the zone sensor in the space.
- Intelligent fall-back is not available. If a failure occurs in the device controlling the equipment, operation will cease.
- Heat pump smart recovery and smart staging is not available. Heat pump operation becomes more costly unless the generic control being applied can accomplish this.
- Remote sensing capabilities are not available on most mechanical thermostats.
- Space temperature averaging capabilities are not available on most mechanical thermostats.
- Built in night set back and unoccupied functions function differently with a conventional mechanical thermostat.
- A built-in algorithm which allows for automatic reset of the discharge air temperature while economizing is not available.

**Note:** MZVAV units - conventional thermostat input terminals are inactive.

**Figure 71. RTRM - J7**

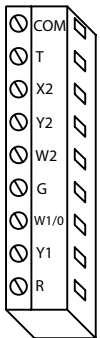

The terminal strip for attaching the thermostat wires is located on the RTRM module in the control compartment. The purpose of each terminal is discussed in the next section. Customers occasionally require operation with a conventional thermostat rather than a zone sensor. In some cases there is a preference for a specific thermostat

model, and in others there is reluctance to adopt newer technology that may not be as well understood as conventional thermostats.

In addition, non-Trane® building controllers typically provide an interface to HVAC equipment based on a conventional thermostat interface. Units applied with this type of controller need to accept conventional thermostat inputs.

Conventional thermostat signals represent direct calls for unit functions. In their simplest applications, thermostat contacts directly control contactors or other load switching devices. This function provides inputs for the thermostat signals and processing to enhance reliability and performance. Compressor protection and reliability enhancement functions (HPC, LPC, minimum on/off timers, etc.) all operate the same whether applied with zone sensors or a conventional thermostat.

Logic is also provided to cause appropriate unit functions when inappropriate thermostat signals are provided.

Simultaneous calls for heating and cooling will be ignored (the unit will not heat or cool). The supply fan will be turned on with a call for heating or cooling even if the fan request is not detected.

If the thermostat is immediately changed from a heating to a cooling call, or vice versa, there will be a five minute delay before the new call will initiate. For units with modulating gas heat, see [Figure 72, p. 121](#) for a flow chart outlining operation with a conventional thermostat.

**Note:** Single Zone VAV units will not work properly with a 24 volt thermostat. Use of a 24 volt thermostat with a SZVAV unit is not recommended.

**Table 80. Thermostat signals**

|                       |  |
|-----------------------|--|
| R                     | 24 VAC power to thermostat   |
| Y1                    | Call for compressor 1 or first stage cooling                                       |
| Y2                    | Call for compressor 2 or 2nd stage cooling   |
| G                     | Call for supply fan  |
| W1                    | Call for heat 1 (for modulating gas, see <a href="#">Figure 72, p. 121</a> )       |
| W2                    | Call for heat  |
| <b>Heat pump only</b> |  |
| X2                    | Call for emergency heat  |
| O                     | Switchover valve On = cooling, Off = heating                                       |
| T                     | Bias for heat anticipation for those mechanical thermostats that use this function |

## Operation with a Conventional Thermostat (Constant Volume)

**Table 81. Conventional thermostat – gas/electric, electric heat**

| Input/connection                                    | Function when energized   |
|---|---|
| G (fan)   | Fan runs continuously except during unoccupied mode (see next page) |
| Y1 (compressor 1 or economizer)                     | Compressor #1 runs or economizer operates                           |
| Y2 (compressor 2 or compressor 1 while economizing) | Compressor #2 also runs, or #1 compressor runs while economizing    |
| W1 (gas / electric heat first stage)                | 1st stage heat  |
| W2 (gas / electric heat 2nd stage)                  | 2nd stage heat (if available)                                       |

**Table 82. Conventional thermostat – heat pump**

| Input/connection                                    | Function when energized   |
|---|---|
| <b>Cooling mode:</b>                                |   |
| G (fan)   | Fan runs continuously except during unoccupied mode (see next page) |
| O (reversing valve during cooling)                  | Reversing valve in cool mode  |
| Y1 + O (first stage cooling)                        | Compressor #1 runs or economizer operates                           |
| Y1 + Y2 + O (2nd stage cool)                        | Compressor #2 also runs, or #1 compressor runs while economizing.   |
| <b>Heating mode:</b>                                |   |
| G (fan)   | Fan runs continuously except during unoccupied mode (see below)     |
| Y1 (both compressors 1st stage heat) <sup>(a)</sup> | Both compressors run  |
| Y2 (during heating – nothing happens)               | No change   |
| W2 (electric heat 2nd stage)                        | 2nd stage (electric) heat   |
| X2 (electric heat only)                             | Electric heat only – no compressors                                 |

<sup>(a)</sup> For units configured with 2-step mechanical heating (Odyssey™ Independent Circuit Heat Pump), Y1 will correspond to a request for compressor 1 operation and Y2 will correspond to a request for compressor 2 operation.

**T:** provides heat anticipation signal for those mechanical thermostats that use this feature. If the thermostat used does not have a “T” terminal, disregard this terminal.

**Unoccupied mode:** If the thermostat being used is programmable, it will have its own strategy for unoccupied mode and will control the unit directly. If a mechanical thermostat is being used, a field applied time clock with relay contacts connected to J6-11 and J6-12 can initiate an unoccupied mode as follows:

- **Contacts open:** Normal occupied operation.

- **Contacts closed:** Unoccupied operation as follows - Fan in auto mode regardless of fan switch position. Economizer closes except while economizing regardless of minimum position setting.

## Cooling/Economizer Operation

If unit does not have an economizer, the Cool/Econ will call directly for mechanical cooling (compressor) stages. If the unit has an economizer, the Cool/Econ stages will function as follows:

**Table 83. Cooling/economizer operation with thermostat**

| OK to Economize | Thermostat Y1 | Call for Thermostat Y2 | Economizer Cooling | Compressor Staging Request |
|-----------------|---------------|------------------------|--------------------|----------------------------|
| No              | On            | Off                    | Inactive           | Compressor Output 1        |
| No              | Off           | On                     | Inactive           | Compressor Output 2        |
| No              | On            | On                     | Inactive           | Compressor Outputs 1 and 2 |
| Yes             | On            | Off                    | Active             | Off                        |
| Yes             | Off           | On                     | Active             | Off                        |
| Yes             | On            | On                     | Active             | Compressor Output 1        |

Notes:

1. Y1 = 1st stage, Y1 + Y2 = 2nd stage
2. Thermostat inputs are ignored on VAV units.

**Table 84. Cooling / Economizer operation Voyager commercial - 27.5 to 50 tons**

| OK to Economizer | Thermostat Y1 | Thermostat Y2 | Economizer Cooling | Compressor Staging Request (Std Eff)                          | Compressor Staging Request (Hi Eff) |
|------------------|---------------|---------------|--------------------|---|-------------------------------------|
| No               | On            | Off           | Inactive           | Compressor Output 1   | Compressor Output 1                 |
| No               | Off           | On            | Inactive           | Compressor Output 2 (3 stage thermostat - 40 and 50 ton Only) | Compressor Output 1 and 2           |
| No               | On            | On            | Inactive           | Compressor Output 1 and 2                                     | Compressor Output 1, 2 and 3        |
| Yes              | On            | Off           | Active             | Off   | Off                                 |
| Yes              | Off           | On            | Active             | Off   | Off                                 |
| Yes              | On            | On            | Active             | Compressor Output 1   | Compressor Output 1 and 2           |

Figure 72. Modulating gas heat control process — thermostat control

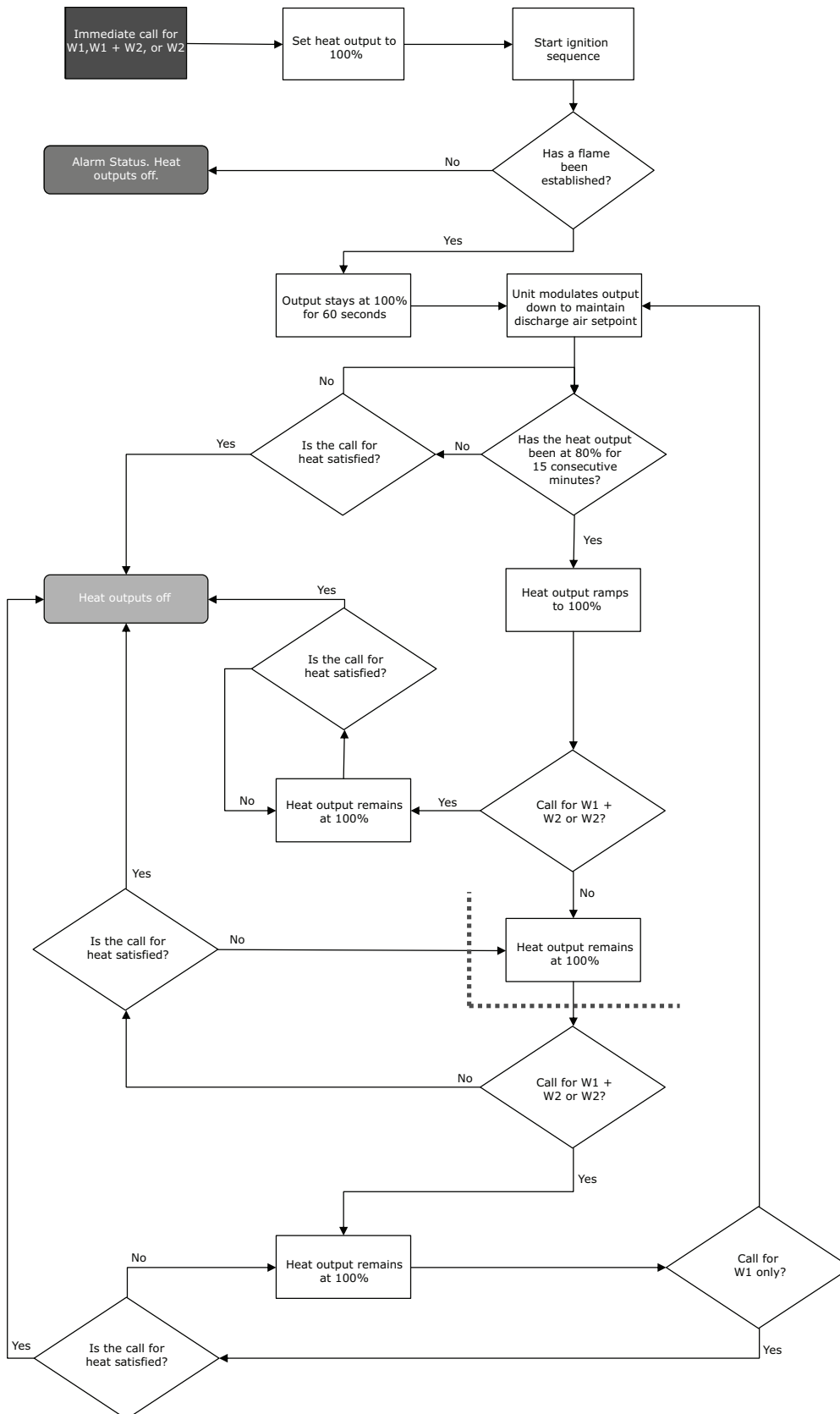

## Voyager 25 Tons 4 Stage Cooling

### ZSM Control of 4 Stage Cooling

Table 85. 25 ton 4 stage lead

|                                | Cmpr 1 | Cmpr 2 | Cmpr 3 | Unit Load% |
|--------------------------------|--------|--------|--------|------------|
| <b>Compressor Displacement</b> | 25.0%  | 25.0%  | 50.0%  |            |
| <b>Stage 1</b>                 | ON     | OFF    | OFF    | 25%        |
| <b>Stage 2</b>                 | ON     | ON     | OFF    | 50%        |
| <b>Stage 3</b>                 | ON     | OFF    | ON     | 75%        |
| <b>Stage 4</b>                 | ON     | ON     | ON     | 100%       |

Table 86. 25 ton 4 stage lag

|                                | Cmpr 1 | Cmpr 2 | Cmpr 3 | Unit Load% |
|--------------------------------|--------|--------|--------|------------|
| <b>Compressor Displacement</b> | 25.0%  | 25.0%  | 50.0%  |            |
| <b>Stage 1</b>                 | OFF    | ON     | OFF    | 25%        |
| <b>Stage 2</b>                 | ON     | ON     | OFF    | 50%        |
| <b>Stage 3</b>                 | OFF    | ON     | ON     | 75%        |
| <b>Stage 4</b>                 | ON     | ON     | ON     | 100%       |

### Conventional Thermostat Control

Table 87. 25 ton 4 stage no economizer or economizer (not enthalpy enabled)

| Tstat Call   | Econ | Cmpr 1 | Cmpr 2 | Cmpr 3 | Unit Load% |
|--------------|------|--------|--------|--------|------------|
|              |      | 25.0%  | 25.0%  | 50.0%  |            |
| <b>Y1</b>    | NA   | ON     | ON     | OFF    | 25%        |
| <b>Y2</b>    | NA   | ON     | ON     | OFF    | 50%        |
| <b>Y1+Y2</b> | NA   | ON     | ON     | ON     | 100%       |

Table 88. 25 ton 4 stage economizer (if enthalpy enabled)

| Tstat Call   | Econ             | Cmpr 1 | Cmpr 2 | Cmpr 3 | Unit Load% |
|--------------|------------------|--------|--------|--------|------------|
|              |                  | 25.0%  | 25.0%  | 50.0%  |            |
| <b>Y1</b>    | <b>OPEN</b>      | OFF    | OFF    | OFF    | 0%         |
| <b>Y2</b>    | <b>OPEN</b>      | OFF    | OFF    | OFF    | 0%         |
| <b>Y1+Y2</b> | <b>OPEN 100%</b> | ON     | ON     | OFF    | 50%        |

Only use for TSTAT control without economizer or with economizer not enabled:

If 2 stage Tstat: Y1 = Comp 1;

Y1+Y2 = Comp 1, 2, and 3

If 3 stage Tstat: Y1 = Comp 1;

Y2 = Comp 1 and 2;

Y2+Y2 = Comp 1, 2 and 3

Only use for TSTAT control with economizer enabled:

If 2 stage Tstat: Y1 = Econ;

Y1+Y2 = Stage 3

If 3 stage Tstat: Y1 = Econ;

Y2 = Econ;

Y1+Y2 = Stage 3

# Zone Sensor Module Testing

## Mechanical Zone Sensor Module

### Temperature Input

#### Terminals to Read Voltage: RTRM J6-1, J6-2

Read DC voltage with the sensor attached. If voltage does not appear to be correct, read the resistance of the circuit, then the sensor itself, to see if a problem exists in the sensor or the wiring. With the sensor not attached there should be 5.00 Vdc at the terminals as shown below.

#### Problems to Look for:

- Mis-wire/short/open
- Excessive resistance in circuit (corroded or loose connection)
- Sensor inaccurate (should be  $\pm 2^{\circ}\text{F}$  of chart)
- Moisture in sensor (becomes accurate when dry)
- Induced voltage (high voltage wires in same conduit)

#### Service Tips

To check for induced voltage, read AC voltage to ground from each sensor wire. Should be less than 1 Vac.

**Figure 73. Temperature input / voltmeter display**

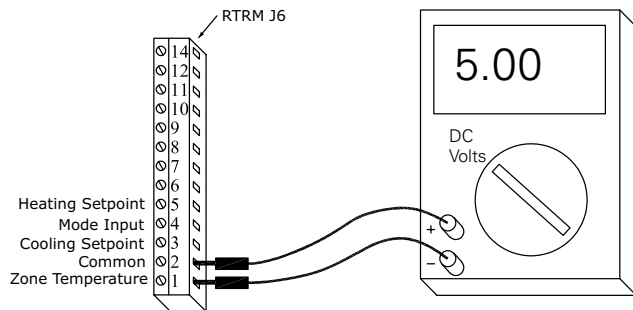

**Table 89. Temperature input**

| Temp °F | Resistance (K ohms) | DC Volts |
|---------|---------------------|----------|
| 40      | 26.097              | 3.613    |
| 41      | 25.383              | 3.585    |
| 42      | 24.69               | 3.557    |
| 43      | 24.018              | 3.528    |
| 44      | 23.367              | 3.5      |
| 45      | 22.736              | 3.471    |
| 46      | 22.123              | 3.442    |
| 47      | 21.53               | 3.412    |
| 48      | 20.953              | 3.383    |
| 49      | 20.396              | 3.353    |
| 50      | 19.854              | 3.324    |
| 51      | 19.33               | 3.294    |
| 52      | 18.821              | 3.264    |
| 53      | 18.327              | 3.233    |
| 54      | 17.847              | 3.203    |
| 55      | 17.382              | 3.173    |
| 56      | 16.93               | 3.142    |
| 57      | 16.491              | 3.111    |
| 58      | 16.066              | 3.08     |
| 59      | 15.654              | 3.05     |
| 60      | 15.253              | 3.019    |
| 61      | 14.864              | 2.988    |
| 62      | 14.486              | 2.957    |
| 63      | 14.119              | 2.926    |
| 64      | 13.762              | 2.895    |
| 65      | 13.416              | 2.864    |
| 66      | 13.078              | 2.832    |
| 67      | 12.752              | 2.801    |
| 68      | 12.435              | 2.77     |
| 69      | 12.126              | 2.739    |
| 70      | 11.827              | 2.708    |
| 71      | 11.535              | 2.677    |
| 72      | 11.252              | 2.646    |
| 73      | 10.977              | 2.616    |
| 74      | 10.709              | 2.58     |
| 75      | 10.448              | 2.554    |
| 76      | 10.194              | 2.523    |
| 77      | 9.949               | 2.493    |
| 78      | 9.71                | 2.462    |
| 79      | 9.477               | 2.432    |
| 80      | 9.25                | 2.402    |
| 81      | 9.03                | 2.372    |
| 82      | 8.815               | 2.342    |
| 83      | 8.607               | 2.312    |
| 84      | 8.404               | 2.283    |
| 85      | 8.206               | 2.253    |
| 86      | 8.014               | 2.224    |
| 87      | 7.827               | 2.195    |
| 88      | 7.645               | 2.166    |
| 89      | 7.468               | 2.137    |
| 90      | 7.295               | 2.109    |
| 91      | 7.127               | 2.08     |
| 92      | 6.963               | 2.052    |
| 93      | 6.803               | 2.024    |
| 94      | 6.648               | 1.996    |
| 95      | 6.497               | 1.969    |

### Setpoint Input

#### Terminals to Read Voltage: RTRM J6-3 (cooling), J6-5 (heating), J6-2

Read DC voltage with zone sensor module (ZSM) attached. If voltage read does not appear to be correct, read the resistance of the circuit, then the ZSM itself, to see if a problem exists in the ZSM or the wiring. With the ZSM not attached there should be 5.00 Vdc at the terminals as shown. To check for induced voltage, read AC voltage to ground from each sensor wire. Should be less than 2 Vac.

Figure 74. Setpoint input / voltmeter display

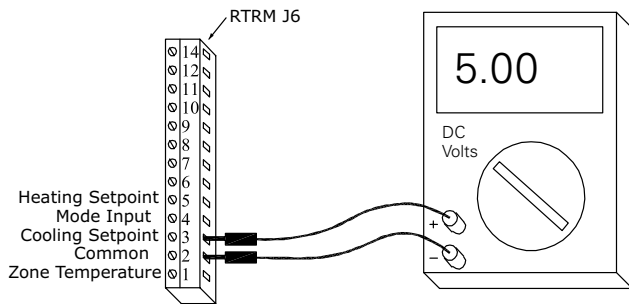

Table 90. Setpoint input

| Setpoint Inputs  | Read voltage at either location |                |
|------------------|---------------------------------|----------------|
| Cooling setpoint | RTRM J6-3                       | ZSM terminal 3 |
| Heating setpoint | RTRM J6-5                       | ZSM terminal 5 |
| Common           | RTRM J6-2                       | ZSM terminal 2 |

#### Problems to Look for:

- Miswire/short/open
- Excessive resistance in circuit (corroded or loose connection)
- Setpoint lever inaccurate (should be +-2F of chart)
- Induced voltage (high voltage wires in same conduit)

Table 91. Setpoint inputs

| Temp °F | Resistance (K ohms) | DC Volts            |
|---------|---------------------|---------------------|
|         | open                | 5.00 (open circuit) |
| 40      | 1.0841              | 2.601               |
| 41      | 1.0656              | 2.579               |
| 42      | 1.0472              | 2.557               |
| 43      | 1.0287              | 2.535               |
| 44      | 1.0102              | 2.513               |
| 45      | 0.9918              | 2.49                |
| 46      | 0.9733              | 2.466               |
| 47      | 0.9548              | 2.442               |
| 48      | 0.9363              | 2.418               |
| 49      | 0.9179              | 2.393               |
| 50      | 0.8994              | 2.368               |
| 51      | 0.8787              | 2.338               |
| 52      | 0.858               | 2.309               |
| 53      | 0.8373              | 2.278               |
| 54      | 0.8166              | 2.247               |
| 55      | 0.7958              | 2.216               |

Table 91. Setpoint inputs (continued)

| Temp °F            | Resistance (K ohms) | DC Volts |
|--------------------|---------------------|----------|
| 56                 | 0.7751              | 2.183    |
| 57                 | 0.7544              | 2.15     |
| 58                 | 0.7337              | 2.116    |
| 59                 | 0.7142              | 2.083    |
| 60                 | 0.6948              | 2.05     |
| 61                 | 0.6753              | 2.015    |
| 62                 | 0.6558              | 1.98     |
| 63                 | 0.6363              | 1.944    |
| 64                 | 0.6169              | 1.908    |
| 65                 | 0.5974              | 1.87     |
| 66                 | 0.5779              | 1.831    |
| 67                 | 0.5584              | 1.792    |
| 68                 | 0.539               | 1.751    |
| 69                 | 0.5195              | 1.709    |
| 70                 | 0.5                 | 1.667    |
| 71                 | 0.4805              | 1.623    |
| 72                 | 0.461               | 1.578    |
| 73                 | 0.4416              | 1.532    |
| 74                 | 0.4221              | 1.484    |
| 75                 | 0.4026              | 1.435    |
| 76                 | 0.3832              | 1.385    |
| 77                 | 0.3637              | 1.333    |
| 78                 | 0.3442              | 1.28     |
| 79                 | 0.3247              | 1.226    |
| 80                 | 0.3053              | 1.169    |
| 81                 | 0.2858              | 1.111    |
| 82                 | 0.2663              | 1.051    |
| 83                 | 0.2468              | 0.99     |
| 84                 | 0.2273              | 0.926    |
| 85                 | 0.2079              | 0.86     |
| 86                 | 0.1884              | 0.793    |
| 87                 | 0.1689              | 0.723    |
| 88                 | 0.1495              | 0.65     |
| 89                 | 0.1301              | 0.575    |
| 90                 | 0.1106              | 0.498    |
| (shorted/no power) |                     | 0        |

### Mode Input

#### Terminals to Read Voltage: RTRM J6-4, J6-2

Read DC voltage with zone sensor module (ZSM) attached. If voltage read does not appear to be correct, read the resistance of the circuit, then the ZSM itself, to see if a problem exists in the ZSM or the wiring. With the ZSM not attached there should be 5.00 Vdc at the terminals listed above. To check for induced voltage, read AC voltage to ground from each sensor wire. Should be less than 2 Vac.



Figure 75. Mode input / Voltage reading

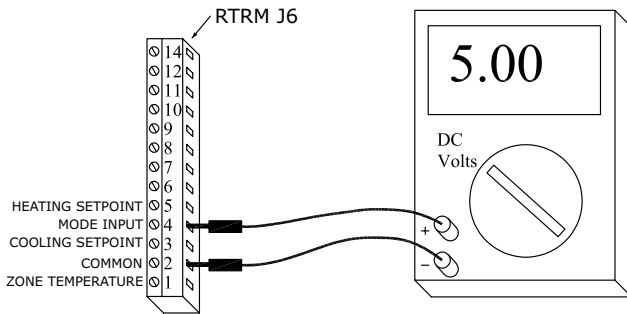

| Mode Input: |           |                |
|-------------|-----------|----------------|
| Mode Input  | RTRM J6-4 | ZSM terminal 4 |
| Common      | RTRM J6-2 | ZSM terminal 2 |

**Problems to Look for:**

- Miswire/short/open
- Excessive resistance in circuit (corroded or loose connection)
- Induced voltage (high voltage wires in same conduit)

Table 92. Zone sensor readings

| System switch   | Fan switch | Ohms Rx1K | Volts DC +- 5% |
|-----------------|------------|-----------|----------------|
| Short to common |            | 0         | 0              |
| OFF             | AUTO       | 2.32      | 0.94           |
| COOL            | AUTO       | 4.87      | 1.64           |
| AUTO            | AUTO       | 7.68      | 2.17           |
| OFF             | ON         | 10.77     | 2.59           |
| COOL            | ON         | 13.32     | 2.85           |
| AUTO            | ON         | 16.13     | 3.08           |
| HEAT            | AUTO       | 19.48     | 3.3            |
| HEAT            | ON         | 27.93     | 3.68           |
| EM HEAT         | AUTO       | 35        | 3.88           |
| EM HEAT         | ON         | 43.45     | 4.06           |
| Open circuit    |            |           | 5              |

**Programmable Zone Sensor BAYSENS119\* and BAYSENS019C (Obsolete)**

The BAYSENS119\* Programmable Zone sensor is a digital display sensor that communicates to micro controls. This programmable sensor is compatible with the following constant volume (CV) units:

- Voyager™ UCP 3 to 25 tons
- Voyager™ UCP 27.5 to 50 tons CV
- Precedent™ ReliaTel™ 3 to 10 tons

- Voyager™ ReliaTel™ 12.5 to 25 tons
- Voyager™ ReliaTel™ 27.5 to 50 tons CV
- IntelliPak™ Rooftop 20 to 130 tons CV
- Odyssey™ ReliaTel™ 6 to 20 tons

For programming information, refer to literature ACC-SVN28\*-EN.

**Testing the Programmable Zone Sensor (PZS)**

1. Verify unit operation by running unit through test mode.
2. Verify that the PZS has a normal display of time, temperature, fan and system status.
3. For UCP Micro, disconnect wires from LTB-11 (-) and LTB-12 (+); For ReliaTel™ controls, disconnect wires from J6-11 and J6-12. Measure the dc voltage between terminals 11 and 12. Voltage should read between 28 to 32 Vdc. If no voltage is present for UCP micro, check wiring between UCP and LTB.
4. Reconnect wires to terminals 11 and 12. Measure the voltage between 11 and 12. Voltage should flash at 0.5 second rate, with a voltage value randomly changing from approximately 24 to 32 Vdc.
5. On the PZS, press the FAN button to turn the fan ON. If the fan comes on, the PZS is good; if the fan does not come on, the PZS may be defective and will need to be replaced.

**Note:** The sensor will not communicate if the wrong baud rate is selected. The PZS is shipped with the baud rate set to 1200. See option menu setup in the literature to verify proper baud rate. The baud rate may need to be changed to 1024 for units built before 1/96.

**Troubleshooting the Programmable Zone Sensor**

Because the PZS is a communicating sensor, troubleshooting is very limited. Step 2 through Step 5 of testing the sensor are the first steps to verify. The following table will provide other troubleshooting tips for diagnosing the sensor and unit operations.

If all wiring and preliminary tests do not indicate any defects, disconnect the PZS from the wall and take to the unit, and with a short (approx. two feet) length of thermostat wire, connect the PZS and see if symptoms still exist. If not, check for thermostat wire routing in close proximity of high voltage wires and fluorescent lights.

## Zone Sensor Module Testing

**Table 93. Troubleshooting**

| Symptom  | Probable Cause and solution  |
|--|--|
| Display does not come on.  | Check for 24 Vac on terminals 11 and 12 of the sensor.   |
| No communication with unit.  | Verify a varying voltage per step 2 of testing the sensor. If no voltage is present, check with wiring to unit.  |
| Sensor is communicating, but unit won't run                                  | Check option 18 in Option Menu setup for correct baud rate.  |
| Displayed zone temperature is different from actual temperature.             | Follow Option Menu setup in literature to calibrate the display.   |
| Zone temperature is not displayed  | Check option selection in Option menu setup  |
| Displayed zone temperature reads "99".                                       | Space temperature is above or below the measurable range of the sensor.  |
| Displayed zone temperature reads "Sh" and the COOL FAIL icon is illuminated. | Verify that option 11 in Option Menu is set correctly. If correct, check the wiring from the remote sensor at terminals S1 and S2 for a shorted condition. |
| Displayed zone temperature reads "oP" and the COOL FAIL icon is illuminated. | Verify that option 11 in Option Menu is set correctly. If correct, check remote sensor wiring at terminals S1 and S2 for an open circuit condition.        |

**Table 93. Troubleshooting (continued)**

| Symptom   | Probable Cause and solution  |
|---|--|
| Programmable sensor will not respond to keypad selections                       | Check lower left corner of display for a padlock icon. If displayed, press and hold the Time (+) and (-) key until the icon goes away.     |
| Fan mode is set to on, but does not run during unoccupied mode. Periods         | Check option 6 in Option menu setup for Auto selection during unoccupied.  |
| Buzzer indicates System Failure, Check filter or service is required.           | Press erase key to reset filter lapse timer. Buzzer will be reset until noon of the next day if a system failure has not been corrected.   |
| sensor will not hold override changes.  | Press the HOLDTEMP button within 20 seconds after changes are made.  |
| COOL FAIL flashes and unit doesn't run. Check for varying voltage on terminals. | Sensor not communicating with unit. 11 and 12 at the unit. If voltage is steady at approximately 30 Vdc, check for open circuit in wiring. |
| COOL FAIL + HEAT FAIL icons flash simultaneously                                | Check for defective outside air sensor. Emergency input is open. (RTRM version 4.0) Coil Temp Sensor fail (HP).                            |
| HEAT FAIL flashing  | A heat failure has occurred. If HP unit, the unit may be in emergency heat, or there is a defrost problem.                                 |

# RTRM/RTOM/RTDM - Temperature Inputs

## Outdoor Air Sensor, Discharge Air Sensor, Coil Temperature Sensor, Entering Evaporator Temperature Sensor

### Terminals to Read Voltage

Outdoor Air Sensor — RTRM J8-2, J8-1

Discharge Air Sensor — RTOM J4-5, J4-4

Coil Temperature Sensor 1 — RTRM J2-3, J2-4

Coil Temperature Sensor 2 — RTRM J9-2, J9-1

Entering Evaporator Temperature Sensor - RTDM J6-2, J6-3

**Note:** These are RTRM, RTOM inputs only. Economizer inputs (MAT, OAH, RAT, RAH, CO<sub>2</sub>) are in the ReliaTel™ economizer inputs section.

Read DC voltage with the sensor attached. If voltage does not appear to be correct, read the resistance of the circuit, then the sensor itself, to see if a problem exists in the sensor or the wiring. With the sensor not attached there should be 5.00 Vdc at the terminals listed above.

### Service Tips

The second sensor terminal listed above is common. All common terminals are one volt meter lead can be attached to ground for voltage tests. To check for induced voltage, read AC voltage to ground from each sensor wire. This be less than 1 Vac.

### Problems to Look for

- Miswire / short / open
- Excessive resistance in circuit (corroded or loose connection)
- Sensor inaccurate (should be +/- 2°F of chart)
- Moisture in sensor (becomes accurate when dry)
- Induced voltage (high voltage wires in same conduit)

**Table 94. Temperature input**

| Temp °F | Resistance (K ohms) | DC Volts |
|---------|---------------------|----------|
| -40     | 345.684             | 4.856    |
| -39     | 333.237             | 4.851    |
| -38     | 321.274             | 4.845    |
| -37     | 309.777             | 4.84     |
| -36     | 298.724             | 4.834    |
| -35     | 288.097             | 4.828    |
| -34     | 277.879             | 4.823    |
| -33     | 268.053             | 4.816    |
| -32     | 258.603             | 4.81     |
| -31     | 249.523             | 4.804    |
| -30     | 240.81              | 4.797    |
| -29     | 232.425             | 4.79     |
| -28     | 224.355             | 4.783    |

**Table 94. Temperature input (continued)**

| Temp °F | Resistance (K ohms) | DC Volts |
|---------|---------------------|----------|
| -27     | 216.59              | 4.776    |
| -26     | 209.114             | 4.768    |
| -25     | 201.918             | 4.76     |
| -24     | 194.991             | 4.752    |
| -23     | 188.32              | 4.744    |
| -22     | 181.904             | 4.736    |
| -21     | 175.738             | 4.727    |
| -20     | 169.798             | 4.718    |
| -19     | 164.076             | 4.709    |
| -18     | 158.562             | 4.7      |
| -17     | 153.248             | 4.69     |
| -16     | 148.127             | 4.68     |
| -15     | 143.192             | 4.67     |
| -14     | 138.435             | 4.66     |
| -12     | 129.449             | 4.638    |
| -11     | 125.199             | 4.627    |
| -10     | 121.1               | 4.615    |
| -9      | 117.146             | 4.603    |
| -8      | 113.331             | 4.591    |
| -7      | 109.652             | 4.579    |
| -6      | 106.102             | 4.566    |
| -5      | 102.676             | 4.553    |
| -4      | 99.377              | 4.54     |
| -3      | 96.197              | 4.526    |
| -2      | 93.127              | 4.512    |
| -1      | 90.163              | 4.498    |
| 0       | 87.301              | 4.483    |
| 1       | 84.537              | 4.468    |
| 2       | 81.868              | 4.453    |
| 3       | 79.291              | 4.437    |
| 4       | 76.802              | 4.421    |
| 5       | 74.403              | 4.404    |
| 6       | 72.087              | 4.388    |
| 7       | 69.849              | 4.371    |
| 8       | 67.687              | 4.353    |
| 9       | 65.597              | 4.336    |
| 10      | 63.577              | 4.317    |
| 11      | 61.624              | 4.299    |
| 12      | 59.737              | 4.28     |
| 13      | 57.913              | 4.261    |
| 14      | 56.153              | 4.241    |
| 15      | 54.452              | 4.221    |
| 16      | 52.807              | 4.201    |
| 17      | 51.216              | 4.18     |
| 18      | 49.677              | 4.159    |
| 19      | 48.188              | 4.138    |
| 20      | 46.748              | 4.116    |
| 21      | 45.354              | 4.094    |
| 22      | 44.007              | 4.072    |
| 23      | 42.705              | 4.049    |
| 24      | 41.446              | 4.026    |
| 25      | 40.226              | 4.002    |
| 26      | 39.046              | 3.978    |
| 27      | 37.904              | 3.954    |
| 28      | 36.797              | 3.929    |
| 29      | 35.726              | 3.904    |
| 30      | 34.689              | 3.879    |
| 31      | 33.686              | 3.853    |
| 32      | 32.72               | 3.827    |

Table 94. Temperature input (continued)

| Temp °F | Resistance (K ohms) | DC Volts |
|---------|---------------------|----------|
| 33      | 31.797              | 3.801    |
| 34      | 30.903              | 3.775    |
| 35      | 30.037              | 3.749    |
| 36      | 29.198              | 3.722    |
| 37      | 28.386              | 3.695    |
| 38      | 27.599              | 3.668    |
| 39      | 26.836              | 3.641    |
| 40      | 26.097              | 3.613    |
| 41      | 25.383              | 3.585    |
| 42      | 24.69               | 3.557    |
| 43      | 24.018              | 3.528    |
| 44      | 23.367              | 3.5      |
| 45      | 22.736              | 3.471    |
| 46      | 22.123              | 3.442    |
| 47      | 21.53               | 3.412    |
| 48      | 20.953              | 3.383    |
| 49      | 20.396              | 3.353    |
| 50      | 19.854              | 3.324    |
| 51      | 19.33               | 3.294    |
| 52      | 18.821              | 3.264    |
| 53      | 18.327              | 3.233    |
| 54      | 17.847              | 3.203    |
| 55      | 17.382              | 3.173    |
| 56      | 16.93               | 3.142    |
| 57      | 16.491              | 3.111    |
| 58      | 16.066              | 3.08     |
| 59      | 15.654              | 3.05     |
| 60      | 15.253              | 3.019    |
| 61      | 14.864              | 2.988    |
| 62      | 14.486              | 2.957    |
| 63      | 14.119              | 2.926    |
| 64      | 13.762              | 2.895    |
| 65      | 13.416              | 2.864    |
| 66      | 13.078              | 2.832    |
| 67      | 12.752              | 2.801    |
| 68      | 12.435              | 2.77     |
| 69      | 12.126              | 2.739    |
| 70      | 11.827              | 2.708    |
| 71      | 11.535              | 2.677    |
| 72      | 11.252              | 2.646    |
| 73      | 10.977              | 2.616    |
| 74      | 10.709              | 2.585    |
| 75      | 10.448              | 2.554    |
| 76      | 10.194              | 2.523    |
| 77      | 9.949               | 2.493    |
| 78      | 9.71                | 2.462    |
| 79      | 9.477               | 2.432    |
| 80      | 9.25                | 2.402    |
| 81      | 9.03                | 2.372    |
| 82      | 8.815               | 2.342    |
| 83      | 8.607               | 2.312    |
| 84      | 8.404               | 2.283    |
| 85      | 8.206               | 2.253    |
| 86      | 8.014               | 2.224    |
| 87      | 7.827               | 2.195    |
| 88      | 7.645               | 2.166    |
| 89      | 7.468               | 2.137    |
| 90      | 7.295               | 2.109    |
| 91      | 7.127               | 2.08     |
| 92      | 6.963               | 2.052    |
| 93      | 6.803               | 2.024    |
| 94      | 6.648               | 1.996    |

Table 94. Temperature input (continued)

| Temp °F | Resistance (K ohms) | DC Volts |
|---------|---------------------|----------|
| 95      | 6.497               | 1.969    |
| 96      | 6.35                | 1.942    |
| 97      | 6.207               | 1.915    |
| 98      | 6.067               | 1.888    |
| 99      | 5.931               | 1.861    |
| 100     | 5.798               | 1.835    |
| 101     | 5.668               | 1.809    |
| 102     | 5.543               | 1.783    |
| 103     | 5.42                | 1.757    |
| 104     | 5.3                 | 1.732    |
| 105     | 5.184               | 1.707    |
| 106     | 5.07                | 1.682    |
| 107     | 4.959               | 1.658    |
| 108     | 4.851               | 1.633    |
| 109     | 4.745               | 1.609    |
| 110     | 4.642               | 1.585    |
| 111     | 4.542               | 1.562    |
| 112     | 4.444               | 1.539    |
| 113     | 4.349               | 1.516    |
| 114     | 4.256               | 1.493    |
| 115     | 4.165               | 1.47     |
| 116     | 4.076               | 1.448    |
| 117     | 3.99                | 1.426    |
| 118     | 3.906               | 1.405    |
| 119     | 3.824               | 1.383    |
| 120     | 3.743               | 1.362    |
| 121     | 3.665               | 1.341    |
| 122     | 3.589               | 1.321    |
| 123     | 3.514               | 1.301    |
| 124     | 3.442               | 1.281    |
| 125     | 3.371               | 1.261    |
| 126     | 3.302               | 1.241    |
| 127     | 3.234               | 1.222    |
| 128     | 3.169               | 1.204    |
| 129     | 3.104               | 1.185    |
| 130     | 3.041               | 1.166    |
| 131     | 2.98                | 1.148    |
| 132     | 2.919               | 1.13     |
| 133     | 2.861               | 1.113    |
| 134     | 2.804               | 1.095    |
| 135     | 2.748               | 1.078    |
| 136     | 2.693               | 1.061    |
| 137     | 2.64                | 1.045    |
| 138     | 2.587               | 1.028    |
| 139     | 2.536               | 1.012    |
| 140     | 2.486               | 0.996    |
| 141     | 2.438               | 0.981    |
| 142     | 2.39                | 0.965    |
| 143     | 2.343               | 0.95     |
| 144     | 2.298               | 0.935    |
| 145     | 2.253               | 0.92     |
| 146     | 2.21                | 0.906    |
| 147     | 2.167               | 0.891    |
| 148     | 2.125               | 0.877    |
| 149     | 2.085               | 0.863    |
| 150     | 2.044               | 0.849    |
| 151     | 2.006               | 0.836    |
| 152     | 1.967               | 0.823    |
| 153     | 1.93                | 0.81     |
| 154     | 1.894               | 0.797    |
| 155     | 1.859               | 0.784    |
| 156     | 1.823               | 0.772    |

Table 94. Temperature input (continued)

| Temp °F | Resistance (K ohms) | DC Volts |
|---------|---------------------|----------|
| 157     | 1.789               | 0.759    |
| 158     | 1.756               | 0.747    |
| 159     | 1.723               | 0.736    |
| 160     | 1.691               | 0.724    |
| 161     | 1.659               | 0.712    |
| 162     | 1.629               | 0.701    |
| 163     | 1.599               | 0.69     |
| 164     | 1.57                | 0.688    |
| 165     | 1.541               | 0.679    |
| 166     | 1.512               | 0.658    |
| 167     | 1.485               | 0.647    |
| 168     | 1.458               | 0.637    |
| 169     | 1.432               | 0.627    |
| 170     | 1.406               | 0.617    |
| 171     | 1.38                | 0.607    |
| 172     | 1.356               | 0.598    |
| 173     | 1.331               | 0.588    |
| 174     | 1.308               | 0.579    |
| 175     | 1.284               | 0.57     |
| 176     | 1.261               | 0.561    |
| 177     | 1.239               | 0.552    |
| 178     | 1.217               | 0.543    |
| 179     | 1.196               | 0.535    |

Table 94. Temperature input (continued)

| Temp °F             | Resistance (K ohms) | DC Volts |
|---------------------|---------------------|----------|
| 180                 | 1.174               | 0.526    |
| 181                 | 1.154               | 0.518    |
| 182                 | 1.133               | 0.51     |
| 183                 | 1.113               | 0.502    |
| 184                 | 1.094               | 0.494    |
| 185                 | 1.076               | 0.487    |
| 186                 | 1.057               | 0.479    |
| 187                 | 1.038               | 0.471    |
| 188                 | 1.02                | 0.464    |
| 189                 | 1.003               | 0.457    |
| 190                 | 0.986               | 0.45     |
| 191                 | 0.969               | 0.443    |
| 192                 | 0.952               | 0.436    |
| 193                 | 0.937               | 0.429    |
| 194                 | 0.92                | 0.422    |
| 195                 | 0.905               | 0.416    |
| 196                 | 0.89                | 0.41     |
| 197                 | 0.875               | 0.403    |
| 198                 | 0.86                | 0.397    |
| 199                 | 0.846               | 0.391    |
| 200                 | 0.831               | 0.385    |
| Shorted or no power |                     | 0        |

# Zone Sensor Averaging

In some applications, one zone sensor does not give a good representation of zone temperature.

The internal thermistors, 10K ohm resistance@25C/77F, can be wired as shown below in order to provide an average input to the mechanical or programmable zone sensor module BAYSENS106\*-BAYSENS111\*/ASYSTAT106-109, ASYSTAT111, BAYSENS019\*/AYSTAT666\*.

If using a Programmable ZSM, the remote sensor wiring must be twisted/shielded. Connect the shield to terminal J6-11. The quantity of sensors in the sensing circuit is extremely important.

The quantity must be a squared number that allows them to be wired in series-parallel configuration. The resistance of

the averaging circuit must duplicate the resistance of a single sensor. The quantities in the averaging circuit will be 4, 9, 16 or etc. A 4 sensor circuit is typical.

**Note:** Operation with 2 or 3 sensors is not possible.

**Figure 76. Zone sensor averaging**

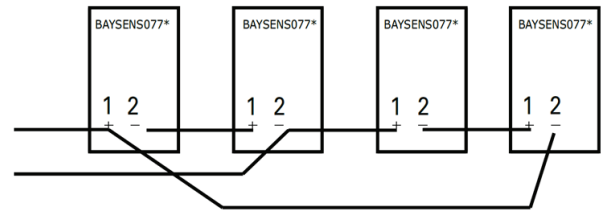

# COMM3/4 Interface

**Note:** COMM3/4 or TCI-R is not compatible with Precedent, Voyager II or Voyager III SZVAV or multi-speed fan applications.

## Operation and Troubleshooting

### Wiring

The COMM3/4 board communicates with the RTRM via the MODBUS link using the harness, labeled 4366-1151. The connections to the board are shown below.

Communication wires must be twisted/shielded as specified by the BAS system being applied. Do not attach the shield to the COMM3/4 board. It must be taped back to prevent it from touching the unit.

### Compatibility

TCI-R or COMM3/4 is not compatible with Precedent, Voyager II or Voyager III SZVAV or Multi-speed supply fan applications.

### LEDs

**Amber receive (RX) LED** - Blinks whenever communication is occurring with any device. This tells the service technician that the BAS system is communicating or trying to communicate with other devices as well as this one.

**Green transmit (TX) LED** - Blinks once every several seconds, sometimes up to 45 seconds between blinks, when the unit is sending data to the BAS system. This tells the service technician that this unit is communicating information to the BAS system. When the TX LED is blinking, the unit is communicating.

### Communication Problems

Figure 77. Troubleshooting outline

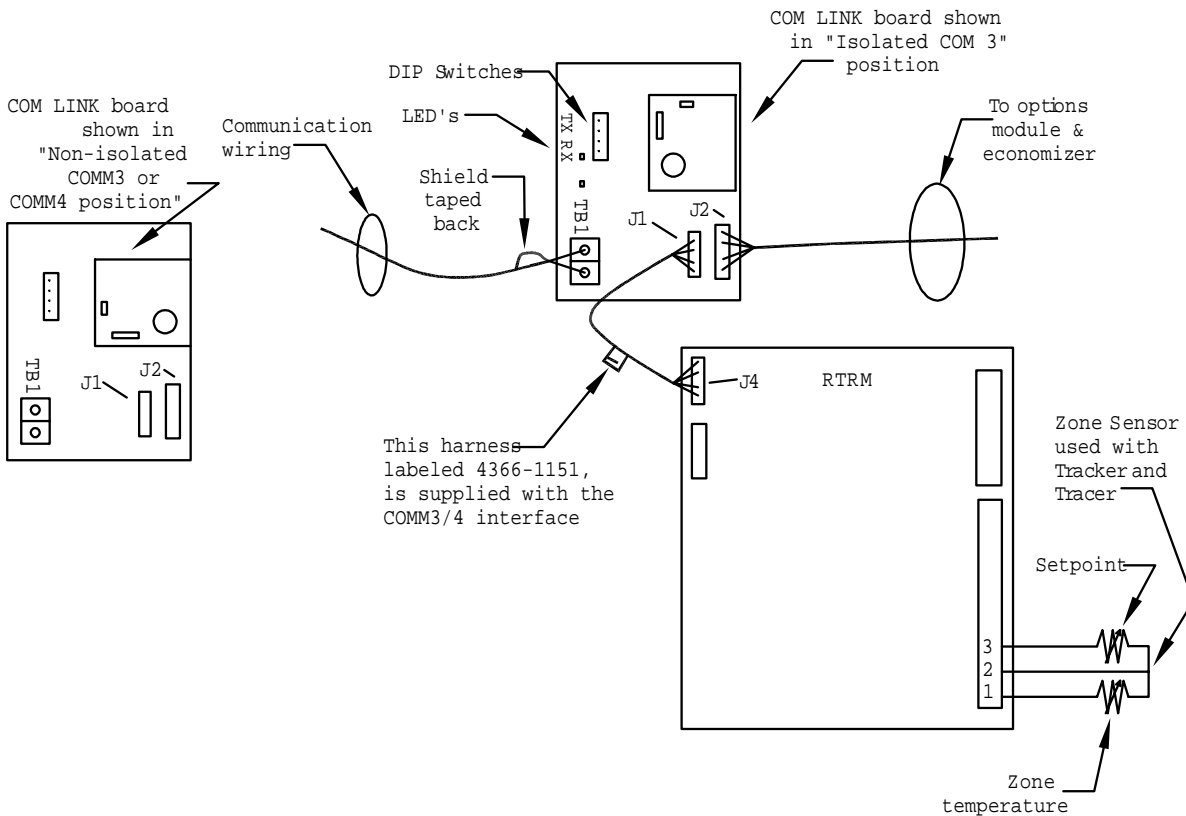

Table 95. Troubleshooting

|  |  |
|--|--|
| <p><b>Won't Communicate with Tracker® - 3 to 25 Tons Only</b></p>  | <p>Harness, labeled 4366-1151, must be plugged into RTRM correctly – see previous page.</p>  |
|  | <p>Com Link board must be in "ISOLATED COM 3" position. If it is in the wrong position or not installed, the unit will not communicate.</p>  |
|  | <p>Each unit must have a unique address by setting the DIP switches according to the IOM. If 2 units have the same address, neither will communicate. If the unit has a DIP switch setting other than the ones specified in the IOM, Tracker® will not recognize it.</p> |
|  | <p>Once the unit communicates with Tracker®, the Tracker® panel will automatically recognize the unit.</p>   |
|  | <p>Resistor missing at last unit in daisy chain (depending on length of line run).</p>   |
| <p><b>Won't Communicate with Tracer® Summit</b></p>  | <p>Harness, labeled 4366-1151, must be plugged into RTRM correctly – see above.</p>  |
|  | <p>Com Link board must be in "NON ISOLATED COMM3 or COMM4" position. If it is in the wrong position or not installed, the unit will not communicate.</p>   |
|  | <p>Each unit must have a unique address by setting the DIP switches according to the IOM. If 2 units have the same address, neither will communicate. If the unit has a DIP switch setting other than the ones specified in the IOM, Tracer® will not recognize it.</p>  |
|  | <p>Once the unit communicates with Tracer®, the Tracer® panel will automatically recognize the unit.</p>   |
| <p><b>Won't Communicate with VariTrac® CCP Zoning System</b></p>   | <p>Harness, labeled 4366-1151, must be plugged into RTRM correctly – see above.</p>  |
|  | <p>Com Link board must be in "NON ISOLATED COMM3 or COMM4" position. If it is in the wrong position or not installed, the unit will not communicate.</p>   |
| <p><b>VariTrac® I Comfort Manager and VariTrac® II Center Control Panel</b></p>                                    | <p>The DIP switches must all be in the ON position. If not, the VariTrac® CCP will not recognize it.</p>   |
|  | <p>The communication wires must be in the same daisy chain link as the dampers.</p>  |
|  | <p>VariTrac® III central control panel (optional touch screen) — All DIP switches must be in the off position. If not, the VariTrac® CCP will not recognize it.</p>  |
| <p><b>Communicates but Will not Run, even in TEST Mode</b></p>   | <p>Emergency stop input is open (RTRM 3J1-12).</p>   |
| <p><b>Communicates but Will not Run; Fan Runs in TEST Mode for 40 Seconds Only (but no Heating or Cooling)</b></p> | <p>3 to 25 tons - Fan proving circuit (RTOM 5J7-6) is closed; should open when fan is on. If not, the fan will run in TEST mode for 40 seconds and then stop.</p>  |
|  | <p>27.5 to 50 tons - Fan proving circuit (RTOM 5J7-6) is opened; should close when fan is on. If not, the fan will run in TEST mode for 40 seconds and then stop.</p>  |



## Unit Addressing

VariTrac I Comfort Manager and VariTrac II Central Control Panel are vertically mounted with an access door. VariTrac III central control panel is horizontally mounted with no access door.

**Figure 78. TCI communications module address setting for Tracker/ComforTrac — address numbers and ReliaTel communications interface board DIP**

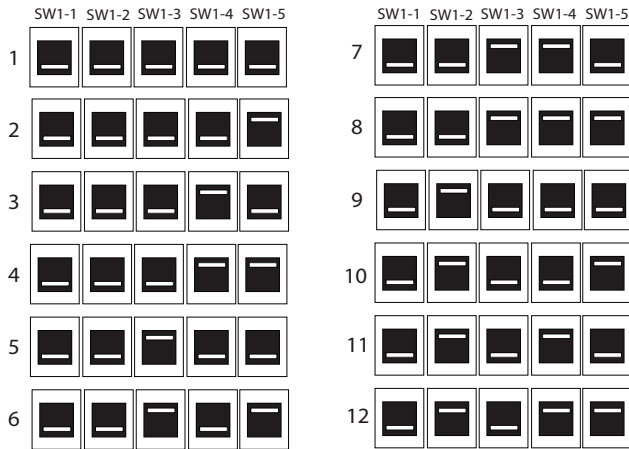

**Figure 79. Comm 3/4 communications module address setting for VariTrac I comfort manager and VariTrac II central control panel— ALL address numbers and ReliaTel communications interface board DIP switch settings**

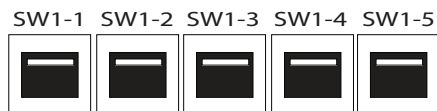

**Figure 80. TCI communications module address setting for VariTrac III central control panel - ALL address numbers and ReliaTel communications interface board DIP switch settings**

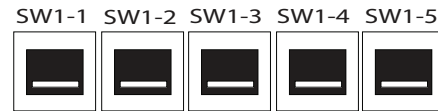

**Figure 81. TCI communications module address setting for Tracer 100 series panels and Tracer Summit — address numbers and ReliaTel communications interface board DIP switch settings**

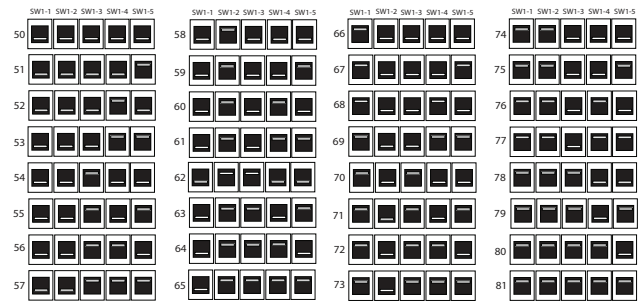

# Direct Spark Ignition Control

## Precedent™ 3 to 10 tons only

This microprocessor based, communicating solid state device provides gas valve control, proof of ignition, ignition retries, 1 hour reset, operation of the inducer, diagnostics through an LED, and communication to the refrigeration module. Inputs to the control include a pressure switch, rollout switch and high temperature limit switch as well as a flame proving circuit.

This device takes control of the ignition, timing related to the ignition cycle, and supervision of the gas components.

The RTRM controls all functions via a MODBUS communication link.

The remote flame sensor is located on the top burner which ensures that all burners are lit. Field measured flame sensor voltage can vary significantly due to the construction of typical voltmeters used.

The control has a 20 second pre-purge cycle as well as a 60 second inter-purge between cycles should a flame not be established on the first try.

**Table 96. Ignition module specifications**

|   |  |
|---|--|
| Voltage range                             | 18-32 VAC, 50/60Hz                             |
| Power consumption                         | 350mA @ 24 VAC                                 |
| Spark Voltage                             | 25,000 volts max @ 10-13 mJ                    |
| Flame sense voltage                       | Nominal 90Vrms                                 |
| Flame sense signal                        | Nominal 4.5 micro amps, minimum 1.2 micro amps |
| Pre-purge                                 | 20 seconds                                     |
| Post-purge                                | 5 seconds                                      |
| Inter-purge                               | 60 seconds                                     |
| Flame establishment period                | 2 to 7 seconds                                 |
| Flame failure response time               | 0.8 seconds                                    |
| Loss of flame lockout                     | 3 tries, locks out after 3rd try               |
| Lockout reset                             | Interrupt power for 3 seconds minimum          |
| Auto reset                                | 1 hour   |
| Loss of communication lockout (with RTRM) | 10 seconds                                     |

The ignition module has a green LED for diagnostics:

**Table 97. Ignition module diagnostics**

|                                    |  |
|------------------------------------|--|
| Steady light                       | Module is powered up, but no active call for heat.   |
| Blinking at continuous steady rate | Active call for heat.  |
| One blink                          | Loss of communication.   |
| Two blinks                         | System lockout (failure to ignite, no spark, low/no gas pressure, etc).  |
| Three blinks                       | Pressure switch (no vent air flow, bad CBM, closed at initial call for heat). Auto reset. (Applicable to 3 to 10 tons units only.)                       |
| Four blinks                        | High limit (excessive heat in combustion chamber, low airflow). Auto reset.  |
| Five blinks                        | Flame sensed and gas valve not energized or flame sensed and no call for heat.   |
| Six blinks                         | Flame rollout (CBM failure, incorrect gas pressure, incorrect primary air). Requires manual reset of the switch. (Applicable to 3 to 10 tons units only) |
| Seven blinks                       | W1& W2 swapped (electromechanical 3 to 10 tons units). ReliaTel™ module will communicate a heat fail diagnostic back to the RTRM.                        |

## Sequence of Operation - Precedent™ 3 to 10 tons Only

### 1-Stage Units

Ignition control (IGN) runs a self check (including verification that the gas valve is de-energized). IGN checks the high limit switch (TCO1) for closed contacts, the pressure switch (PS) for open contacts, flame rollout (FR) for closed contacts.

IGN energizes inducer blower. When PS closes, 20 second pre-purge begins. After 20 seconds, the IGN energizes the spark and gas valve at the same time. The spark will stay energized for at least 2 seconds attempting to establish flame. If a flame is not established, the spark will continue up to 7 seconds. Once a flame is established, spark is de-energized and indoor blower motor (IBM) timing begins. 45 seconds later, the RTRM energizes the IBM. When the zone sensor or thermostat is satisfied, the gas valve is de-energized, the inducer runs for 5 seconds then stops (post-purge), and the IBM runs for 60 seconds then stops unless being requested to run continuously.

### 2-Stage Units

Ignition control (IGN) runs a self check (including verification that the gas valve is de-energized). IGN checks the high limit switches (TCO1 & TCO2) for closed contacts, the pressure switch (PS) for open contacts, flame rollout (FR) for closed contacts.

IGN energizes inducer blower on high speed. When PS closes, 20 second (15 seconds on high, 5 seconds on low)

pre-purge begins. After 20 seconds, the IGN energizes the spark and gas valve at the same time. The spark will stay energized for at least 2 seconds attempting to establish flame. If a flame is not established, the spark will continue up to 7 seconds. Once a flame is established, spark is de-energized and indoor blower motor (IBM) timing begins. 45 seconds later, the RTRM energizes the IBM. If deviation from setpoint is great enough, there is no minimum delay before 2<sup>nd</sup> stage is energized. When the zone sensor or thermostat is satisfied, the gas valve is de-energized, the inducer runs for 5 seconds then stops (post-purge), and the IBM runs for 60 seconds then stops unless being requested to run continuously.

If the burner fails to ignite, the ignition module will attempt two more ignition cycles before locking out. The green LED will indicate a lockout by two fast flashes. An ignition lockout can be reset by:

- Open for 3 seconds and close the main power disconnect switch.
- Switching the mode switch on the zone sensor to off and then to the desired position.
- Allow the ignition control module to reset automatically after one hour.

If the burner trips due to a high temperature limit, the unit will shut down and initiate a four flash diagnostic. After the limit cools down and closes, the burner will again restart. There is no limit to the number of high limit trips that can occur.

Figure 82. Direct spark ignition control sequence of operation

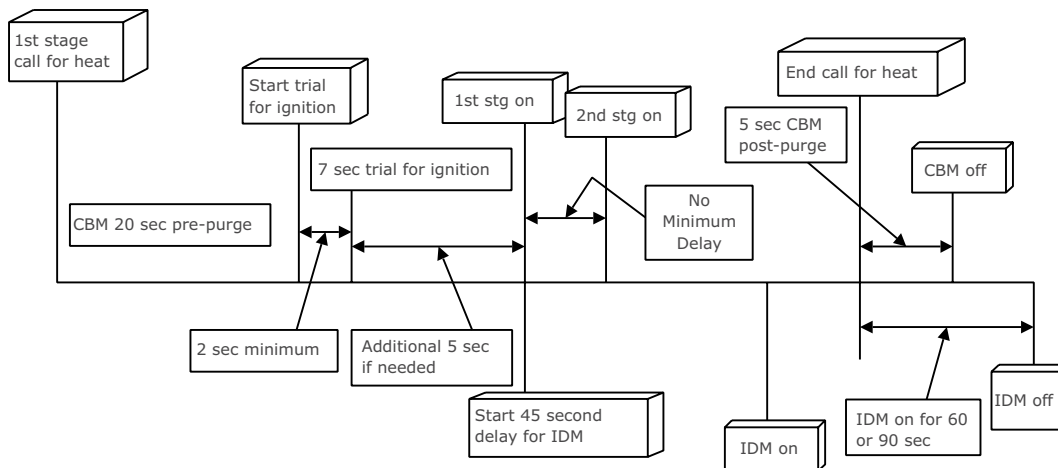

## Precedent™ 6 to 10 Tons Modulating Gas Heat Units

When there is a call for heat, ReliaTel™ will send a command to the ignition module to fire and open the modulating valve to 100% (10.0 Vdc) while also commanding the gas inducer motor to high speed (Valve 2

binary output on the ignition module) and controlling the fan speed to normal algorithm control.

After operating at this condition for the 60 second start-up period, the modulating heat control will be released to normal algorithm control and the valve will begin modulating in the modulating gas heat output operating range between the unit preferred min-fire voltage and the unit max-fire voltage. The modulating gas heat output

## Direct Spark Ignition Control

operating range is determined by the supply airflow measurement.

To keep the heat exchangers from getting too hot or cold, the supply fan airflow is calculated by measuring the differential pressure between the fresh air section and a peizo-electric ring (the transducer is a 0 to 5 in.wc Kavlico transducer) on the supply fan discharge orifice. The resulting airflow will then be standardized to get cfm/ton and used to determine the modulating gas heat output operating range for the valve operation according to the following table.

**Note:** Heating will be discontinued if the supply airflow is less than 175 cfm/ton or if there is a supply airflow sensor failure.

**Table 98. Precedent 6 to 10 tons — modulating gas heat operating range**

| Airflow (CFM/T): | Min Valve Pos % | Max Valve Pos % | Min Valve Com-mand % | Max Valve Com-mand % | Min Fire Voltage | Max Fire Voltage |
|------------------|-----------------|-----------------|----------------------|----------------------|------------------|------------------|
| 175              | 40              | 68              | 0                    | 47                   | 2                | 5.76             |
| 200              | 40              | 70              | 0                    | 49                   | 2                | 5.92             |
| 225              | 40              | 71              | 0                    | 52                   | 2                | 6.16             |
| 250              | 40              | 73              | 0                    | 55                   | 2                | 6.4              |
| 275              | 40              | 75              | 0                    | 58                   | 2                | 6.64             |
| 300              | 40              | 77              | 0                    | 61                   | 2                | 6.88             |
| 325              | 40              | 78              | 0                    | 64                   | 2                | 7.12             |
| 350              | 42              | 80              | 3                    | 66                   | 2.24             | 7.28             |
| 375              | 45              | 82              | 8                    | 69                   | 2.64             | 7.52             |
| 400              | 48              | 83              | 14                   | 72                   | 3.12             | 7.76             |
| 425              | 51              | 85              | 19                   | 75                   | 3.52             | 8                |
| 450              | 55              | 87              | 24                   | 78                   | 3.92             | 8.24             |
| 475              | 58              | 89              | 29                   | 81                   | 4.32             | 8.48             |
| 500              | 61              | 90              | 35                   | 84                   | 4.8              | 8.72             |
| 525              | 64              | 92              | 40                   | 86                   | 5.2              | 8.88             |
| 550              | 67              | 94              | 45                   | 89                   | 5.6              | 9.12             |
| 575              | 70              | 96              | 51                   | 92                   | 6.08             | 9.36             |
| 600              | 73              | 97              | 56                   | 95                   | 6.48             | 9.6              |

**Figure 84. Supply fan airflow peizo-electric ring**

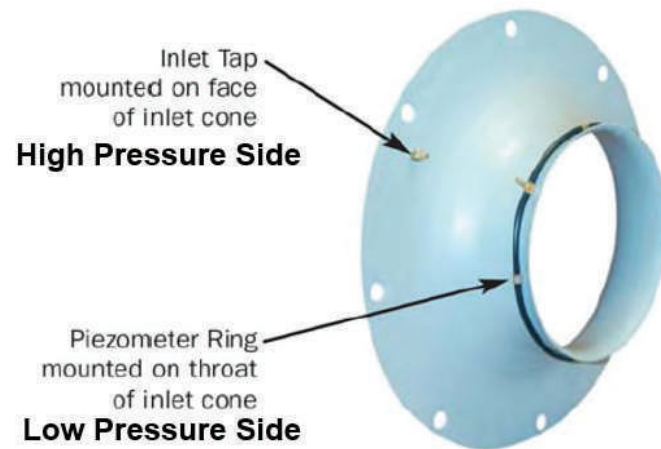

**Table 98. Precedent 6 to 10 tons — modulating gas heat operating range (continued)**

| Airflow (CFM/T): | Min Valve Pos % | Max Valve Pos % | Min Valve Com-mand % | Max Valve Com-mand % | Min Fire Voltage | Max Fire Voltage |
|------------------|-----------------|-----------------|----------------------|----------------------|------------------|------------------|
| 625              | 77              | 99              | 61                   | 98                   | 6.88             | 9.84             |
| 650              | 80              | 100             | 66                   | 100                  | 7.28             | 10               |
| 675              | 83              | 100             | 72                   | 100                  | 7.76             | 10               |
| 700              | 86              | 100             | 77                   | 100                  | 8.16             | 10               |
| 725              | 89              | 100             | 82                   | 100                  | 8.56             | 10               |
| 750              | 92              | 100             | 87                   | 100                  | 8.96             | 10               |
| 775              | 96              | 100             | 93                   | 100                  | 9.44             | 10               |
| 800              | 99              | 100             | 98                   | 100                  | 9.84             | 10               |
| 825              | 100             | 100             | 100                  | 100                  | 10               | 10               |

**Figure 83. Supply fan airflow transducer**

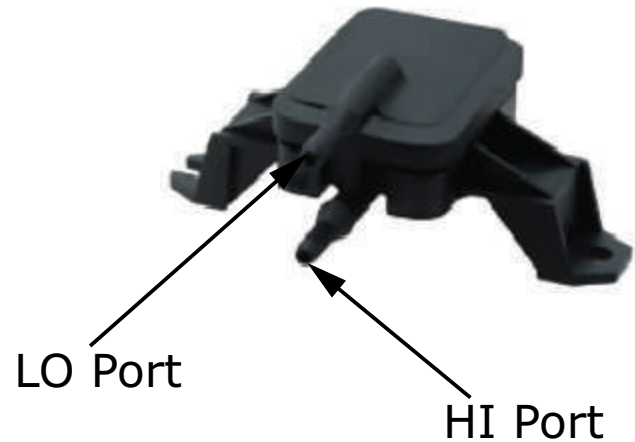

**Note:** Transducer is a 5 Vdc differential pressure transducer with a 0 to 5 in. wc range. The output signal is 0.25 to 4 Vdc.

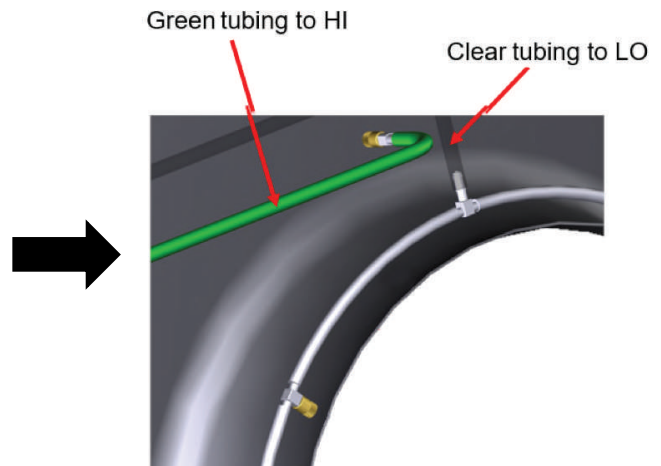
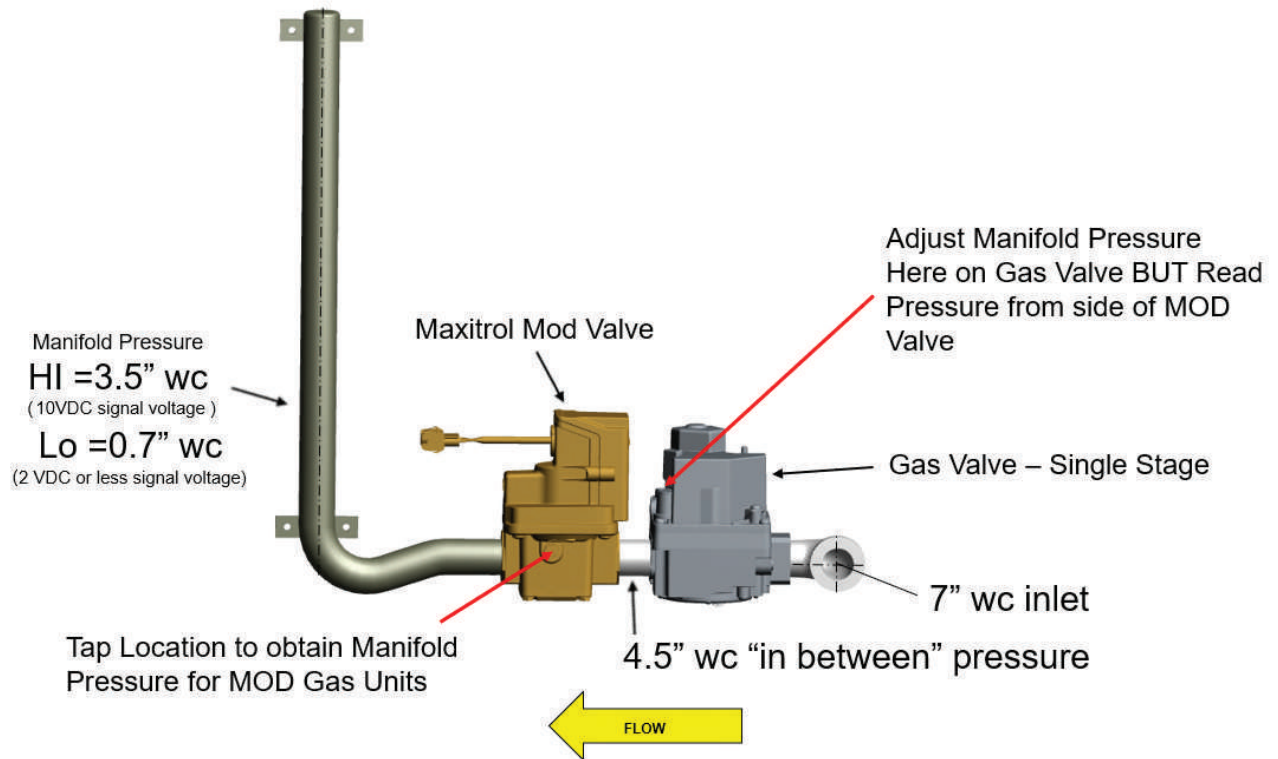

Figure 85. Precedent modulating gas - gas valves



# ReliaTel™ Hot Surface Ignition Control

## 12.5 to 50 Tons, 1 Stage, 2 Stage, and Modulating Gas Heat

This microprocessor based, communicating solid state device provides gas valve control, proof of ignition, ignition retries, one hour reset, operation of the inducer and diagnostics through an LED, as well as communication to the RTRM via a MODBUS communication link. Inputs to the control include high limits and flame sensor operation. A combustion fan proving switch is used with modulating gas heat units but is not used with 1 or 2 stage burners. This device takes control of the ignition, timings related to the ignition cycle, and supervision of the gas components.

**Note:** See the TRG-SVM001\*-EN Light Commercial Rooftop Power Burner - Ignition and Combustion manual for additional details on power burner gas heat and information regarding ignition and combustion.

**Table 99. Ignition module specifications**

|  |   |
|--|---|
| Voltage range                            | 18-32 VAC, 50/60 Hz                         |
| Ignitor voltage                          | 115 VAC, 50/60 Hz                           |
| Flame sense current                      | 4.5 microamps (nominal), 1 microamp minimum |
| Pre-purge                                | 45 sec                                      |
| Flame establishment period               | 2 sec min, 7 sec max                        |
| Flame failure response time              | 0.8 sec or less                             |
| Loss of flame lockout                    | 3 tries, locks out after 3rd try            |
| Lockout reset                            | Interrupt power for 3 seconds minimum       |
| Auto reset                               | 1 hour                                      |
| Loss of communication lockout(with RTRM) | 10 sec                                      |

## Ignition Control Module Diagnostics

There is a green LED located on the ignition module. The table below lists the diagnostics and the status of the LED during the various operating states.

Any time the Ignition module is powered, the LED will be lit to provide status of the ignition system. At initial power-up, the LED will flash for one second.

The pause between groups of flashes for ignition module diagnostic flash codes is approximately two seconds.

Modbus voltage (measure between RTRM J5-3 and J5-4):

- With J5 plug connected, will read approximately 9.6 to 10.7 Vdc (Flashing)

- With J5 unplugged, will read approximately 10.5 to 11.2 Vdc (Flashing).

**Table 100. Ignition module diagnostics**

|                 |  |
|-----------------|--|
| Steady OFF      | No power/Internal failure  |
| Steady ON       | Normal power-up, with no heat call.  |
| Slow flash rate | Normal call for heat, 3/4 second on, 1/4 second off.                           |
| Fast flash rate | Used for error indication only   |
| One flash       | Communication loss between RTRM and IGN  |
| Two flashes     | System lockout; failed to detect or sustain flame                              |
| Three flashes   | Not used   |
| Four flashes    | High limit switch open   |
| Five flashes    | Flame sensed and gas valve not energized; or flame sensed and no call for heat |

## Sequence of Operations (1 and 2 heat units)

The 12.5 to 50 ton packaged units use a drum and tube heat exchanger with a negative pressure gas valve (staged gas heat units) and hot surface ignition. This design is the same as was used with the UCP microcontrols, but the control circuitry for ignitions has changed to take advantage of ReliaTel™ MODBUS communications.

When the system switch is set to the heat position and the zone temperature falls below the heating setpoint, a heat cycle is initiated when the RTRM communicates ignition information to the ignition module (IGN). The ignition module green LED will blink a heartbeat flash when during heating operation mode.

The IGN runs a self-check (including verification that the gas valve is de-energized). IGN checks the high-limit switches (TC01 and TCO2) for normally closed contacts. With 115 Vac supplied to the ignition module (IGN), the hot surface ignitor probe (IP) is preheated for approximately 45 seconds. The gas valve (GV) is energized for approximately 7 seconds for trial ignition to ignite the burner.

Once the burner is ignited, the hot surface ignition probe (IP) is de-energized by the ignition module and then functions as the flame sensor. The unit initially fires on high heat, but after approximately 60 seconds, if no additional heating is required, the ignition module will drop back to low heat.

When the fan selection switch is set to the auto position, the RTRM energizes the indoor fan relay (F) approximately 45 seconds after initiating the heating cycle to start the indoor fan motor (IDM).

If the burner fails to ignite, the ignition module will attempt two more ignition cycles before locking out. The green LED

will indicate a lockout by two fast flashes. An ignition lockout can be reset by:

- Open for 3 seconds and close the main power disconnect switch.
- Switch the mode switch on the zone sensor to off and then to the desired position.
- Allow the ignition control module to reset automatically after one hour.

If the burner trips due to a high temperature limit, the unit will shut down and initiate a four flash diagnostic. After the limit cools down and closes, the burner will again restart. There is no limit to the number of high limit trips that can occur.

When the RTRM is communicating with the ignition module (IGN), the MODBUS voltage can be measured at the 3J5 plug, pins 3 (negative) and 4 (positive). The voltage will be flash at approximately 10.7 to 9.6 Vdc at a rate of once every three seconds. If the 3J5 plug is disconnected, the measured voltage at pins 3 and 4 on the RTRM will be approximately 10.5 to 11.2 Vdc and will be flashing. Flame current measurements can also be made at two pins on the ignition module labeled FLAME CHECK located at the bottom of the module. Flame current can be measured with a DC voltmeter. One volt dc equals one microamp of flame current (1 Vdc = 1µA).

27.5 to 50 tons high heat units use two drum and tube heat exchangers. Two ignition controls work in tandem to provide heat as required.

Figure 86. ReliaTel™ hot surface ignition control sequence of operation

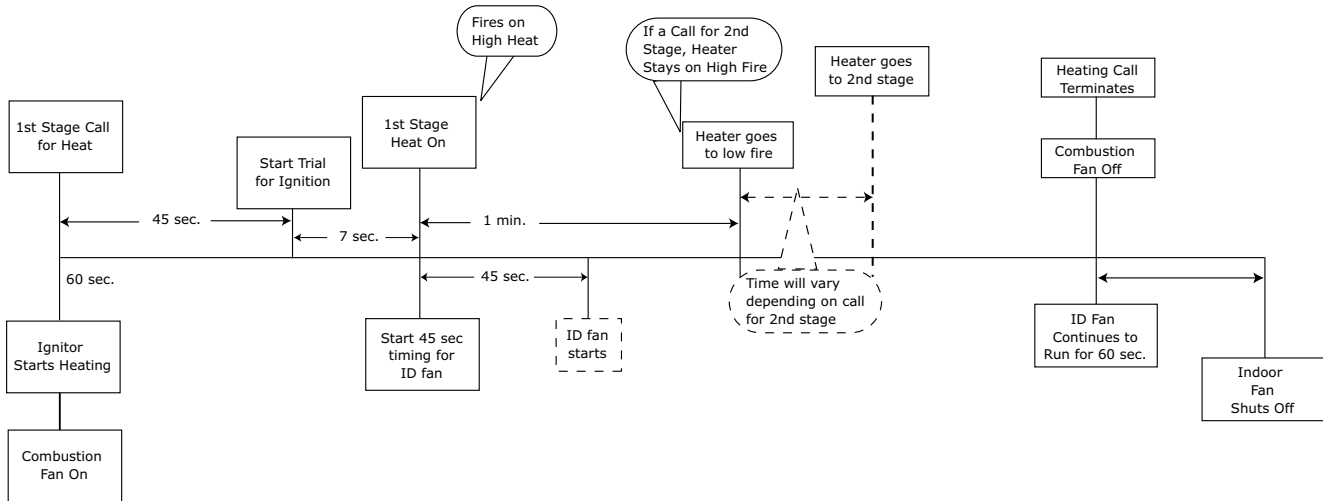

Modulating heat units utilize a variable speed combustion blower motor that enables the motor to operate at the

necessary speed required to provide the amount of heat required to satisfy the current heating load of the building.

Figure 87. Fasco CFMB modulating gas control board

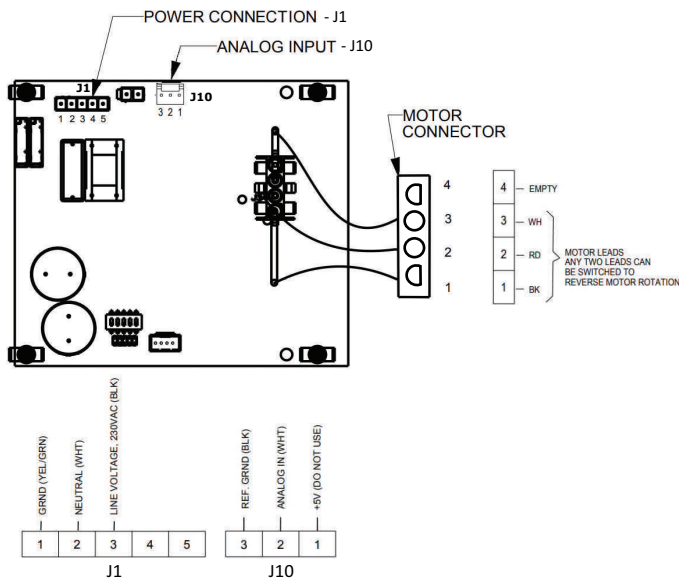

**Figure 88. IMC CFMB modulating gas control board**

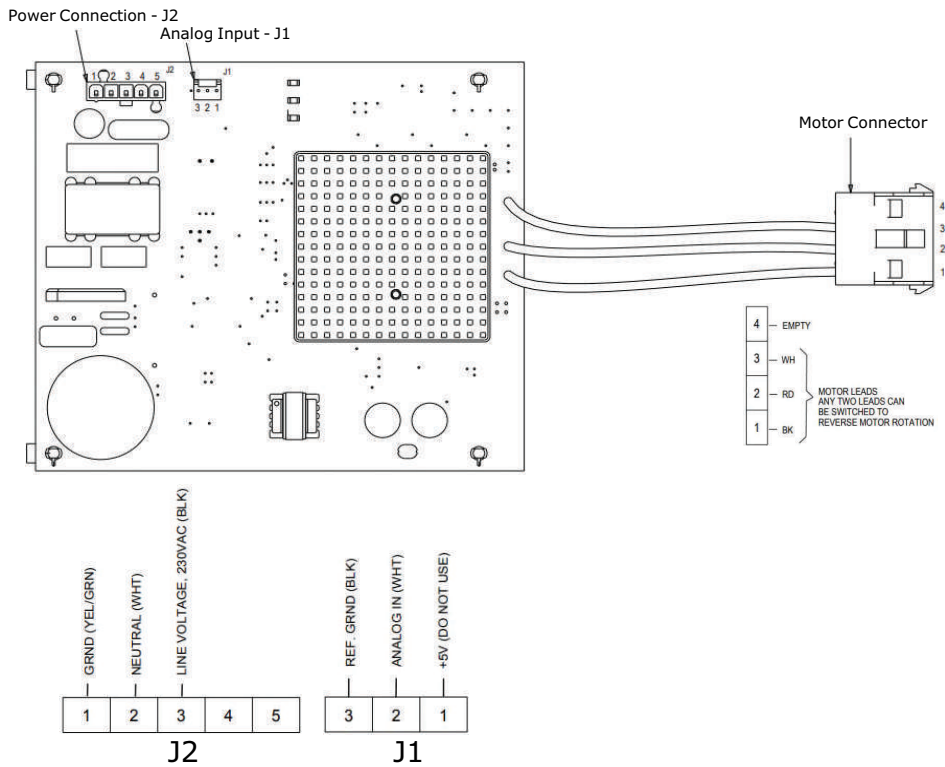

**Table 101. Modulating gas heat motor control board fault codes**

| Flash Code    | Fault           |
|---------------|-----------------|
| LED on Steady | No Faults       |
| 1 Flash       | Not Used        |
| 2 Flashes     | Undervoltage    |
| 3 Flashes     | Overvoltage     |
| 4 Flashes     | Overtemperature |

**Table 101. Modulating gas heat motor control board fault codes (continued)**

| Flash Code | Fault          |
|------------|----------------|
| 5 Flashes  | Overcurrent    |
| 6 Flashes  | Motor Overload |

**Note:** Fault LED flashes at a rate of 1/4 second ON and a 1/4 second off with a 5 second pause.



# Heat Pump

## Demand Defrost

There are two schemes in common usage for heat pump outdoor coil defrosting: demand defrost and time-temperature defrost. Demand defrost is more efficient because defrost cycles are initiated only when necessary, compared with initiation based on operating time below the threshold temperature. All packaged heat pumps use demand defrost.

There are three conditions that must be met for demand defrost to operate:

- Heating mode with compressor(s) operating.
- Outdoor ambient is less than 52°F.
- Outdoor coil is less than 33°F on any circuit.

**Figure 89. Typical demand defrost cycle**

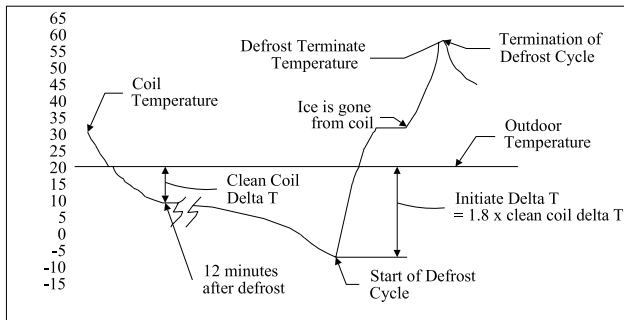

## Defrost Service Test

When a service test defrost request is received, defrost mode is initiated immediately. The defrost cycle will remain active for a minimum of 1 minute, after which the normal termination will occur when the coil temperature exceeds the defrost termination temperature as defined below. The service test defrost request will remain active for a maximum of 10 minutes, after which the unit will transition out of the defrost step as described below.

## Defrost Mode Operation

Demand defrost is standard feature which permits defrost whenever coil icing conditions begin to significantly reduce unit capacity. To permit defrost, the outdoor temperature must be below 52°F and coil temperature must be below 33°F. The first defrost cycle after power-up is initiated based on 30 minutes of cumulative operating time in heat at the already stated temperature conditions. After the necessary run time under defrost permit conditions, the RTRM initiates a defrost cycle.

During the defrost cycle, the RTRM energizes the relay (K3), which energizes the switch over valve (SOV) through the normally open K3 relay contact. This will then turn the outdoor fan motor(s) (ODM) 'Off' by de-energizing the (K8) and (K7) relays, which de-energizes the (ODF) relays. The RTRM energizes the auxiliary electric heat contactor (AH),

if not already operating, while maintaining compressor operation. For dual fuel heat pumps, gas heat is enabled while defrost is operating.

Defrost mode shall remain active until the outdoor coil temperature (OCT) exceeds the defrost termination temperature (DTT) or 10 minutes have passed, whichever occurs first. If all compressor outputs turn off during the defrost cycle, such as during a high pressure cutout, defrost mode will terminate.

The defrost cycle is terminated based on the RTRM termination temperature calculation using the outdoor temperature (OAT) +47°F. The defrost termination temperature (DTT) will be limited between 57°F and 72°F. Termination of the defrost cycle includes a soft start delay. At the end of each defrost cycle, the outdoor fan comes on 5 seconds before the reversing valve is de-energized. This reduces stress on the compressor and makes for a quieter defrost. After the defrost mode has terminated, the defrost function will track 12 minutes to assure that a dry coil condition has been achieved. At the 12 point, the Clean Coil Delta T will be calculated using the current values of OAT and OCT (OAT is expected to be higher than OCT). This value is multiplied by 1.8 to calculate the new Initiate Delta T Value and this value is stored in the memory of the RTRM. The RTRM monitors the outdoor temperature (OAT) and the coil temperature (CT) and calculates the  $\Delta T$  (OAT-CT). The RTRM continually compares the  $\Delta T$  to the defrost initiate Delta T value. Once the  $\Delta T$  reaches the Initiate Delta T Value, a defrost cycle is once again initiated.

## General Sequence of Operation

When the system switch is set to the heat mode, the RTRM energizes relay (K3). When the normally open (K3) contacts open, the switch over valves (SOV1 and 2) are de-energized. When the zone temperature falls below the heating setpoint control band, the RTRM energizes the (K9) and (K10) relay coils on the RTRM. When the (K9) relay contacts close, the compressor contactor (CC1) coil is energized provided the low pressure control (LPC1), high pressure control (HPC1) and discharge line thermostat (TDL 1) are closed. When the (K10) relay contacts close, the compressor contactor (CC2) coil is energized provided the low pressure control (LPC2), high pressure control (HPC2) and discharge line thermostat (TDL 2) are closed. The outdoor motor(s) are also started during the heating cycle.

The RTRM smart recovery function monitors the rate at which the zone temperature is changing every 9 minutes during the operating heating cycle. If the zone temperature is rising at a rate greater than 6°F per hour, no additional heat is requested (auxiliary heat). If not, the RTRM energizes the first stage auxiliary heat. A minimum of 10 seconds off time must have elapsed between heater cycles. If mechanical heat and first stage auxiliary heat cannot provide the 6°F recovery rate, the RTRM energizes

## Heat Pump

second stage auxiliary heat, if applicable. The RTRM continues to monitor the rate of change and stages the electric heat off as it determines that the mechanical heat (compressor operation) is sufficient.

Auxiliary heat for a dual fuel unit is gas heat. During normal mechanical heating the switchover valve output(s) is turned off and all compressors and condenser fans are turned on to perform heating as under normal heat pump control described above. If auxiliary heat is necessary, the mechanical heat (compressors) will be de-energized and the unit will operate as a staged gas heat unit.

Auxiliary heat for dual fuel units are also enabled or disabled by smart recovery. Smart recovery dictates that if the active zone temperature is making a recovery toward the active setpoint at a rate of at least 6°F/hour (0.1°F/minute), auxiliary gas heat is disabled. If the active zone temperature is not making a recovery toward set point at a rate of at least 6°F, the gas heat will be enabled. Stages of gas heat are enabled as necessary to meet heating demand. When auxiliary gas heat is energized to meet demand, mechanical heating is turned off.

### Emergency Heat Operation

When the system selection switch is in the EM HEAT Mode, and the zone temperature falls below the heating setpoint controlband, the RTRM bypasses compressor and outdoor fan operation and energizes the K1 relay located on the RTRM. When K1 relay contacts close, the first stage auxiliary electric heat contactor (AH) is energized. If the first stage of auxiliary electric heat cannot satisfy the heating requirement, the RTRM energizes the K2 relay located on the RTRM. For dual fuel heat pumps, the gas heat is enabled and stage up and down based on the heating requirements for the zone.

### Diagnostic Information

Demand defrost also tracks failures and operating problems as follows:

When the K2 relay contacts close, the second stage auxiliary electric heat contactor (BH) is energized. The RTRM cycles both the first and second stages of heat on and off as required to maintain the zone temperature setpoint.

Correct defrost operation relies on accurate temperature information from the outside air sensor (OAT) and the coil temperature sensors (CTS).

If both of these sensors fail, the unit will revert to the default mode any time the unit is in the active heat mode with compressors running.

If only one of the sensors fail and the remaining valid sensor is below defrost permit conditions (CTS<33°F or OAT<52°F), the unit will revert to default mode any time the unit is in the active heat mode with compressors running. If the valid sensor is above defrost permit conditions, the defrost operation will be disabled.

When any defrost fault is active, or if any sensor has failed, the heat pump will revert to defrost default mode. The

default mode is defined as a 5 minute defrost cycle that will be initiated after each 30 minutes of cumulative compressor heating operation.

**Table 102. Demand defrost fault designation**

| Symptom  | Diagnostic                    | Response  |
|--|-------------------------------|---|
| Coil temperature Sensor Failure  | Sensor is shorted or open     | Activate Defrost Fault  |
| Outdoor Temperature Sensor Failure   | Sensor is shorted or open     | Activate Defrost Fault  |
| DT is below Minimum Value 12 minutes after defrost is terminated   | "Fault A"<br>Low DT           | If > 2 hours, activate Defrost Fault Reset timer if DT returns within bounds.   |
| Defrost Terminated on time requirement   | "Fault B"<br>Time Termination | If defrost is terminated on time requirement (vs. differential temperature) After 10 consecutive Time Terminations, activate Defrost Fault. |
| DT is above Maximum Value 12 minutes after defrost is terminated   | "Fault C"<br>High DT          | Initiate Defrost. After 16 consecutive High DT Initiations activate Defrost Fault.  |
| DT does not change by 2 degrees in an hour's time starting 12 minutes after defrost is terminated and DT is less than or equal to 4 degrees 12 minutes after defrost is terminated | "Fault D"<br>Unchanging DT    | Initiate Defrost and activate Defrost Activate Defrost Fault  |

**Notes:**

1. Defrost termination temperature (DTT) = Outdoor air temperature (OAT) + 47°F
2. 57°F ≤ DTT ≤ 72°F
3. Defrost temperature (DT) = Outdoor air temperature (OAT) – Outdoor coil temperature (OCT)
4. Defrost initiate temperature = 1.8 x DT (only initiates after a minimum of at least 12 minutes after the previous defrost mode has ended)

High and low delta T's are defined as follows:

**Table 103. High and low delta T's**

| Outdoor Air Temp  | High Delta T (Non-V3) | High Delta T (V3) | Low Delta T |
|-------------------|-----------------------|-------------------|-------------|
| OAT > 45°F        | 30                    | 34                | 2.2         |
| 45°F > OAT > 39°F | 29                    | 32                | 1.6         |
| 39°F > OAT > 32°F | 28                    | 32                | 1.6         |
| 32°F > OAT > 26°F | 25                    | 28                | 1.1         |
| 26°F > OAT > 19°F | 22                    | 26                | 0.5         |
| 19°F > OAT > 13°F | 21                    | 22                | 0.5         |
| 13°F > OAT > 6°F  | 18                    | 21                | 0.5         |

**Note:** Below 6°F the Delta T's are ignored. At this point, the initiate temp is still 1.8\*ΔT below the OAT, but the ΔT initiate is clamped between 6 and 17.

### Independent Circuit Defrost Operation

For EMEIA independent circuit heat pump units with two outdoor coil temperature sensors, the unit will perform defrost per circuit based on its own coil temperature sensor value, the outdoor ambient temperature, and the accumulated circuit run time. At least one stage of auxiliary heat will be energized anytime either circuit is in defrost mode. All other defrost functionality, including the diagnostic conditions, will perform as described above independently per circuit.

### ReliaTel™ Heat Pump Low Ambient Limit

The RTOM provides a heat pump low ambient limit input on J12-1 that, when grounded, disables mechanical

(compressor based) heating below a certain outdoor temperature. On newer versions of RTRM, the low ambient limit can be configured using a TD5 or BCIR configurable setpoint.

On RTRM V20 (and earlier), this low ambient limit temperature was 1.4°F on all heat pump units.

On Precedent™ heat pump units with RTRM v21 and later, the low ambient limit setting is 30°F. On Voyager heat pump units, the low ambient limit remains at 1.4°F. Also, with the newer versions, a TD5 or BCIR can be configured to set the low ambient limit with a range of 0 to 45°F.

# Economizer

## ReliaTel™

### Economizer Module Layout

**Note:** Honeywell (obsolete - not available to order).

The economizer module plugs directly onto the top of the actuator. It has a diagnostic LED, which under normal operation is either on (OK to economize) or flashing (Not OK to economize). It communicates via MODBUS with the RTRM, and receives outside air temperature input from the RTRM. Mixed air sensor (MAT), return air sensor (RAT), outdoor humidity sensor (OAH), and return humidity sensor (RHS) are all plugged directly into the RTEM. The application section of this manual shows how to apply a CO<sub>2</sub> sensor.

A new stripped down version of the RTEM module was implemented in April, 2005 which only contains the MAT,

input, min. pos. adjustment and the wire plug for power and ModBus communications. This module will only be applied on units that are supplied from the factory without any economizer options such as, reference enthalpy, comparative enthalpy or CO<sub>2</sub>. Options installed in the field will require the full-up version in order to operate properly.

- To read the actual damper position, read the DC voltage at the 2-10 Vdc feedback input terminals. 2 Vdc is closed, 10 Vdc is 100% open. Refer to [Table 104, p. 146](#).
- To drive two actuators with one control, connect field wiring as shown in [Figure 90, p. 144](#).

**Note:** Remote minimum position input does not work when a CCP is controlling the unit.

**Figure 90. ReliaTel™ economizer module layout (Honeywell)**

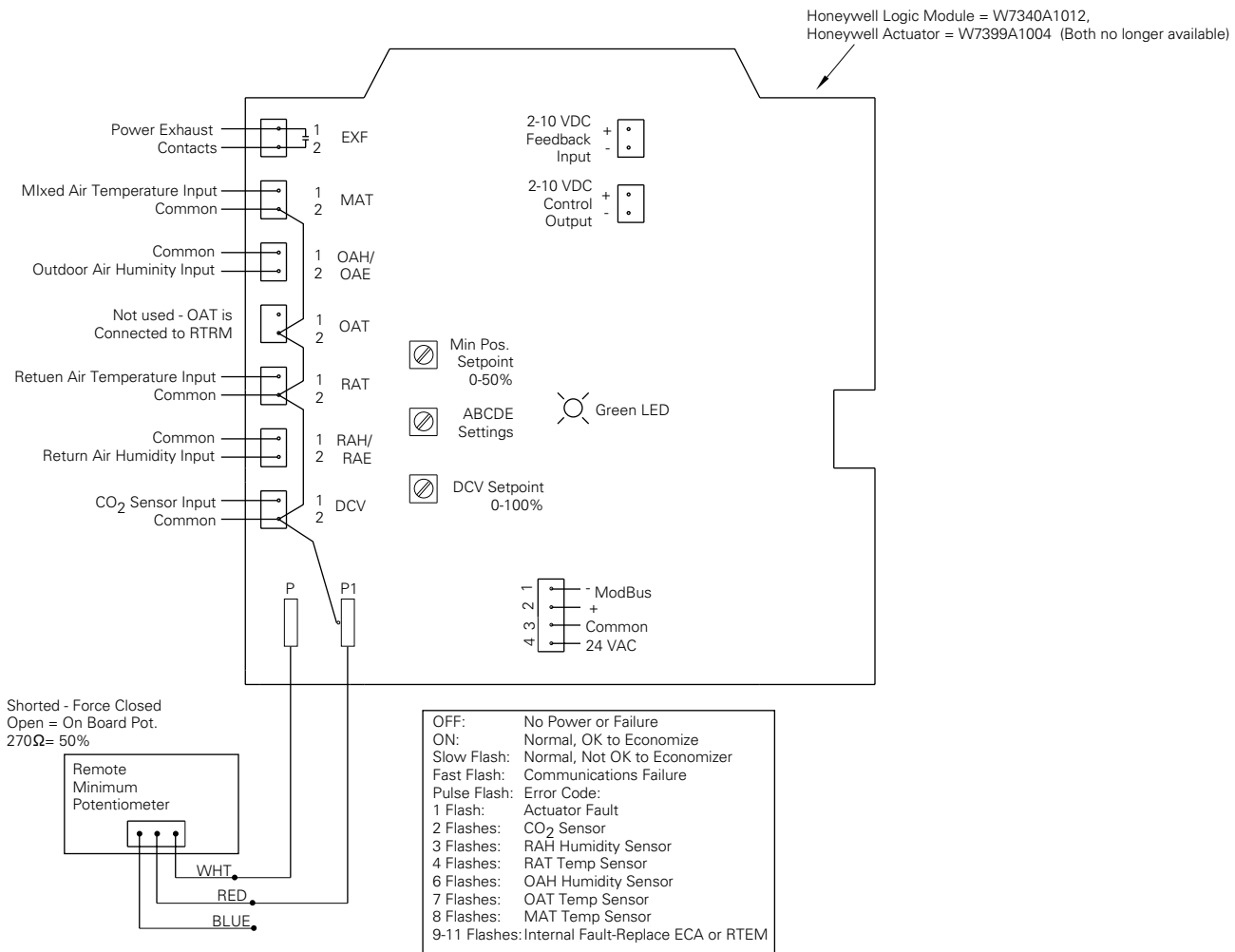

## ReliaTel™ Economizer Layout - RTEM

The RTEM module plugs directly onto the actuator. It has a diagnostic LED, which under normal operation is either on (ok to economize) or flashing (not ok to economize). It communicates via MODBUS with the RTRM, and receives an outside air temperature input from the RTRM. Mixed air sensor (MAT), return air sensor (RAT), outdoor humidity sensor (OAH), and return humidity sensor (RAH) are all plugged directly into the RTEM. The application section of this manual shows how to apply a CO<sub>2</sub> sensor.

A stripped down version of the RTEM, which only contains the MAT input, design minimum position adjustment, remote minimum position input, enthalpy setpoint, and the wire plug for power and ModBus communications, is also available. This module will only be applied on units that are supplied from the factory without any economizer options such as, reference enthalpy, comparative enthalpy or CO<sub>2</sub>.

Options installed in the field will require the "full-up" version in order to operate properly.

- To read the actual damper position, read the DC voltage at the 2-10 Vdc Damper Position' input terminals; 2 Vdc is closed, 10 Vdc is 100% open.
- To drive two actuators with one control, connect field wiring as shown in [Figure 91, p. 145](#).

**Notes:**

- Remote minimum position input does not work when a CCP is controlling the unit.
- The gray ReliaTel™ RTEM economizer module is not compatible with the black Honeywell actuator. The terminal connections on the back do not interface correctly with the older black Honeywell actuator (W7399A1004 style).

**Figure 91. ReliaTel™ economizer module layout (RTEM) — MOD03099**

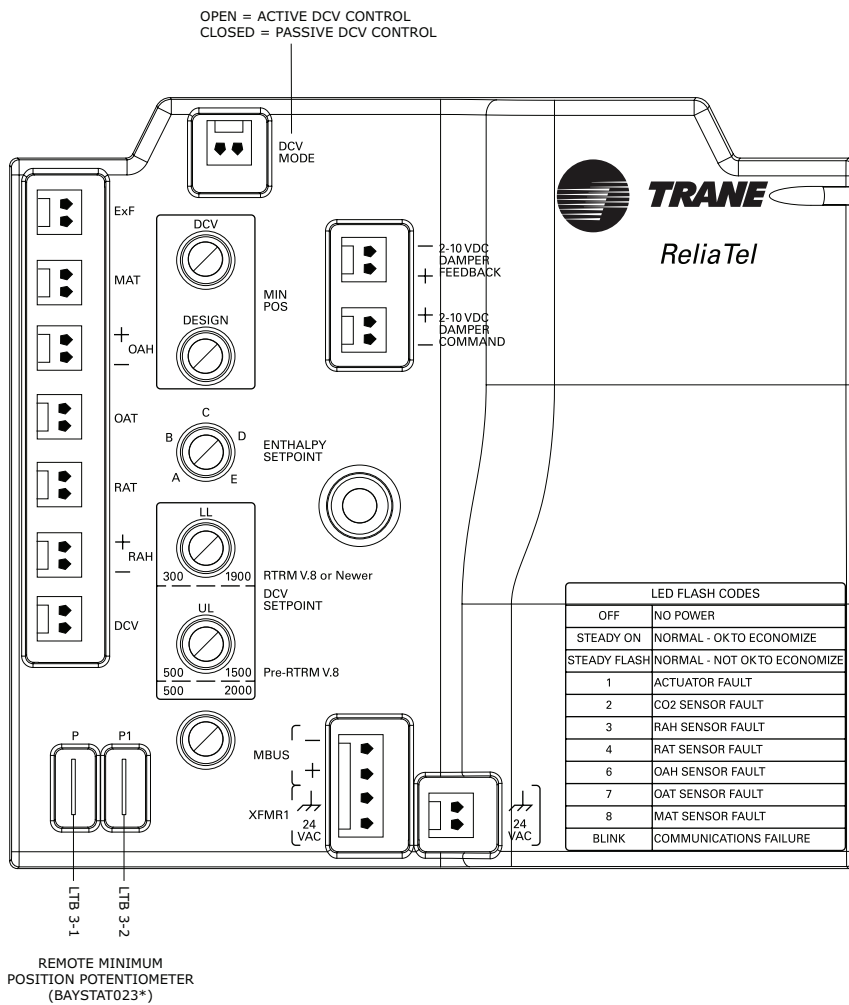

# Economizer

**Table 104. Economizer OA damper position vs. feedback voltage**

| Feedback Voltage Output (VDC) | OA Damper Position |
|-------------------------------|--------------------|
| 2.0                           | 0%                 |
| 2.8                           | 10%                |
| 3.6                           | 20%                |
| 4.4                           | 30%                |
| 5.2                           | 40%                |
| 6.0                           | 50%                |
| 6.8                           | 60%                |
| 7.6                           | 70%                |
| 8.4                           | 80%                |
| 9.2                           | 90%                |
| 10.0                          | 100%               |

## Economizer Module and Actuator Layout

*Note: Used on electromechanical Foundation™ and Precedent™.*

Electromechanical economizers since August 2014 (gray) use the ReliaTel™ actuator.

**Figure 92. Electromechanical economizer module layout (RTEM-EM) — MOD02399**

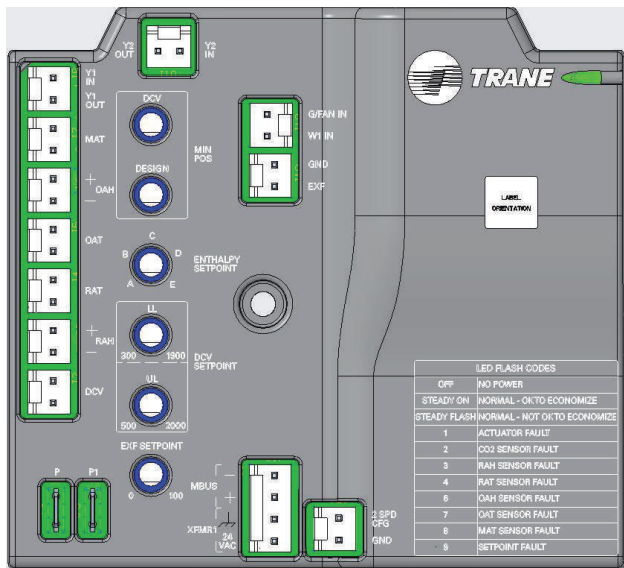

**Figure 93. ReliaTel™ economizer actuator terminals — MOD01301**

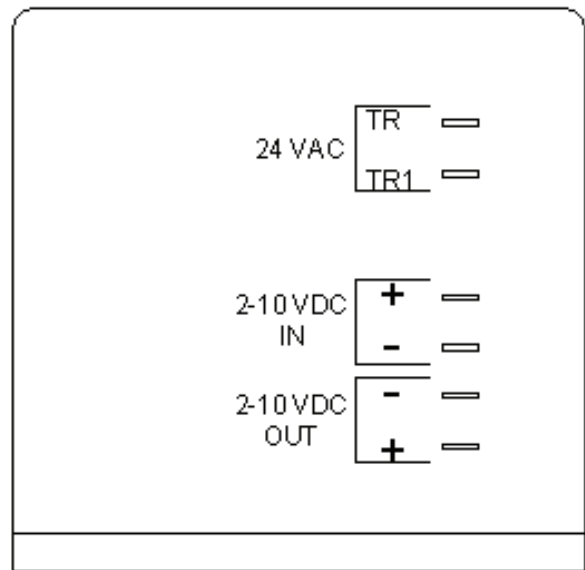

*Note: The ReliaTel™ gray economizer actuator is not compatible with the black Honeywell logic module. The terminal connections on the actuator do not interface correctly with the older black Honeywell logic module (W7340A1012 style).*

Figure 94. Low leak economizer (LLE) - typical wiring

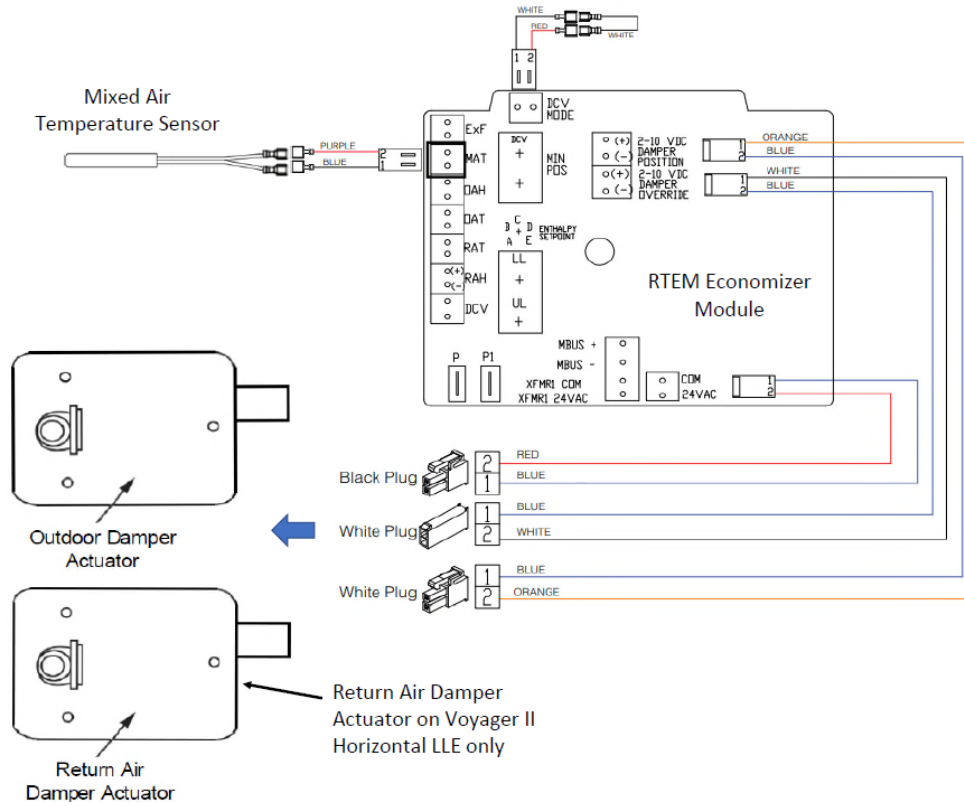
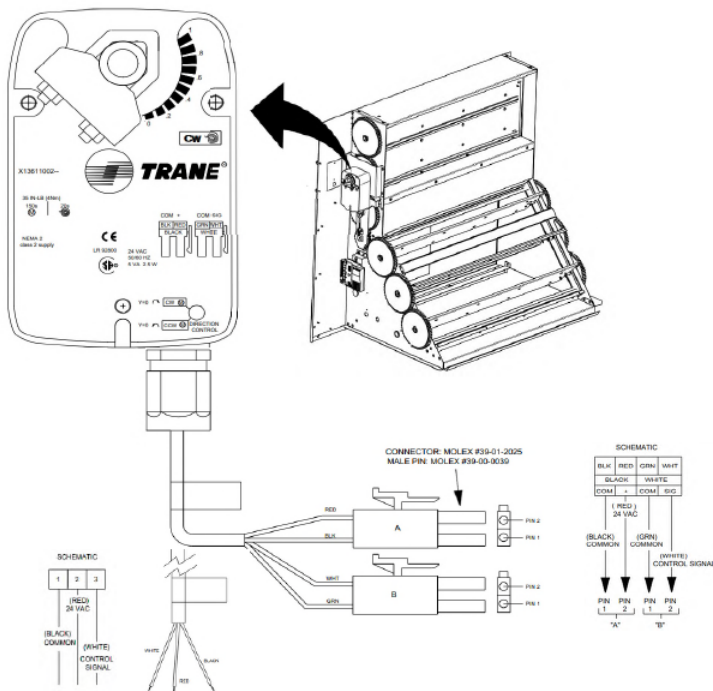

Figure 95. Low leak economizer (LLE) - actuator



### VAV Economizer Cooling Operation

A similar method of determining and adjusting the economizer setpoint as described in CV operation will be used in VAV cooling operation with the additional VAV requirements below.

- Economizer Setpoint = SA Temp Control Point - 2°F.
- Economizer Cooling is only allowed when economizing is enabled and SA temp is greater than Economizer Setpoint - 1.5°F.
- If conditions allow enabling of economizer cooling after a compressor is active, the economizer damper is forced to 100% open until all compressors are deactivated or conditions change to disable economizing.
- If economizer cooling is active prior to mechanical cooling, compressor operation will be inhibited until the economizer damper reaches 100%. Once the economizer reaches 100%, mechanical cooling will be enabled without delay.
- During VAV unoccupied operation economizer cooling will operate as it does in CV unoccupied.

### Economizer Operation with Zone Sensor, Programmable Zone Sensor or ICS

When economizing is enabled and the unit is operating in the cooling mode with a zone sensor, the economizer damper is modulated between its minimum position and 100% to maintain the zone temperature at the economizer setpoint.

When the unit is applied with a zone sensor, programmable sensor or ICS, the economizer setpoint (ESP) is derived from the cooling and heating setpoints (CSP and HSP) so that ESP is the higher of 1) CSP - 1.5°F or 2) HSP + 1.5°F.

When enabled, the economizer will modulate between minimum position and 100% to maintain the mixed air temperature to the calculated mixed air setpoint (53°F minimum). If the mixed air temperature starts to fall below the mixed air setpoint, the economizer starts closing. If the mixed air temperature falls to 50°F or below, the damper will close to the minimum position.

If the economizer is not able to satisfy the cooling setpoint, 1<sup>st</sup> stage cooling will be energized. Should the cooling setpoint not be satisfied with 1<sup>st</sup> stage cooling, 2<sup>nd</sup> stage cooling will be energized. Most often, the economizer and 1<sup>st</sup> stage cooling will be adequate to satisfy the load. 1<sup>st</sup> stage cooling will not start until the economizer has been full open for five minutes on a non-V3 (3 minutes if the unit is a V3) and the zone temperature error has not been reduced quickly enough.

### Economizer Operation with Conventional Thermostat (CV Only)

When the unit is operating from a conventional thermostat or other binary input, the economizer setpoint feature, relative to the cooling and heating setpoints, is lost.

The economizer control is based strictly on a signal from the thermostat, but still maintains mixed air temperature control of 53° ±3°F when in the economizer mode. The economizer enable and disable function is still determined by the outside air sensor through the RTRM.

If a single-stage thermostat is used, only the economizer (if enabled) or the compressor (if economizer is disabled) will operate on a call for cooling. A two-stage thermostat is required to achieve economizer operation and compressor operation at the same time.

With the economizer enabled, a Y1 call for 1<sup>st</sup> stage cooling will be the economizer. The damper will modulate between minimum position and 100% to maintain mixed air temperature at 53° ±3°. At 50°F the damper will be at minimum position. If the economizer is enabled, a Y2 call for 2<sup>nd</sup> stage cooling will start the first compressor only if the economizer damper is at 100% open continuously for 5 minutes on a non-V3 (3 minutes if the unit is a V3).

If the economizer is disabled, 1<sup>st</sup> stage (Y1) will be the first compressor. If the unit has two compressors, a call for 2<sup>nd</sup> stage cooling (Y2) will start the second compressor.

When using a conventional thermostat, or other binary input, the ReliaTel™ controls will only allow two stages of cooling.

*Note: Precedent™ LLE wire numbers shown.*

### Barometric Relief

Units with economizers bring in outside air for ventilation and/or economizer cooling. Because the economizer contains a return air damper that operates inversely to the outdoor air damper, the outdoor air will tend to pressurize the conditioned space. This can cause exterior doors to open or audible noise from air escaping through various building openings.

Units without exhaust fans rely on barometric dampers to vent the pressure that builds up in the space due to outdoor airflow.

*Note: Power exhaust cannot add with barometric relief installed. Barometric relief and power exhaust are mutually exclusive.*

### Motorized 0-50% Outside Air Damper

The motorized damper is utilized to provide outside air into the space, outside air is drawn in through the outside air damper and delivered to the space to maintain a slight positive indoor building pressure or to bring in outdoor air to prevent poor indoor air quality conditions. This ventilation air is provided through an outdoor air (OA) damper.

Anytime the indoor fan motor (IDM) is operating, the motorized damper opens to the minimum position setpoint.

The amount of outside air is determined by the outside air damper minimum position setting which can only be set to a maximum position of 50% open.

To adjust the minimum position setpoint, turn the potentiometer located on the ECA/RTEM, labeled MIN POS SETPOINT 0-50% on the ECA or DESIGN on the



RTEM, clockwise to open (increase ventilation amount) or counterclockwise to close (decrease ventilation amount).

The mixed air temperature sensor (MAT) is not used when a motorized damper is installed. The ReliaTel™ RTEM module will always display an active eight-flash diagnostic code on a motorized damper due to not having a mixed air temperature sensor connected (MAT).

A motorized damper only has an outside air (OA) damper and does not have a return air (RA) damper.

## Power Exhaust

Exhaust fans offer improved performance since they can be sized to overcome the pressure drops associated with the return duct that would otherwise add to the space pressure. This function allows the exhaust fan to operate when appropriate to maintain space pressure.

**Units without RTOM** - The power exhaust is on whenever the economizer damper is at 25% outside air or greater. This is not adjustable. The power exhaust is off whenever the economizer damper is below 15%. This is not adjustable.

**Units with RTOM** - The power exhaust set point (point at which the power exhaust is turned on) is adjustable from 0% to 100% at the RTOM “exhaust setpoint” potentiometer. The power exhaust will be off when the economizer damper falls below the power exhaust setpoint - 10%.

**Power Exhaust with Fresh Air Tracking (27.5 to 50 tons)** - The modulating power exhaust actuator tracks the position of the economizer damper actuator such that the power exhaust dampers proportionally follow or track the fresh air damper position. Exhaust fan is energized same as standard power exhaust option.

**Power Exhaust with Statitrac (27.5 to 50 tons)** - The exhaust actuator will operate independently of the economizer in order to relieve positive building pressure. A pressure transducer is used to measure and report direct space (building) static pressure. If a space pressure transducer failure occurs, the unit will revert back to fresh air tracking control. See sequence of operation below.

### Notes:

- *The exhaust enable setpoint will need to be selected as on units with standard power exhaust control.*
- *Do not add barometric relief with power exhaust installed. Power exhaust and barometric relief are mutually exclusive.*

**Figure 96. ReliaTel™ RTEM power exhaust control wiring**

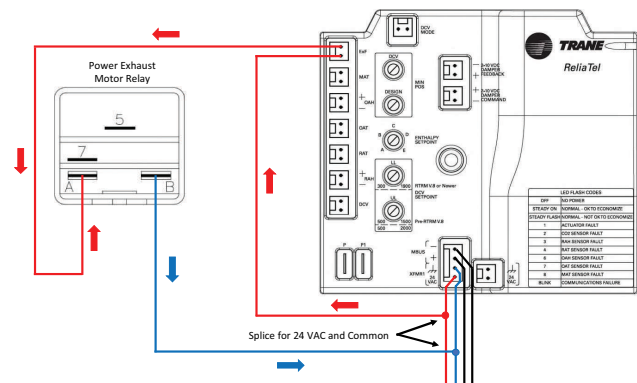

## Statitrac Sequence of Operation

When the exhaust enable setpoint is reached, the exhaust fan control algorithm is activated. If space pressure is equal to the programmed space pressure setpoint +/- 50% space pressure dead band set point, the exhaust fan and dampers will be inactive.

If space pressure increases above the space pressure setpoint + 50% of the space pressure dead band setpoint, the control algorithm will turn on the exhaust fan and modulate the exhaust fan damper to relieve building pressure.

When space pressure decreases to within the space pressure setpoint +/- 50% of the space pressure dead band setpoint, the exhaust fan damper position will remain constant. If the space pressure falls below the space pressure setpoint - 50% of the space pressure dead band setpoint, the control algorithm will deactivate the exhaust fan dampers or VFD.

**Note:** *Due to the control algorithm the exhaust fan may not immediately inactivate after the exhaust dampers are at 0% closed and could potentially run up to 30 minutes before eventually turning off.*

## Economizer Control Methods

Three different methods can be used to determine if outdoor air contains more cooling capacity than the return air and are described below. The different methods are suited for different applications and environments.

- **Comparative Enthalpy** - Outdoor air enthalpy is compared with return air enthalpy. This method is best suited for high humidity climates and applications in which humidity can affect the cooling capacity of the outdoor air or return air.
- **Reference Enthalpy** - Outdoor air enthalpy is compared with a reference enthalpy point. This method is best suited for high humidity climates in which humidity can affect the cooling capacity of the outdoor air, but not necessarily the return air.
- **Reference Dry Bulb** - Outdoor air temperature is compared with a user set reference temperature. This

method is best suited for low humidity climates and applications in which humidity does not strongly affect cooling capacity of the outdoor air or return air.

Dry bulb temperature and relative humidity data are used to determine enthalpy.

Economizer-based cooling is enabled only when outdoor air is determined to have more cooling capacity than the return air. The method used is according to the available data. When temperature and humidity data are available for the outdoor air and return air, the comparative enthalpy method is used. One of the other methods are used if data is invalid or unavailable. Ultimately, when there is insufficient data to use any of the three methods, economizer-based cooling is disabled.

### Economizers with Traq (27.5 to 50 tons)

The outside air enters the unit through the Traq sensor assembly and is measured by velocity pressure flow ring. The velocity pressure flow ring is connected to a pressure transducer/solenoid assembly. The solenoid is used for calibration purposes to compensate for temperature swings that could affect the transducer. The ReliaTel™ ventilation module (RTVM) utilizes the velocity pressure input, the outdoor air temperature input, and the minimum outside air cfm setpoint to control the volume (cfm) of outside air entering the unit as the measured airflow deviates from setpoint.

The algorithm used for this function will be P+I, with integration occurring only when outside the deadband. As long as the measured airflow is within the deadband, the control will be satisfied. When the OA CFM value is above the upper deadband limit the algorithm will decrease the Traq OA Min Damper Position Request allowing less fresh air into the space. When the OA CFM value is below the lower deadband limit the algorithm will increase the Traq OA Damper Min Position Request allowing more fresh air into the space. The OA CFM Deadband will be hard coded to +/- 250 CFM.

### Thermostat Notes

When the active unit mode is cool, one of the enthalpy or temperature methods are used to determine if economizer-based cooling should be enabled or disabled.

If the unit is applied with a thermostat, the algorithms use a fixed mixed air temperature setpoint of  $53^{\circ} \pm 3^{\circ}$  when the Y1 input is closed. If the unit is applied with a zone sensor, the algorithms use a dynamically calculated mixed air temperature setpoint, which is calculated by other algorithms, when cooling is requested.

The damper can be in four different states.

- **Closed** - The damper is held at 0%.
- **Minimum Position** - The damper is held at the minimum position as determined by the minimum position potentiometer on the ECA or RTEM by an edited input from ICS. This position is between 0% and 50%.

**Note:** When making minimum position adjustments, allow 30 to 45 seconds for actuator to respond.

- **Modulating** - Algorithms control the damper to meet cooling demand. When modulating, the damper's range of motion is between active minimum position and 100%.
- **Night Setback** - During NSTS, the damper drives to full closed position. If there is a call for cooling, the damper opens to satisfy the cooling requirement. The damper stays closed during heating mode.

During unoccupied mode, the minimum position is 0%.

### The following inputs are used:

#### Mixed Air Sensor (MAT)

MAT measures the dry bulb temperature of the air leaving the evaporator coil while economizing. Return air, outdoor air and cooling caused by any compressor cooling make up the mixed air input. The MAT is plugged into the economizer actuator module (ECA or RTEM).

#### Outdoor Air Sensor (OAT)

The OAT measures the ambient air surrounding the unit. It is located in the compressor section on the lower or upper left side for Precedent™ units depending on model, or the right side beneath the control panel on Voyager™ light commercial, or the economizer end of unit for Voyager™ commercial units. Ventilation holes in the access panel of the unit allow air movement across the sensor. The OAT connects to the RTRM module.

Figure 97. Outdoor air sensor

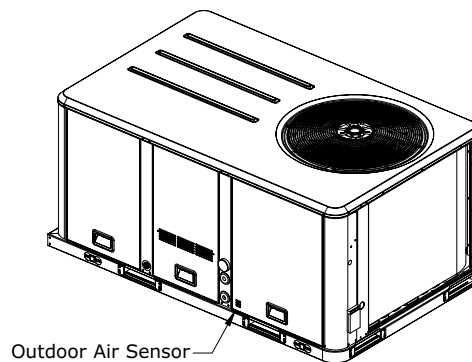

#### Outdoor Humidity Sensor (OAH)

The OAH measures the relative humidity of the outside air. It is located inside the economizer hood. The OAH is plugged into the ECA or RTEM.

#### Return Air Temperature Sensor (RAT)

The RAT measures the return air temperature. It is located on the return air damper of the economizer. The RAT is plugged into the ECA or RTEM.

### Return Humidity Sensor (RAH)

The RAH measures the relative humidity of the return air. It is located on the return air damper of the economizer. The RHS is plugged into the ECA or RTEM.

### Economizer Damper Enthalpy Layout

Table 105. Choice of enthalpy method

| Method used to determine economizer effectiveness | Required Data                             |
|---|---|
| Comparative Enthalpy                              | MAT, OAT, OAH, RAT, RAH                   |
| Reference Enthalpy                                | MAT, OAT, OAH                             |
| Reference Dry Bulb                                | MAT, OAT                                  |
| Unit will not economize                           | MAT or OAT data is invalid or unavailable |

Figure 98. Standard economizer - sensors locations

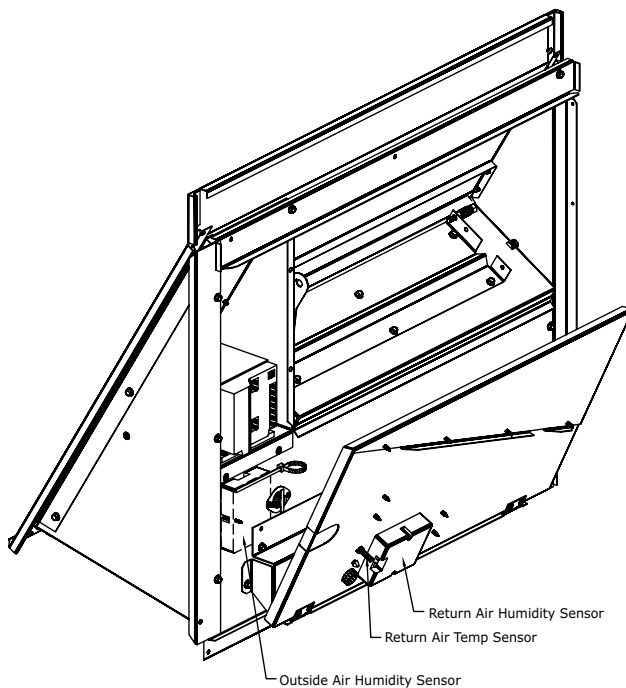
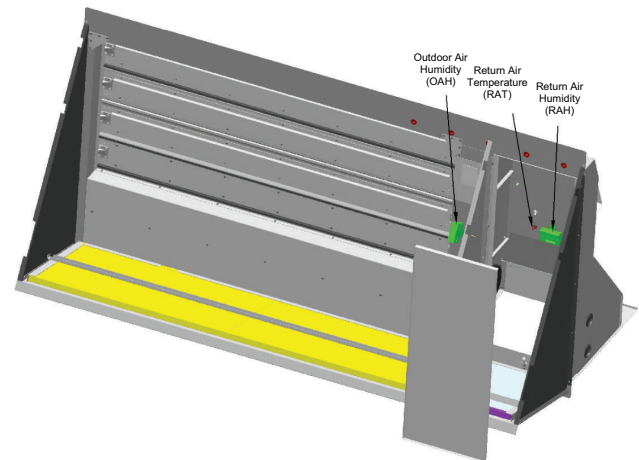

Figure 99. Low leak economizer (LLE) - sensor locations



### Economizer Operation Enthalpy Changeover

#### Dry Bulb/Reference Point Selections

The dry bulb or reference enthalpy point is user-selectable, according to the choices below. This selection is made on the ECA or RTEM.

Table 106. Potentiometer settings

| Potentiometer Setting Point | Dry bulb changeover Point | Reference Enthalpy |
|-----------------------------|---------------------------|--------------------|
| A                           | 73°F                      | 27 BTU/lb.         |
| B                           | 70°F                      | 25 BTU/lb.         |
| C <sup>(a)</sup>            | 67°F                      | 23 BTU/lb.         |
| D                           | 63°F                      | 22 BTU/lb.         |
| E                           | 55°F                      | 19 BTU/lb.         |

<sup>(a)</sup> Factory setting.

#### Comparative Enthalpy Method

OA enthalpy is compared with RA enthalpy.

- The economizer is enabled when OA Enthalpy less than RA Enthalpy - 3.0 BTU/lb.
- The economizer is disabled when OA Enthalpy greater than RA Enthalpy.
- While RA Enthalpy - 3.0 BTU/lb. less than OA Enthalpy less than RA Enthalpy, the economizer enable/disable status is not changed.

**Figure 100. Comparative enthalpy enable**

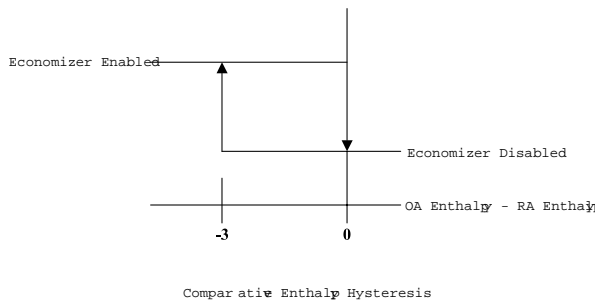

**Note:** If on a unit with comparative enthalpy control the OA or RA temp is greater than 120°F or less than 32°F, the economizer control will revert to reference enthalpy control if the OA temp is within 32°F and 120°F. If the unit is configured with comparative or reference enthalpy control, if the OA temp. is not within this range, the economizer control will revert to dry bulb control. Once this occurs, the "out of range" temperature (s) must fall to 118°F or rise to 34°F to again enable comparative or reference enthalpy control. If either OA or RA humidity is measured to be greater than 90% or less than 10%, the value of humidity which is reported by the RTEM and used for enthalpy calculation will be 90% or 10% respectively.

**Reference Enthalpy Method**

OA Enthalpy is compared with a reference enthalpy point.

- The economizer is enabled when OA Enthalpy less than reference enthalpy point - 0.5 BTU/lb.
- The economizer is disabled when OA Enthalpy greater than reference enthalpy point + 0.5 BTU/lb.
- While reference enthalpy point - 0.5 BTU/lb. less than OA Enthalpy less than reference enthalpy point + 0.5 BTU/lb. the economizer enable/disable status is not changed.

**Figure 101. Reference enthalpy enable**

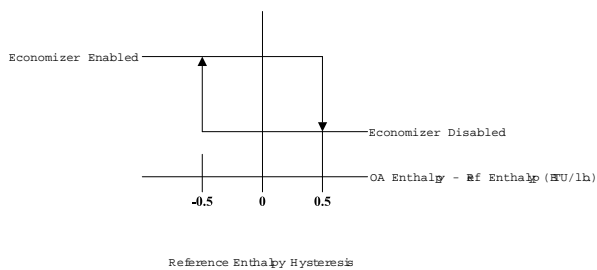

**Table 107. Internal calculations**

|   |   |
|---|---|
| Air enthalpy is a value calculated from the air temperature and relative humidity using the relationship: | <b>Enthalpy= 0.24 x O.A.Temp(deg. F) + h(R.H.,OAT)</b>  |
| Air enthalpy is calculated (Btu/lb. dry air) using:   | $H = 0.24 * T + W * Hv$<br>Where<br>T= dry bulb temperature, deg. F<br>W= humidity ration, lb. water/lb. dry air<br>$W = 0.622 * P / (14.696 - P)$<br>Hv= enthalpy of water at T, Btu/lb.<br>$Hv = 1062.1 + 0.43 * T$<br>Also,<br>P= partial pressure of water at T, psia<br>$P = (0.421 - 0.01503 * T + 0.000202 * T**2) * RH$ |

**Reference Dry Bulb Method**

OA temperature is compared with a reference dry bulb point.

- The economizer is enabled when OA Temp ≤ reference dry bulb point.
- The economizer is disabled when OA Temp ≥ (reference dry bulb point + 5.0)°F.
- While reference dry bulb point < OA Temp < (reference dry bulb point + 5.0°F), the economizer enable/disable status is not changed.

**Figure 102. Dry bulb enthalpy enable**

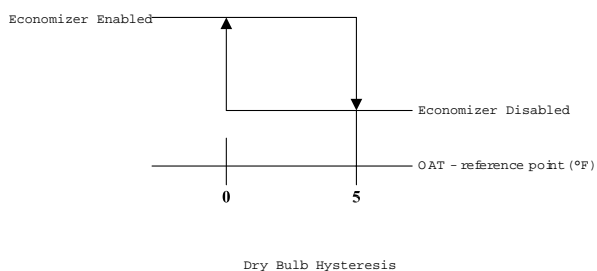

**ReliaTel™ Economizer Operation and Inputs**

**ReliaTel™ Economizer Inputs**

**Table 108. Terminals to read voltage**

|                   |                    |     |
|-------------------|--------------------|-----|
| Mixed Air Sensor  | ECA or RTEM Module | MAT |
| Return Air Sensor | ECA or RTEM Module | RAT |

**Note:** These are economizer inputs only. RTRM, RTOM inputs (zone temp, setpoints, OAT, DAT) are in the ReliaTel™ temperature inputs section.

The ECA module was upgraded August 1st, 2005 to widen the temperature range measured by the mixed air and return air sensor. As a result, the open DC voltage values measured at the ECA also changed. To determine which module you have, disconnect the sensor and measure the DC voltage at the MAT or RAT terminals on the ECA. The voltage reading for modules before August 1st, 2005 will read 2.50 Vdc. Modules for August 1st, 2005 and later will be 5.0 Vdc.

### Economizer Actuator Module W7340A1004 (used prior to 08/1/05)

Read DC voltage with the sensor attached. If voltage does not appear to be correct, read the resistance of the circuit, then the sensor itself, to see if a problem exists in the sensor or the wiring. With the sensor not attached there should be approximately 2.50 Vdc at the terminals listed above.

#### Service Tips

Terminal 1 in each of these circuits is common. All common terminals are grounded, therefore one volt meter lead can be attached to ground for voltage measurements.

**Table 109. W7340A1004 used before August 1st, 2005**

| Temp °F | Resistance (K ohms) | DC Volts |
|---------|---------------------|----------|
| 40      | 26.105              | 1.853    |
| 41      | 25.393              | 1.839    |
| 42      | 24.703              | 1.826    |
| 43      | 24.033              | 1.812    |
| 44      | 23.385              | 1.799    |
| 45      | 22.756              | 1.785    |
| 46      | 22.146              | 1.771    |
| 47      | 21.554              | 1.757    |
| 48      | 20.98               | 1.743    |
| 49      | 20.424              | 1.728    |
| 50      | 19.884              | 1.714    |
| 51      | 19.36               | 1.699    |
| 52      | 18.852              | 1.685    |
| 53      | 18.359              | 1.67     |
| 54      | 17.88               | 1.656    |
| 55      | 17.415              | 1.641    |
| 56      | 16.964              | 1.626    |
| 57      | 16.527              | 1.611    |
| 58      | 16.102              | 1.596    |
| 59      | 15.689              | 1.581    |
| 60      | 15.288              | 1.566    |
| 61      | 14.899              | 1.551    |
| 62      | 14.521              | 1.536    |
| 63      | 14.154              | 1.52     |
| 64      | 13.797              | 1.505    |
| 65      | 13.451              | 1.49     |
| 66      | 13.114              | 1.475    |
| 67      | 12.787              | 1.46     |
| 68      | 12.469              | 1.444    |
| 69      | 12.16               | 1.429    |
| 70      | 11.86               | 1.413    |
| 71      | 11.568              | 1.398    |
| 72      | 11.284              | 1.383    |
| 73      | 11.008              | 1.367    |
| 74      | 10.74               | 1.352    |
| 75      | 10.479              | 1.337    |
| 76      | 10.225              | 1.321    |
| 77      | 9.978               | 1.306    |
| 78      | 9.738               | 1.291    |
| 79      | 9.505               | 1.276    |
| 80      | 9.278               | 1.261    |

### Economizer Actuator Module W7340B1002 (08/01/05 and later)

Read DC voltage with the sensor attached. If voltage does not appear to be correct, read the resistance of the circuit, then the sensor itself, to see if a problem exists in the sensor or the wiring. With the sensor not attached there should be approximately 5.0 Vdc at the terminals listed above.

**Table 110. W7340B1002 used August 1, 2005 and later**

| Temp °F | Resistance (K Ohms) | DC Volts |
|---------|---------------------|----------|
| 10      | 63.577              | 4.317    |
| 11      | 61.624              | 4.299    |
| 12      | 59.737              | 4.28     |
| 13      | 57.913              | 4.261    |
| 14      | 56.153              | 4.241    |
| 15      | 54.452              | 4.221    |
| 16      | 52.807              | 4.201    |
| 17      | 51.216              | 4.18     |
| 18      | 49.677              | 4.159    |
| 19      | 48.188              | 4.138    |
| 20      | 46.748              | 4.116    |
| 21      | 45.354              | 4.094    |
| 22      | 44.007              | 4.072    |
| 23      | 42.705              | 4.049    |
| 24      | 41.446              | 4.026    |
| 25      | 40.226              | 4.002    |
| 26      | 39.046              | 3.978    |
| 27      | 37.904              | 3.954    |
| 28      | 36.797              | 3.929    |
| 29      | 35.726              | 3.904    |
| 30      | 34.689              | 3.879    |
| 31      | 33.686              | 3.853    |
| 32      | 32.72               | 3.827    |
| 33      | 31.797              | 3.801    |
| 34      | 30.903              | 3.775    |
| 35      | 30.037              | 3.749    |
| 36      | 29.198              | 3.722    |
| 37      | 28.386              | 3.695    |
| 38      | 27.599              | 3.668    |
| 39      | 26.836              | 3.641    |
| 40      | 26.097              | 3.613    |
| 41      | 25.383              | 3.585    |
| 42      | 24.69               | 3.557    |
| 43      | 24.018              | 3.528    |
| 44      | 23.367              | 3.5      |
| 45      | 22.736              | 3.471    |
| 46      | 22.123              | 3.442    |
| 47      | 21.53               | 3.412    |
| 48      | 20.953              | 3.383    |
| 49      | 20.396              | 3.353    |
| 50      | 19.854              | 3.324    |
| 51      | 19.33               | 3.294    |
| 52      | 18.821              | 3.264    |
| 53      | 18.327              | 3.233    |
| 54      | 17.847              | 3.203    |
| 55      | 17.382              | 3.173    |
| 56      | 16.93               | 3.142    |
| 57      | 16.491              | 3.111    |
| 58      | 16.066              | 3.08     |
| 59      | 15.654              | 3.05     |
| 60      | 15.253              | 3.019    |
| 61      | 14.864              | 2.988    |

**Table 110. W7340B1002 used August 1, 2005 and later (continued)**

| Temp °F | Resistance (K Ohms) | DC Volts |
|---------|---------------------|----------|
| 62      | 14.486              | 2.957    |
| 63      | 14.119              | 2.926    |
| 64      | 13.762              | 2.895    |
| 65      | 13.416              | 2.864    |
| 66      | 13.078              | 2.832    |
| 67      | 12.752              | 2.801    |
| 68      | 12.435              | 2.77     |
| 69      | 12.126              | 2.739    |
| 70      | 11.827              | 2.708    |
| 71      | 11.535              | 2.677    |
| 72      | 11.252              | 2.646    |
| 73      | 10.977              | 2.616    |
| 74      | 10.709              | 2.585    |
| 75      | 10.448              | 2.554    |
| 76      | 10.194              | 2.523    |
| 77      | 9.949               | 2.493    |
| 78      | 9.71                | 2.462    |
| 79      | 9.477               | 2.432    |
| 80      | 9.25                | 2.402    |
| 81      | 9.03                | 2.372    |
| 82      | 8.815               | 2.342    |
| 83      | 8.607               | 2.312    |
| 84      | 8.404               | 2.283    |
| 85      | 8.206               | 2.253    |
| 86      | 8.014               | 2.224    |
| 87      | 7.827               | 2.195    |
| 88      | 7.645               | 2.166    |
| 89      | 7.468               | 2.137    |
| 90      | 7.295               | 2.109    |
| 91      | 7.127               | 2.08     |
| 92      | 6.963               | 2.052    |
| 93      | 6.803               | 2.024    |
| 94      | 6.648               | 1.996    |
| 95      | 6.497               | 1.969    |
| 96      | 6.35                | 1.942    |
| 97      | 6.207               | 1.915    |
| 98      | 6.067               | 1.888    |
| 99      | 5.931               | 1.861    |
| 100     | 5.798               | 1.835    |
| 101     | 5.668               | 1.809    |
| 102     | 5.543               | 1.783    |
| 103     | 5.42                | 1.757    |
| 104     | 5.3                 | 1.732    |
| 105     | 5.184               | 1.707    |
| 106     | 5.07                | 1.682    |
| 107     | 4.959               | 1.658    |
| 108     | 4.851               | 1.633    |
| 109     | 4.745               | 1.609    |
| 110     | 4.642               | 1.585    |
| 111     | 4.542               | 1.562    |
| 112     | 4.444               | 1.539    |
| 113     | 4.349               | 1.516    |
| 114     | 4.256               | 1.493    |
| 115     | 4.165               | 1.47     |
| 116     | 4.076               | 1.448    |
| 117     | 3.99                | 1.426    |
| 118     | 3.906               | 1.405    |
| 119     | 3.824               | 1.383    |
| 120     | 3.743               | 1.362    |

**ReliaTel™ Economizer Control Actuator (ECA or RTEM) (LED Fault Code Info.)**

*Note: Honeywell Actuator (Obsolete - Not Available to Order)*

An actuator fault will occur when the economizer position signal to the actuator is 25% different than the feedback signal from the actuator.

*Note: If the economizer is not attached to the motor, you will get an actuator fault only after the economizer would tell the motor to drive to at least 25% open.*

**Actuator Fault (RTEM)**

An actuator fault will occur when the economizer position signal to the actuator is 10% different than the feedback signal from the actuator for 4 continuous minutes.

*Note: If the economizer is not attached to the motor, you would get an actuator fault only after the economizer would tell the motor to drive to at least 10% open for at least 4 minutes.*

**Sensor Faults**

A sensor fault will occur if a sensor fails during normal operation. When power is freshly applied to the unit, the ECA and RTEM recognize which sensors are installed.

*Note: If only the MAT is hooked up, the economizer control action will be dry bulb. If the OAH/OAT and MAT are hooked up, the economizer control action will be in reference enthalpy.*

If after power up one of the connected sensors is disconnected, the economizer should indicate a fault.

*Note: The actuator has an internal potentiometer that reports the actual damper position. Should the linkage become bound, the actuator may report an unexpected output to a BAS output (Tracer®, Tracker®, CCP).*

The mixed air sensor (MAT) and outdoor air sensor (OAT) input from the RTRM are minimum required sensors.

If a CO<sub>2</sub> sensor is not hooked up, the economizer will not look for it and will not fault.

The flash codes are prioritized. The higher the flash count, the more priority the fault has. If there is more than one fault, only the higher priority fault will flash.

The green system LED is located near the center of the Honeywell ECA Module and in the corner of the RTEM.

**Table 111. Economizer module flash codes**

|  |   |
|--|---|
| On                                     | OK to economize                                 |
| Slow flash (½ second on, ¼ second off) | Not OK to economize                             |
| ¼ second on, 2 seconds off             | No communication                                |
| Off                                    | No power or system failure                      |
| Error codes                            | ½ second on, ¼ second off, 2 second final flash |

**Table 111. Economizer module flash codes (continued)**

|   |  |
|---|--|
| 1 flash (2 seconds on, ¼ second off)                      | Actuator fault   |
| 2 flash   | CO <sub>2</sub> sensor   |
| 3 flash   | RAH humidity sensor  |
| 4 flash   | RAT temp sensor  |
| 6 flash   | OAH humidity sensor  |
| 7 flash   | No communication with RTRM at power-up, loss of communication with RTRM, or no reading from the outdoor air sensor (OAT) in the condenser section. |
| 8 flash   | MAT temp sensor (Active with Motorized Damper)   |
| 9-11 flash  | Internal fault (Honeywell only - obsolete; not available to order)   |
| Modbus communication voltage when measured at ECA or RTEM | J17-1 and J17-2 (MBUS +/-) will read approximately 0.5 - 2.0 VDC (flashing)  |

## Electromechanical Economizer

*Note: Obsolete - Not available to order.*

**Figure 103. Economizer actuator (ECA) connected to the unit**

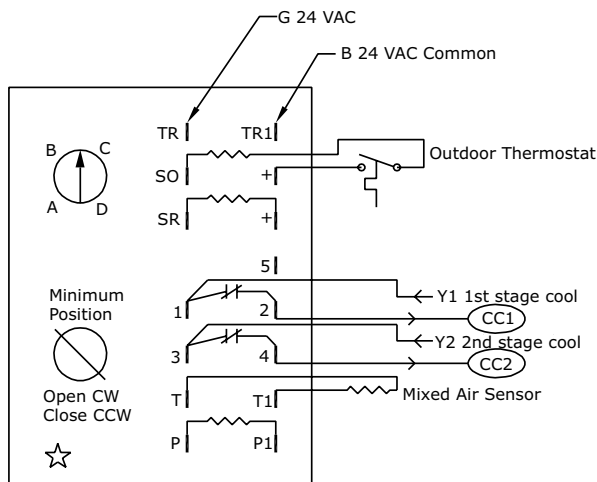

**Figure 104. Economizer actuator (ECA) connected to the unit**

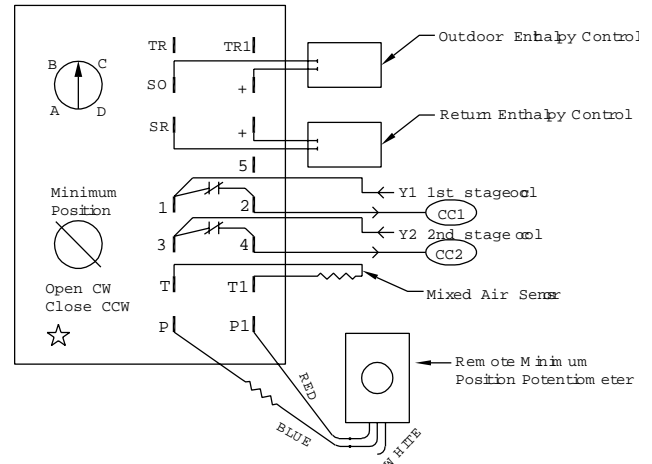

## Electromechanical Economizer Testing

*Note: Obsolete - Honeywell only.*

### Electromechanical Mixed Air Sensor

When the outdoor air thermostat is in the cold position (closed), the unit will attempt to economize if a fan (G) and cooling (Y1) call exists at the ECA module. This is readily apparent at the ECA, as the ok to economize LED will be on. During this time, the ECA is measuring the mixed air temperature via the mixed air sensor (MAS).

### Service Tips

- The MAS sensor is not energized unless the LED is on (G signal present, OK to economize), and the Y1 signal is present.
- If the MAS is open, approximately 4.3 Vdc will be seen.
- Outdoor Air Thermostat opens at 70°F and closes at 60°F.
- Read the voltage with the sensor connected, read the resistance with the sensor disconnected.

**Table 112. Temperature input**

| Temp F | Temp C | R(K OHMS) | DC Volts |
|--------|--------|-----------|----------|
| 33.8   | 1      | 9.576     | 3.91     |
| 35.6   | 2      | 9.092     | 3.882    |
| 37.4   | 3      | 8.636     | 3.894    |
| 39.2   | 4      | 8.204     | 3.863    |
| 41     | 5      | 7.796     | 3.829    |
| 42.8   | 6      | 7.412     | 3.79     |
| 44.6   | 7      | 7.048     | 3.749    |
| 46.4   | 8      | 6.705     | 3.713    |
| 48.2   | 9      | 6.38      | 3.674    |
| 50     | 10     | 6.073     | 3.634    |
| 51.8   | 11     | 5.782     | 3.59     |
| 53.6   | 12     | 5.507     | 3.55     |
| 55.4   | 13     | 5.247     | 3.507    |
| 57.2   | 14     | 5         | 3.42     |
| 59     | 15     | 4.767     | 3.373    |
| 60.8   | 16     | 4.545     | 3.328    |

**Table 112. Temperature input (continued)**

| Temp F | Temp C | R(K OHMS) | DC Volts |
|--------|--------|-----------|----------|
| 62.6   | 17     | 4.335     | 3.283    |
| 64.4   | 18     | 4.136     | 3.239    |
| 66.2   | 19     | 3.948     | 3.18     |
| 68     | 20     | 3.769     | 3.157    |
| 69.8   | 21     | 3.599     | 3.118    |
| 71.6   | 22     | 3.437     | 3.08     |
| 73.4   | 23     | 3.284     | 3.034    |
| 75.2   | 24     | 3.138     | 3.007    |
| 77     | 25     | 3         | 2.971    |
| 78.8   | 26     | 2.869     | 2.932    |
| 80.6   | 27     | 2.744     | 2.896    |
| 82.4   | 28     | 2.625     | 2.86     |
| 84.2   | 29     | 2.512     | 2.824    |
| 86     | 30     | 2.404     | 2.787    |
| 87.8   | 31     | 2.301     | 2.75     |
| 89.6   | 32     | 2.204     | 2.714    |
| 91.4   | 33     | 2.111     | 2.676    |
| 93.2   | 34     | 2.023     | 2.639    |
| 95     | 35     | 1.938     | 2.6      |
| 96.8   | 36     | 1.858     | 2.561    |
| 98.6   | 37     | 1.781     | 2.526    |
| 100.4  | 38     | 1.708     | 2.484    |

**Note:** Obsolete - not available to order - Honeywell Electromechanical

### Three Position Damper

**Note:** Obsolete - Honeywell only

Full open economizer minimum position is accomplished by setting the ECA 50% minimum position potentiometer to

100% and installing a set of contacts in series with the existing 130 ohm resistor to terminals P and P1 on the ECA.

Any intermediate (0 - 50%) economizer position is accomplished by installing a 0 - 270 ohm potentiometer in series with an additional set of contacts and the existing 130 ohm resistor to terminals P and P1 on the ECA. 0 ohms = 50% outside air and 270 ohms = 0% outside air.

Fully closed position is accomplished when the indoor fan is disabled.

**Note:** Actual outside airflow is also dependent on return air static pressure.

**Figure 105. Electromechanical economizer - three position damper**

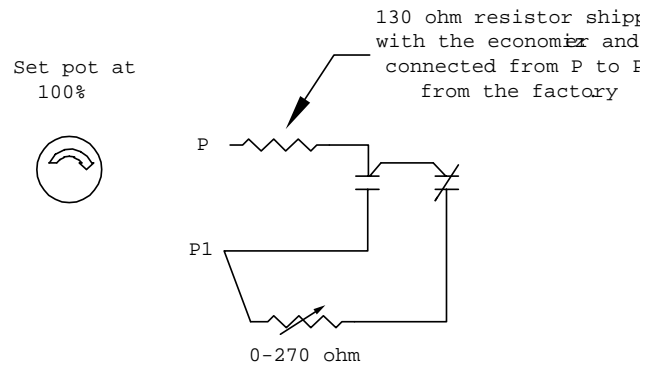



# Electromechanical Units

## Time Delay Relay

This time delay circuit board attaches to the side of the relay. When energized, the fan starts immediately and when de-energized shuts off 80 seconds later. This delay is not adjustable.

Figure 106. Time delay relay

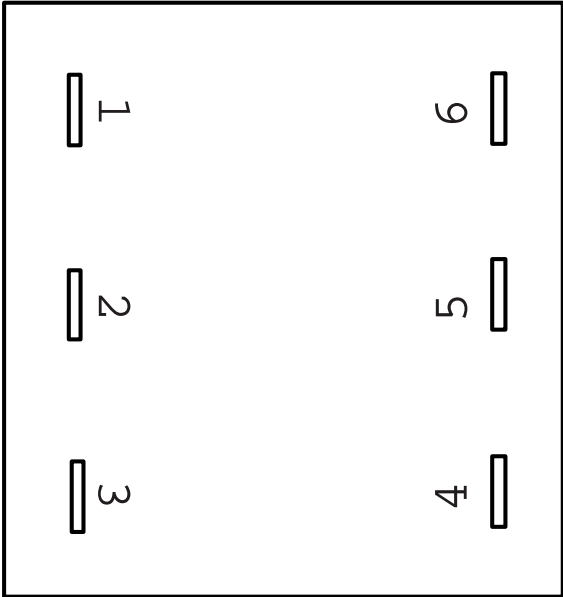

## Fan Off Delay Solid State Timer

When **G** is energized, the N.O. contacts between 1 and 2 close immediately, energizing the fan relay (**F**), which in turn starts the indoor fan. When **G** is deenergized, the contacts between 1 and 2 remain closed for 80 seconds, then open. This in turn de-energizes the **F** relay, which stops the indoor fan.

Figure 107. Electromechanical time delay solid state

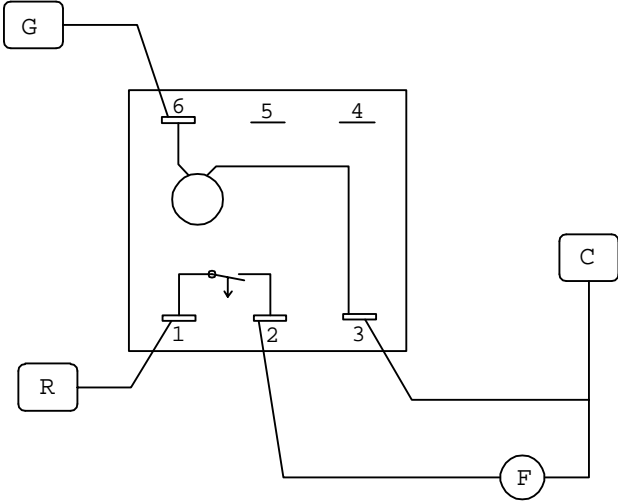

# ReliaTel™ - Humidity Sensors

## Outdoor Humidity Sensor

Field installed accessory, located below and to the left of economizer actuator motor. Used in reference (BAYENTH005\*) and comparative (BAYENTH006\*) enthalpy control. Operates from 10-90% RH, 32°F – 90°F.

**Figure 108. Humidity sensor**

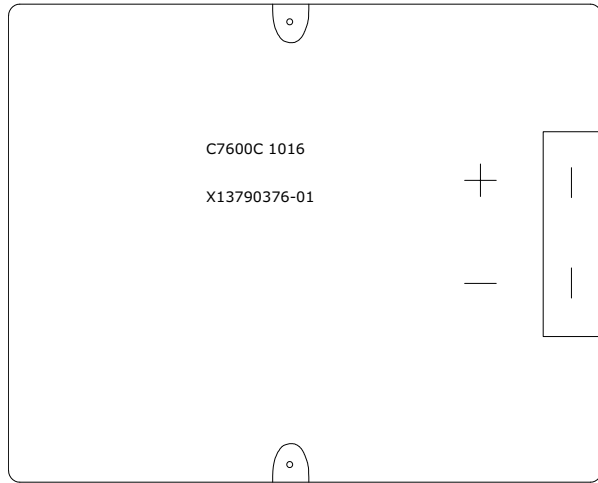

Component Description  
Humidity Sensor (OAH, RAH)

Part Number  
SEN-01036

## Return Humidity Sensor

Field installed accessory, located inside economizer barometric relief hood. Used in comparative (BAYENTH006\*) enthalpy control only. (Honeywell #C7600C).

## To Test Humidity Sensors

| Return Air Humidity Sensor | ECA<br>or<br>RTEM | RAH/RAE |
|----------------------------|-------------------|---------|
| Outdoor Humidity Sensor    | ECA<br>or<br>RTEM | OAH/OAE |

To test this circuit, place a DC milliamp meter in series with either of the leads to the humidity sensor. If the reading is 0ma, polarity may be reversed. Reverse + & - and retest. If the reading does not correspond to the table below, check the output voltage from the ECA or RTEM with the sensor disconnected.

The DC voltage at the OAH and RAH pins on the Honeywell ECA module should be approximately 15 or 20 Vdc (depending on the ECA or RTEM version) or 23 Vdc if the module is a RTEM. If so, and all connections are intact, replace the sensor. If the appropriate Vdc signal is not

present, yet the economizer module's green LED is on, the economizer module has failed.

**Table 113. Module voltage compared to return humidity**

| RH%  | DCma   |
|------|--------|
| 100% | 20     |
| 97.7 | 19.636 |
| 95.5 | 19.286 |
| 93.4 | 18.947 |
| 91.4 | 18.621 |
| 89.4 | 18.305 |
| 87.5 | 18     |
| 85.7 | 17.705 |
| 83.9 | 17.419 |
| 82.1 | 17.143 |
| 80.5 | 16.875 |
| 78.8 | 16.615 |
| 77.3 | 16.364 |
| 75.7 | 16.119 |
| 74.3 | 15.882 |
| 72.8 | 15.652 |
| 71.4 | 15.429 |
| 70.1 | 15.211 |
| 68.8 | 15     |
| 67.5 | 14.795 |
| 66.2 | 14.595 |
| 65   | 14.4   |
| 63.8 | 14.211 |
| 62.7 | 14.026 |
| 61.5 | 13.846 |
| 60.4 | 13.671 |
| 59.4 | 13.5   |
| 58.3 | 13.333 |
| 57.3 | 13.171 |
| 56.3 | 13.012 |
| 55.4 | 12.857 |
| 54.4 | 12.706 |
| 53.5 | 12.558 |
| 52.6 | 12.414 |
| 51.7 | 12.273 |
| 50.8 | 12.135 |
| 50   | 12     |
| 49.2 | 11.868 |
| 48.4 | 11.739 |
| 47.6 | 11.613 |
| 46.8 | 11.489 |
| 46.1 | 11.368 |
| 45.3 | 11.25  |
| 44.6 | 11.134 |
| 43.9 | 11.02  |
| 43.2 | 10.909 |
| 42.5 | 10.8   |
| 41.8 | 10.693 |
| 41.2 | 10.588 |
| 40.5 | 10.485 |
| 39.9 | 10.385 |
| 39.3 | 10.286 |
| 38.7 | 10.189 |
| 38.1 | 10.093 |
| 37.5 | 10     |
| 36.9 | 9.908  |

**Table 113. Module voltage compared to return humidity (continued)**

| RH%  | DCma  |
|------|-------|
| 36.4 | 9.818 |
| 35.8 | 9.73  |
| 35.3 | 9.463 |
| 34.7 | 9.558 |
| 34.2 | 9.474 |
| 33.7 | 9.391 |
| 33.2 | 9.31  |
| 32.7 | 9.231 |
| 32.2 | 9.153 |
| 31.7 | 9.076 |
| 31.2 | 9     |
| 30.8 | 8.926 |
| 30.3 | 8.852 |
| 29.9 | 8.78  |
| 29.4 | 8.71  |
| 29   | 8.64  |
| 28.6 | 8.571 |
| 28.1 | 8.504 |
| 27.7 | 8.438 |
| 27.3 | 8.372 |
| 26.9 | 8.308 |
| 26.5 | 8.244 |
| 26.1 | 8.182 |
| 25.8 | 8.12  |
| 25.4 | 8.06  |
| 25   | 8     |

**Table 113. Module voltage compared to return humidity (continued)**

| RH%  | DCma  |
|------|-------|
| 24.6 | 7.941 |
| 24.3 | 7.833 |
| 23.9 | 7.826 |
| 23.6 | 7.77  |
| 23.2 | 7.714 |
| 22.9 | 7.66  |
| 22.5 | 7.606 |
| 22.2 | 7.552 |
| 21.9 | 7.5   |
| 21.6 | 7.448 |
| 21.2 | 7.397 |
| 20.9 | 7.347 |
| 20.6 | 7.297 |
| 20.3 | 7.248 |
| 20   | 7.2   |

### ECA Module Voltages

W7340A1004 (Production part prior to 8/1/2005) - 20.0 Vdc

W7340B1002 (Production part since 8/1/2005) - 15.0 Vdc

### RTEM Module Voltage

MOD03099 - 23 Vdc

# ReliaTel™ - Supply Air Tempering Control

Supply air tempering maintains the supply air temperature above a lower limit during minimum ventilation periods when in heat mode on a CV unit and during inactive cool mode on a VAV unit. Supply air tempering is available when using a BAYSENS019\*/AYSTAT666\* programmable zone sensor, BAYSENS006-11/AYSTAT661-664 mechanical zone sensor, or Trane ICS system.

The unit requires an RTOM (options module) and BAYTUBE discharge air sensing kit. Supply air tempering will not work with a conventional thermostat.

## Enable Supply Air Tempering

### Mechanical Zone Sensor BAYSENS006-11/AYSTAT661-664

Remove the jumper from RTOM J3-1 and J3-2.

### Programmable Zone Sensor BAYSENS019\*/AYSTAT666\*

Change Option 4 in the options menu to 1=enabled. Or, remove the jumper from RTOM J3-1 and J3-2.

### COMM 3/4 (TCI)

Enable through appropriate menu. Supply air tempering can also be enabled by removing the jumper from RTOM J3-1 and J3-2.

### LonTalk® (LCI)

Enable through nciPersonality2. This function may not be available with some 3rd party systems. Supply air tempering can also be enabled by removing the jumper from RTOM J3-1 and J3-2.

### Voyager™ 27.5 to 50 tons VAV with Staged Heat

Supply air tempering is not available. The RTOM J3-1 and J3-2 jumper is ignored.

## Sequence of Operation

### Constant Volume Units with Staged Heat

When supply air tempering is enabled, the fan mode is on, active mode is heat or emergency heat, and with the unit not actively heating. Stage 1 of heat is turned ON when the supply air temperature is 10°F below the active heating setpoint.

Stage 1 of heat is turned OFF when the supply air temperature is 10°F above the active heating setpoint or the mode is no longer heat or emergency heat. Should the zone temperature exceed the active heating setpoint by 1-2F, supply air tempering will cease until another normal heating cycle resumes.

For heat pump units, the auxiliary heat is used for tempering.

*Note: Tempering on CV units with modulating heat is inherent to the modulating heat control design.*

### Variable Air Volume Units

For VAV units configured with a modulating heat type if the unit is operating in occupied supply air cooling mode, but the unit is not actively cooling, the unit will energize and modulate the modulating heat output to prevent the supply air from falling below the SA cool setpoint deadband low end (SACSP – 3.5°F) once the unit has de-energized all mechanical cooling (if energized). Upon satisfying the SA tempering requirements a five-minute SA tempering delay timer will start whenever the modulating heat is commanded to 0%. This timer will be reset to 5 minutes whenever there is an active call for heat to meet SA tempering demands.

Tempering will be discontinued whenever the five-minute SA tempering delay timer has timed-out and there is an active cooling request from the VAV occupied mechanical cooling function.

# TCl Comm 3/4

## Discharge Air Sensing

Units connected to ICS systems have the ability to look at discharge air temperature. Units using COMM3/4 only have the ability to see one point for discharge air temperature and that is through the mixed air sensor input on the ECA or RTEM module labeled MAT. This input is reported back to the ICS display graphics as SAS (supply air sensor). The discharge air sensor is used for supply air tempering with an ICS system or a BAYSENS119\* or previous version BAYSENS019\* programmable zone sensor.

Systems using LonTalk® and LCI have the ability to see both mixed air and discharge air temperature.

The following discussion is focused only on units utilizing COMM3/4 communications.

If an economizer is not installed, the discharge air sensor option is required to monitor discharge air temperature. The sensor must be used in conjunction with the RTOM module (optional on 3 to 25 ton units). The discharge sensor will be located in the discharge opening of the unit.

### 3 to 25 Tons Units

If a unit has an economizer, in order to monitor true discharge air temperature, the unit can use the mixed air sensor, but it will have to be relocated to the discharge of the unit. If the mixed air sensor is relocated to the discharge of the unit, no further action is required. The sensor will report back true discharge temperature through

the economizer module, and also still function as the mixed air sensor for the economizer operation. The discharge air sensor option is the recommended method because it uses an averaging tube to sense the air across the discharge opening. This sensor will have to be wired back to the mixed air sensor (MAT) input on the economizer module and replaces the MAT sensor.

**Note:** *If the unit has an economizer and the discharge air sensor option is installed, then a 5.6K (1/4 watt) resistor must be installed on the OAT terminals of the economizer actuator module (ECA). This resistor will allow the economizer to continue operation from the mixed air sensor. The discharge air sensor will report true discharge temperature to the RTOM, and in turn, to the ICS panel via the TCI COMM3/4 communications. KIT08318 can be ordered for the 5.6K resistor.*

### 27.5 to 50 Tons Units

The discharge air sensor is standard on VAV units, but is optional on CV units.

#### Service Note

Should there be a failure of either the mixed air sensor or the discharge air sensor, the diagnostic will be reported back as a supply air sensor failure. It will require a visit to the job site to determine which sensor has failed.

# ReliaTel™ Ventilation Override

Three ventilation modes are available with ReliaTel™ through use of an options module (RTOM) and economizer (ECA or RTEM) with power exhaust. Following is a list of each mode and what happens during each. Connections to the unit to accomplish ventilation modes are shown below. All three inputs are shown for illustration but only one is typically used.

**Note:** Although not associated with ventilation override, Humidistat connections for dehumidification are also provided on this terminal block.

Emergency shutdown from the LTBI 5&6 will override any ventilation override mode. Ventilation override inputs override smoke detector inputs through the RTOM. (3 to 25 tons only).

**Table 114. Ventilation modes**

| Supply Fan Forced |     | IGV/VFD <sup>(a)</sup> | Compressors ay run? | OK to heat (gas/elec)? | Economizer position? | Power Exhaust? | Exhaust Damper <sup>(b)</sup> | VHR Relay <sup>(a)</sup> |
|-------------------|-----|------------------------|---------------------|------------------------|----------------------|----------------|-------------------------------|--------------------------|
| Pressurization    | ON  | 100%                   | No                  | No                     | 100%                 | Off            | 0%                            | ON                       |
| Purge             | ON  | 100%                   | No                  | No                     | 100%                 | On             | 100%                          | ON                       |
| Exhaust           | OFF | 100%                   | No                  | No                     | 0%                   | On             | 100%                          | ON                       |

<sup>(a)</sup> Voyager 27.5 to 50 tons VAV

<sup>(b)</sup> Exhaust damper is controlled on units with power exhaust with statitrac.

**Figure 109. Low voltage terminal strip**

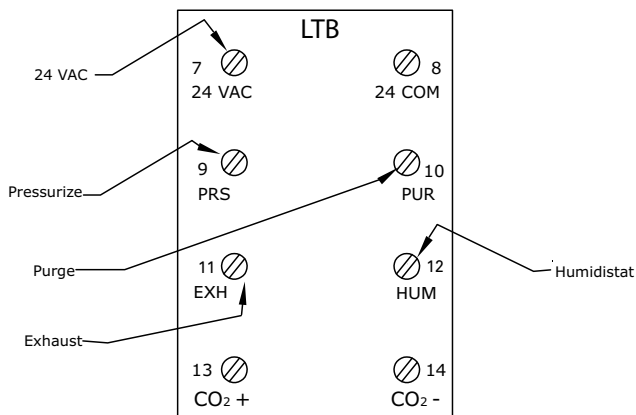

# Demand Control Ventilation (DCV)

## CO<sub>2</sub> Sensor Connections

Demand controlled ventilation (DCV) describes a control strategy that responds to the actual demand (need) for ventilation by regulating the rate at which the HVAC system brings outdoor air into the building. There are several ways to assess ventilation demand:

- Occupancy sensors, which detect the presence or number of people in each monitored space.
- Occupancy schedules, which allow a building automation system to predict the current population based on the time of day.
- Carbon dioxide (CO<sub>2</sub>) sensors, which monitor the concentration of CO<sub>2</sub> that the occupants continuously produce.

Regardless of which method is used, DCV strategies vary the outdoor air intake in response to the current population. The practice of using carbon dioxide concentration as an indicator of population or ventilation rate is often called CO<sub>2</sub> based, demand-controlled ventilation.

The CO<sub>2</sub> DCV function is only available for units with economizers; the 50% motorized damper option will not operate with a CO<sub>2</sub> sensor. The 50% motorized damper opens to one position and does not modulate like the economizer. The 50% damper does not come with a return blade or a mixed air sensor.

The CO<sub>2</sub> option does not require an RTOM (3 to 25 tons) board.

The CO<sub>2</sub> sensor can be configured for 0-10 Vdc, 0-20 ma, or 4-20 mA analog outputs. For use with the ReliaTel™ economizer, the sensor must be set for 0-10 Vdc. As the CO<sub>2</sub> level increases, the voltage output increases accordingly.

The potentiometers used for setting the CO<sub>2</sub> setpoints and outdoor air damper position setpoints are located on the ReliaTel™ RTEM module.

**Table 115. CO<sub>2</sub> levels and associated voltage outputs**

| CO <sub>2</sub> Level (ppm) | Voltage Output (VDC) |
|-----------------------------|----------------------|
| 0                           | 0                    |
| 200                         | 1                    |
| 400                         | 2                    |
| 600                         | 3                    |
| 800                         | 4                    |
| 1000                        | 5                    |
| 1200                        | 6                    |
| 1400                        | 7                    |
| 1600                        | 8                    |
| 1800                        | 9                    |
| 2000                        | 10                   |

## Using Multiple CO<sub>2</sub> Sensors to Monitor more than One Location

There may be circumstances where it is desirable to use multiple zone CO<sub>2</sub> sensor monitoring and control. With ReliaTel controls, this is possible by wiring up to five sensors in parallel. It should be understood, this is not the same as CO<sub>2</sub> averaging. With up to five sensors connected, the sensor with the highest signal will take priority. CO<sub>2</sub> sensor averaging is not possible.

Because there is only one input connection on the economizer ECA module, it is acceptable to wire sensors back to unit in a parallel or star configuration, but wiring will have to be spliced at an appropriate location to accommodate one point connection to the ECA module.

Units with the 50% motorized damper option are not designed to operate with a CO<sub>2</sub> sensor. However, with a minor modification, the 50% damper option will operate, but will have limited outside airflow. Because there is no return air damper installed, only about 40 to 50% of total cfm can be obtained through the outside air damper; but depending on the application, this may be acceptable to satisfy a CO<sub>2</sub> requirement.

To use a CO<sub>2</sub> sensor with a 50% motorized damper, it will be necessary to apply a 22K ohm (1/4 watt) resistor to the MAT (mixed air temperature) input on the economizer ECA module.

1. Locate the wiring in the fan compartment where the mixed air sensor would normally be wire.
2. Cut the spade connectors off ends of the wires.
3. Using appropriate splice caps, splice the 22K resistor to the wires.
4. Secure wires to prevent damage from sharp edges.

Wire length runs for sensors should follow the guidelines per [Table 116, p. 163](#).

**Table 116. Wire length**

| Distance from Unit to Control | Recommended Wire Size |
|-------------------------------|-----------------------|
| 0 - 150 feet                  | 22 gauge              |
| 0 - 45.7 m                    | 0.33 mm <sup>2</sup>  |
| 151 - 240 feet                | 20 gauge              |
| 46 - 73.1 m                   | 0.50 mm <sup>2</sup>  |
| 241 - 385 feet                | 18 gauge              |
| 73.5 - 117.3 m                | 0.75 mm <sup>2</sup>  |
| 386 - 610 feet                | 16 gauge              |
| 117.7 - 185.9 m               | 1.3 mm <sup>2</sup>   |
| 611 - 970 feet                | 14 gauge              |
| 186.2 - 295.7 m               | 2.0 mm <sup>2</sup>   |

## How to Wire in Multiple CO<sub>2</sub> sensors – ReliaTel

Multiple CO<sub>2</sub> sensors can be wired together. This method will control to the highest CO<sub>2</sub> zone. It is not CO<sub>2</sub> averaging.

**Figure 110. Wiring multiple CO<sub>2</sub> — parallel or star configuration**

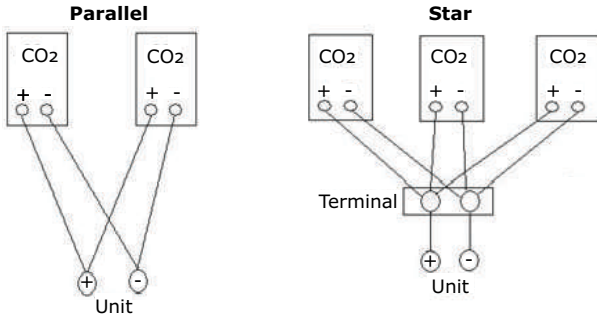

## RTEM Operation

Units equipped with an RTEM economizer logic module will perform demand controlled ventilation differently based on the RTRM version also installed in the unit. See below for information concerning the different configurations of RTEM and RTRM versions.

### RTEM with RTRM v8.0 and Later

For units equipped with an RTRM v8.0 or later and also an RTEM, the control will utilize two separate space CO<sub>2</sub> setpoints and two separate damper minimum position setpoints as described below:

### CO<sub>2</sub> Setpoints

The CO<sub>2</sub> setpoints will be obtained through two onboard potentiometers located on the RTEM, building design CO<sub>2</sub> setpoint (upper limit) and DCV minimum CO<sub>2</sub> setpoint (lower limit). The upper limit CO<sub>2</sub> setpoint will have a range of 1000-2000 ppm and the lower limit CO<sub>2</sub> setpoint will have a range of 300-1900 ppm. A 100 ppm differential will be enforced between the upper limit CO<sub>2</sub> setpoint and lower limit CO<sub>2</sub> setpoint. In the case of the lower limit CO<sub>2</sub> setpoint being set to compromise this 100 ppm differential, the upper limit CO<sub>2</sub> setpoint will not be pushed and the 100 ppm differential will be enforced. However, if the upper limit CO<sub>2</sub> setpoint is set to compromise the 100 ppm differential, the lower limit CO<sub>2</sub> setpoint will be pushed down in order to enforce the 100 ppm differential and to allow the upper limit CO<sub>2</sub> setpoint to be set as desired.

### OA Damper Min Position Setpoints

The OA damper min position setpoints will be determined by the position of two onboard potentiometers located on the RTEM; building design min position setpoint (10-50%) and DCV min position setpoint (0-40%). A 10% differential will be enforced between the design min position setpoint and DCV min position setpoint; the DCV min position setpoint will always be 10% less than the design min

position setpoint. If the unit is configured for DCV and a remote min position value is present on the P0 and P1 terminals, the remote min position will become the design min position setpoint and the 10% differential will not be enforced. If the remote min position is set to be lower than the DCV min position setpoint, the remote min position setpoint will be used for the design min position and the DCV min position.

## Sequence of Operation

When the unit is in the occupied mode, the outdoor-air (OA) damper opens to the DCV minimum position setpoint. If the space CO<sub>2</sub> level is less than or equal to the lower limit CO<sub>2</sub> setpoint, the OA damper will close to the DCV minimum position setpoint. If the space CO<sub>2</sub> level is greater than or equal to the upper level CO<sub>2</sub> setpoint, the OA damper will open to the design minimum position setpoint. If the space CO<sub>2</sub> level is greater than the lower limit CO<sub>2</sub> setpoint and less than the upper limit CO<sub>2</sub> setpoint, the OA damper position is modulated proportionally between the DCV minimum and the design minimum position setpoints. If there is a call for economizer cooling, the outdoor air damper may be opened further to satisfy the cooling request.

**Figure 111. Damper position**

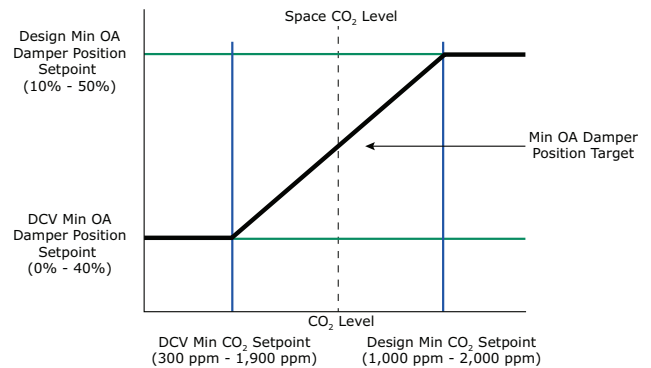

When the unit is in the unoccupied mode, DCV control is deactivated.

**Note:** When using CO<sub>2</sub>-based DCV with an RTRM (v8.0 or later) and also an RTEM, set the design min position setpoint to the minimum outdoor airflow required by the local building code. The DCV minimum position setpoint is typically based on, the minimum exhaust airflow rate from the building or the base ventilation rate required to dilute building- or process-related contaminants. See HUB document DOC-100458 for guidance on determining the CO<sub>2</sub> setpoints and OA damper position setpoints for a given application.

During normal occupied mode, if the unit is not actually heating or cooling, and the fan switch is set to auto, the supply fan will be off. If the unit is configured for active DCV control (DCV Mode OPEN), the supply fan will be energized when the space CO<sub>2</sub> level rises above the lower limit CO<sub>2</sub> setpoint and the DCV algorithm will be in control of the outdoor air damper position. When the space CO<sub>2</sub> level falls below the lower limit CO<sub>2</sub> setpoint minus 50 ppm,



DCV control will begin to close the damper to the DCV min position setpoint. Once the space CO<sub>2</sub> level is below the lower limit CO<sub>2</sub> setpoint minus 50 ppm and the OA damper is at the DCV min position the supply fan will de-energize if not requested on by another function.

### Active and Passive DCV Control

The RTEM allows the selection of either active or passive DCV control. Installing a jumper across J10-1 and J10-2 on the RTEM module configures the unit for passive DCV control. When configured for passive DCV control, DCV control is not allowed to force on the supply fan, and DCV control will only be allowed when the supply fan is on (commanded on by another function, such as comfort heating or cooling control, or the supply fan mode set to on). Passive DCV will operate identically to active DCV once the supply fan is energized.

**Important:** *While the ReliaTel™ will allow active DCV control when the fan mode is set to AUTO (cycle on and off with the compressor or heater), this practice is discouraged because it can result in excessive fan cycling and may not comply with ASHRAE Standard 62.1. If CO<sub>2</sub> based DCV is used, the supply fan mode should be set to on (operate whenever the zone is occupied) or the unit should be configured for passive DCV control.*

### DCV with Traq (27.5 to 50 Tons)

For units with Traq, when the optional CO<sub>2</sub> sensor is installed and demand controlled ventilation is enabled the minimum outside air cfm setpoint will be adjusted linearly between two airflow setpoints, the design minimum outside air (OA) cfm setpoint (R130) and the DCV minimum outside air cfm (OA) setpoint (R41). The resulting calculated setpoint is the minimum OA cfm Target which is the setpoint used for active airflow control. The minimum OA CFM target setpoint will vary proportionally between the DCV minimum OA flow cfm setpoint and the design minimum OA cfm setpoint as CO<sub>2</sub> varies between the CO<sub>2</sub> lower limit setpoint and the CO<sub>2</sub> upper limit setpoint. The CO<sub>2</sub> setpoints are set on the RTEM as with normal DCV control without Traq option.

The local design minimum OA cfm setpoint and/or DCV minimum OA flow setpoint (DCV option) is used unless a valid BAS/network minimum OA cfm setpoint has been selected and received in which case the BAS/network value is used. The BAS/network minimum OA cfm setpoint, if valid, overrides the DCV CO<sub>2</sub> reset calculation of minimum OA flow target as well.

### RTEM with RTRM v7.0 and Earlier

For units equipped with an RTRM v7.0 or earlier and also an RTEM, the control will utilize a single CO<sub>2</sub> setpoint and two separate damper minimum position setpoints as described below:

#### Setpoint Selection

Units equipped with an RTRM v7.0 or earlier will utilize a single CO<sub>2</sub> setpoint. The RTEM will use this setpoint and space CO<sub>2</sub> input value to determine the active OA damper position setpoint between the bldg design min position and DCV min position setpoints.

For DCV control in these units, the CO<sub>2</sub> setpoint will have a range of 500 to 1500 ppm. The bldg design min position will be set using the onboard potentiometer which will have a range of 10 to 50% and the DCV min position will be set using the onboard potentiometer which will have a range of 0 to 40%. This scheme enforces a 10% differential between the bldg design min position and the DCV min position setpoints.

#### Sequence of Operation

For units equipped with RTRM v7.0 or earlier and an RTEM, only active DCV control is available, as the DCV mode configuration input is not recognized prior to RTRM v8.0.

#### Supply Fan Mode = ON

When the unit is in the occupied mode, the outdoor-air (OA) damper opens to the DCV min position setpoint. If the space CO<sub>2</sub> level rises above the CO<sub>2</sub> setpoint, the OA damper will open to the bldg design min position setpoint. If the space CO<sub>2</sub> level drops below the CO<sub>2</sub> setpoint, but is not yet 50 ppm below the setpoint, the OA damper will stop modulating (holding its current position). If the space CO<sub>2</sub> level drops below the CO<sub>2</sub> setpoint minus 50 ppm, the OA damper will close to the DCV min position setpoint. If there is a call for economizer cooling, the outdoor air damper may be opened further to satisfy the cooling request.

#### Supply Fan Mode = AUTO (from Zone Sensor or all T-stat Inputs Inactive)

When the supply fan is energized (commanded on by another function, such as comfort heating or cooling control), DCV control will operate as described above (Supply Fan Mode = ON).

When the supply fan is de-energized, if the space CO<sub>2</sub> level rises above the CO<sub>2</sub> setpoint, DCV control will energize the supply fan and open the OA damper to the design min position setpoint. When the space CO<sub>2</sub> level drops below the CO<sub>2</sub> setpoint, the supply fan will be de-energized and the OA damper will close to 0%.

#### Failure and Override Conditions

If the CO<sub>2</sub> value goes invalid while DCV is enabled:

- A CO<sub>2</sub> sensor failure diagnostic is called out.
- DCV is disabled.

## Demand Control Ventilation (DCV)

- Design min position setpoint will be used for the damper min position.
- After power is cycled to the unit, the CO<sub>2</sub> sensor failure diagnostic is cleared and DCV is disabled.
- For all configurations, (RTEM, RTRM 8.0, Honeywell, etc.) if a CO<sub>2</sub> sensor value becomes valid at any point during unit operation the unit will utilize the value and perform demand controlled ventilation.
- If a ventilation override mode goes active it will take priority over DCV.
- If an emergency override mode goes active it will take priority over DCV.
- Any BAS economizer minimum position request takes priority over DCV.
- The remote minimum position input will be used as the design minimum position setpoint when connected.

- During unoccupied mode, the DCV setpoint is ignored.
- During occupied cooling or daytime warm-up (DWU) mode, DCV control is allowed.

Figure 112. Wiring connections using CO<sub>2</sub> accessory

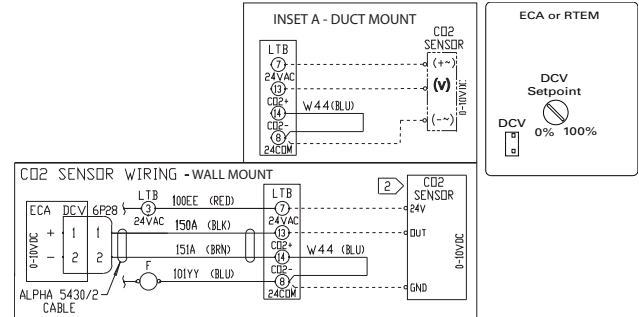

## Honeywell Operation

**Note:** *Obsolete - Honeywell only.*

When the indoor CO<sub>2</sub> level rises above the DCV setpoint (upper limit), the supply fan will energize, and a PID control loop modulates the position of the outdoor-air damper to bring in more outdoor air to maintain indoor CO<sub>2</sub> level at this upper limit (the operation of compressors or heat are not affected; they still operate to maintain space or discharge air temperature at setpoint). When the indoor CO<sub>2</sub> level drops back below this limit minus 50 PPM, the outdoor-air damper is allowed to return to its minimum position and the supply fan is allowed to de-energize if no longer requested.

**Note:** *When using CO<sub>2</sub>-based demand controlled ventilation with the ReliaTel™ controller, the minimum OA damper position should be set to be less than the code required design ventilation rate for the system. See HUB document DOC-78075 for guidance on determining the indoor CO<sub>2</sub> setpoint and minimum OA damper position for a given application.*

As a safety precaution, if the mixed air temperature drops to 40° F, the mixed air sensor overrides DCV control and closes the outdoor-air damper to its minimum position to protect the gas heat exchanger (or to prevent water coils, if installed, from freezing). When the mixed air temperature rises to 43° F, DCV control reverts to normal.

**Note:** *Since it is possible for the outdoor air damper to drive wide open, it is also recommended to install an evaporative defrost control to prevent the evaporator coil from freezing (Frostat™ is a standard feature on the Voyager™ commercial 27.5 to 50 ton units).*

## Precedent™, Voyager II, and Voyager III VAV/MZVAV Notes

- During morning warm-up (MWU), the DCV setpoint is ignored.

## Demand Controlled Ventilation (CO<sub>2</sub>) Set-up for Single Zone VAV, Multi-Speed and 17 Plus units

Because of the need to maintain the same outdoor cfm during different fan speeds, set up of demand controlled ventilation is different than for constant volume units.

There are three fan speed reference points which will be referred to as low, medium, and high fan speeds.

The DCV set up procedure should be done in test mode.

- The supply fan test (1st step in test mode) forces the supply fan in the low fan speed.
- The compressor stage 1 test (3rd step in test mode) forces the supply fan into the medium fan speed.
- The compressor stage 2 test (4th step in test mode) forces the supply fan to the high fan speed.

It is highly recommended to connect the CO<sub>2</sub> sensor directly at the unit to LTB4 for convenience. It is much more difficult to verify set points and functionality with the CO<sub>2</sub> sensor in the space away from the unit. Breathing on the CO<sub>2</sub> sensor simulates a high CO<sub>2</sub> concentration in the space.

In addition to the RTEM (ReliaTel™ economizer module) a circuit board called the RTVM (ReliaTel™ ventilation module) is required for DCV operation on light commercial multi-speed supply fan and single zone VAV units. This module is based off of the RTOM (ReliaTel™ options Module) but the RTVM has different components and firmware installed. The RTVM is mounted next to the RTOM or in the return air section. See the accessory kit instructions for installation details.

Figure 113. RTVM callouts

RTVM R41 potentiometer adjusts the DCV minimum economizer damper position for low and medium fan speeds

RTVM R130 potentiometer adjusts the design minimum economizer damper position for LOW speed indoor fan conditions (FAN stage in test mode)

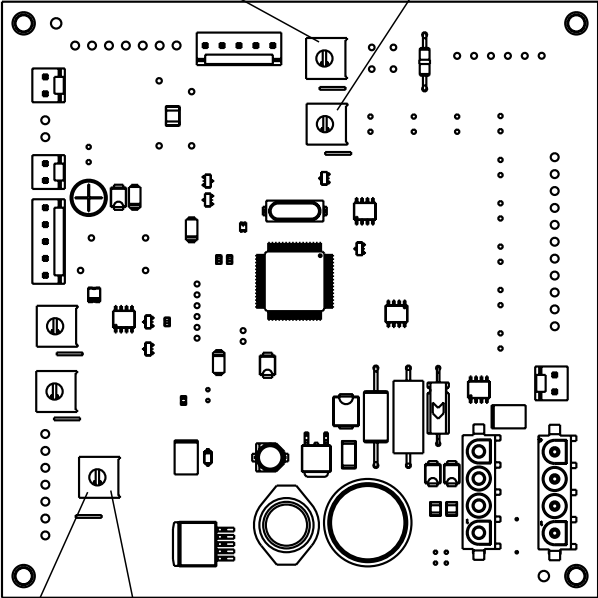

DA Cool Fan SPD

RTVM R136 potentiometer adjusts the design minimum economizer damper position for MEDIUM fan speeds (Stage 1 compressor in test mode)

Figure 114. RTEM for DCV with SZVAV

The RTEM DCV minimum position potentiometer adjusts the DCV minimum economizer damper position for the HIGH fan speed conditions (adjust while in compressor stage 2 inatest mode).

The RTEM DESIGN minimum position potentiometer adjusts the Design minimum economizer damper position for the HIGH fan speed conditions (adjust while in compressor stage 2 in test mode).

The LL (lower limit) adjusts the CO<sub>2</sub> concentration (PPM) setpoint at which the damper begins to ventilate the space.

The UL (upper limit) potentiometer adjusts the CO<sub>2</sub> concentration at which the economizer damper is fully driven the DESIGN damper position.

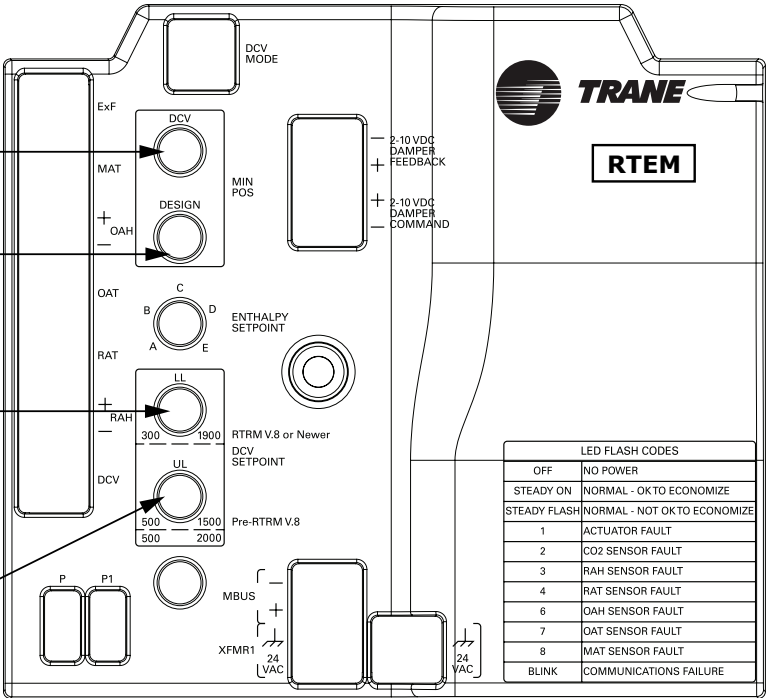

### Initial Set-up

1. For damper position adjustment, the lower limit (LL) CO<sub>2</sub> PPM adjustment potentiometer should be set to the lowest position (counter clockwise) and the upper limit (UL) CO<sub>2</sub> PPM adjustment potentiometer should be set to approximately halfway. These can be adjusted later to the required CO<sub>2</sub> levels.
2. A CO<sub>2</sub> sensor should be wired at the unit at LTB4 for the convenience of setup.
3. All three of the design minimum adjustment potentiometers (R130 on the RTVM, R136 on the RTVM, and design minimum on the RTEM) should be set to the maximum position (fully clockwise) and both of the DCV minimum adjustment potentiometers (R41 of the RTVM and DCV min of the RTEM) should be set to the minimum position as a starting position.

### Set-up the LOW Fan Speed Damper Positions

1. Enter into the test mode to the supply fan test step (1st step in test mode).
2. Adjust the R130 potentiometer on the RTVM to set the low fan speed design minimum damper position. The design minimum position set point controls the damper position when there is a high concentration of CO<sub>2</sub> in the space and ventilation is required. The damper can be set from 0% open to 100% open during the low fan speed.
3. Adjust the R41 potentiometer on the RTVM to set the low and medium fan speed DCV minimum position. The DCV minimum position set point controls the damper position when there is a low concentration of CO<sub>2</sub> in the space. The damper can be set from 0% open to 100% open in the low fan speed.
4. Ensure that the R130 low fan speed design minimum damper position is set greater than the low fan speed DCV minimum damper position.
5. Blow on the CO<sub>2</sub> sensor to simulate a high concentration of CO<sub>2</sub> to confirm the economizer damper responds to the call for ventilation.

**Note:** This procedure must be repeated for the medium and high fan speeds.

### Set-up the MEDIUM Fan Speed Damper Position

1. Advance to the 3rd step in the test mode (1st stage compressor). This forces the supply fan to the medium fan speed.
2. Adjust the R136 potentiometer on the RTVM to set the medium fan speed design minimum damper position. The damper can be set from 0% open to approximately 75% open in the medium fan speed.
3. There is no DCV min setup for medium fan speed. The value from R41 from the previous step is retained for the medium fan speed.
4. Blow on the CO<sub>2</sub> sensor to simulate a high concentration of CO<sub>2</sub> to confirm the economizer damper responds to the call for ventilation.

### Set-up the HIGH Fan Speed Damper Positions

1. Advance to the full compressor cooling in the test mode (both compressor running) or any stage of heat. This forces the supply fan to the high fan speed.
2. Adjust the design min potentiometer on the RTEM to set the high fan speed design minimum damper position. The damper can be set from 0% open to approximately 50% open in the high fan speed.
3. Adjust the DCV min potentiometer on the RTEM to set the high fan speed DCV minimum position.
4. Blow on the CO<sub>2</sub> sensor to simulate a high concentration of CO<sub>2</sub> to confirm the economizer damper responds to the call for ventilation.
5. After this procedure is finished adjust the lower limit (LL) CO<sub>2</sub> PPM adjustment potentiometer and the upper limit (UL) CO<sub>2</sub> PPM adjustment potentiometer on the RTEM to the required settings for the application. This is often determined by local codes.

#### Notes:

- RTVM modules for light commercial units are different than RTVM modules for large commercial units and are not interchangeable.
- Design minimum position set up is different for light commercial multi-speed supply fan and single-zone VAV units without DCV.
- Communicated BAS setpoints override any local potentiometer setting.

# Dehumidification

## Hot Gas Reheat 3 to 25 Tons

Factory installed hot gas reheat allows application of dehumidification. Initiation of reheat is performed by an input to the RTOM module from either a relative humidity sensor or a humidistat type device. These connections are made through the low voltage terminal strip located in the unit control panel. For sequence of operation of enhanced dehumidification or hot gas reheat with enhanced dehumidification, see the section SZVAV, multispeed, 17 plus.

Actuation of the reheat is accomplished by energizing a valve that allows refrigerant hot gas to flow through the hot gas reheat coil.

Dehumidification is allowed only when the outside air temperature is above 40°F and below 100°F.

During a dehumidification cycle, if there is a call for heating or request for greater than 50% cooling, the dehumidification cycle is terminated. The economizer outside air damper is also driven to minimum position during dehumidification.

A humidity sensor that is capable of providing a 4 - 20 ma output can be used. The RH setpoint is established by adjusting the R41 potentiometer (labeled Dehumid SP) on the RTOM module. The range can be set from 40 to 65%. In the absence of a zone humidity sensor input, an on/off input from a zone humidistat is used to initiate or terminate the dehumidification cycle.

A relative humidity sensor takes priority over a humidistat. Dehumidification takes priority over a call for one stage cooling. Heating or 2 stage cooling takes priority over dehumidification.

## Sequence of Operation

### Single Compressor Units

On a call for dehumidification, the reheat valve is energized and the compressor is turned on. When the humidity control setpoint is satisfied, the valve is de-energized and the compressor is turned off. If there is a call for cooling or heating from the space temperature controller, i.e. zone sensor or thermostat, while in reheat, the reheat valve is de-energized and the compressor continues to run, or the heat is turned on. The three minute compressor on and off times are still active during compressor operation.

### Dual Compressor Units

On a call for dehumidification, the reheat valve is energized and both compressors are turned on. When the humidity control setpoint is satisfied, the valve is de-energized and both compressors are turned off. If there is a call for 1st stage cooling from the zone sensor or thermostat while in the dehumidification mode, no action takes place.

If there is a call for heating or 2nd stage cooling, the reheat valve is de-energized, and the unit reverts to the cooling or heating mode. If 2nd stage cooling is satisfied and there is

still a call for dehumidification, the reheat valve will once again be energized, and the second compressor will again be started. The three-minute compressor on and off times are still active during compressor operation.

If both compressors are running, and there is a call for dehumidification, the dehumidification call is ignored and unit stays in the cooling mode.

Refer to appropriate unit wiring diagrams for control connections.

For reliability reasons, a purge time function was added to ensure adequate oil is being returned to the compressor.

During normal cooling mode or during dehumidification mode, if the unit stays in a mode for 90 continuous minutes without switching to the other mode, a three minute purge time will initiate.

If the unit has been in cooling mode for 90 minutes, the purge sequence will switch to the dehumidification mode for three minutes. If there is still a call for cooling, the unit will once again switch back to cooling.

The same sequence is also true if unit is in the dehumidification mode. It will switch to cooling for three minutes and then back to dehumidification.

**Figure 115. Relative humidity sensor locations**

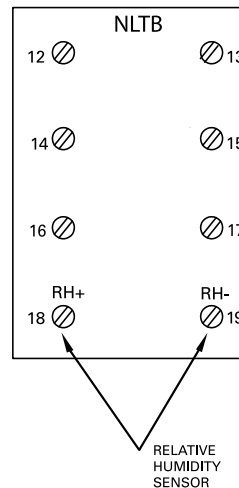

A unit with dehumidification installed will operate normally if a humidity sensor or humidistat is not installed. The compressor will switch to the dehumidification mode for a total of three minutes after 90 minutes of compressor run time in the cooling mode.

Verification of the RH setpoint can be determined by measuring the dc voltage at TB1 and TB2 on the RTOM.

**Table 117. RTOM dehumidification setpoint**

| Voltage (VDC) | Setpoint (%) |
|---------------|--------------|
| 0.002         | 40           |
| 0.238         | 41           |
| 0.445         | 42           |

**Table 117. RTOM dehumidification setpoint (continued)**

| Voltage (VDC) | Setpoint (%) |
|---------------|--------------|
| 0.539         | 43           |
| 0.677         | 44           |
| 0.811         | 45           |
| 0.984         | 46           |
| 1.117         | 47           |
| 1.245         | 48           |
| 1.349         | 49           |
| 1.428         | 50           |
| 1.552         | 51           |
| 1.625         | 52           |
| 1.745         | 53           |
| 1.824         | 54           |
| 1.853         | 55           |
| 1.929         | 56           |
| 1.978         | 57           |
| 2.07          | 58           |
| 2.136         | 59           |
| 2.184         | 60           |
| 2.259         | 61           |
| 2.268         | 62           |
| 2.324         | 63           |
| 2.397         | 64           |

Calculation to convert mA to RH = (mA reading - 4) \* 6.25

4mA = 0%

20mA = 100%

Example: (12mA - 4) \* 6.25 = 50% RH

To measure the mA input current from the humidity sensor, disconnect sensor wire that is connected to terminal 18 of LTB. Connect amp meter in series with the wire and terminal 18 of the LTB.

**Table 118. Humidity sensor measurements**

| mA | %     |
|----|-------|
| 4  | 0     |
| 5  | 6.25  |
| 6  | 12.5  |
| 7  | 18.75 |
| 8  | 25    |
| 9  | 31.25 |
| 10 | 37.5  |
| 11 | 43.75 |
| 12 | 50    |
| 13 | 56.25 |
| 14 | 62.5  |
| 15 | 68.75 |
| 16 | 75    |
| 17 | 81.25 |
| 18 | 87.5  |
| 19 | 93.75 |
| 20 | 100   |

Dehumidification/reheat is disabled if any of these conditions exist:

- Active unit mode = Off with zone sensor.
- Humidistat active open from humidity stat.

- Active humidity is less than active humidity set point – 5%.
- Outdoor air temperature is less than 40° F or invalid or greater than 100°F and one compressor.
- Compressor one (or two for multi-compressor units) auto or manual reset lockout.
- Active call for heating.
- Minion mode is active and requesting the supply fan off.
- Dehumidification setpoint is set to 0% (Tracer® override).
- If using a zone sensor and unit mode is set to manual/ heat and active zone temp is greater than or equal to active zone cool setpoint.
- If using a zone sensor and unit mode is set to manual/ cool and active zone temp is less than active zone heat setpoint plus 0.5° F.

## Modulating Dehumidification with Hot Gas Reheat (27.5 to 50 Tons)

### Controls Overview

- Reheat low pressure cutout (RLP) opens / trips when suction pressure is less than 60 psi and only active during reheat mode.
  - Note:** Can lock out mechanical cooling in reheat or cooling mode if RLP is open before compressor starts.
- Additional 60# low pressure cutout ignored for the first 10 minutes of compressor run time in reheat mode.
- Will also be active during service test.
- Two modulating valves are controlled by the discharge air temperature sensor
- Cooling mode: Cooling valve 100% open, Reheat valve 0% open.
- Reheat mode: Cooling and reheat valves open/close inverse of each other. Reheat valve allowed to operate from 15 to 85% open.
- Reheat pump out solenoid is energized when in cooling mode. It is inactive in all other modes.
- A three minutes purge cycle will take place after one continuous hour (hard coded) of operation in reheat or cooling mode.
- Entering evaporator temperature (overrides Froststat™ during reheat)
- During reheat operation if Entering Evaporator Temp (EET) is below 35°F for 10 continuous minutes the control will shed compressors (or circuits on dual circuit units) and will not stage up to full compressor capacity again until leaving reheat mode. If the EET remains below 35°F for 10 more continuous minutes all compressors will stage off and the evaporator fan will

continue to run. Once reaching 45°F the compressor (circuit) will be re-enabled but not at full capacity.

- The condenser fans will be staged differently in reheat mode than cooling mode.
  - Single circuit units (three total condenser fans): A maximum of two outdoor fans above 85°F and a maximum of one outdoor fan below 80°F.
  - Dual circuit units (four total condenser fans): A maximum of four outdoor fans above 85°F and a maximum of two outdoor fans below 80°F.

**Figure 116. Voyager™ commercial modulating hot gas reheat**

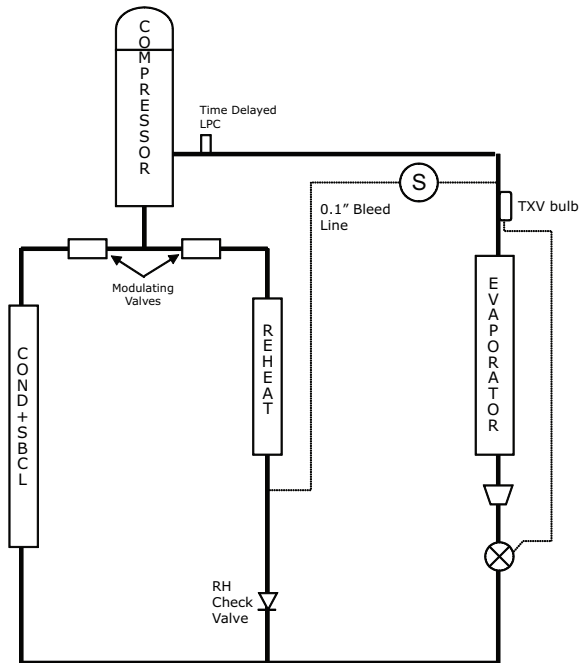

- RTRM handles the main dehumidification logic.
- RTOM contains the humidity and supply air setpoint.
- RTDM (new module) handles the reheat/cooling valve and pump out relay control.
- Customer adjustable setpoints.
- Supply air reheat setpoint located on RTOM (65-80°F default 70°F).
- Dehumidification (humidity) setpoint located on RTOM (40-65% default 50%).
- VAV dehumidification override zone cooling and heating setpoints (75°F cooling, 68°F heating). A

customer can adjust them if a CV remote zone sensor is connected to the RTRM or by using resistors.

- CV, SZVAV space temperature override if the zone temperature has dropped to the zone heating setpoint + 0.5°F.
- CV, SZVAV space temperature override if the zone temperature rises above the zone cooling setpoint +2°F in any unit mode.

**Figure 117. Modulating hot gas reheat control boards**

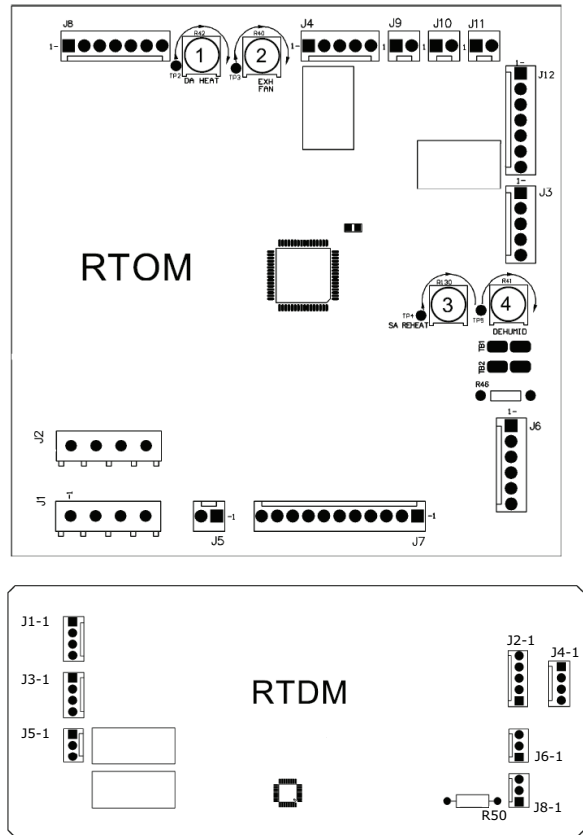

**Table 119. Modulating hot gas reheat control board setpoints**

| Setpoint Legend |                         |              |
|-----------------|-------------------------|--------------|
| 1.              | Discharge Air Heat SP   | 50 to 150°F  |
| 2.              | Exhaust Fan Enable SP   | 0 to 100%    |
| 3.              | Supply Air Reheat SP    | 60 to 80°F   |
| 4.              | Dehumidification SP (%) | 40 to 65% RH |

# Heating/Cooling Changeover

The change over from heating to cooling is accomplished in two different ways. The first drawing below illustrates change over in a system without an economizer, and the second drawing illustrates change over in a system with an economizer. Changeover from cooling to heating is accomplished in the same manner for both economizer and non-economizer systems.

If the unit is in the cooling mode and the zone temperature is falling, the unit will change to the heating mode when the zone temperature is less than the heating set point and it has been 5 minutes since the last active call for cooling was terminated. For systems without economizers or with economizers, but the economizer is enthalpy disabled, if the unit is in the heating mode, and the zone temperature is rising, the unit will change to the cooling mode when the zone temperature is greater than the greater of the active cooling setpoint or active heating setpoint + 3°F, and it has been 5 minutes since the last active call for heating has been terminated. For systems with economizers and the

economizer is enthalpy enabled, if the unit is in the heating mode, and the zone temperature is rising, the unit will change to the cooling mode when the zone temperature is greater than the greater of the economizer setpoint or the active heating setpoint + 3°F, and it has been 5 minutes since the last active call for heating has been terminated.

**Figure 118. Heating/cooling changeover**

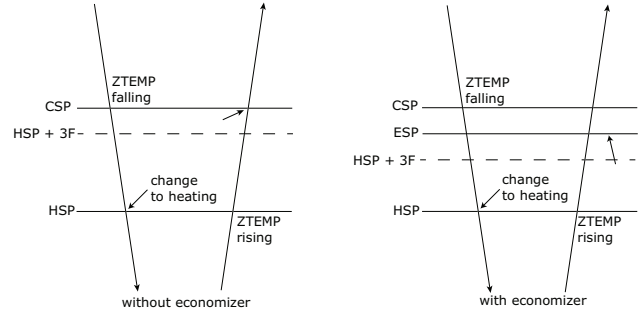



# Low Ambient Operation (3 to 25 Ton Units)

## Evaporator Defrost Control (EDC) Function

The evaporator defrost control (EDC) function provides low ambient cooling, standard, down to 0° F. At this temperature, equipment can provide approximately 60% of the mechanical cooling capacity. During low ambient operation compressor run time is counted and accumulated by the RTRM.

Low ambient operation is defined as 55° F for single compressor units, and 40° F for dual compressor units. Dual condenser fan units provide condenser cycling.

**Note:** *If the outside air sensor fails, the EDC logic is disabled and the #2 condenser fan will run continuously.*

|            |     |  |   |   |   |   |   |   |   |   |    |     |    |    |    |    |    |    |    |
|------------|-----|--|---|---|---|---|---|---|---|---|----|-----|----|----|----|----|----|----|----|
| Compressor | OFF | ON (10 min. accumulated compressor run time)     |   |   |   |   |   |   |   |   |    | OFF | ON |    |    |    |    |    |    |
| Indoor Fan | OFF | ON (Continues to run during 3 min. defrost time) |   |   |   |   |   |   |   |   |    |     |    |    |    |    |    |    |    |
| Minutes    | 0   | 1  | 2 | 3 | 4 | 5 | 6 | 7 | 8 | 9 | 10 | 11  | 12 | 13 | 14 | 15 | 16 | 17 | 18 |

When accumulated compressor run time reaches approximately 10 minutes, an evaporator defrost cycle is initiated. An evaporator defrost cycle lasts for 3 minutes; this matches the compressor 3 minutes minimum OFF time.

When an evaporator defrost cycle occurs, the compressors are turned off and the indoor fan motor continues to run. After completing an evaporator defrost cycle, the unit returns to normal operation, and the compressor run time counter is reset to zero.

**Note:** *Economizer operation is not affected by an evaporator defrost cycle.*

## Voyager 12.5 to 25 Tons Packaged Rooftop Units

### Evaporator Defrost Control (Frostat™)

| Kit Model   | Equipment Used With   | Literature Reference |
|-------------|---|----------------------|
| BAYLOAM023* | 12.5 to 25 Tons Packaged Rooftop units with ReliaTel™ Communications Module | ACC-SVN101*-EN       |
| BAYLOAM031* | T/YH*210-300, WS*240, T/YZ*150-210  |                      |
| BAYLOAM777* | T/YSC150-300 (Microchannel Evaporators)                                     |                      |

## Low Ambient Kits

### Precedent™

Table 120. Precedent

| Kit Model   | Equipment Used With                                       | Literature Reference |
|-------------|---|----------------------|
| BAYLOAM020* | Precedent™ 3 to 10 Ton with Fin and Tube Evaporator Coils | ACC-SVN50*-EN        |
| BAYLOAM120* | Precedent™ 3 to 10 Ton with MicroChannel Evaporator Coils |                      |

### Head Pressure Control

| Kit Model    | Equipment Used With           | Literature Reference |
|--------------|-------------------------------|----------------------|
| BAYLOAM187*  | T/YS*150-301 and T/YH*150-301 | ACC-SVN106*-EN       |
| BAYLOAM188** | T/YS*150-301 and T/YH*150-301 | ACC-SVN107*-EN       |

## Low Ambient Operation (3 to 25 Ton Units)

### Odyssey

| Kit Model   | Equipment Used With  | Literature Reference |
|-------------|--|----------------------|
| BAYLOAMU01* | TTA060/061/072/073/076/090, TWA061D/073D/076D/090D, TWA090A, TWA0604*A/0724*A/0764*A/0904*A, TWA0902*A   | ACC-SVN118*-EN       |
| BAYLOAMU02* | TTA101/120/126/150/156/180/201/240/251/300, TWA061E/073E/076E/090E, TWA0604*D/0724*D/0764*D/0904*D/101/120/156/180/201/240   |                      |
| BAYLOAM335* | TTA07243A, TTA09043A, TWA07243A/D, TWA09043A/D   | ACC-SVN136*-EN       |
| BAYLOAM336* | TTA12043A/C/D, TTA15043D, TTA18043C/D, TTA24043C/D, TTA30043C, TWA12043A/D, TWA18043D, TWA24043D   |                      |
| BAYLOAM436* | TTA1014DA/C/D, TTA12044A/C/D, TTA1264DD, TTA15044D, TTA1564DC/D, TTA18044C/D, TTA2014DC/D, TTA24044C/D, TTA2514DC, TTA30044C, TWA1014DA/D, TWA12044A/D, TWA1564DD, TWA18044D, TWA2014DD, TWA24044D |                      |
| BAYLOAMW36* | TTA1204WA/C/D, TTA1504WD, TTA1804WC/D, TTA2404WC/D, TTA3004WC, TWA1204WA/D, TWA1804WD, TWA2404WD   |                      |
| BAYLOTR001* | BAYLOAM335*, 336*, 436*, W36* (TTA120**D, TTA150**D).<br>Transducer kit required when modulating BAYLOAM kit used with units that have 2 compressors (dual circuit) and 1 condenser fan.           | N/A                  |

# ReliaTel™ - Condenser Fan

## Control Logic - 12.5 to 25 Tons

For units that have two condenser fans, special control logic is designed to provide proper condenser head pressure control at different ambient conditions. With normal operation, either one or both fans will be operating depending on the outdoor temperature.

Control logic resides in the RTRM module. When the outdoor ambient drops below 60 degrees the second condenser fan will be turned off. When the outdoor temperature reaches 65° the fan will once again restart.

When only one condenser fan is running, the second fan will windmill backwards. This is caused by air being drawn in through the opening of the fan orifice which bypasses the condenser coil. If the windmilling is fast enough and the condenser fan is energized, it can actually start and run in the reverse direction. To prevent this, when there is a call for the second condenser fan to start, control logic forces the first condenser fan to shut off for seven seconds to allow the second fan to slow down. After seven seconds, both the first and the second condenser fan will restart. Because the contactors that provide power to the condenser fan are also the same ones used to power the compressors, both compressors (if the second compressor is running) will also shut down during the seven second interval. When the fans restart, the compressor will also restart.

## Sequence for eFlex™ Units

The same signal from the VSM that controls the compressor speed also controls the speed of the condenser fans. The condenser fan speed is determined

by the variable speed compressor speed and the outdoor air temperature.

## Sequencing Control - 27.5 to 50 Tons

The condenser fans are cycled according to the outdoor air temperature and the number of cooling steps that are operating. [Table 121, p. 176](#) lists the temperatures at which the A and B condenser fan outputs on the RTRM switches the fans off. The fans are switched back on when the outdoor temperature rises approximately 5°F above the off temperature.

[Figure 119, p. 175](#) shows the condenser fans as viewed from the top of the unit facing the control panel. Whenever a condenser fan is cycled back on, the condenser fan outputs A and B and the compressor steps are de-energized for approximately seven seconds to prevent problems with fan windmill.

**Figure 119. Condenser fan location**

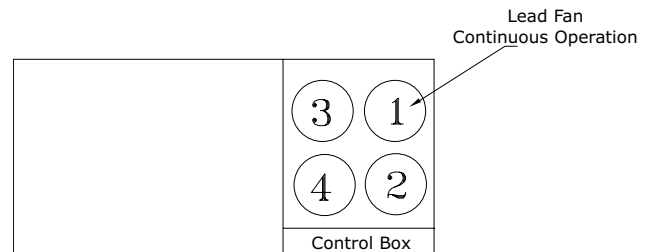

**Table 121. Condenser fan/compressor sequence - standard efficiency**

| Unit Size (Ton) | Compressor Staging Sequence |                        |            | Condenser Fan Output |           | O/A Temp. (°F) |
|-----------------|-----------------------------|------------------------|------------|----------------------|-----------|----------------|
|                 | Step 1                      | Step2                  | Step 3     | Output A             | Output B  | Fans off       |
| 27.5 - 30       | CPR1 <sup>(a)</sup>         | CPR1, 2                | NA         | Fan #2               | Fan #3    | 70             |
|                 |                             |                        |            |                      |           |                |
|                 |                             |                        |            | Fan #2               | Fan #3    | -10            |
|                 |                             |                        |            |                      |           | 60             |
| 35              | CPR1 <sup>(a)</sup>         | CPR1, 2                | NA         | Fan #2               | Fan #3    | 65             |
|                 |                             |                        |            |                      |           |                |
|                 |                             |                        |            | Fan #2               | Fan #3    | -20            |
|                 |                             |                        |            |                      |           | 55             |
| 40 VAV only     | CPR1 <sup>(b)</sup>         | CPR2 <sup>(c)</sup>    | CPR1, 2    | Fan #2               | Fan #3, 4 | 50             |
|                 |                             |                        |            |                      |           |                |
|                 |                             |                        |            |                      | Fan #2    | Fan #3, 4      |
|                 |                             |                        |            |                      | 60        |                |
|                 |                             |                        |            | Fan #2               | Fan #3, 4 | -30            |
|                 |                             |                        |            |                      |           | 50             |
| 50 VAV only     | CPR1 <sup>(b)</sup>         | CPR2, 3 <sup>(d)</sup> | CPR1, 2, 3 | Fan #2               | Fan #3, 4 | 20             |
|                 |                             |                        |            |                      |           |                |
|                 |                             |                        |            |                      | Fan #2    | Fan #3, 4      |
|                 |                             |                        |            |                      | 55        |                |
|                 |                             |                        |            | Fan #2               | Fan #3, 4 | -30            |
|                 |                             |                        |            |                      |           | 50             |

**Notes:**

1. The compressor(s) listed under each step are the operating compressors. On 27.5 to 35 ton units with lead/lag, CPR1 will alternate but the fan sequence will remain the same. On 40 and 50 ton units with lead/lag, the compressor(s) in step 2 and 3 will alternate and the fan sequence listed for that step will be in operation.
2. Conventional thermostat sequence: Y1=CPR1, Y2=CPR2 (40 CPR 2 and 50 CPR 2,3), Y1 + Y2 = CPR1,2 (40 CPR 1,2 and 50 CPR 1,2,3).
3. During active hot gas reheat all compressors will be staged on. For units equipped with four condenser fans (40 and 50 ton), the condenser fan output states will be controlled based on the O/A temperature. If O/A is above 85°F, all condenser fan outputs will be energized. If O/A falls below 80°F, output B will de-energize and will not re-energize again until the O/A rises above 85°F. For units configured with three condenser fans (27.5 to 35 tons), a maximum of two condenser fans will energize. Output A will energize above 85°F and de-energize when the O/A falls below 80°F. Output B will remain de-energized during active hot gas reheat. If O/A falls below 80°F, output A will de-energize and will not re-energize again until O/A rises above 85°F.

<sup>(a)</sup> Single circuit, manifolded compressors pair.

<sup>(b)</sup> First stage, number one refrigeration circuit, standalone compressor is on.

<sup>(c)</sup> First stage is off, number two refrigeration circuit, standalone compressor is on.

<sup>(d)</sup> First stage is off, number two refrigeration circuit, manifolded compressor pair is on operating simultaneously.

Table 122. Condenser fan/compressor sequence - high efficiency

| 27.5 to 35 Tons High Efficiency                   |        |              |                   |                |   |        |              |                   |                |
|---|--------|--------------|-------------------|----------------|---|--------|--------------|-------------------|----------------|
| Compressor Stage 1                                |        |              |                   |                | Compressor Stage 2                                |        |              |                   |                |
| Fan #1  | Fan #2 | Fan #3       | Ambient Range (F) | # Cond Fans On | Fan #1  | Fan #2 | Fan #3       | Ambient Range (F) | # Cond Fans On |
| ON  | OFF    | OFF          | 0-70              | 1              | ON  | OFF    | OFF          | 0-58              | 1              |
|   | OFF    | OFF          | 70-75             | 1 or 2         |   | OFF    | OFF          | 58-63             | 1 or 2         |
|   | ON     | OFF          | 75-80             | 2              |   | ON     | OFF          | 63-70             | 2              |
|   | ON     | OFF          | 80-85             | 2 or 3         |   | ON     | OFF          | 70-75             | 2 or 3         |
|   | ON     | ON           | 85-115            | 3              |   | ON     | ON           | 75-115            | 3              |
| 27.5 to 35 Tons High Efficiency                   |        |              |                   |                |   |        |              |                   |                |
| Compressor Stages 3 or 4                          |        |              |                   |                | Compressor Stage 5                                |        |              |                   |                |
| Fan #1  | Fan #2 | Fan #3       | Ambient Range (F) | # Cond Fans On | Fan #1  | Fan #2 | Fan #3       | Ambient Range (F) | # Cond Fans On |
| ON  | OFF    | OFF          | 0-60              | 1              | ON  | OFF    | OFF          | 0-50              | 1              |
|   | OFF    | OFF          | 60-65             | 1 or 2         |   | OFF    | OFF          | 50-55             | 1 or 2         |
|   | ON     | OFF          | 65-70             | 2              |   | ON     | OFF          | 55-60             | 2              |
|   | ON     | OFF          | 70-75             | 2 or 3         |   | ON     | OFF          | 60-65             | 2 or 3         |
|   | ON     | ON           | 75-115            | 3              |   | ON     | ON           | 65-115            | 3              |
| 40 Ton High Efficiency and Standard Efficiency CV |        |              |                   |                |   |        |              |                   |                |
| Compressor Stages 1 and 2                         |        |              |                   |                | Compressor Stages 3 and 4                         |        |              |                   |                |
| Fan #1  | Fan #2 | Fan #3 and 4 | Ambient Range (F) | # Cond Fans On | Fan #1  | Fan #2 | Fan #3 and 4 | Ambient Range (F) | # Cond Fans On |
| ON  | OFF    | OFF          | 0-60              | 1              | ON  | OFF    | OFF          | 0-40              | 1              |
|   | OFF    | OFF          | 60-70             | 1 or 2         |   | OFF    | OFF          | 40-45             | 1 or 2         |
|   | ON     | OFF          | 70-80             | 2              |   | ON     | OFF          | 45-75             | 2              |
|   | ON     | OFF          | 80-85             | 2 or 4         |   | ON     | OFF          | 75-80             | 2 or 4         |
|   | ON     | ON           | 85-115            | 4              |   | ON     | ON           | 80-115            | 4              |
| 40 Ton High Efficiency and Standard Efficiency CV |        |              |                   |                | 50 Ton High Efficiency and Standard Efficiency CV |        |              |                   |                |
| Compressor Stage 5                                |        |              |                   |                | Compressor Stages 1 and 2                         |        |              |                   |                |
| Fan #1  | Fan #2 | Fan #3 and 4 | Ambient Range (F) | # Cond Fans On | Fan #1  | Fan #2 | Fan #3 and 4 | Ambient Range (F) | # Cond Fans On |
| ON  | OFF    | OFF          | 0-40              | 1              | ON  | OFF    | OFF          | 0-60              | 1              |
|   | OFF    | OFF          | 40-45             | 1 or 2         |   | OFF    | OFF          | 60-65             | 1 or 2         |
|   | ON     | OFF          | 45-65             | 2              |   | ON     | OFF          | 65-75             | 2              |
|   | ON     | OFF          | 65-70             | 2 or 4         |   | ON     | OFF          | 75-80             | 2 or 4         |
|   | ON     | ON           | 70-115            | 4              |   | ON     | ON           | 80-115            | 4              |
| 50 Ton High Efficiency and Standard Efficiency CV |        |              |                   |                |   |        |              |                   |                |
| Compressor Stages 3 and 4                         |        |              |                   |                | Compressor Stage 5                                |        |              |                   |                |
| Fan #1  | Fan #2 | Fan #3 and 4 | Ambient Range (F) | # Cond Fans On | Fan #1  | Fan #2 | Fan #3 and 4 | Ambient Range (F) | # Cond Fans On |
| ON  | OFF    | OFF          | 0-35              | 1              | ON  | OFF    | OFF          | 0-35              | 1              |
|   | OFF    | OFF          | 35-40             | 1 or 2         |   | OFF    | OFF          | 35-40             | 1 or 2         |
|   | ON     | OFF          | 40-70             | 2              |   | ON     | OFF          | 40-60             | 2              |
|   | ON     | OFF          | 70-75             | 2 or 4         |   | ON     | OFF          | 60-65             | 2 or 4         |
|   | ON     | ON           | 75-115            | 4              |   | ON     | ON           | 65-115            | 4              |

Notes:

1. Condenser fan will de-energize at 5°F below the energizing temperature.
2. Compressor Stage 1 = CPR1
3. Compressor Stage 2 = CPR2 or CPR3 depending on staging sequence
4. Compressor Stage 3 = CPR1 and CPR2 or CPR2 and CPR3 depending on staging sequence
5. Compressor Stage 4 = CPR2 and CPR3
6. Compressor Stage 5 = CPR1 and CPR2 and CPR3
7. Conventional three stage thermostat sequence: Y1=CPR1 (Stage 1), Y2=CPR1 and 2 (Stage 3), Y1 + Y2 = CPR1,2,3 (Stage 5)
8. During active hot gas reheat all compressors will be staged on. For units equipped with four condenser fans (40 and 50 ton), the condenser fan output states will be controlled based on the O/A temperature. If O/A is above 85°F, all condenser fan outputs will be energized. If O/A falls below 80°F, output B will de-energize and will not re-energize again until the O/A rises above 85°F. For units configured with three condenser fans (27.5 to 35 ton), a maximum of two condenser fans will energize. Output A will energize above 85°F and de-energize when the O/A falls below 80°F; output B will remain de-energized during active hot gas reheat. If O/A falls below 80°F, output A will de-energize and will not re-energize again until O/A rises above 85°F.

## Independent Circuit Heat Pump - Odyssey™

For Odyssey™ independent heat pump units, the outdoor fan B output will be energized whenever compressor circuit

one is energized. The outdoor fan A output will be energized whenever compressor circuit two is energized. These statements hold true for active heating and cooling modes except during active defrost.

# Phase Monitor

## ReliaTel™ 3 to 25 Tons

Phase monitors are installed on all 3 to 25 ton products with three-phase power. The main purpose of the phase monitor is to ensure that the scroll compressors are rotating in the proper direction. A green LED on the phase monitor indicates proper phasing.

If the input leads are crossed, the phase monitor will sense this and will immediately shut the unit down. The monitor will illuminate a red LED indicating a phase reversal condition.

If the control wires are crossed on the Y and Y-out terminals on the phase monitor, this will also cause the red LED to illuminate and will not allow the unit to run.

If a red LED is displayed, swap two leads on the incoming power to the unit. If the red LED is still illuminated, check for proper control wiring connections to the phase monitor. If all wiring is correct, the phase monitor is defective and needs to be replaced.

Figure 120. Phase monitor wiring diagram

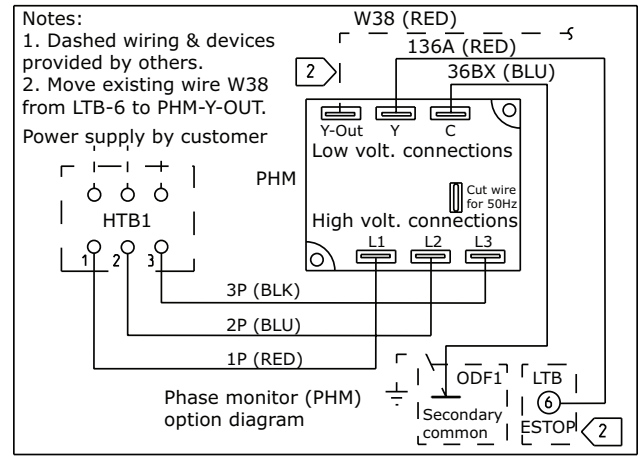

# Circuits

## Snubber Circuits

**Note:** *Obsolete on RTRM versions 11.0 and newer.*

ReliaTel™ controls utilize relays to energize alternating current (AC) loads. Because of the characteristics of AC loads dealing with inrush current, snubber circuits are used.

The purpose of a snubber circuit is to act as a filter to help dampen the voltage peaks associated with the opening and closing of the relay contacts. The snubber circuit is a resistive/capacitive circuit, with a resistor and capacitor wired in series across the on-board relay contacts.

Snubber circuits may cause confusion because 24 Vac will be present if the output wire is disconnected from the load; such as a relay or contactor coil, and the contacts of the board relay are open. The voltage potential between the disconnected wire and ground will be 24 Vac, but no current will be present. When the wire is placed back on the contactor coil, the 24 Vac potential will disappear. To properly verify whether voltage is present to energize a relay and contactor, the circuit must be complete and in tact.

**Figure 121. Snubber circuits**

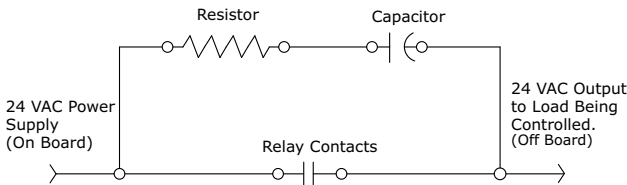

## High Pressure and Low Pressure Lockout Circuits

High pressure cutout (HPC) and low pressure cutout (LPC) circuits are designed to shut compressor operation down when pressures are too low, such as loss of charge; or too high, such as would result from dirty condenser coils.

The operational logic of these circuits is unique and requires explanation to fully understand how they operate.

### LPC Logic

LPC logic was changed with version 3.1 of the RTRM. Timing was changed from two minutes to 10 seconds to enhance compressor reliability due to no-flow issues for the TXV option during compressor starts.

Due to unexpected compressor lockout issues, the timing was again revised with version 6.0 of the RTRM. The timing function will be different depending on the outdoor temperature. If the OA temp is below 40°F, the timing is one minute. If OA temp is 40°F or above, timing is 30 seconds.

For RTRM version 8.0 + the timing has been revised and is still dependent on outdoor ambient temperature. If the outdoor temperature is less than 40°F the LPC bypass

delay will be set to 60 seconds. When the outdoor temperature is between 40 to 49.9°F the delay will be set to 30 seconds. For all outdoor temperatures 50°F and above, there will be no delay in setting a LPC. These delays will apply to all units.

### LPC Sequence of Operation

On a call for cooling, there is an LPC bypass delay period (depending on OA temp) where the LPC switch is ignored. If there is a low charge condition or low pressure condition due to extreme cold ambient conditions, the unit is allowed to run for the delay period to build up pressure.

If the switch is closed after the LPC bypass delay time, the compressor will continue to run. If the switch is open, the compressor will shut down immediately. After three minutes, if there is still an active call for cooling, the unit will once again start. If the switch is still open after the initial LPC bypass delay time, the compressor will again shutdown. The unit will try to start four times. If the switch is still open after the fourth try, the unit will shut down and be locked out, and will require a manual reset to start the unit again.

If the switch is closed and the compressor continues to run for three minutes, the counter is reset and the logic sequence starts over.

If the call for cooling goes away at any time during the routine, the counter is reset and the logic sequence starts over.

**Note:** *If the unit is configured as a heat pump and is actively heating with the outdoor ambient temperature at or below 0°F, or the unit is in an active defrost mode, the LPC inputs will be ignored.*

### LPC Operation for 27.5 to 50 Ton Units with Modulating Reheat

Units configured with modulating dehumidification will control compressors in regards to the compressor 1 and 2 disable inputs slightly different than traditional units and will also include an extra LPC switch connected to the RTDM. The following describes the implementation of this function for these units:

- RTRM compressor one disable input will function as today's units function.
- If active on a dual circuit unit, only circuit one will de-energize after the appropriate delays during active cooling. Both circuits will de-energize during active reheat (circuit two after its minimum on timer expires).
- If active on a single circuit dual compressor unit, compressor one and compressor two will de-energize after the appropriate delays during active cooling and active reheat.
- RTRM compressor two disable input will function as follows:



- If active on a dual circuit unit, only circuit two will de-energize during active cooling. Both circuits will de-energize after the appropriate delays during active reheat (circuit one after its minimum on timer expires).
- If active on a single circuit dual compressor unit, only compressor two will de-energize during active cooling and active reheat. Reheat will not be disabled in the case of the compressor two disable input going open on these units. This is to ensure that a customer who chooses to utilize the demand limit (load shedding) capabilities of the compressor two disable input will still have some reheat functionality. The LPC lockout incremental counter will not increment if this input goes active since it is not actually in the refrigeration system.

- RTDM low pressure cutout input:

The RTDM low pressure cutout input will be ignored for the first 10 minutes of compressor run time on the reheat circuit (or compressor one if on a single circuit, dual compressor unit). Once active (OPEN), the associated circuit/output will de-energize and not be allowed to re-energize until the three minute off timer is expired and the input has cleared. If the reheat LPC trips four times in any mode after the circuit has been energized for 10 minutes, dehumidification will be disabled (all compressors off) and the reheat circuit will be locked out.

**Note:** For dual circuit units, a lockout on the reheat circuit will not disable cooling for the opposite circuit.

The reheat LPC input will function in addition to the normal LPC input(s) located on the RTRM. For units with modulating reheat, the RTRM LPC for the reheat circuit will cause the unit to de-energize the appropriate circuit(s) and the total LPC count will be incremental. For these units, a total of four LPC events on the reheat circuit (any combination from the RTRM or the RTDM reheat circuit LPC inputs) will cause the unit to lock out the appropriate circuit (s). For dual circuit units, the RTRM LPC input for circuit two will function as on normal, non-reheat units. See below for unit configuration specific details:

- For Voyager™ commercial dual circuit units if the RTDM low pressure cutout input goes active (OPEN) after the reheat circuit has been active for 10 minutes, the reheat circuit (compressor two output) will de-energize along with circuit one (after its minimum on time) during active reheat. For dual circuit units, if the unit is in active cool mode, the non-reheat circuit will remain energized if the reheat LPC goes active. Once this input clears, the unit will allow dehumidification and cooling as necessary to meet demands and the inactive

circuit(s) will be allowed to re-energize after the 3 minute minimum off timer expires if necessary.

- For Voyager™ commercial single circuit (dual compressor) units if the RTDM low pressure cutout input goes active after 10 minutes of run time on compressor one, both compressors will de-energize during active reheat or active cooling. Once this input clears, the unit will allow dehumidification and cooling as necessary to meet demands and the inactive circuit (s) will be allowed to re-energize after the 3 minute minimum off timer expires if necessary.

There is no requirement to differentiate between the RTRM LPC inputs and the RTDM LPC input for BAS/Network systems. If the unit has either the RTRM LPC input go active for the reheat circuit or the RTDM LPC input go active, the control should just report an LPC event for that circuit, regardless of which input is reflecting the condition. Also, the counter for RTDM LPC events will not be reset unless power is cycled to the unit controller independent of how much time has passed since the last RTDM LPC event.

**Note:** This function will also be active during service test.

## HPC Logic

High pressure cutout (HPC) is similar to the LPC in that the unit may be given up to four tries to operate. Like the LPC, the HPC provides reliability protection for compressors, but it is also used for safety protection due to the high operating pressures that the unit may see.

**Note:** At no time should the HPC be removed or disabled in order to maintain unit operation.

## HPC Sequence of Operation

On a call for cooling, if the HPC switch is closed, the compressor will be allowed to start. If at any time the HPC opens, the unit will shut down immediately. After a 15 minute period, if there is still a call for cooling, the control logic will check to see if the switch has closed. If not, the unit is locked out and requires a manual reset to restart the unit.

If after 15 minutes the HPC is closed, and there is still a call for cooling, the unit will be allowed to restart. Once again, if the HPC opens, the unit will shut down and wait fifteen minutes to validate a restart. If the switch is closed, the unit will be allowed to restart.

If the HPC opens and closes four times during an active call for cooling, the unit will be shut down and locked out, and will require a manual reset.

If any time during the counter routine, the call for cooling goes away, the counter will reset and the logic sequence starts all over again.

# Transformer Troubleshooting

The graph shows how as current caused by loads on the transformer increases, voltage decreases. Once the voltage drops below the level that the contractor can stay solidly pulled in and begins to chatter, usually about 16-18 volts, the current raises up to the point where the transformer could burn out. The chart below is for illustration only.

A transformer usually burns out due to a short circuit. When this occurs, the technician can usually find the source of the short.

Sometimes though, the cause of transformer failure is not so obvious. It can also fail when excessive voltage drops occur because of poor connections, thermostat wires too long, bad contacts on the smoke detector, etc.

The excessive voltage drop results in low voltage to the load (contactor, relay) and then the transformer blows.

Here's what to look for:

- Transformer on the wrong voltage tap, i.e. 208 volts at the unit, transformer on the 230 volt tap.
- Voltage drop across contacts (measure with a load on the circuit): Voltage drop across contacts when load is applied should be less than 0.5 volt.

**Figure 122. Transformer chart**

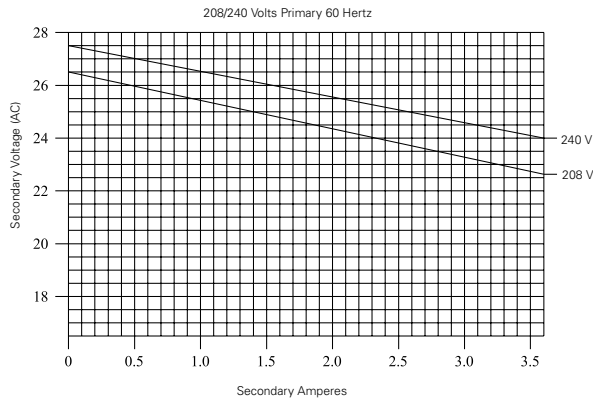

**Figure 123. Transformer troubleshooting**

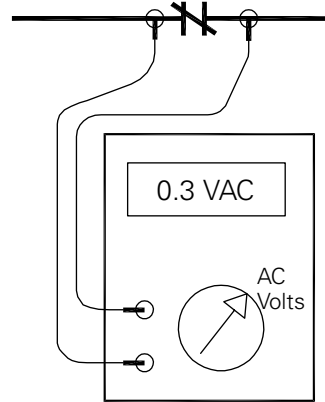

# Constant Volume (CV) and Variable Air Volume (VAV)

## Constant Volume (CV)

These units may use a conventional thermostat or zone sensor. The units can be controlled using a LonTalk® communications interface (LCI) or Tracer® Summit. Every unit comes with an RTRM and RTOM. All other circuit boards are optional depending upon unit configuration.

## Variable Air Volume (VAV)

VAV units use the same circuit boards as CV models, but operation and in some cases troubleshooting, are significantly different. The following sections contain operating and troubleshooting information on VAV units. Every unit comes with an RTRM, RTOM, and RTAM. Additional information can be found in the Installation, Operation, and Maintenance manual.

### VAV with ReliaTel™ versus VAV with UCP

ReliaTel™ units do everything UCP units did and more. Here are some differences between UCP and ReliaTel™ units:

- **VAV setpoint panel** – ReliaTel™ has the same setpoints as UCP but they are mounted on (and integral to) the RTAM module. Also, every setpoint can be provided remotely by clipping the appropriate jumper and using the terminal strip on the RTAM.
- **Exhaust fan setpoint panel** – ReliaTel™ exhaust fan setpoint potentiometer is located on the RTOM module in the main control box.
- **Zone sensor and NSB inputs** – With ReliaTel™, these inputs are located on the RTRM module instead of LTB1 (UCP).

*Note: The thermostat inputs on the RTRM are ignored. These inputs are for CV units only.*

- **Emergency stop** – This input, called ESTOP, is located on LTB1-5 and LTB1-6 instead of LTB1-16 and LTB1-17 (UCP).
- ReliaTel™ modules communicate with each other on a ModBus link. Each module has a status LED indicating that the module is communicating with the link.

### RTRM - ReliaTel™ Refrigeration Module - (Standard)

This is the primary control module. It has built-in terminal strips for zone sensor, thermostat, and night setback connections as well as diagnostic outputs for service. In addition, the RTRM has the following inputs and outputs:

- Compressor outputs
- Outdoor fan relay outputs
- Low pressure (LPC) inputs
- Outdoor air sensor (OAT) input
- Supply fan output

- Electric heat outputs (TE\* only)
- TEST mode input
- Emergency stop input

*Note: There is only one module used for 27.5 to 50 ton units regardless of configuration (VAV, CV). The unit is configured by wire harness inputs. See the unit wiring diagram for details.*

### RTOM - ReliaTel™ Options Module - (Standard)

This module has inputs for the following:

- Ventilation override (LTB4)
- Frostat™ input
- Clogged filter switch (optional)
- Discharge air sensor (optional on CV, standard on VAV)

*Note: Discharge air sensor required with CCP/ICS.*

### RTAM - ReliaTel™ Air Handler Module - (Standard on VAV)

This module contains the VAV setpoint potentiometers as well as the following inputs and outputs:

- DIP switch inputs for supply air reset, daytime warm-up enable, and IGV/VFD configuration.
- Supply pressure transducer input inlet guide vane (IGV) or variable frequency drive (VFD) output.
- Ventilation heat relay (VHR) output.

### ECA or RTEM - Economizer Actuator - (Optional)

If the unit has an economizer this module is present. It is screwed to the top of the economizer actuator motor in the economizer section of the unit. The ECA or RTEM has the following inputs and outputs:

- Mixed air sensor - this sensor is located in the supply air section of the unit.
- Return air sensor (optional) - This sensor is used when the unit has comparative enthalpy.
- Return humidity sensor (optional) - this sensor is used when the unit has comparative enthalpy.
- Outdoor humidity sensor (optional) - this sensor is used when the unit has reference enthalpy or comparative enthalpy.
- Exhaust fan relay output.
- CO<sub>2</sub> sensor input (optional).
- Remote minimum position potentiometer (optional).

## Constant Volume (CV) and Variable Air Volume (VAV)

### TCl - Trane® Communication Interface - (Optional)

Input and output for communication to Tracer® Summit (COMM4) or CCP (COMM4).

**Note:** ReliaTel™ TCI does support communication from earlier versions of Tracker®, Tracer® 100 or ComforTrac™.

### LCI - LonTalk® Communication Interface (optional)

Input and output for LON communication with Tracer® Summit, Tracker® Version 10+, or 3rd party LonTalk® building management systems.

### IGN - Ignition Control Module (YC\* only)

This module has the following inputs and outputs:

- TCO 1, TCO 2, TCO 3 input (limit switches).
- Hot Surface Ignitor output / flame sensor input.
- Combustion blower motor output.
- Gas valve output.

### Configuration Input

**Note:** The unit is hard wired with specific inputs as indicated below. These inputs cause the unit to respond with the appropriate outputs. Configuration inputs are only recognized at unit power-up.

Where “GND” is indicated below, the input is connected to chassis ground. Where “JUMPER” is indicated below, both connection points are shown.

| Unit                                  | RTOM J3-5 | RTRM J1-3,J1-5 |
|---------------------------------------|-----------|----------------|
| Voyager™ Commercial                   | GND       |                |
| Voyager™ Light Commercial, Precedent™ | Open      |                |
| Non Heat Pump                         |           | Jumper         |

| Cond Fan Cycling | RTOM J3-4 |
|------------------|-----------|
| 27.5 to 30 Tons  | GND       |
| 35 Ton           | Open      |
| 40 Ton           | GND       |
| 50 Ton           | Open      |

| SA Tempering (CV Units Only) | RTOMJ3-1,J3-2 |
|------------------------------|---------------|
| Enabled                      | Open          |
| Disabled                     | Jumper        |

| Electric Heat | RTRM J2-1,J2-2 |
|---------------|----------------|
| Heat          | Open           |
| No Heat       | Jumper         |

| 3 Compressor    | RTRM J3-7 |
|-----------------|-----------|
| 27.5 to 35 Tons | Open      |
| 40 to 50 Tons   | GND       |

| Lead/Lag | RTRM J3-8 |
|----------|-----------|
| Disabled | GND       |
| Enabled  | Open      |

| Modulating Gas    | RTOM J3-3 |
|-------------------|-----------|
| No Modulating Gas | Open      |
| Modulating Gas    | Ground    |

| High Heat (2 Heat Exchangers) | IGN #2 J1-5 |
|-------------------------------|-------------|
| High Heat                     | Ground      |

Unit functions are determined by the inputs on RTRM J6 as follows. The possible inputs are shown in the top (horizontal) row. The functions available are shown in the vertical columns below each input.

**Table 123. VAV default mode input**

|   | No Inputs on RTRM J6 | Jumper RTRM J6-2&4 | BAYSENS077* w/ RTRM J6-2&4 Jumper | BAYSENS021* or BAYSENS077* w/7.68k resistor between RTRM J6-2&4 | BAYSENS020* or ICS™ system (Tracer® Summit) |
|---|----------------------|--------------------|-----------------------------------|---|---|
| Occupied Cooling  | No                   | Yes                | Yes                               | Yes   | Yes   |
| Daytime Warm-up   | No                   | No                 | Yes                               | Yes   | Yes   |
| Morning Warm-up   | No                   | No                 | Yes                               | Yes   | Yes   |
| Indoor Blower (occupied mode)   | Off                  | On                 | On                                | On  | On  |
| Indoor Blower (unoccupied mode)                                       | N/A                  | Off                | Auto                              | Auto  | Auto  |
| Unoccupied Cooling  | N/A                  | No                 | No                                | No  | Yes   |
| Unoccupied Heating  | N/A                  | No                 | Yes                               | Yes   | Yes   |
| Short Across RTRM J6-11&12 creates an unoccupied mode (Night setback) | No                   | No                 | Yes                               | Yes   | N/A   |

Note: \* Means 'B' or 'C'

### Supply Duct Static Pressure Control

The supply duct static pressure is measured by using a 0 to 5 Vdc transducer. The transducer is mounted on the supply fan bulkhead on the motor side of the supply fan section. The transducer is comparing the supply duct pressure (actually the pressure of the heat section of the unit) to outdoor air pressure. The high port of the transducer is connected to the static pressure sensing cover plate located on the supply fan bulkhead. The low port of the transducer is connected to a tubing connector on a vertical support of the unit and is field-connected to the outside air pressure sensor as pictured below. The transducer is wired to the RTAM and the decision to modulate the IG V or VFD is made at the RTRM.

### Modes of Operation

Setpoints are provided by using the potentiometers on the RTAM, through remote potentiometers, or through ICS. The setpoint range is 0.3 in. wc to 2.5 in. wc. The deadband range is 0.2 in. wc to 1.0 in. wc.

The control band is the setpoint plus or minus 0.5 of the deadband.

| Example   |                           |
|---|---------------------------|
| Setpoint  | 1.5 inches                |
| Deadband  | 0.4 inches                |
| The IG V or VFD output will increase if the supply pressure goes below      | 1.3 inches                |
| The IG V or VFD output will decrease if the supply pressure goes above      | 1.7 inches                |
| The IG V or VFD output will not change if the supply pressure stays between | 1.3 inches and 1.7 inches |

DIP switch settings for this function are as follows:

- RTAM SW1 switch 1 OFF for IG V, ON for VFD.
- RTAM SW1 switch 2 OFF for VAV, ON for VAV without IG V.

**Figure 124. Supply duct static pressure control**

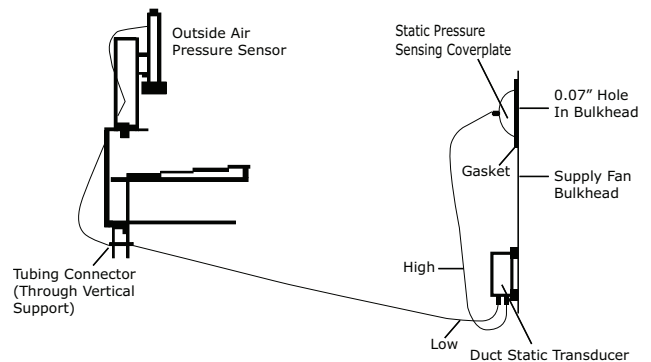

## Constant Volume (CV) and Variable Air Volume (VAV)

Figure 125. Transducer voltage output vs. pressure

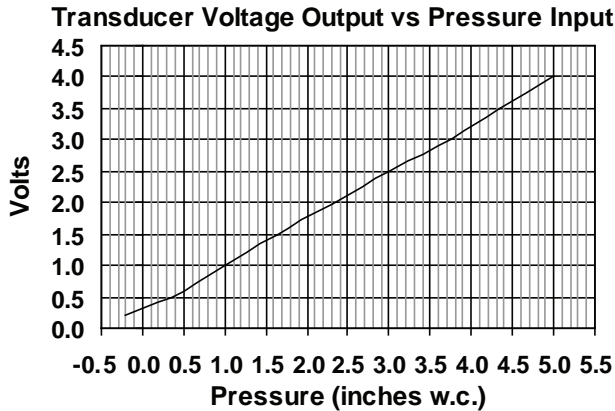

The transducer has a 0 to 5 Vdc range with a 0.25 to 2.125 Vdc valid output range. The output is proportional. The chart illustrates the measured output voltage at typical supply duct pressures.

### VHR Relay

When the unit transitions from occupied mode to morning warm-up, daytime warm-up or unoccupied mode, the VHR relay is energized, as long as the unit has a valid zone temperature input at RTRM J6 1&2, or through a BAYSENS020\* zone sensor.

Figure 126. VHR relay

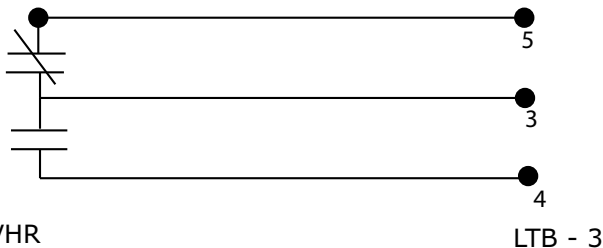

The VHR relay has a set of contacts on TB3 for the purpose of commanding the VAV boxes to drive open to maximum airflow position.

If the unit has heat, the VAV boxes must be driven open. If the boxes are allowed to stay in control, the boxes may try to close instead of open when the warm air enters the room.

- When RTAM DIP SW1-1 is on, the output voltage range is approximately 0 to 10.5 Vdc.
- When RTAM DIP SW1-1 is off, the output voltage range is approximately 2.5 to 8.5 Vdc.
- IGV: When the supply fan is on and the output is 0%, the IGV are closed.
- VFD: When the supply fan is on and the output is 0%, the VFD runs at 35 Hz.
- If the supply static pressure goes below -0.2 inch (0.2 Vdc) the IGV / VFD output will stay at 0% and the

diagnostic COOL FAIL + SERVICE FAIL will be present.

- If the static pressure exceeds 3.8 in. wc the supply fan will stop and the diagnostic HEAT FAIL + COOL FAIL + SERVICE FAIL will be present.
- During the heating modes; Daytime warm-up, morning warm-up, and unoccupied, the IGV or VFD output is always 100%.

### Troubleshooting Tips

If the transducer output voltages do not seem right, connect a 0-5" manometer in parallel with the transducer. This way you can see the same pressure the transducer is seeing. Many transducers get replaced in error when the real culprit is a loose tube or clogged fitting.

The polyethylene tubing in the transducer circuit does not readily go back to its original shape after use. If a tube is removed from a fitting it should be cut back to a fresh end prior to reattaching.

Measure the transducer output voltage at RTAM terminal J1-3 to chassis ground.

When the supply fan is off, the transducer output voltage should be approximately 0.25 Vdc. If the voltage output is high or low, unplug the transducer tubing to see if the voltage increases or decreases. If it does, a tube is probably clogged.

The input voltage to the transducer is measured between RTAM J1-4 and chassis ground. It should be 5 Vdc. If it is low, unplug the transducer and measure the voltage again. If OK now, the transducer or transducer wiring is shorted to common or ground.

The outdoor air pressure sensor must be mounted as shown in Figure 124, p. 185. If the sensor is mounted upside down the tubing can fill with water during heavy rains.

The static pressure sensing cover plate in the fan section of the unit is bolted to the fan bulkhead. The bulkhead has a very small (0.07 inches) hole in the center area. The purpose of using such a small hole is to ensure that the transducer only sees the average supply air pressure. If the hole is enlarged, the transducer could respond erratically. If the hole is plugged, the transducer will not respond. If the gasket between the cover plate and bulkhead is leaking, the supply pressure will appear to be abnormally low since the cover plate is in the fan section.

### Application Notes

Some applications call for relocating the supply air tube to 2/3 of the way down the duct. If this is done, be certain that there is no potential obstruction between the unit and the pickup point (such as fire dampers). A separate high duct static switch may need to be added.

The outside air pressure sensor should be located on top of the unit as shown in Figure 124, p. 185. Some applications with extreme winds could require mounting the sensor in an area less affected by wind.

### BAYSENS021\* Setpoint Input

This chart lists setpoint/voltage/resistance for the VAV supply air cooling setpoint on the RTRM module. The chart can be used for troubleshooting units that have a remote setpoint at this input.

The typical remote setpoint input device is a BAYSENS021\* zone sensor.

The connection points are RTRM J6-2 and RTRM J6-3.

If a remote setpoint is used, clip jumper R69 on the RTAM module. If the jumper is not clipped, the unit will ignore the RTRM setpoint.

**Note:** A remote setpoint can also be applied to the RTAM supply air cooling setpoint input. The RTAM inputs use different temperature/resistance inputs. See VAV setpoint inputs for input values.

**Table 124. Supply air cooling setpoint**

| Supply Air Cooling Setpoint (°F) | Resistance (ohms) | DC Volts |
|----------------------------------|-------------------|----------|
| 40                               | 1084              | 2.6      |
| 41                               | 1065              | 2.58     |
| 42                               | 1045              | 2.56     |
| 43                               | 1026              | 2.53     |
| 44                               | 1006              | 2.51     |
| 45                               | 987               | 2.48     |
| 46                               | 967               | 2.46     |
| 47                               | 948               | 2.43     |
| 48                               | 928               | 2.41     |
| 49                               | 909               | 2.38     |
| 50                               | 889               | 2.35     |
| 51                               | 870               | 2.33     |
| 52                               | 850               | 2.3      |
| 53                               | 831               | 2.27     |
| 54                               | 812               | 2.24     |
| 55                               | 792               | 2.21     |
| 56                               | 773               | 2.18     |
| 57                               | 753               | 2.15     |
| 58                               | 734               | 2.12     |
| 59                               | 714               | 2.08     |
| 60                               | 695               | 2.05     |
| 61                               | 675               | 2.02     |
| 62                               | 656               | 1.98     |
| 63                               | 636               | 1.94     |
| 64                               | 617               | 1.91     |
| 65                               | 597               | 1.87     |
| 66                               | 578               | 1.83     |
| 67                               | 558               | 1.79     |
| 68                               | 539               | 1.75     |
| 69                               | 519               | 1.71     |
| 70                               | 500               | 1.67     |
| 71                               | 481               | 1.62     |
| 72                               | 461               | 1.58     |
| 73                               | 442               | 1.53     |
| 74                               | 422               | 1.48     |
| 75                               | 403               | 1.44     |
| 76                               | 383               | 1.39     |
| 77                               | 364               | 1.33     |
| 78                               | 344               | 1.28     |
| 79                               | 325               | 1.23     |
| 80                               | 305               | 1.17     |

This chart lists setpoint/voltage/resistance for VAV setpoints on the RTAM module in the control compartment. The chart can be used for troubleshooting the RTAM module or for applying a remote setpoint to the unit.

Each setpoint can be provided remotely by applying the appropriate resistance as shown in the table after cutting the resistor next to the setpoint knob. See .

### Remote Setpoint Inputs on RTAM J7

**Table 125. Remote setpoint inputs**

|       |                                |
|-------|--------------------------------|
| J7-1  | 2 Supply air pressure setpoint |
| J7-3  | 4 Supply air cooling setpoint  |
| J7-5  | 6 Supply air reset amount      |
| J7-7  | 8 Supply air pressure deadband |
| J7-9  | 10 Morning warm-up setpoint    |
| J7-11 | 12 Supply air reset setpoint   |
| J7-13 | 14 Supply air heating setpoint |

**Figure 127. RTAM module**

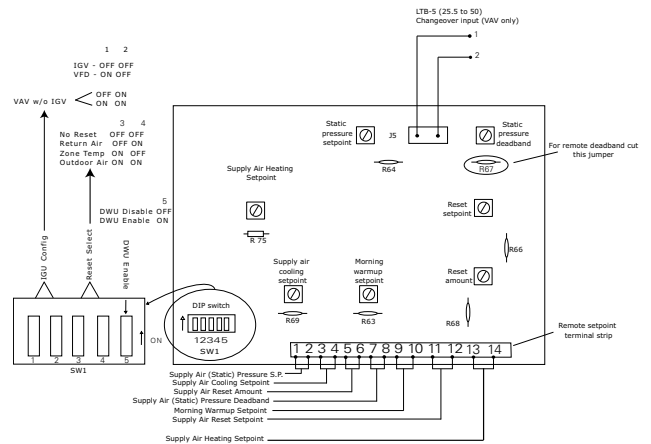

For remote setpoint cut this jumper:

- Supply air pressure setpoint R64
- Supply air cooling setpoint R69
- Supply air heating setpoint R75
- Supply air reset amount R68
- Supply air pressure Deadband R67
- Morning warm-up setpoint R63
- Supply air reset setpoint R66

**Note:** Remote SA cooling setpoint can be installed on RTAM J7-3, 4 (as shown) or on RTRM J6-2, 3. If the SA Cooling setpoint is installed on RTRM J6-2, 3 or a BAYSENS021\* is being used; see VAV supply air cooling remote setpoint - BAYSENS021\*.

## Constant Volume (CV) and Variable Air Volume (VAV)

### Morning Warm-up:

- Is allowed even if DWU is disabled.
- Enabled by transition from unocc to occup (power reset, emergency reset will not do it).

### Supply Air Heating:

- 40-150°F +/- 2°F
- 5 minute changeover heat/cool input
- Changeover input required

### Unoccupied Heating:

- Is allowed even if DWU is disabled

**Table 126. VAV setpoints**

|                   |          | Supply Air Pressure Setpoint | Supply Air Cooling Setpoint | Supply Air Reset Amount | Supply Air Pressure Deadband | Morning Warm-up Setpoint | Supply Air Reset Setpoint Outdoor | Supply Air Reset Setpoint Zone or Return Air | RTAM Supply Air Heat Setpoint |
|-------------------|----------|------------------------------|-----------------------------|-------------------------|------------------------------|--------------------------|-----------------------------------|--|-------------------------------|
|                   |          | J7-1,2                       | J7-3,4                      | J7-5,6                  | J7-7,8                       | J7-9,10                  | J7-11,12                          | J7-11,12                                     | J7 - 13, 14                   |
| Resistance (Ohms) | DC Volts | WC                           | Deg F                       | Deg F                   | WC                           | Deg F                    | Deg F                             | Deg F  | Deg F                         |
| 0                 | 0        | 0                            | 40                          | 0                       | 0                            | 50                       | 0                                 | 50   | 40                            |
| 10                | 0.05     | 0.02                         | 40.27                       | 0.13                    | 0.01                         | 50.27                    | 0.67                              | 50.27  | 40.7                          |
| 20                | 0.1      | 0.05                         | 40.81                       | 0.4                     | 0.02                         | 50.81                    | 20.02                             | 50.81  | 42.2                          |
| 30                | 0.15     | 0.08                         | 41.29                       | 0.65                    | 0.03                         | 51.29                    | 3.23                              | 51.29  | 43.6                          |
| 40                | 0.19     | 0.11                         | 41.23                       | 0.91                    | 0.05                         | 51.23                    | 4.57                              | 51.83  | 45.1                          |
| 50                | 0.24     | 0.14                         | 42.31                       | 1.16                    | 0.06                         | 52.31                    | 5.78                              | 52.31  | 46.4                          |
| 60                | 0.28     | 0.17                         | 42.79                       | 1.4                     | 0.07                         | 52.79                    | 6.99                              | 52.79  | 47.8                          |
| 70                | 0.33     | 0.2                          | 43.28                       | 1.64                    | 0.08                         | 53.28                    | 8.19                              | 53.28  | 49.1                          |
| 80                | 0.37     | 0.24                         | 43.76                       | 1.88                    | 0.09                         | 53.76                    | 9.4                               | 53.76  | 50.4                          |
| 90                | 0.41     | 0.27                         | 44.24                       | 2.12                    | 0.11                         | 54.24                    | 10.61                             | 54.24  | 51.8                          |
| 100               | 0.45     | 0.3                          | 44.73                       | 2.36                    | 0.12                         | 54.73                    | 11.82                             | 54.73  | 53.1                          |
| 110               | 0.5      | 0.32                         | 45.16                       | 2.58                    | 0.13                         | 55.16                    | 12.89                             | 55.16  | 54.3                          |
| 120               | 0.54     | 0.35                         | 45.59                       | 2.79                    | 0.14                         | 55.59                    | 13.97                             | 55.59  | 55.5                          |
| 130               | 0.58     | 0.38                         | 46.02                       | 3.01                    | 0.15                         | 56.02                    | 15.04                             | 56.02  | 56.7                          |
| 140               | 0.61     | 0.4                          | 46.45                       | 3.22                    | 0.16                         | 56.45                    | 16.12                             | 56.45  | 57.9                          |
| 150               | 0.65     | 0.43                         | 46.88                       | 3.44                    | 0.17                         | 56.88                    | 17.19                             | 56.88  | 59.1                          |
| 160               | 0.69     | 0.46                         | 47.31                       | 3.65                    | 0.18                         | 57.31                    | 18.26                             | 57.31  | 60.3                          |
| 170               | 0.73     | 0.48                         | 47.68                       | 3.84                    | 0.19                         | 57.68                    | 19.2                              | 57.68  | 61.3                          |
| 180               | 0.76     | 0.51                         | 48.11                       | 4.06                    | 0.2                          | 58.11                    | 20.28                             | 58.11  | 62.5                          |
| 190               | 0.8      | 0.53                         | 48.49                       | 4.24                    | 0.21                         | 58.49                    | 21.22                             | 58.49  | 63.6                          |
| 200               | 0.83     | 0.55                         | 48.86                       | 4.43                    | 0.22                         | 58.86                    | 22.16                             | 58.86  | 64.6                          |
| 210               | 0.87     | 0.58                         | 49.24                       | 4.62                    | 0.23                         | 59.24                    | 23.1                              | 59.24  | 65.7                          |
| 220               | 0.9      | 0.6                          | 49.62                       | 4.81                    | 0.24                         | 59.62                    | 24.04                             | 59.62  | 66.7                          |
| 230               | 0.93     | 0.62                         | 49.99                       | 5                       | 0.25                         | 59.99                    | 24.98                             | 59.99  | 67.8                          |
| 240               | 0.97     | 0.65                         | 50.37                       | 5.18                    | 0.26                         | 60.37                    | 25.92                             | 60.37  | 68.8                          |
| 250               | 1        | 0.67                         | 50.69                       | 5.34                    | 0.27                         | 60.69                    | 26.72                             | 60.69  | 69.7                          |
| 260               | 1.03     | 0.7                          | 51.26                       | 5.63                    | 0.28                         | 61.26                    | 28.14                             | 61.26  | 71.3                          |
| 270               | 1.06     | 0.73                         | 51.74                       | 5.87                    | 0.29                         | 61.74                    | 29.35                             | 61.74  | 72.6                          |
| 280               | 1.09     | 0.77                         | 52.3                        | 6.15                    | 0.31                         | 62.3                     | 30.76                             | 62.3   | 74.2                          |
| 290               | 1.12     | 0.8                          | 52.79                       | 6.39                    | 0.32                         | 62.79                    | 31.97                             | 62.79  | 75.5                          |
| 300               | 1.15     | 0.83                         | 53.27                       | 6.63                    | 0.33                         | 63.27                    | 33.17                             | 63.27  | 76.9                          |
| 310               | 1.18     | 0.86                         | 53.75                       | 6.88                    | 0.34                         | 63.75                    | 34.38                             | 63.75  | 78.2                          |
| 320               | 1.21     | 0.89                         | 54.24                       | 7.12                    | 0.36                         | 64.24                    | 35.59                             | 64.24  | 79.5                          |
| 330               | 1.24     | 0.92                         | 54.72                       | 7.36                    | 0.37                         | 64.72                    | 36.8                              | 64.72  | 80.9                          |
| 340               | 1.27     | 0.95                         | 55.12                       | 7.56                    | 0.38                         | 65.12                    | 37.81                             | 65.12  | 82                            |
| 350               | 1.3      | 0.98                         | 55.61                       | 7.8                     | 0.39                         | 65.61                    | 39.01                             | 65.61  | 83.3                          |
| 360               | 1.32     | 1.01                         | 56.09                       | 8.04                    | 0.4                          | 66.09                    | 40.22                             | 66.09  | 84.7                          |
| 370               | 1.35     | 1.03                         | 56.49                       | 8.25                    | 0.41                         | 66.49                    | 41.23                             | 66.49  | 85.8                          |
| 380               | 1.38     | 1.06                         | 56.89                       | 8.45                    | 0.42                         | 66.89                    | 42.24                             | 66.89  | 86.9                          |
| 390               | 1.4      | 1.09                         | 57.38                       | 8.69                    | 0.43                         | 67.38                    | 43.45                             | 67.38  | 88.3                          |
| 400               | 1.43     | 1.11                         | 57.78                       | 8.89                    | 0.44                         | 67.78                    | 44.45                             | 67.78  | 89.4                          |
| 410               | 1.45     | 1.14                         | 58.18                       | 9.09                    | 0.45                         | 68.18                    | 45.46                             | 68.18  | 90.5                          |
| 420               | 1.48     | 1.16                         | 58.59                       | 9.29                    | 0.46                         | 68.59                    | 46.47                             | 68.59  | 91.6                          |
| 430               | 1.5      | 1.19                         | 58.99                       | 9.49                    | 0.47                         | 68.99                    | 47.47                             | 68.99  | 92.7                          |
| 440               | 1.53     | 1.21                         | 59.39                       | 9.7                     | 0.48                         | 69.39                    | 48.48                             | 69.39  | 93.9                          |
| 450               | 1.55     | 1.24                         | 59.8                        | 9.9                     | 0.49                         | 69.8                     | 49.49                             | 69.8   | 95                            |



## Constant Volume (CV) and Variable Air Volume (VAV)

**Table 126. VAV setpoints (continued)**

|                   |          | Supply Air Pressure Setpoint | Supply Air Cooling Setpoint | Supply Air Reset Amount | Supply Air Pressure Deadband | Morning Warm-up Setpoint | Supply Air Reset Setpoint Outdoor | Supply Air Reset Setpoint Zone or Return Air | RTAM Supply Air Heat Setpoint |
|-------------------|----------|------------------------------|-----------------------------|-------------------------|------------------------------|--------------------------|-----------------------------------|--|-------------------------------|
|                   |          | J7-1,2                       | J7-3,4                      | J7-5,6                  | J7-7,8                       | J7-9,10                  | J7-11,12                          | J7-11,12                                     | J7 - 13, 14                   |
| Resistance (Ohms) | DC Volts | WC                           | Deg F                       | Deg F                   | WC                           | Deg F                    | Deg F                             | Deg F  | Deg F                         |
| 460               | 1.58     | 1.26                         | 60.2                        | 10.1                    | 0.5                          | 70.2                     | 50.5                              | 70.2   | 96.1                          |
| 470               | 1.6      | 1.29                         | 60.6                        | 10.3                    | 0.52                         | 70.6                     | 51.5                              | 70.6   | 97.2                          |
| 480               | 1.62     | 1.31                         | 61                          | 10.5                    | 0.53                         | 71                       | 52.51                             | 71   | 98.3                          |
| 490               | 1.64     | 1.33                         | 61.33                       | 10.66                   | 0.53                         | 71.33                    | 53.32                             | 71.33  | 99.2                          |
| 500               | 1.67     | 1.36                         | 61.73                       | 10.86                   | 0.54                         | 71.73                    | 54.32                             | 71.73  | 100.4                         |
| 510               | 1.69     | 1.39                         | 62.25                       | 11.12                   | 0.56                         | 72.25                    | 55.62                             | 72.25  | 101.8                         |
| 520               | 1.71     | 1.43                         | 62.81                       | 11.41                   | 0.57                         | 72.81                    | 57.03                             | 72.81  | 103.4                         |
| 530               | 1.73     | 1.45                         | 63.26                       | 11.63                   | 0.58                         | 73.26                    | 58.16                             | 73.26  | 104.6                         |
| 540               | 1.75     | 1.49                         | 63.83                       | 11.91                   | 0.6                          | 73.83                    | 59.57                             | 73.83  | 106.2                         |
| 550               | 1.77     | 1.52                         | 64.28                       | 12.14                   | 0.61                         | 74.28                    | 60.7                              | 74.28  | 107.4                         |
| 560               | 1.79     | 1.55                         | 64.73                       | 12.36                   | 0.62                         | 74.73                    | 61.82                             | 74.73  | 108.7                         |
| 570               | 1.82     | 1.57                         | 65.18                       | 12.59                   | 0.63                         | 75.18                    | 62.95                             | 75.18  | 109.9                         |
| 580               | 1.84     | 1.6                          | 65.63                       | 12.82                   | 0.64                         | 75.63                    | 64.08                             | 75.63  | 111.2                         |
| 590               | 1.86     | 1.63                         | 66.08                       | 13.04                   | 0.65                         | 76.08                    | 65.21                             | 76.08  | 112.5                         |
| 600               | 1.88     | 1.67                         | 66.65                       | 13.32                   | 0.67                         | 76.65                    | 66.62                             | 76.65  | 114                           |
| 610               | 1.89     | 1.69                         | 66.99                       | 13.49                   | 0.67                         | 76.99                    | 67.46                             | 76.99  | 115                           |
| 620               | 1.91     | 1.71                         | 67.44                       | 13.72                   | 0.69                         | 77.44                    | 68.59                             | 77.44  | 116.2                         |
| 630               | 1.93     | 1.74                         | 67.89                       | 13.94                   | 0.7                          | 77.89                    | 69.72                             | 77.89  | 117.5                         |
| 640               | 1.95     | 1.77                         | 68.34                       | 14.17                   | 0.71                         | 78.34                    | 70.85                             | 78.34  | 118.7                         |
| 650               | 1.97     | 1.8                          | 68.79                       | 14.4                    | 0.72                         | 78.79                    | 71.98                             | 78.79  | 120                           |
| 660               | 1.99     | 1.83                         | 69.24                       | 14.62                   | 0.73                         | 79.24                    | 73.1                              | 79.24  | 121.2                         |
| 670               | 2.01     | 1.85                         | 69.58                       | 14.79                   | 0.74                         | 79.58                    | 73.95                             | 79.58  | 122.2                         |
| 680               | 2.02     | 1.88                         | 70.03                       | 15.02                   | 0.75                         | 80.03                    | 75.08                             | 80.03  | 123.4                         |
| 690               | 2.04     | 1.91                         | 70.48                       | 15.24                   | 0.76                         | 80.48                    | 76.21                             | 80.48  | 124.7                         |
| 700               | 2.06     | 1.93                         | 70.82                       | 15.41                   | 0.77                         | 80.82                    | 77.05                             | 80.82  | 125.6                         |
| 710               | 2.08     | 1.95                         | 71.27                       | 15.64                   | 0.78                         | 81.27                    | 78.18                             | 81.27  | 126.9                         |
| 720               | 2.09     | 1.98                         | 71.61                       | 15.81                   | 0.79                         | 81.61                    | 79.03                             | 81.61  | 127.8                         |
| 730               | 2.11     | 2                            | 72.06                       | 16.03                   | 0.8                          | 82.06                    | 80.15                             | 82.06  | 129.1                         |
| 740               | 2.13     | 2.02                         | 72.4                        | 16.2                    | 0.81                         | 82.4                     | 81                                | 82.4   | 130                           |
| 750               | 2.14     | 2.05                         | 72.74                       | 16.37                   | 0.82                         | 82.74                    | 81.85                             | 82.74  | 130.9                         |
| 760               | 2.16     | 2.08                         | 73.29                       | 16.65                   | 0.83                         | 83.29                    | 83.23                             | 83.29  | 132.5                         |
| 770               | 2.18     | 2.11                         | 73.75                       | 16.87                   | 0.84                         | 83.75                    | 84.36                             | 83.75  | 133.7                         |
| 780               | 2.19     | 2.14                         | 74.2                        | 17.1                    | 0.85                         | 84.2                     | 85.49                             | 84.2   | 135                           |
| 790               | 2.21     | 2.17                         | 74.65                       | 17.32                   | 0.87                         | 84.65                    | 86.62                             | 84.65  | 136.2                         |
| 800               | 2.22     | 2.2                          | 75.25                       | 17.62                   | 0.88                         | 85.25                    | 88.12                             | 85.25  | 137.9                         |
| 810               | 2.24     | 2.23                         | 75.7                        | 17.85                   | 0.89                         | 85.7                     | 89.25                             | 85.7   | 139.2                         |
| 820               | 2.25     | 2.26                         | 76.15                       | 18.08                   | 0.9                          | 86.15                    | 90.38                             | 86.15  | 140.4                         |
| 830               | 2.27     | 2.29                         | 76.6                        | 18.3                    | 0.92                         | 86.6                     | 91.51                             | 86.6   | 141.7                         |
| 840               | 2.28     | 2.32                         | 77.05                       | 18.53                   | 0.93                         | 87.05                    | 92.63                             | 87.05  | 142.9                         |
| 850               | 2.3      | 2.34                         | 77.5                        | 18.75                   | 0.94                         | 87.5                     | 93.76                             | 87.5   | 144.2                         |
| 860               | 2.31     | 2.37                         | 77.96                       | 18.98                   | 0.95                         | 87.96                    | 94.89                             | 87.96  | 145.4                         |
| 870               | 2.33     | 2.4                          | 78.41                       | 19.2                    | 0.96                         | 88.41                    | 96.02                             | 88.41  | 146.7                         |
| 880               | 2.34     | 2.43                         | 78.86                       | 19.43                   | 0.97                         | 88.86                    | 97.15                             | 88.86  | 147.9                         |
| 890               | 2.35     | 2.46                         | 79.31                       | 19.65                   | 0.98                         | 89.31                    | 98.27                             | 89.31  | 149.2                         |
| 900               | 2.37     | 2.49                         | 79.76                       | 19.88                   | 0.99                         | 89.76                    | 99.4                              | 89.76  | 150                           |
| 910               | 2.38     | 2.5                          | 80                          | 20                      | 1                            | 90                       | 100                               | 90   | 150                           |
| 920               | 2.4      | 2.5                          | 80                          | 20                      | 1                            | 90                       | 100                               | 90   | 150                           |
| 930               | 2.41     | 2.5                          | 80                          | 20                      | 1                            | 90                       | 100                               | 90   | 150                           |
| 940               | 2.42     | 2.5                          | 80                          | 20                      | 1                            | 90                       | 100                               | 90   | 150                           |
| 950               | 2.44     | 2.5                          | 80                          | 20                      | 1                            | 90                       | 100                               | 90   | 150                           |
| 960               | 2.45     | 2.5                          | 80                          | 20                      | 1                            | 90                       | 100                               | 90   | 150                           |
| 970               | 2.46     | 2.5                          | 80                          | 20                      | 1                            | 90                       | 100                               | 90   | 150                           |
| 980               | 2.47     | 2.5                          | 80                          | 20                      | 1                            | 90                       | 100                               | 90   | 150                           |
| 990               | 2.49     | 2.5                          | 80                          | 20                      | 1                            | 90                       | 100                               | 90   | 150                           |

## Constant Volume (CV) and Variable Air Volume (VAV)

Table 126. VAV setpoints (continued)

|                   |          | Supply Air Pressure Setpoint | Supply Air Cooling Setpoint | Supply Air Reset Amount | Supply Air Pressure Deadband | Morning Warm-up Setpoint | Supply Air Reset Setpoint Outdoor | Supply Air Reset Setpoint Zone or Return Air | RTAM Supply Air Heat Setpoint |
|-------------------|----------|------------------------------|-----------------------------|-------------------------|------------------------------|--------------------------|-----------------------------------|--|-------------------------------|
|                   |          | J7-1,2                       | J7-3,4                      | J7-5,6                  | J7-7,8                       | J7-9,10                  | J7-11,12                          | J7-11,12                                     | J7 - 13, 14                   |
| Resistance (Ohms) | DC Volts | WC                           | Deg F                       | Deg F                   | WC                           | Deg F                    | Deg F                             | Deg F  | Deg F                         |
| 1000              | 2.5      | 2.5                          | 80                          | 20                      | 1                            | 90                       | 100                               | 90   | 150                           |

**Notes:**

1. Supply air pressure setpoint valid range is 0.3"-2.5".
2. Supply air pressure deadband valid range is 0.2"-1".

### MZVAV Morning/Daytime Warm-up

#### Morning Warm-up

Morning warm-up (MWU) is only available on units configured as MZVAV configured with heat (staged mechanical, staged electric, staged gas, modulating gas) and with valid space temperature reading (hardwired or BAS supplied).

MWU can be configured and enabled/disabled through BAS. MWU only occurs when the unit is transitioning from unoccupied to optimal start or occupied. If the space temperature is 1.5°F below the morning warm-up setpoint (set by the RTAM or supplied by BAS), MWU is initiated, and the economizer damper is driven closed. Once MWU is active, the supply fan will ramp to its minimum speed and the VHR relay will be energized. The unit remains in this mode for 6 minutes. At the end of the 6 minute time delay, the fan will ramp to 100% and the heat will stage up to 100%. MWU remains active until the space temperature is equal to or greater than the MWU setpoint or for one hour. Once MWU terminates, the unit will transition to VAV cooling mode.

#### Daytime Warm-up

Daytime warm-up (DWU) is only available on units configured as MZVAV configured with heat (staged mechanical, staged electric, staged gas, modulating gas) and with valid space temperature reading (hardwired or BAS supplied).

DWU can be configured and enabled/disabled through BAS or with RTAM SW1-5 set to On. DWU occurs during occupied periods when the space temperature is less than the daytime warm-up initiate setpoint (BAS) or 3°F below the MWU setpoint (RTAM). Once DWU is active, the economizer will modulate to the minimum setpoint, the supply fan will ramp to its minimum speed and the VHR relay will be energized. The unit remains in this mode for 6 minutes. At the end of the 6 minute time delay, the fan will ramp to 100% and the heat will stage up to 100%. DWU remains active until the space temperature is equal to or greater than the daytime warm-up terminate setpoint (BAS) or MWU setpoint. Once DWU terminates, the unit will transition to VAV cooling mode.

### VHR Relay

MZVAV units operating in MWU, DWU or in unoccupied modes will operate as a constant volume unit (CV). When the unit is in a CV mode, it is necessary to for the VAV boxes installed with the unit to open their dampers to their max airflow position to prevent high static issues or high temperature issues when heating. All MZVAV configured units are equipped with a VHR relay. This relay is energized anytime the unit is in MWU, DWU or is unoccupied. The purpose of the VHR relay is to provide a hardwired set of contacts to signal VAV boxes to drive open during MWU, DWU or unoccupied periods. The VHR relay is wired to the unit LTB with a set of normally open (NO) and normally closed (NC) dry contacts. The status of the VHR can also be monitored through BAS and should be used to coordinate the VAV boxes accordingly.

### MZVAV Unoccupied Heating/Cooling

#### MZVAV in Local Mode (No BAS, No Programmable Zone Sensor)

Unoccupied heating is available on units with a zone sensor connected to RTRM J6-1 and 2 (unoccupied cooling is not available on MZVAV in local control). Shorting RTRM J6-11 to J6-12 will force the unit unoccupied. In unoccupied mode, the VHR Relay is energized, and unoccupied heating is available. The unoccupied heating setpoint is set to MWU setpoint minus 10°F or 50°F, whichever is greater. Unoccupied heating initiates when the space temp drops below the unoccupied heating setpoint. Unoccupied heating terminates when the space temp is greater that the unoccupied heating setpoint.

#### MZVAV with BAS or Programmable Zone Sensor

During unoccupied mode, the VHR relay is energized and the if the space temperature rises above the unoccupied cooling setpoint, the unit will initiate unoccupied cooling mode and operate as a constant volume unit. The supply fan will ramp to 100% and the cooling will stage up to satisfy space temperature. This includes economizer cooling if economizing conditions are met. Compressor

staging time delays are still observed in this mode. Unoccupied cooling terminates when the space temperature drops below the unoccupied cooling setpoint. At that time the unit will shut down. On BAS, unit will report **max heat**.

During unoccupied mode, if the space temperature drops below the unoccupied heating setpoint, the unit will initiate unoccupied heating mode and operate in a similar fashion as daytime/morning warmup. The VHR relay will already be energized, the supply fan will ramp to 100%, and the heat

will stage to 100%. Unoccupied heating terminates when the space temperature rises above the unoccupied heating setpoint. At this time the unit will shut down.

Demand limits, restricting available compressor capacity, are to have higher priority over the commanded compressor capacity staging level due to occupancy status.

Dehumidification is not supported on MZVAV at this time.

# Outdoor Airflow Compensation for MZVAV Units

## 3 to 50 Tons

When a VAV unit is modulating supply airflow, the pressure drop across the outdoor air damper changes. This usually means that the quantity of outside air will drop as the IGV closes or the VFD slows down. VAV units have a feature called outside air (OA) flow compensation to help maintain consistent OA flow regardless of supply airflow.

**Note:** OA flow compensation mode is disabled if the unit has a CO<sub>2</sub> sensor, min position input from ICS, or remote min position input at LTB3-1 and LTB3-2. It is also overridden during all ventilation override modes. Also, the minimum position can only be adjusted from 0 to 50% damper position regardless of OA flow setpoints.

### Setup

Once set up, the OA damper position will increase as the IGV closes or VFD slows down. The 27K resistor with plug in KIT#PLU00970 provides a signal to the unit to enable this function. The resistor must be plugged to the OAT input (this is an otherwise unused input) on the economizer module (ECA or RTEM) and power reset to the unit.

### Operation for RTRM 7.0 and Earlier with RTEM or Any RTRM with Honeywell ECA

The potentiometers MIN POS and DCV SETPOINT (DCV UL setpoint if RTEM) must now each be set in order to control the OA damper position. The MIN POS setpoint determines the OA damper position (from 0 to 50%) when the IGV/VFD is at 100% regardless of DCV SETPOINT (DCV UL Setpoint).

**Note:** This function is disabled if a building management system (ICS, Tracer®, LonTalk®) is providing a OA damper minimum position setpoint to the unit. This function is disabled if the unit is using a CO<sub>2</sub> sensor input at the DCV input or if a building management system (ICS, Tracer®, LonTalk®) is providing a CO<sub>2</sub> sensor input to the unit.

The DCV SETPOINT (DCV UL Setpoint) determines the percentage increase of the OA damper position when the IGV/VFD is at 0%. The percentage of OA damper increase between 0 and 100% IGV/VFD is linear. To have no effect on the OA damper position when the IGV/VFD output is 0%, set the DCV SETPOINT to 0%. To have the maximum effect on the OA damper position when the IGV/VFD output is 100%, set the DCV SETPOINT (DCV UL Setpoint) to 100%. This chart shows the effect of DCV input vs. MIN POS when the IGV/VFD is at 0%.

Figure 128. Outdoor airflow compensation

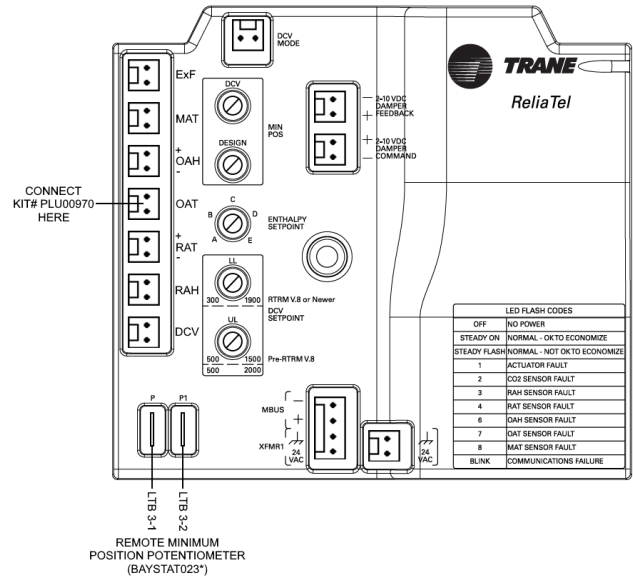

Table 127. OA damper minimum position when IGV is closed /VFD at min. HZ

|                           | MIN POS<br>0% (CCW) | MIN POS<br>25% | MIN POS<br>50% (CW) |
|---------------------------|---------------------|----------------|---------------------|
| DCVSP (DCV UL SP) 0%      | 0 (closed)          | 25%            | 50%                 |
| DCVSP (DCV UL SP) 50%     | 25%                 | 37.5%          | 50%                 |
| DCVSP (DCV UL SP)<br>100% | 50%                 | 50%            | 50%                 |

### Operation for RTRM 8.0 and Later with RTEM

Once configured appropriately as described above, the potentiometers Design Min Pos and DCV Min Pos must each be set in order to control the OA damper position. The Design Min Pos potentiometer determines the OA damper position (from 0 to 50%) when the IGV/VFD is at 100%. The DCV Min Pos potentiometer determines the OA damper position (from 0 to 50%) when the IGV/VFD is at 0%.

**Note:** This function is disabled if a building management system (ICS, Tracer®, LonTalk®) is providing an OA damper minimum position setpoint to the unit. This function is disabled if the unit is using a CO<sub>2</sub> sensor input at the DCV input or if a building management system (ICS, Tracer®, LonTalk®) is providing a CO<sub>2</sub> sensor input to the unit.

The active economizer minimum position will be computed as a linear function, based on reported inlet vane or VFD position, given the two endpoints:

- Minimum position with IGV @ 100%

- Minimum position with IGV @ 0%

**Figure 129. OA damper minimum position with IGV/VFD at 0% and 100%**

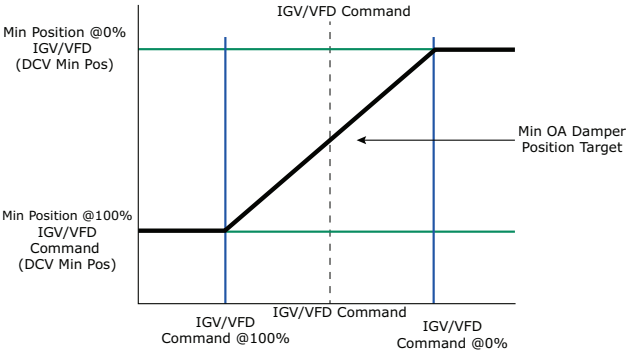





Trane and American Standard create comfortable, energy efficient indoor environments for commercial and residential applications. For more information, please visit [trane.com](http://trane.com) or [americanstandardair.com](http://americanstandardair.com).

Trane and American Standard have a policy of continuous product and product data improvement and reserve the right to change design and specifications without notice. We are committed to using environmentally conscious print practices.

RT-SVD03N-EN 01 Aug 2022  
Supersedes RT-SVD03M-EN (May 2020)

©2022