

# Installation

## Variable Refrigerant Flow System Outdoor Unit Series

### Models:

#### (HP,208-230 V)

4TVH0072\*300N\*  
4TVH0096\*300N\*  
4TVH0120\*300N\*  
4TVH0144\*300N\*  
4TVH0168\*300N\*  
4TVH0192\*300N\*  
4TVHL072\*300N\*  
4TVHL096\*300N\*

#### (HP,460 V)

4TVH0072\*400N\*  
4TVH0096\*400N\*  
4TVH0120\*400N\*  
4TVH0144\*400N\*  
4TVH0168\*400N\*  
4TVH0192\*400N\*  
4TVHL072\*400N\*  
4TVHL096\*400N\*

#### (HR,208-230 V)

4TVR0072\*300N\*  
4TVR0096\*300N\*  
4TVR0120\*300N\*  
4TVR0144\*300N\*  
4TVR0168\*300N\*  
4TVR0192\*300N\*  
4TVRL072\*300N\*  
4TVRL096\*300N\*

#### (HR,460 V)

4TVR0072\*400N\*  
4TVR0096\*400N\*  
4TVR0120\*400N\*  
4TVR0144\*400N\*  
4TVR0168\*400N\*  
4TVR0192\*400N\*  
4TVRL072\*400N\*  
4TVRL096\*400N\*

### SAFETY WARNING

Only qualified personnel should install and service the equipment. The installation, starting up, and servicing of heating, ventilating, and air-conditioning equipment can be hazardous and requires specific knowledge and training. Improperly installed, adjusted or altered equipment by an unqualified person could result in death or serious injury. When working on the equipment, observe all precautions in the literature and on the tags, stickers, and labels that are attached to the equipment.



# Introduction

## Warnings, Cautions, and Notices

Safety advisories appear throughout this manual as required. Your personal safety and the proper operation of this machine depend upon the strict observance of these precautions.

---

The three types of advisories are defined as follows:

 <b>WARNING</b>	Indicates a potentially hazardous situation which, if not avoided, could result in death or serious injury.
 <b>CAUTION</b>	Indicates a potentially hazardous situation which, if not avoided, could result in minor or moderate injury. It could also be used to alert against unsafe practices.
<b>NOTICE</b>	Indicates a situation that could result in equipment or property-damage only accidents.

---

## Important Environmental Concerns

Scientific research has shown that certain man-made chemicals can affect the earth's naturally occurring stratospheric ozone layer when released to the atmosphere. In particular, several of the identified chemicals that may affect the ozone layer are refrigerants that contain Chlorine, Fluorine and Carbon (CFCs) and those containing Hydrogen, Chlorine, Fluorine and Carbon (HCFCs). Not all refrigerants containing these compounds have the same potential impact to the environment. Trane advocates the responsible handling of all refrigerants—including industry replacements for CFCs and HCFCs such as saturated and unsaturated HFCs and HCFCs.

## Important Responsible Refrigerant Practices

Trane believes that responsible refrigerant practices are important to the environment, our customers, and the air conditioning industry. All technicians who handle refrigerants must be certified. The Federal Clean Air Act (Section 608) sets forth the requirements for handling, reclaiming, recovering and recycling of certain refrigerants and the equipment that is used in these service procedures. In addition, some states or municipalities may have additional requirements that must also be adhered to for responsible management of refrigerants. Know the applicable laws and follow them.

### **WARNING**

#### **Proper Field Wiring and Grounding Required!**

**Failure to follow code could result in death or serious injury. All field wiring MUST be performed by qualified personnel. Improperly installed and grounded field wiring poses FIRE and ELECTROCUTION hazards. To avoid these hazards, you MUST follow requirements for field wiring installation and grounding as described in NEC and your local/state electrical codes. Failure to follow code could result in death or serious injury.**

**⚠ WARNING**

**Personal Protective Equipment (PPE) Required!**

Failure to wear proper PPE for the job being undertaken could result in death or serious injury. Technicians, in order to protect themselves from potential electrical, mechanical, and chemical hazards, **MUST** follow precautions in this manual and on the tags, stickers, and labels, as well as the instructions below:

- Before installing/servicing this unit, technicians **MUST** put on all PPE required for the work being undertaken (Examples; cut resistant gloves/sleeves, butyl gloves, safety glasses, hard hat/bump cap, fall protection, electrical PPE and arc flash clothing). **ALWAYS** refer to appropriate Material Safety Data Sheets (MSDS)/Safety Data Sheets (SDS) and OSHA guidelines for proper PPE.
- When working with or around hazardous chemicals, **ALWAYS** refer to the appropriate MSDS/ SDS and OSHA/GHS (Global Harmonized System of Classification and Labelling of Chemicals) guidelines for information on allowable personal exposure levels, proper respiratory protection and handling instructions.
- If there is a risk of energized electrical contact, arc, or flash, technicians **MUST** put on all PPE in accordance with OSHA, NFPA 70E, or other country-specific requirements for arc flash protection, **PRIOR** to servicing the unit. **NEVER PERFORM ANY SWITCHING, DISCONNECTING, OR VOLTAGE TESTING WITHOUT PROPER ELECTRICAL PPE AND ARC FLASH CLOTHING. ENSURE ELECTRICAL METERS AND EQUIPMENT ARE PROPERLY RATED FOR INTENDED VOLTAGE.**

## Copyright

This document and the information in it are the property of Trane, and may not be used or reproduced in whole or in part without written permission. Trane reserves the right to revise this publication at any time, and to make changes to its content without obligation to notify any person of such revision or change.

## Trademarks

All trademarks referenced in this document are the trademarks of their respective owners.

## Revision History

Version D contains new unit models 4TVHL072/096 and 4TVRL072/096, control board changes, and a procedure for automatic addressing of new MCUs.

# Table of Contents

Model Number Description .....	6
Preparing for Installation .....	7
Unit Dimensions and Weights .....	7
Minimum Operating Clearances .....	11
Outdoor Unit Combinations .....	12
Unit Corner Weights and Centers of Gravity .....	14
Accessories .....	15
Moving the Outdoor Unit .....	17
Location Considerations .....	17
Unit Installation .....	19
Base Recommendations .....	19
Water Management .....	20
Securing the Outdoor Unit .....	21
Condenser Discharge Air Duct (optional) .....	22
Wind Baffle/Discharge Air Hood (optional) .....	23
Refrigerant Piping .....	24
Selecting Refrigerant Piping .....	24
Heat Pump Applications .....	24
Heat Recovery Applications .....	27
Pipe Thickness and Temper Grade .....	30
Storing Refrigerant Piping .....	31
Installing Refrigerant Piping .....	31
Overview .....	32
Pipe Cutting .....	32
Nitrogen Flushing While Brazing .....	32
Flared Pipe Connections .....	33
Connecting Piping to the Outdoor Unit .....	34
Connecting Outdoor Units with Y-joints .....	35
Refrigerant Piping Installation Examples: Heat Pump .....	37
Refrigerant Piping Installation Examples: Heat Recovery .....	41
Electrical Wiring .....	45
Power Wiring .....	47
Grounding .....	51
Communications Wiring .....	52
Leak Testing Pipe Connections .....	54
Vacuum Drying .....	57
Insulating Refrigerant Pipes .....	58

---

Refrigerant .....	60
Calculating the Refrigerant .....	60
Charging Refrigerant .....	63
Control System .....	65
Monitoring System Power and Communication Status .....	65
System Configuration .....	66
Initiating System Operations .....	70
Monitoring System Settings and Software Versions .....	71
Automatic Port Addressing Operation .....	73
Requirements Prior to Performing the Operation .....	73
Performing the Operation .....	74
Pre-Start Checks .....	75
Test Operation .....	77
Refrigerant Amount Detection Operation .....	79
Error Codes .....	80

# Model Number Description

4	T	V	R	0	0	9	6	B	3	0	0	N	A
1	2	3	4	5	6	7	8	9	10	11	12	13	14

## Digit 1: Refrigerant

4 = R-410A

## Digit 2: Brand name

T = Trane

## Digit 3: System type

V = Variable Refrigerant Flow

## Digit 4: Functional Type Outdoor Unit

H = Heat Pump, DC Inverter (VRF)

R = Heat Recovery (3-pipe), DC Inverter (VRF)

## Digit 5: Efficiency Tier and/or Special Application

0 = Standard

L = Low Ambient Heat

## Digit 6, 7, 8: Nominal capacity (Btu/h x 1,000)

072 = 72,000 Btu/h (VRF)

096 = 96,000 Btu/h (VRF)

120 = 120,000 Btu/h (VRF)

144 = 144,000 Btu/h (VRF)

168 = 168,000 Btu/h (VRF)

192 = 192,000 Btu/h (VRF)

## Digit 9: Major development sequence

A = First development sequence

B = Second development sequence

C = Third development sequence

## Digit 10: Electric power supply characteristics

3 = 208-230/60/3

4 = 460/60/3

## Digit 11: Coil fin protection

0 = Standard

## Digit 12: Miscellaneous digit

0 = Not currently used

## Digit 13: Region of sale

N = North America (VRF)

## Digit 14: Minor design sequence

A = First design sequence

B = Second design sequence

C = Third design sequence

D = Fourth design sequence

# Preparing for Installation

## Unit Dimensions and Weights

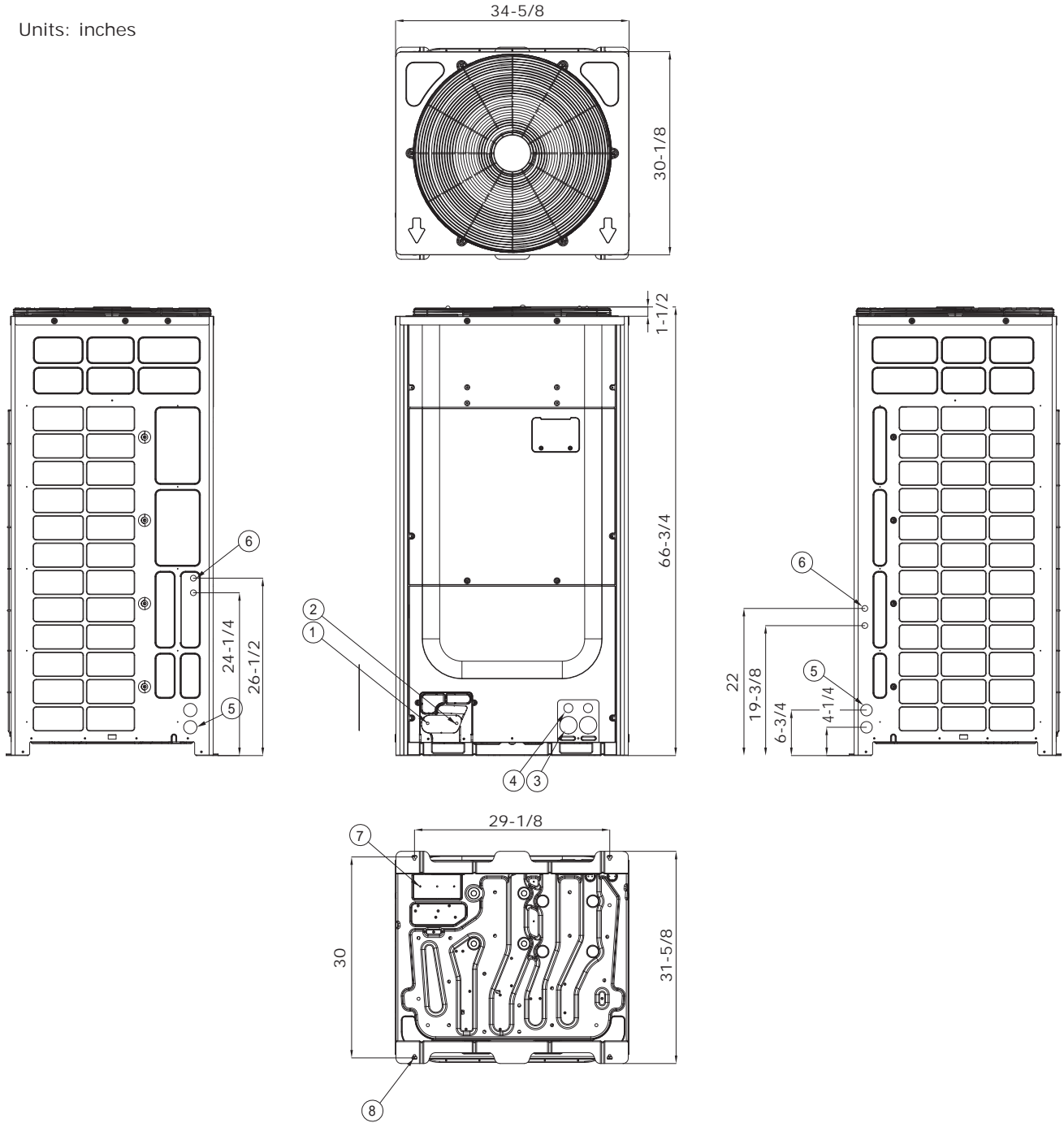
**Table 1. Unit dimensions and weights**

Unit type	Unit model number	Dimensions (WxHxD) (in.)	Weight (lb)	Shipping dimensions (WxHxD) (in.)	Shipping weight (lb)
Heat Pump (203–230 V)	4TVH0072C300NA	34-5/8 x 66-3/4 x 30-1/8	416.2	37-1/4 x 74-1/4 x 32-7/8	451.5
	4TVH0096C300NA	51 x 66-3/4 x 30-1/8	621.9	53-3/4 x 74-1/4 x 32-7/8	663.8
	4TVH0120C300NA		655		696.9
	4TVH0144C300NA		710.5		748
	4TVH0168C300NA		728.6		766.1
	4TVH0192C300NA		651.7		693.6
	4TVHL072B300NA		734.4		771.8
	4TVHL096B300NA				
Heat Recovery (203–230 V)	4TVR0072C300NA		34-5/8 x 66-3/4 x 30-1/8		420.6
	4TVR0096C300NA	51 x 66-3/4 x 30-1/8	635.2	53-3/4 x 74-1/4 x 32-7/8	677
	4TVR0120C300NA		670.4		712.3
	4TVR0144C300NA		726		763.5
	4TVR0168C300NA		744.1		781.5
	4TVR0192C300NA		666.5		708.3
	4TVRL072B300NA		744.1		781.5
	4TVRL096B300NA				
Heat Pump (460 V)	4TVH0072C400NA		34-5/8 x 66-3/4 x 30-1/8		427.3
	4TVH0096C400NA	51 x 66-3/4 x 30-1/8	538.1	53-3/4 x 74-1/4 x 32-7/8	580
	4TVH0120C400NA		670.4		712.3
	4TVH0144C400NA		713		750.5
	4TVH0168C400NA		730.6		768.1
	4TVH0192C400NA		667.1		709
	4TVHL072B400NA		736.3		773.8
	4TVHL096B400NA				
Heat Recovery (460 V)	4TVR0072C400NA		34-5/8 x 66-3/4 x 30-1/8		436.1
	4TVR0096C400NA	51 x 66-3/4 x 30-1/8	551.4	53-3/4 x 74-1/4 x 32-7/8	593.3
	4TVR0120C400NA		690.3		732.2
	4TVR0144C400NA		728.6		766.1
	4TVR0168C400NA		746		783.5
	4TVR0192C400NA		686.3		728.2
	4TVRL072B400NA		746		783.5
	4TVRL096B400NA				

# Preparing for Installation

Figure 1. Dimensional drawing: 4TVH0072\*\*\*\*/4TVR0072\*\*\*\*

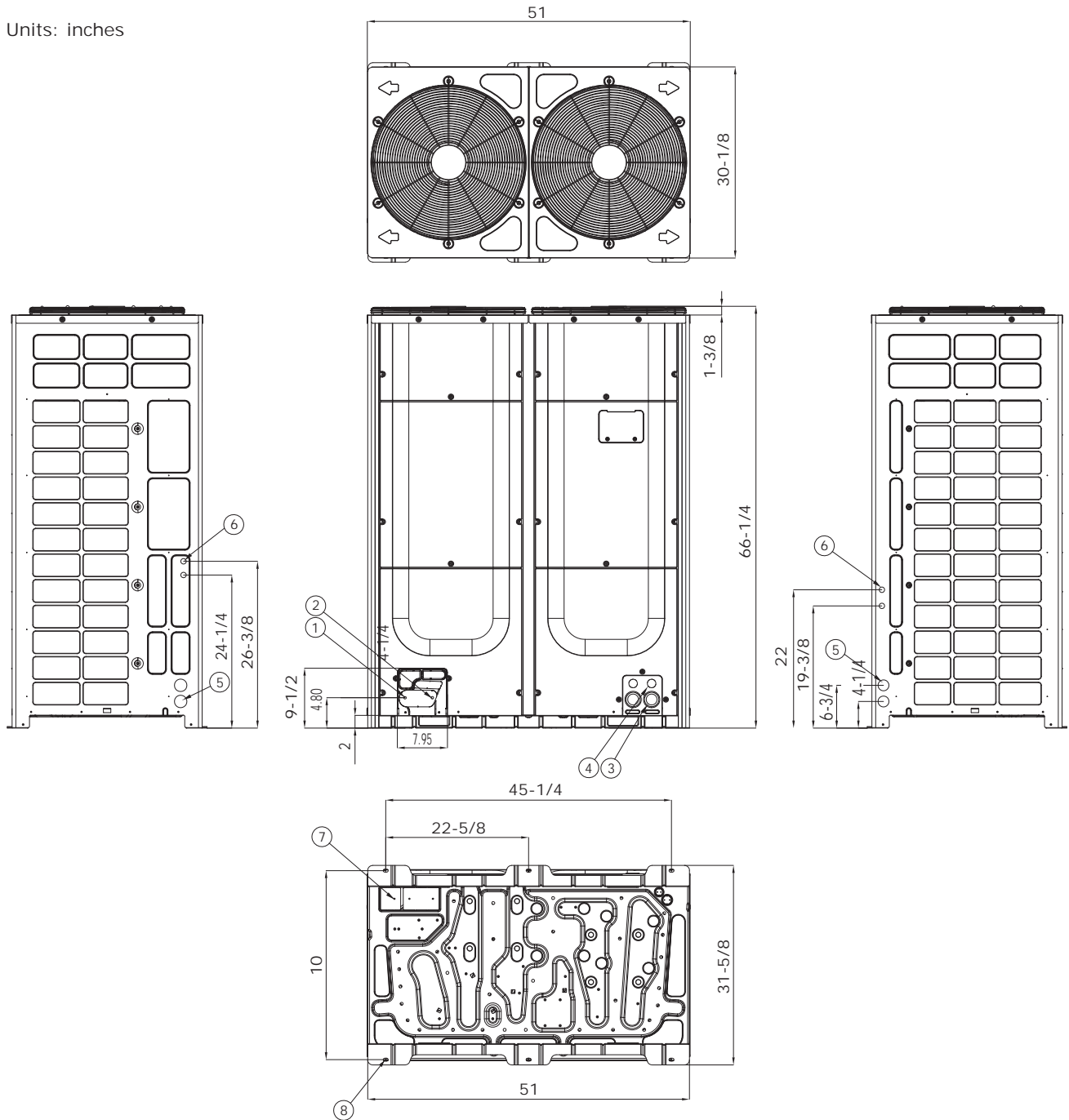
Units: inches





**Figure 2. Dimensional drawing:**  
**4TVH0096/120/144/168/192\*\*\*\*/4TVR0096/120/144/168/192\*\*\*\***

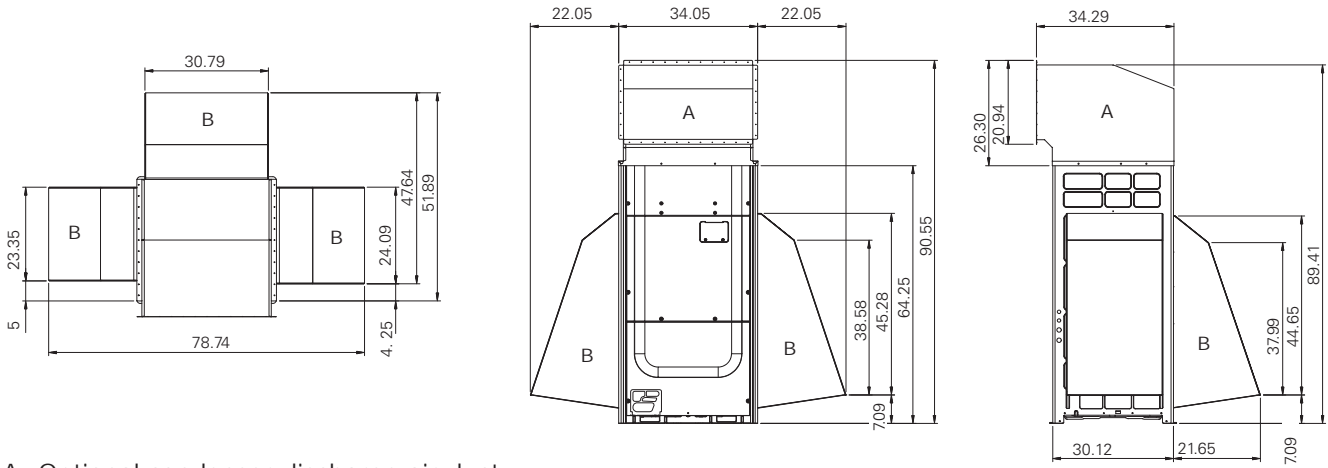
Units: inches



## Preparing for Installation

**Figure 3. Dimensional drawing of units with optional duct/baffles:  
4TVH0072\*\*\*\*/4TVR0072\*\*\*\***

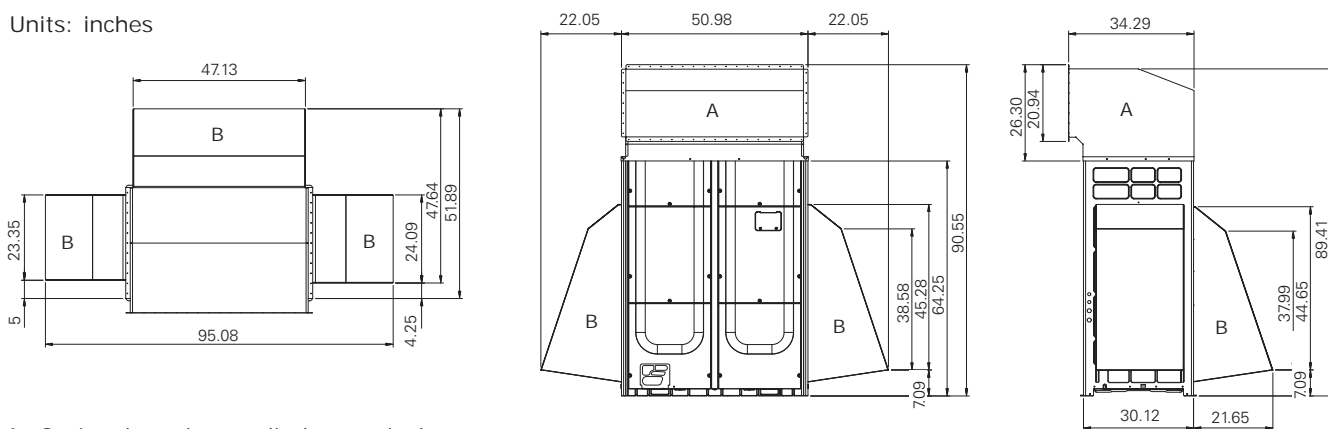
Units: inches



A: Optional condenser discharge air duct  
B: Optional wind baffle/discharge air hood

**Figure 4. Dimensional drawing of units with optional duct/baffles:  
4TVH0096/120/144/168/192\*\*\*\*/4TVR0096/120/144/168/192\*\*\*\***

Units: inches

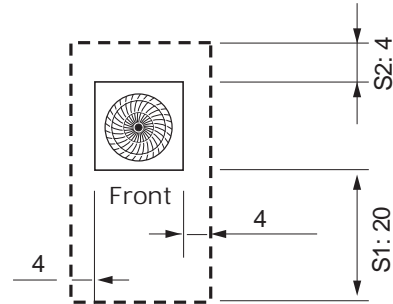


A: Optional condenser discharge air duct  
B: Optional wind baffle/discharge air hood

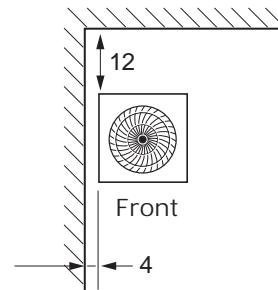
## Minimum Operating Clearances

Install units as shown in the illustrations below, observing ventilation and service requirements. Space requirements are based on cooling mode operation and an outdoor temperature of 95°F (35°C). More space is required if the outdoor temperature is higher than 95°F (35°C) or if the area is easily heated by solar radiation.

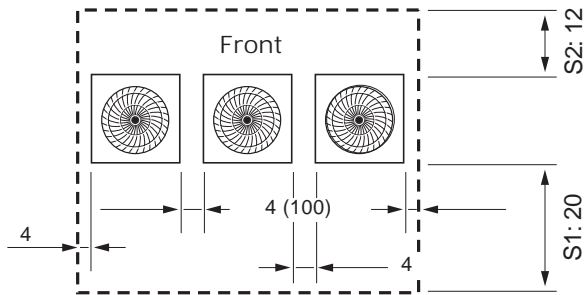
**Figure 5. Minimum operating clearances for single and multiple units**



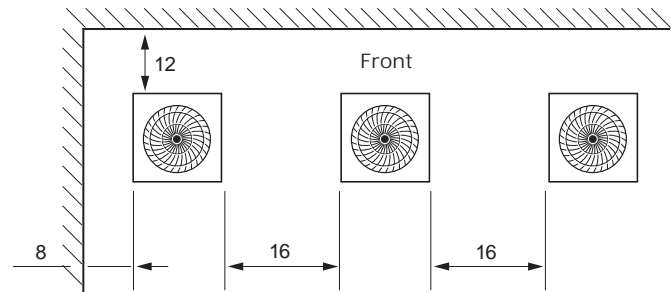
**Example 1: Single unit inside pit**



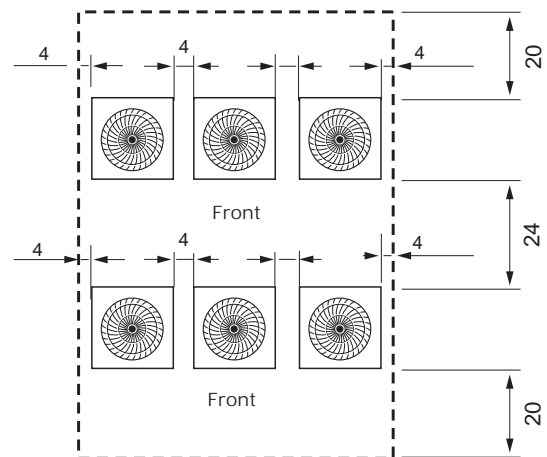
**Example 2: Single unit inside wall**



**Example 3: Multiple units inside pit**



**Example 4: Multiple units inside wall**



**Example 5: Multiple units inside pit**

**Notes:**

Units: inches

Clearances in this manual are minimum for system operation. all installations shall comply with codes and standards adopted by the Authority Having Jurisdiction (AHJ).

S1 = Front service clearance

S2 = Back service clearance

See Figure 6, p. 12 for details.

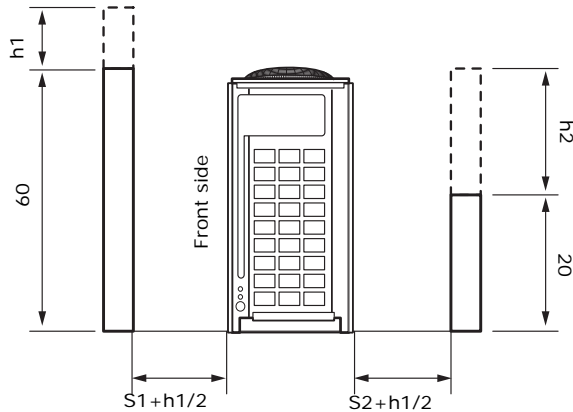
You may install multiple outdoor units with a minimum 1 in. (20 mm) of space between them, but reduced capacity may occur depending on the installation environment.

Clearance requirements are waived for any unit sides that have wind/snow protection ducts installed on them, due to the wind/snow protection duct size, which exceeds clearance requirements.

## Preparing for Installation

**Figure 6. Dimension limits for pit**

**Note:** This figure refers to Figure 3, examples 1, 3, 5.



Front wall height recommendation: 60 in. maximum.  
Back wall height recommendation: 20 in. maximum.  
Side wall height is unlimited.

If a wall exceeds the recommended height, an additional clearance of half of the exceeded height should be added to the service clearance. (Clearances are given in [Figure 5, p. 11](#)).

$S1$  = Front service clearance  
 $S2$  = Back service clearance  
 $h1$  = Wall height in excess of 60 in.  
 $h2$  = Wall height in excess of 20 in.

## Outdoor Unit Combinations

Use the following table to determine the size and number of outdoor units needed to achieve the capacity requirements.

Follow these guidelines:

- Make sure to use indoor units that are compatible with the outdoor unit.
- The minimum capacity of an indoor unit is 5 MBH (5000 Btu/h).
- Indoor units can be connected within the ranges indicated in [Table 2](#) and [Table 3](#).
- If the total capacity of the connected indoor units exceeds the indicated maximum capacity, the cooling and heating capacity of the indoor unit may decrease.
- You can connect a maximum of 64 indoor units to the outdoor unit. The maximum quantity of connectable indoor units is 64 because the outdoor unit supports a maximum of 64 communication addresses.
- If you choose to select outdoor unit combination other than the ones in [Table 2](#) or [Table 3](#), the total capacity of connected indoor units is allowed to be 50%–130% of the outdoor unit capacity:  $[0.5 \times \text{total outdoor unit capacity} \leq \text{total connected indoor unit capacity} \leq 1.3 \times \text{total outdoor unit capacity}]$ .

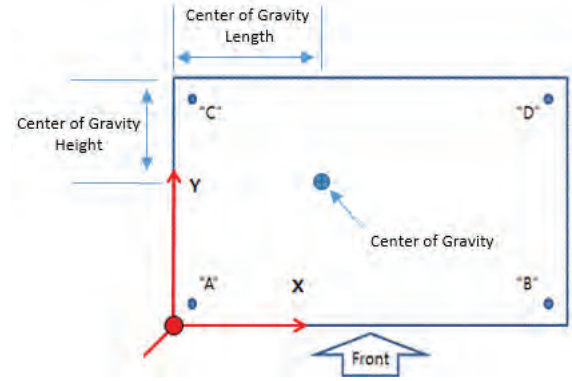
**Table 2. Outdoor unit combinations: 6–24 ton capacity**

Capacity		6 ton	8 ton	10 ton	12 ton	14 ton	16 ton	18 ton	20 ton	22 ton	24 ton
Outdoor unit combination number		4TV*0072	4TV*0096	4TV*0120	4TV*0144	4TV*0168	4TV*0192	4TV*0216	4TV*0240	4TV*0264	4TV*0288
Total number of individual outdoor units		1	1	1	1	1	1	2	2	2	2
Combined outdoor unit	4TV*0072	1						1	1	1	
	4TV*0096		1								
	4TV*0120			1							
	4TV*0144				1			1			2
	4TV*0168					1			1		
	4TV*0192						1			1	
Nominal Capacity	Cooling (Btu/h)	72000	96000	120000	144000	168000	192000	216000	240000	264000	288000
	Heating (Btu/h)	81000	108000	135000	162000	189000	216000	243000	270000	297000	324000
Rated Capacity	Cooling (Btu/h)	69000	92000	114000	138000	160000	184000	206000	228000	252000	276000
	Heating (Btu/h)	77000	103000	129000	154000	180000	206000	230000	258000	282000	308000
Total capacity of connected indoor units (cooling)	Minimum (Btu/h)	36000	48000	60000	72000	84000	96000	108000	120000	132000	144000
	Maximum (Btu/h)	93600	124800	156000	187200	218400	249600	280800	312000	343200	374400
Maximum quantity of connectable indoor units		12	16	20	25	29	33	37	41	45	49

**Table 3. Outdoor unit combinations: 26–44 ton capacity**

Capacity		26 ton	28 ton	30 ton	32 ton	34 ton	36 ton	38 ton	40 ton	42 ton	44 ton
Model name for Combination		4TV*0312	4TV*0336	4TV*0360	4TV*0384	4TV*0408	4TV*0432	4TV*0456	4TV*0480	4TV*0504	4TV*0528
Total number of individual outdoor units		2	2	2	2	3	3	3	3	3	3
Combined outdoor unit	4TV*0072					1					
	4TV*0096										
	4TV*0120							1			
	4TV*0144	1				1	3		1		
	4TV*0168	1	2	1				2	2	3	2
	4TV*0192			1	2	1					
Nominal capacity	Cooling (Btu/h)	312000	336000	360000	384000	408000	432000	456000	480000	504000	528000
	Heating (Btu/h)	351000	378000	405000	432000	459000	486000	513000	540000	567000	594000
Rated capacity	Cooling (Btu/h)	298000	320000	344000	366000	390000	415000	435000	455000	480000	500000
	Heating (Btu/h)	334000	360000	386000	410000	435000	460000	490000	510000	535000	560000
Total capacity of indoor units (cooling)	Minimum (Btu/h)	156000	168000	180000	192000	204000	216000	228000	240000	252000	264000
	Maximum (Btu/h)	405600	436800	468000	499200	530400	561600	592800	624000	655200	686400
Maximum quantity of connectable indoor units		54	58	62	64	64	64	64	64	64	64

## Unit Corner Weights and Centers of Gravity



**Table 4. Unit corner weights and centers of gravity**

Model	Net weight (lbs)	Corner weights (lbs)				Center of gravity	
		A	B	C	D	Length (in.)	Width (in.)
4TVH0072C300NA	416.2	87	111	106	116	18	16
4TVH0096C300NA	621.9	140	159	157	168	26	16
4TVH0120C300NA	621.9	140	159	157	168	26	16
4TVH0144C300NA	655	148	168	166	179	26	16
4TVH0168C300NA	710.5	197	171	197	151	26	15
4TVH0192C300NA	728.6	202	175	202	155	26	15
4TVR0072C300NA	420.6	92	111	106	121	17	16
4TVR0096C300NA	635.2	146	159	156	175	25	16
4TVR0120C300NA	635.2	146	159	156	175	25	16
4TVR0144C300NA	670.4	155	168	166	185	25	16
4TVR0168C300NA	726	201	175	201	155	26	15
4TVR0192C300NA	744.1	206	179	206	158	26	15
4TVH0072C400NA	427.3	90	116	110	121	18	16
4TVH0096C400NA	538.1	135	125	123	156	23	16
4TVH0120C400NA	538.1	135	125	123	156	23	16
4TVH0144C400NA	670.4	151	171	168	182	26	16
4TVH0168C400NA	713	198	172	198	152	26	15
4TVH0192C400NA	730.6	202	176	202	156	26	15
4TVR0072C400NA	436.1	95	115	109	125	17	16
4TVR0096C400NA	551.4	127	138	136	152	25	16
4TVR0120C400NA	551.4	127	138	136	152	25	16
4TVR0144C400NA	690.3	159	173	170	190	25	16
4TVR0168C400NA	728.6	202	176	202	155	26	15
4TVR0192C400NA	746	207	180	207	159	26	15
4TVHL072B300NA	651.7	148	168	166	179	26	16
4TVHL096B300NA	734.4	202	175	202	155	26	15

**Table 4. Unit corner weights and centers of gravity (continued)**

Model	Net weight (lbs)	Corner weights (lbs)				Center of gravity	
		A	B	C	D	Length (in.)	Width (in.)
4TVRL072B300NA	666.5	155	168	166	185	25	16
4TVRL096B300NA	744.1	206	179	206	158	26	15
4TVHL072B400NA	667.1	151	171	168	182	26	16
4TVHL096B400NA	736.3	202	176	202	156	26	15
4TVRL072B400NA	686.3	159	173	170	190	25	16
4TVRL096B400NA	746	207	180	207	159	26	15

## Accessories

Accessories that ship with the unit are:

- Instruction manual
- Brand label and instruction sheet
- Pipe installation sockets (see [Table 5](#) and [Figure 7](#)).

**Table 5. Pipe installation socket size chart**

Model number	Connection type	Heat recovery				Heat pump		
		Gas	Liquid	High-pressure gas	Socket needed	Gas	Liquid	Socket needed
4TV*0072***** (6 ton)	Unit connection	3/4 in.	3/8 in.	5/8 in.	No	3/4 in.	3/8 in.	No
	Field connection							
4TV*0096***** (8 ton) <sup>(a)</sup>	Unit connection	1-1/8 in.	1/2 in.	7/8 in.	Yes	1 in.	1/2 in.	Yes
	Field connection	7/8 in.	3/8 in.	3/4 in.		7/8 in.	3/8 in.	
4TV*0120***** (10 ton) <sup>(a)</sup>	Unit connection	1-1/8 in.	1/2 in.	7/8 in.	Yes	1 in.	1/2 in.	Yes
	Field connection			3/4 in.		1-1/8 in.		
4TV*0144***** (12 ton) <sup>(a)</sup>	Unit connection	1-1/8 in.	5/8 in.	1-1/8 in.	Yes	1-1/8 in.	1/2 in.	No
	Field connection		1/2 in.	7/8 in.				
4TV*0168***** (14 ton) <sup>(a)</sup>	Unit connection	1-1/8 in.	5/8 in.	1-1/8 in.	Yes	1-1/8 in.	5/8 in.	No
	Field connection			7/8 in.				
4TV*0192***** (16 ton)	Unit connection	1-1/8 in.	5/8 in.	1-1/8 in.	No	1-1/8 in.	5/8 in.	No
	Field connection							
4TV*L072***** (6 ton)	Unit connection	1-1/8 in.	5/8 in.	1-1/8 in.	Yes	1-1/8 in.	1/2 in.	Yes
	Field connection	3/4 in.	3/8 in.	5/8 in.		3/4 in.	3/8 in.	
4TV*L096***** (8 ton)	Unit connection	1-1/8 in.	5/8 in.	1-1/8 in.	Yes	1-1/8 in.	5/8 in.	Yes
	Field connection	7/8 in.	3/8 in.	3/4 in.		7/8 in.	3/8 in.	

(a) Cut socket as needed for 8, 10, 12, and 14 ton units.

**Figure 7. Pipe installation sockets**

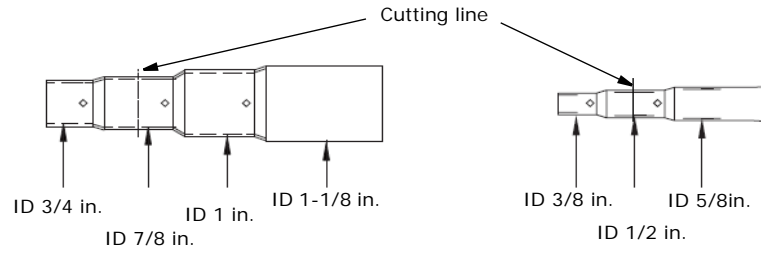


Table 6 shows piping connectors for outdoor units.

**Table 6. Piping connectors**

Accessory	Model number	Specification
Indoor Y-joint	4YDK1509B0051A	51 MBH and below
	4YDK2512B0138A	52–136 MBH
	4YDK2812B0160A	137–154 MBH
	4YDK2815B0240A	155–240 MBH
	4YDK3419B0336A	241–336 MBH
	4YDK4119B0468A	337–461 MBH
	4YDK4422B0999A	Above 461 MBH
Indoor Y-joint for heat recovery (high-pressure gas)	4YDK1500B0080A	76 MBH and below
	4YDK2500B0240A	77–240 MBH
	4YDK3100B0468A	241–461 MBH
	4YDK3800B0999A	Above 461 MBH
Distribution header	4HJK2512B0159A	154 MBH and below (maximum number of connections: 4)
	4HJK3115B0241A	240 MBH and below (maximum number of connections: 8)
	4HJK3819B0998A	Above 240 MBH (maximum number of connections: 8)
Outdoor Y-joint	4TDK3819B0000A	456 MBH and below
	4TDK4422B0999A	Above 456 MBH
Outdoor Y-joint for heat recovery (high-pressure gas)	4TDK3100B0000A	456 MBH and below
	4TDK3800B0999A	Above 456 MBH
Electronic expansion valve (EEV) kit <sup>(a)</sup>	4EEVEVA32SA000	≥ 17 MBH (for 1 indoor unit)

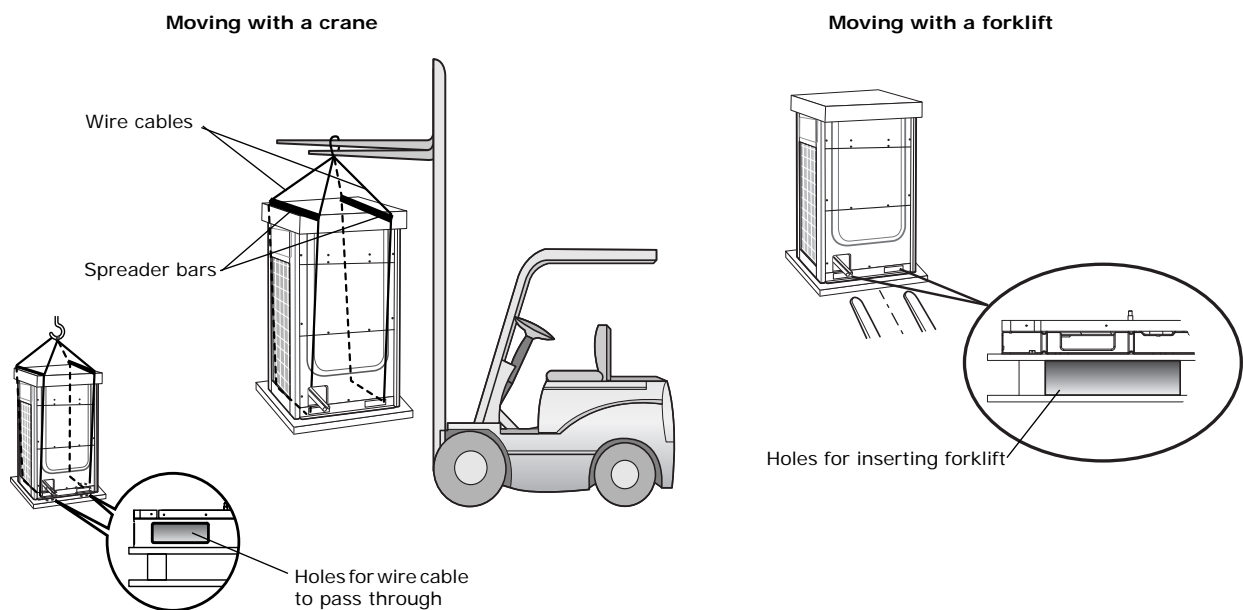
(a) Required for indoor units that do not have internal EEVs. Refer to the EEV kit installation guide (VRF-SVN43) for detailed information.



## Moving the Outdoor Unit

Follow these guidelines when moving the outdoor unit:

- Before moving the outdoor unit, determine a path that can support its weight.
- Do not lay the unit on its side and do not tip it more than 30 degrees.
- Take care to avoid injury while moving the unit; the surface of the heat exchanger is sharp.
  - If moving the unit with a crane, fasten the wire rope as shown in the figure below. To protect damage or scratches to the unit, use a spreader bar.
  - If moving the unit with a forklift, carefully insert forks into the forklift holes at the bottom of the outdoor unit. Be careful with to avoid damaging the unit with the forklift.



## Location Considerations

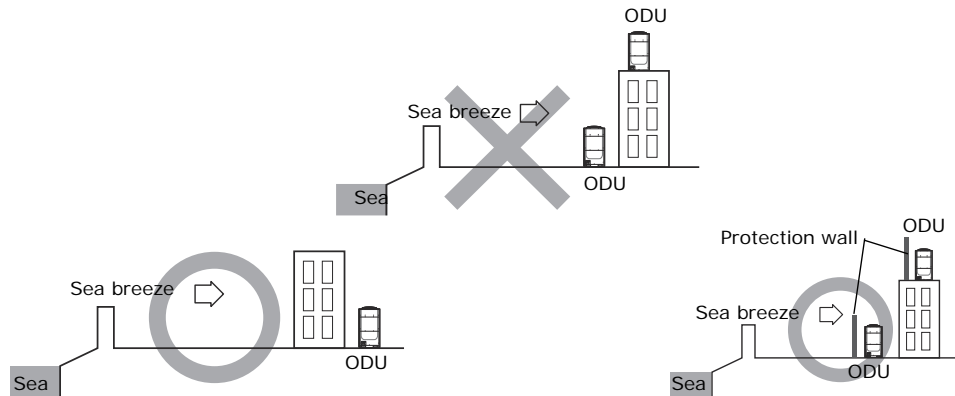
Choose an installation location based on the following considerations.

- Install the outdoor unit:
  - On a supporting structure that can bear the weight of the outdoor unit. The supporting structure can be a base on the ground, on a waterproof roof, or in a pit.
  - With sufficient clearances around the unit for service and repairs.
  - On a flat surface that does not collect water
  - In a well ventilated location.
  - Away from strong wind.
  - Away from direct exposure to snow.
  - Where there is no risk of flammable gas leakage.
  - Where there is no exposure to salt, machine oil, sulfide gas, or corrosive environmental conditions.
  - Away from sea breeze.

## Preparing for Installation

---

**Note:** For seacoast applications, block the unit from direct exposure to sea breeze by installing the outdoor unit (ODU) behind a structure (such as a building) or a protective wall that is 1.5 times higher than the unit, leaving 28 in. (700 mm) of space between the wall and unit for air circulation. Consult an installation expert about taking anti-corrosion measures, such as removing salinity on the heat exchanger and applying a rust inhibitor more frequently than once a year.



- At least 9.84 ft away from equipment that generates electromagnetic waves.
- Away from interfering sources, such as radio, computer, and stereo equipment.
- Far enough away from people living and working nearby so that hot discharge air or noise do not disturb them.
- Away from inflammable materials.
- Ensure that condensate water generated by the outdoor unit can drain smoothly away from the unit.
- Install the power and communication cables in a separately installed enclosure.
- If installing on a high place such as a roof, a fence or guard rail should be installed around the unit to safeguard it from falling.
- If there is a potential for accumulated snow to block the air inlet or heat exchanger, install the unit on a base higher than the highest possible snow accumulation.
- R-410A refrigerant is a safe, nontoxic and nonflammable refrigerant. However, if there is a concern about a dangerous level of refrigerant concentration in the case of refrigerant leakage, add extra ventilation.
- Avoid installing the outdoor unit where corrosive gases, such as sulfur oxides, ammonia, and sulfurous gas, are produced. If unavoidable, consult with an installation specialist about using a corrosion-proof or anti-rust additive to protect the unit coils.
- Apply corrosion protection and any other protective coatings to the unit as appropriate to the environment.

# Unit Installation

Follow these guidelines for installing the outdoor unit.

**Important:** *The manufacturer is not responsible for damage incurred for installations that have not followed these guidelines.*

The outdoor unit must be installed:

- On a horizontally level surface.
- On a surface that is strong enough to support the unit and to minimize noise.

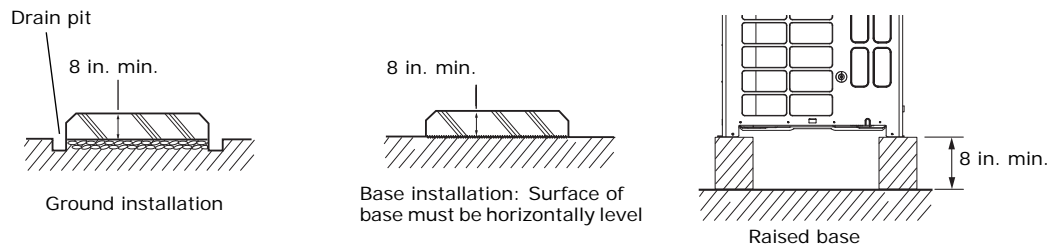
## Base Recommendations

### General Guidelines

A supporting base for the outdoor unit:

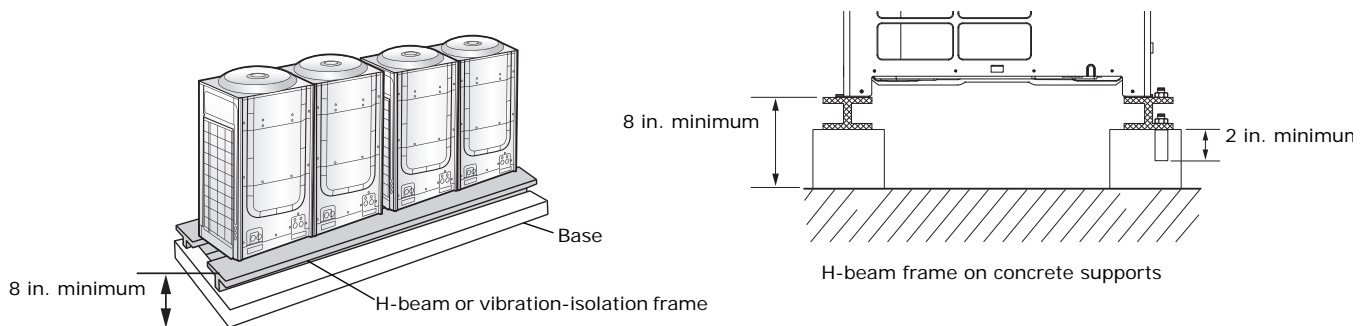
- Is typically made of concrete.
- If necessary, has wire mesh or steel bars added to the concrete to prevent damages or cracks.
- Should typically be 1.5 times larger than the bottom of the outdoor unit. However, for installations that are subject to snow accumulation, the base should be no larger than the bottom of the unit.
- Should be 8 in. or higher to protect the outdoor unit from rain water or other conditions that may cause damage to the unit.

**Note:** *The base height or, if the unit is installed on a frame (see “Minimizing Vibration” p. 19), the base height plus the frame height, should be greater than the highest expected snowfall.*



### Minimizing Vibration

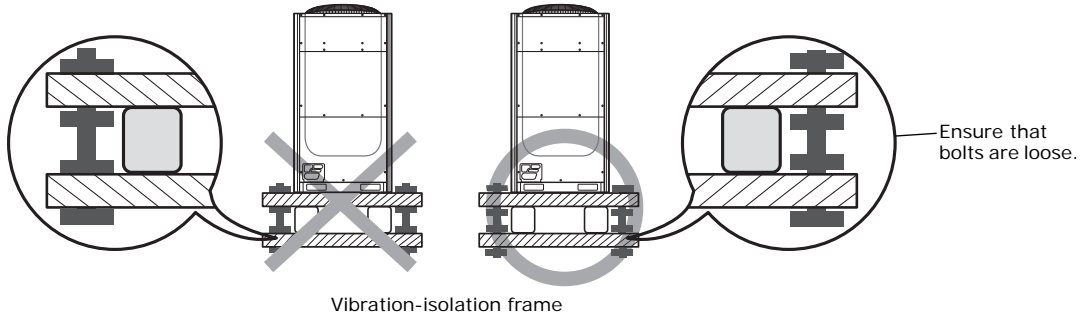
To minimize outdoor unit vibrations, use a vibration-minimizing structure such as an H-beam frame, a vibration-isolation frame, or an isolation pad (thickness > 1 in.). The load-bearing force of the structure must be 787 lbf.



After installing a vibration-isolation frame:

## Unit Installation

- Loosen the bolts so that the isolators are capable of absorbing vibrations (refer to the figure below).



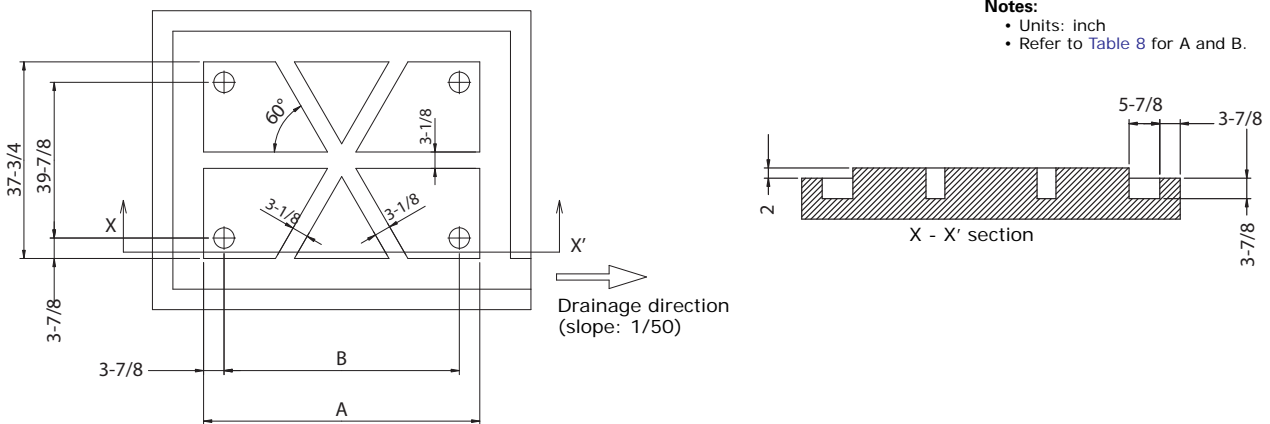
- Apply corrosion-resistant protection to the frame.

## Water Management

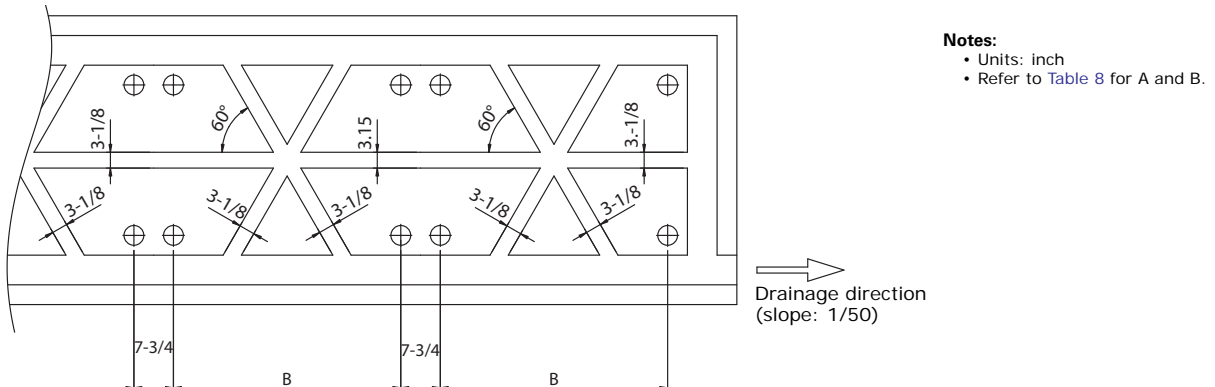
If the outdoor unit base is at ground level, construct a drainage pit around it to prevent the drain water from collecting near the unit.

- Use wire mesh or steel bar for constructing the drainage pit.
- Construct the pit with a slope of 1:50.

**Figure 8. Water management for single-unit installation**



**Figure 9. Water management for multiple-unit installation**



## Securing the Outdoor Unit

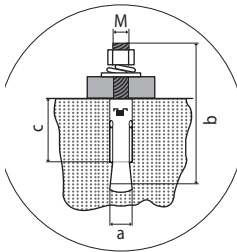
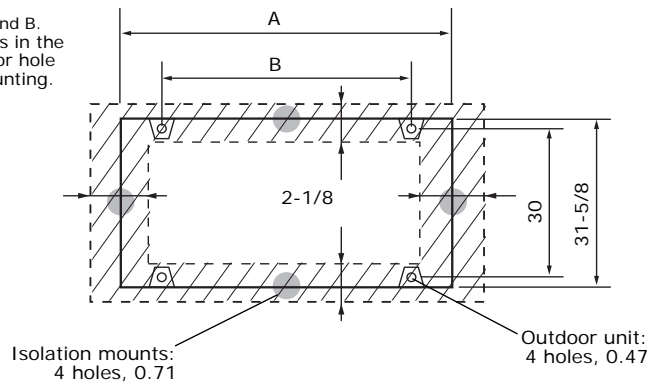
Secure the outdoor unit firmly to the base with anchor bolts, as specified in [Figure 10](#), [Table 7](#), and [Table 8](#)).

- Use zinc-plated or stainless steel nuts and bolts.
- Use a rubber washer between the bolt and the outdoor unit to prevent bimetallic corrosion.
- If you cannot attach the outdoor unit to the base, secure it from the side or to an additional structure.

**Figure 10. Bolt hole sizes and locations for mounting the outdoor unit**

**Notes:**

- Units: inch
- Refer to [Table 8](#) for A and B.
- Refer to the blueprints in the technical data book for hole specifications for mounting.



**Table 7. Anchor specification**

Size (M)	Drill bit diameter (a)	Anchor length (b)	Sleeve length (c)	Insertion depth	Fastening torque
M10	1/2 in.	3 in.	1-1/2 in.	2 in.	265-1/2 in-lbf

**Table 8. Unit and bolt dimensions**

Dimensions	4TV*072*****	4TV*096/120/144/168/192*****
A: Unit width	37 in.	53-1/8 in.
B: Distance between bolts	29-1/8 in.	45-1/4 in.

## Condenser Discharge Air Duct (optional)

### ⚠ CAUTION

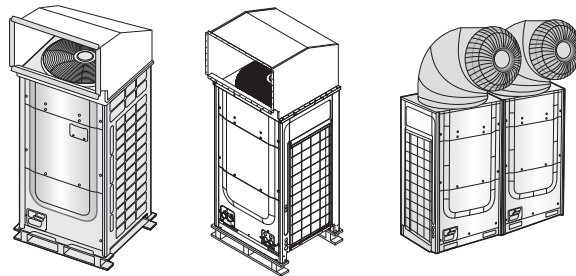
#### Sharp Edges!

Working with galvanized sheet metal involves working with sharp edges. To avoid being cut, technicians **MUST** put on all necessary Personal Protective Equipment (PPE), including gloves and arm guards.

If you remove the fan guard to install the discharge duct, make sure to install a safety net on the duct outlet to prevent foreign substances from entering the unit and to prevent the risk of personal injury from sharp fan blades.

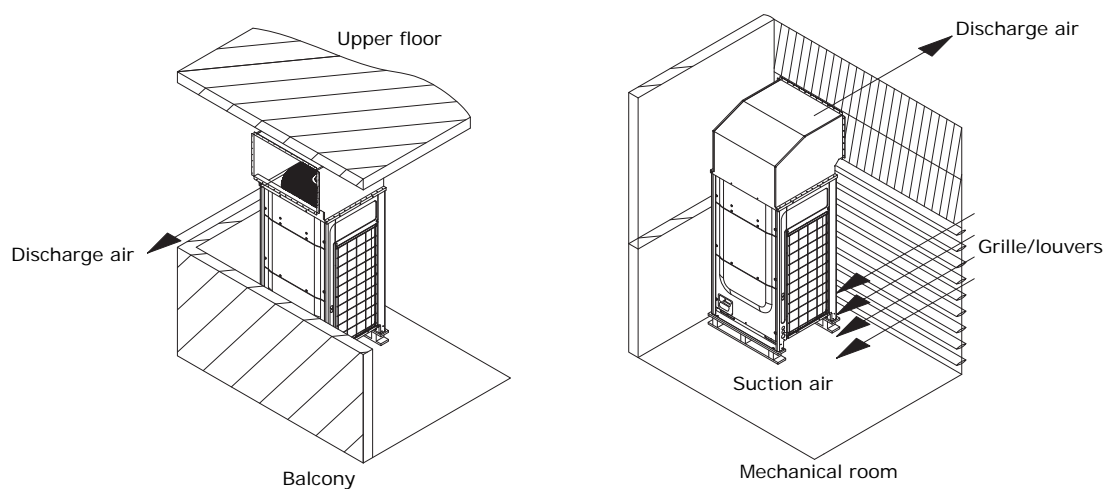
A discharge duct can be installed on the outdoor unit to prevent foreign substances from entering the unit.

The static pressure of the discharge duct should be within the standard specification of 0.32 inches of water when installing the duct.



Examples of condenser discharge air ducts

If it is difficult to provide a minimum of 6.56 ft of space between the air outlet and nearby obstacles, direct the discharge air horizontally from the fan.



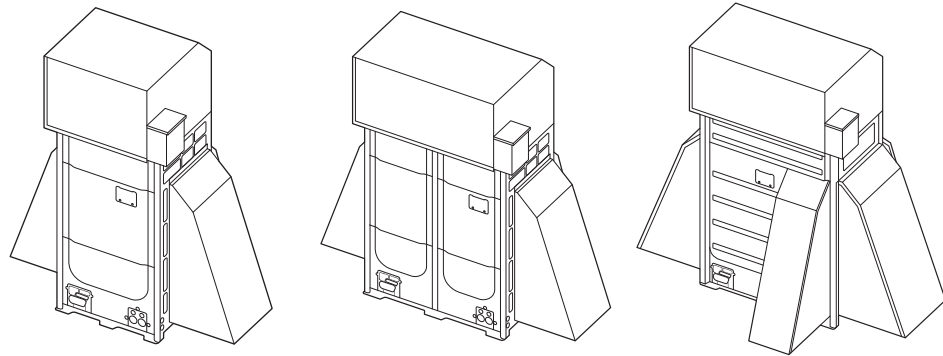
## Wind Baffle/Discharge Air Hood (optional)

A wind baffle should be installed:

- To prevent snow from accumulating on the outdoor unit which may interfere with normal heating or cooling operation.
- To protect the unit from humid air, such as near a sea shore.

Install the baffle so that:

- The discharge air and prevailing wind are not going the same direction.
- The discharge air is not directed to the enclosed area.
- The height (**h**) of the frame or base should be a minimum of 12 inches plus the additional height of the heaviest expected snowfall. (Example: If the base height is the minimum 12 inches and the heaviest expected snow load is 6 inches, then  $h = 12 \text{ inches} + 6 \text{ inches} = 18 \text{ inches}$ ).



# Refrigerant Piping

This section contains information on selecting, storing, and connecting refrigerant piping.

## Selecting Refrigerant Piping

The VRF Selection Software calculates refrigeration piping diameters, associated capacity losses, and additional refrigerant charge based on Type ACR copper tubing. It is recommended to use insulated, unwelded, degassed, and deoxidized copper ACR pipe (Cu-DHP type according to ISO 1337 or UNI EN 12735-1) suitable for an operating pressure of at least 609.15 psi and a burst pressure of at least 3002.28 psi. Alternative refrigeration piping is addressed in document VRF-APG001A-EN, *Alternative VRF Refrigerant Pipe and/or Assembly Methods*. Copper pipe for hydro-sanitary applications is unsuitable.

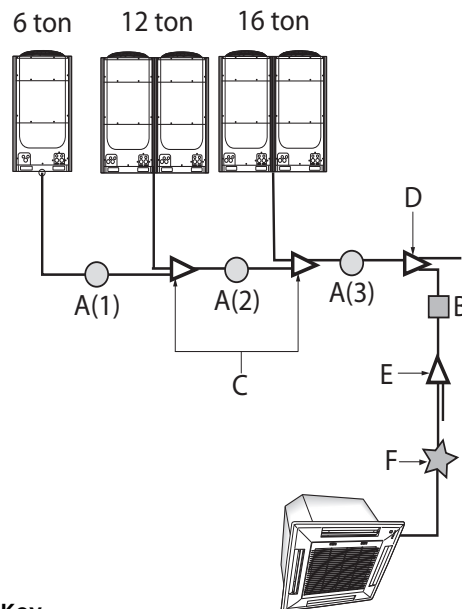
1. Select refrigerant piping according to length. Consider maximum piping length and height differences (Table 24, p. 39 or Table 26, p. 43).
2. Determine pipe and Y-joint size (see “Heat Pump Applications” p. 24” or “Heat Recovery Applications” p. 27).

**Note:** If there is a risk of decreased performance caused by pipe length, use piping that is one size larger in diameter than what is specified in this section.

## Heat Pump Applications

Figure 11 shows an example of a typical 34-ton capacity heat pump application. In this module installation example, all pipes and Y-joints are identified. Table 9, p. 25 through Table 10, p. 26 show how to determine their sizes.

**Figure 11. Typical heat pump system installation, example 1**



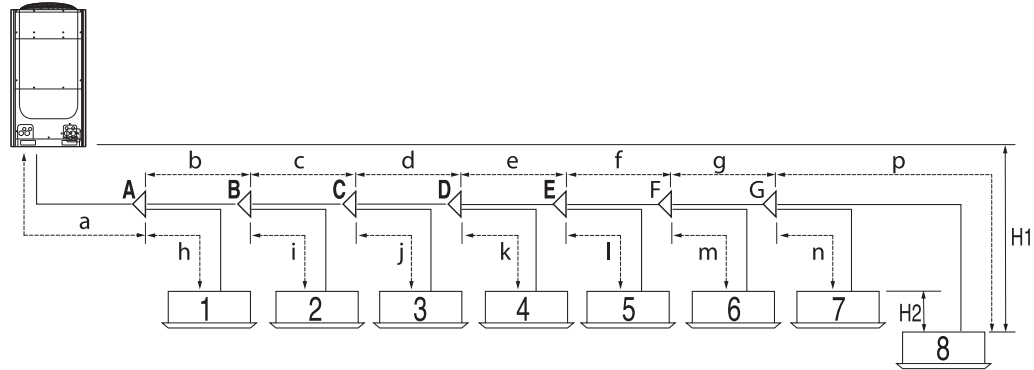
### Key

- A(1), A(2), A(3): Main pipes (Table 9, p. 25).
- B: Pipe size between Y-joints (Table 10, p. 26).
- C: Y-joints between outdoor units (Table 11, p. 26).
- D: First Y-joint according to outdoor unit capacity (Table 12, p. 26).
- E: Y-joints connected after the first branch, according to indoor unit capacity (Table 13, p. 26).
- F: Pipe size between Y-joints and indoor units (Table 14, p. 27).

The capacity of the outdoor unit(s), in addition to the distance from the outdoor unit to the furthest indoor unit (8 in Figure 12), is used to determine the diameter of the main pipe (A in Figure 12).



Figure 12. Typical heat pump system installation, example 2



Use Table 9 to determine the diameter of the main pipe. If distance  $a+b+c+d+e+f+g+p > 295.3$  ft, the main pipe (A in Figure 12) must be upsized.

Table 9. Outdoor unit main pipe size based on distance from outdoor unit to furthest indoor unit (A)

Outdoor unit capacity		Main pipe size (OD) when distance from outdoor unit to furthest indoor unit is $\leq 295.3$ ft		Main pipe size (OD) when distance from outdoor unit to furthest indoor unit $> 295.3$ ft	
		Liquid in.	Gas in.	Liquid in.	Gas in.
Ton	MBH				
6	72	3/8	3/4	1/2	7/8
8	96	3/8	7/8	1/2	1 <sup>(a)</sup>
10	120	1/2	1-1/8	5/8	1-1/8
12	144	1/2	1-1/8	5/8	1-1/4 <sup>(b)</sup>
14	168	5/8	1-1/8	3/4	1-1/4 <sup>(b)</sup>
16	192	5/8	1-1/8	3/4	1-1/4 <sup>(b)</sup>
18	216	5/8	1-1/8	3/4	1-1/4 <sup>(b)</sup>
20	240	5/8	1-1/8	3/4	1-1/4 <sup>(b)</sup>
22	264	3/4	1-3/8	7/8	1-1/2 <sup>(c)</sup>
24	288	3/4	1-3/8	7/8	1-1/2 <sup>(c)</sup>
26	312	3/4	1-3/8	7/8	1-1/2 <sup>(c)</sup>
28	336	3/4	1-3/8	7/8	1-1/2 <sup>(c)</sup>
30	360	3/4	1-5/8	7/8	1-5/8
32	384	3/4	1-5/8	7/8	1-5/8
34	408	3/4	1-5/8	7/8	1-5/8
36	432	3/4	1-5/8	7/8	1-5/8
38	456	3/4	1-5/8	7/8	1-5/8
40	480	3/4	1-5/8	7/8	1-5/8
42	504	3/4	1-5/8	7/8	1-5/8
44	528	3/4	1-5/8	7/8	1-5/8

(a) If 1 in. pipe is not available on site, use 1-1/8 in. pipe.  
 (b) If 1-1/4 in. pipe is not available on site, use 1-3/8 in. pipe.  
 (c) If 1-1/2 in. pipe is not available on site, use 1-5/8 in. pipe.

## Refrigerant Piping

Use [Table 10](#) to determine pipe size between Y-joints (B in [Figure 11](#), p. 24).

**Table 10. Pipe size between indoor Y-joints (B)**

Indoor unit total capacity (MBH)	Branch pipe size (OD) when pipe is < 147.6 ft		Branch pipe size (OD) when pipe is 147.6–295.3 ft	
	Liquid (in.)	Gas (in.)	Liquid (in.)	Gas (in.)
≤ 51	3/8	5/8	1/2	3/4
>51–76	3/8	3/4	1/2	7/8
>76–96	3/8	7/8	1/2	1 <sup>(a)</sup>
>96–136	1/2	1-1/8	5/8	1-1/8
>136–154	1/2	1-1/8	5/8	1-1/4 <sup>(b)</sup>
>154–240	5/8	1-1/8	3/4	1-1/4 <sup>(b)</sup>
>240–336	3/4	1-3/8	7/8	1-1/2 <sup>(c)</sup>
>336–461	3/4	1-5/8	7/8	1-5/8
>461–577	3/4	1-5/8	7/8	2-1/8
>577	7/8	2-1/8	1 <sup>(a)</sup>	2-1/8

(a) If 1 in. pipe is not available on site, use 1-1/8 pipe.

(b) If 1-1/4 in. pipe is not available on site, use 1-3/8 pipe.

(c) If 1-1/2 in. pipe is not available on site, use 1-5/8 pipe.

Use [Table 11](#), [Table 12](#), and [Table 13](#) to select Y-joints (C, D, and E in [Figure 11](#), p. 24).

**Table 11. Outdoor Y-joint between outdoor units (C)**

Outdoor unit capacity (tons)	Model
6–38	4TDK3819B0000A
40–44	4TDK4422B0999A

**Table 12. First indoor Y-joint according to outdoor unit capacity (D)**

Outdoor unit capacity (tons)	Model
6–10	4YDK2512B0138A
12	4YDK2812B0160A
14–20	4YDK2815B0240A
22–28	4YDK3419B0336A
30–38	4YDK4119B0468A
40–44	4YDK4422B0999A

**Table 13. Y-joints connected after the first Y-joint, according to total indoor unit capacity (E)**

Total indoor unit capacity (MBH) <sup>(a)</sup>	Model
≤ 51	4YDK1509B0051A
>51–136	4YDK2512B0138A
>136–154	4YDK2812B0160A
>154–240	4YDK2815B0240A
>240–336	4YDK3419B0336A
>336–461	4YDK4119B0468A
> 461	4YDK4422B0999A

(a) Indoor Y-joints are selected based on downstream indoor unit capacity: the first indoor Y-joint will be the largest, the second indoor Y-joint will be smaller, and so on.

Use [Table 14](#) to determine pipe size between indoor Y-joints and indoor units (F in [Figure 18](#), p. 37).

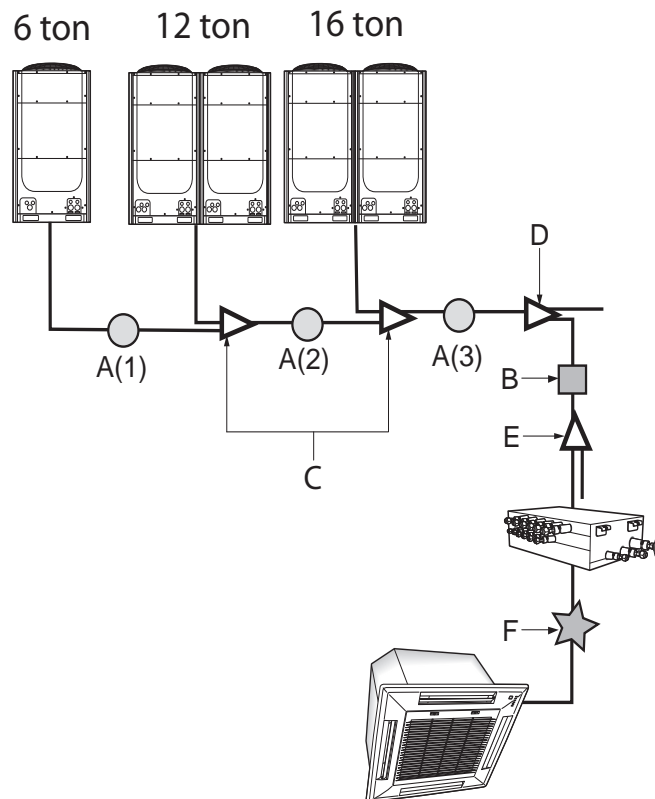
**Table 14. Pipe size between the indoor Y-joint and indoor unit (F)**

Indoor unit capacity (MBH)	Pipe size (OD)	
	Liquid in.	Gas in.
≤ 20	1/4	1/2
>20-55	3/8	5/8
>55-78	3/8	3/4
>78-96	3/8	7/8

## Heat Recovery Applications

[Figure 13](#) shows an example of a 34-ton capacity heat recovery application. In this module installation example, all pipes and Y-joints are identified. [Table 15](#), p. 28 through [Table 20](#), p. 30 show how to determine their sizes.

**Figure 13. Typical heat recovery system installation, example 1**



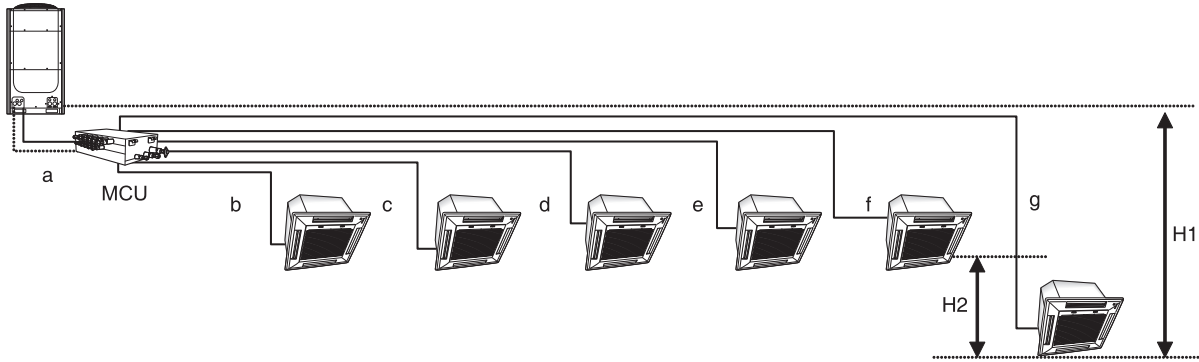
### Key

- A(1), A(2), A(3): Main pipes ([Table 15](#), p. 28).
- B: Pipe size between Y-joint and MCU ([Table 16](#), p. 29).
- C: Outdoor Y-joints between outdoor units ([Table 17](#), p. 29).
- D: First Y-joint according to outdoor unit capacity ([Table 18](#), p. 29).
- E: Y-joints connected to MCUs or other Y-joints ([Table 19](#), p. 30).
- F: Pipe size between MCUs and indoor units ([Table 20](#), p. 30).

## Refrigerant Piping

The capacity of the outdoor unit(s), in addition to the distance from the outdoor unit to the furthest indoor unit ("g" in Figure 14), is used to determine the diameter of the main pipe (A in Figure 14).

**Figure 14. Typical heat recovery system installation, example 2**



Use Table 15 to determine the diameter of the main pipe. If distance a+g > 295.3 ft, the main pipe (A in Figure 14) must be upsized.

**Table 15. Outdoor unit main pipe size based on distance from outdoor unit to furthest indoor unit (A)**

Outdoor unit capacity		Main pipe size (OD) when distance from outdoor unit to furthest indoor unit is ≤ 295.3 ft (90 m)			Main pipe size (OD) when distance from outdoor unit to furthest indoor unit > 295.3 ft (90 m)		
		Liquid in.	Gas in.	High- pressure gas in.	Liquid <sup>(a)</sup> in.	Gas in.	High- pressure gas in.
Ton	MBH						
6	72	3/8	3/4	5/8	1/2	3/4	5/8
8	96	3/8	7/8	3/4	1/2	7/8	3/4
10	120	1/2	1-1/8	7/8	5/8	1-1/8	7/8
12	144	1/2	1-1/8	7/8	5/8	1-1/8	7/8
14	168	5/8	1-1/8	7/8	3/4	1-1/8	7/8
16	192	5/8	1-1/8	1-1/8	3/4	1-1/8	1-1/8
18	216	5/8	1-1/8	1-1/8	3/4	1-1/8	1-1/8
20	240	5/8	1-1/8	1-1/8	3/4	1-1/8	1-1/8
22	264	3/4	1-3/8	1-1/8	7/8	1-3/8	1-1/8
24	288	3/4	1-3/8	1-1/8	7/8	1-3/8	1-1/8
26	312	3/4	1-3/8	1-1/8	7/8	1-3/8	1-1/8
28	336	3/4	1-3/8	1-1/8	7/8	1-3/8	1-1/8
30	360	3/4	1-5/8	1-3/8	7/8	1-5/8	1-3/8
32	384	3/4	1-5/8	1-3/8	7/8	1-5/8	1-3/8
34	408	3/4	1-5/8	1-3/8	7/8	1-5/8	1-3/8
36	432	3/4	1-5/8	1-3/8	7/8	1-5/8	1-3/8
38	456	3/4	1-5/8	1-3/8	7/8	1-5/8	1-3/8
40	480	3/4	1-5/8	1-3/8	7/8	1-5/8	1-3/8
42	504	3/4	1-5/8	1-3/8	7/8	1-5/8	1-3/8
44	528	3/4	1-5/8	1-3/8	7/8	1-5/8	1-3/8

(a) Increase the liquid pipe by one size if the pipe length > 295.3 ft, as specified in this column.

Use Table 16 to determine pipe size between Y-joints (B in Figure 13, p. 27).

**Table 16. Pipe size between indoor Y-joints, and between the indoor Y-joint and the MCU (B)**

Indoor unit total capacity (MBH)	Branch pipe size (OD) when pipe is < 147.6 ft			Branch pipe size (OD) when pipe is 147.6-295.3 ft		
	Liquid in.	Gas in.	High-pressure gas in.	Liquid in.	Gas in.	High-pressure gas in.
≤ 51	3/8	5/8	5/8	1/2	3/4	5/8
>51-76	3/8	3/4	5/8	1/2	7/8	5/8
>76-96	3/8	7/8	3/4	1/2	1 <sup>(a)</sup>	3/4
>96-115	1/2	1-1/8	3/4	5/8	1-1/8	3/4
>115-136	1/2	1-1/8	7/8	5/8	1-1/8	7/8
>136-154	1/2	1-1/8	7/8	5/8	1-1/4 <sup>(b)</sup>	7/8
>154-172	5/8	1-1/8	7/8	3/4	1-1/4 <sup>(b)</sup>	7/8
>172-240	5/8	1-1/8	1-1/8	3/4	1-1/4 <sup>(b)</sup>	1-1/8
>240-336	3/4	1-3/8	1-1/8	7/8	1-1/2 <sup>(c)</sup>	1-1/8
>336-461	3/4	1-5/8	1-3/8	7/8	1-5/8	1-3/8
461-577	3/4	1-5/8	1-3/8	7/8	2-1/8	1-3/8
> 577	7/8	2-1/8	1-5/8	1 <sup>(a)</sup>	2-1/8	1-5/8

- (a) If 1 in. pipe is not available on site, use 1-1/8 pipe.
- (b) If 1-1/4 in. pipe is not available on site, use 1-3/8 in. pipe.
- (c) If 1-1/2 in. pipe is not available on site, use 1-5/8 in. pipe.

Use Table 17, Table 18, and Table 19 to select Y-joints (C, D, and E in Figure 13, p. 27).

**Table 17. Outdoor Y-joint between outdoor units (C)**

Y-joint between outdoor units (C)	Outdoor unit capacity (ton)	Model
For low-pressure gas and liquid lines	6-38	4TDK3819B0000A
	40-44	4TDK4422B0999A
For high-pressure gas line	6-38	4TDK3100B0000A
	40-44	4TDK3800B0999A

**Table 18. First Y-joint according to outdoor unit capacity (D)**

First indoor Y-joint (D)	Outdoor unit capacity (ton)	Model
For low-pressure gas and liquid lines	6-10	4YDK2512B0138A
	12	4YDK2812B0160A
	14-20	4YDK2815B0240A
	22-28	4YDK3419B0336A
	30-38	4YDK4119B0468A
	40-44	4YDK4422B0999A
For high-pressure gas line	6	4YDK1500B0080A
	8-20	4YDK2500B0240A
	22-38	4YDK3100B0468A
	40-44	4YDK3800B0999A

## Refrigerant Piping

**Table 19. Indoor Y-joint between MCUs or another Y-joint (E)**

Y-joints after the first Y-joint (E)	Total indoor unit capacity (MBH) (a)	Model
Indoor Y-joint	≤ 51	4YDK1509B0051A
	>51–136	4YDK2512B0138A
	>136–154	4YDK2812B0160A
	>154–240	4YDK2815B0240A
	>240–336	4YDK3419B0336A
	>336–461	4YDK4119B0468A
	>461	4YDK4422B0999A
High-pressure gas Y-joint (for heat recovery models)	≤ 76	4YDK1500B0080A
	>76–240	4YDK2500B0240A
	>240–461	4YDK3100B0468A
	>461	4YDK3800B0999A

(a) Y-joints are selected based on downstream indoor unit capacity (first Y-joint will be largest, second Y-joint may be smaller, and so on).

Use [Table 20](#) to determine pipe size between Y-joints and MCUs (F in [Figure 13](#), p. 27).

**Table 20. Pipe size between MCUs and indoor units (F)**

Indoor unit capacity (MBH)	Pipe size (OD) (F)	
	Liquid in.	Gas in.
≤ 20	1/4	1/2
>20-55	3/8	5/8
>55-78	3/8	3/4
>78-96	3/8	7/8

## Pipe Thickness and Temper Grade

[Table 21](#) specifies pipe minimum thickness and temper grade based on pipe diameter.

**⚠ CAUTION**

**Risk of Pipes Breaking!**

If pipes with a diameter larger than 3/4 in. are specified, use semi-hard (C1220T-1/2H) or hard (C1220T-H) copper piping. If a softer copper pipe (C1220T-O) is used, the pipe may break due to its low pressure resistance and cause personal injury.

**Table 21. Refrigerant pipe minimum thickness and temper grade**

Outer diameter in.	Minimum thickness in.	Temper grade
1/4	0.028	Annealed (C1220T-O)
3/8	0.028	
1/2	0.031	
5/8	0.039	

**Table 21. Refrigerant pipe minimum thickness and temper grade (continued)**

Outer diameter in.	Minimum thickness in.	Temper grade
3/4	0.035	Drawn (C1220T-1/2H or C1220T-H)
7/8	0.035	
1	0.039	
1-1/8	0.043	
1-1/4	0.043	
1-3/8	0.048	
1-1/2	0.053	
1-5/8	0.056	
1-3/4	0.063	
2	0.079	
2-1/8	0.083	

## Storing Refrigerant Piping

To prevent foreign materials or water from entering the pipe, storing method and sealing method (especially during installation) is very important. Apply correct sealing method depending on the environment (see [Table 22](#)).

**Table 22. Refrigerant pipe storage factors**

Storage location	Storage time	Sealing type
Outdoor	Longer than one month	Pipe pinch
	Shorter than one month	Taping
Indoor	—	Taping

## Installing Refrigerant Piping

### **⚠ WARNING**

#### **Hazard of Explosion and Deadly Gases!**

Failure to follow all proper safe refrigerant handling practices could result in death or serious injury. Never solder, braze or weld on refrigerant lines or any unit components that are above atmospheric pressure or where refrigerant may be present. Always remove refrigerant by following the guidelines established by the EPA Federal Clean Air Act or other state or local codes as appropriate. After refrigerant removal, use dry nitrogen to bring system back to atmospheric pressure before opening system for repairs. Mixtures of refrigerants and air under pressure may become combustible in the presence of an ignition source leading to an explosion. Excessive heat from soldering, brazing or welding with refrigerant vapors present can form highly toxic gases and extremely corrosive acids.

### **NOTICE:**

#### **System Component Damage!**

Do not remove the seal caps from refrigerant connections or open the service valves until you are prepared to braze refrigerant lines to the connections. Excessive exposure to atmosphere (> 5 min.) may allow moisture or dirt to contaminate the system, damaging valve seals and causing ice formation in system components.

## Refrigerant Piping

### Overview

1. Cut or extend field-supplied piping as needed. To extend pipes, braze or using flared pipe connections (not supplied). Refer to “Pipe Cutting” p. 32, “Nitrogen Flushing While Brazing” p. 32, and “Flared Pipe Connections” p. 33.)
2. Make sure that pipes are free of dirt, debris, and moisture, and do not leak. (Refer to “Leak Testing Pipe Connections” p. 54).
3. Braze or use flared pipe connections to install piping. Refer to “Connecting Piping to the Outdoor Unit” p. 34) and to “Connecting Outdoor Units with Y-joints” p. 35.

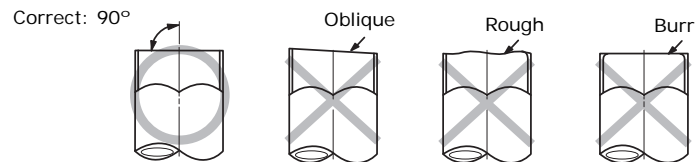
### Pipe Cutting

Required tools:

- Pipe cutter
- Reamer
- Pipe holder

1. Using a pipe cutter, cut the pipe so that the cut edge is at 90° to the side of the pipe.
2. Use a reamer to remove all burrs at the cut edge.

See examples of correctly and incorrectly cut pipes.



### Nitrogen Flushing While Brazing

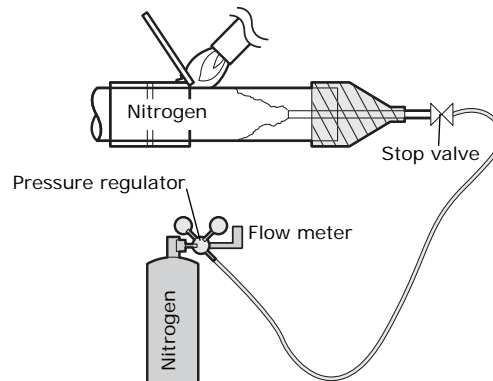
#### **NOTICE**

#### **Avoid Unit Damage!**

**Never braze pipe connections without performing nitrogen flushing. Failure to perform this procedure will damage the unit, resulting in capacity loss and reduced long-term reliability.**

While brazing refrigerant pipes, flush them with nitrogen gas. Use a pressure regulator to maintain a flow rate of 1.76 ft<sup>3</sup>/h or more.

**Figure 15. Nitrogen flushing while brazing refrigerant pipes**





## Flared Pipe Connections

Clutch type and wing nut type flare tools are available for flared pipe connections.

1. Slide the flare nut over the pipe to be flared.
2. Slide the end of the pipe into the hole on the flaring bar that fits the pipe, leaving a length of pipe, determined by tool type (Figure 16), extending above the flaring bar. Clamp it down.

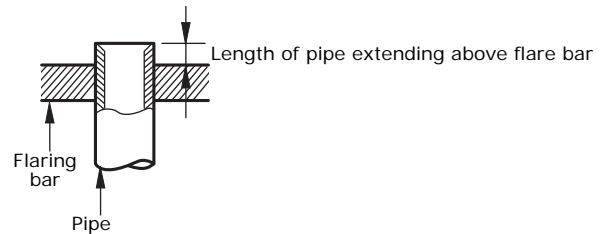

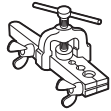
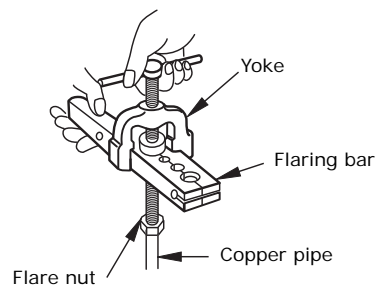


Figure 16. Flaring tools

R-410A clutch type	Conventional flare tool	
	Clutch type	Wing nut type
0–0.020 in.	0.04–0.06 in.	0.06–0.08 in.
		

3. Attach the yoke to the flaring bar, centering the conical part over the end of the pipe that is extending above the flaring bar.
4. Tighten the yoke securely to flare the end of the pipe.



5. Remove the pipe. The end of the pipe that you flared should look like the end of a trumpet. See examples of correctly and incorrectly flared pipes.



## Refrigerant Piping

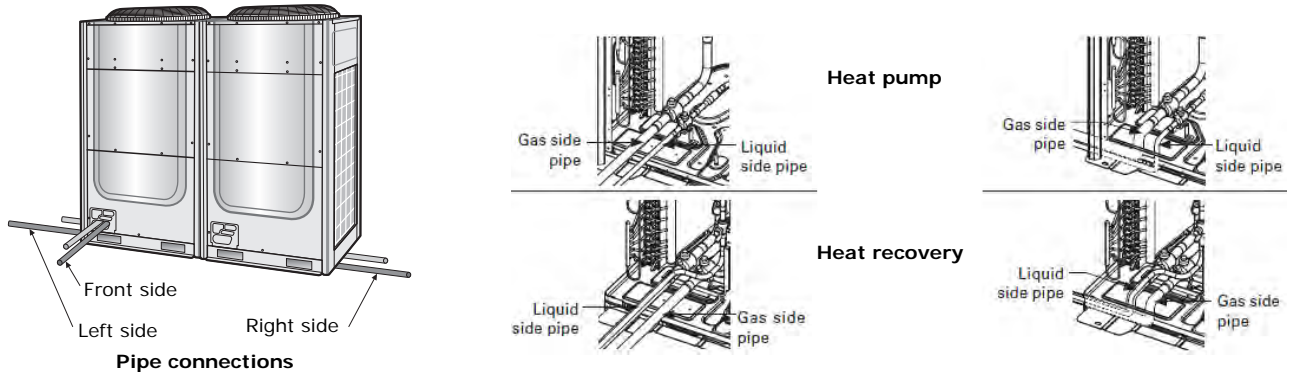
- Align the pipes and tighten the flare nuts manually and then with a spanner torque wrench, applying the torque according to pipe dimensions:

Outer diameter in.	Connection torque (ft·lb)	Flare dimension (in.)	Flare shape (in.)
1/4	10.3–13.3 ft·lb	0.34–0.36	
3/8	25.1–31.0 ft·lb	0.50–0.52	
1/2	36.1–45.0 ft·lb	0.64–0.65	
5/8	50.2–60.5 ft·lb	0.76–0.78	

## Connecting Piping to the Outdoor Unit

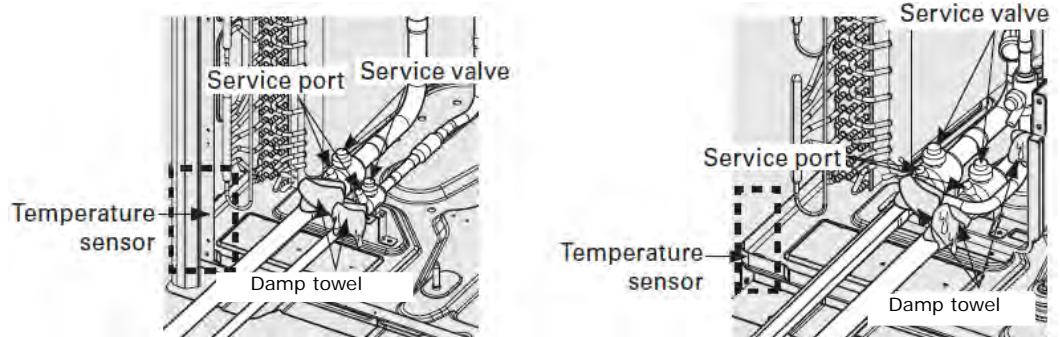
**Important:** Ensure that all pipe connections are accessible for servicing and maintenance.

Pipes can be connected to the outdoor unit at the front, bottom left, or bottom right of the unit, as shown in the following figure:



- Remove the pipe cover from the outdoor unit.
- Remove the knock-outs that you are going to use. Unused knock-outs should remain closed to prevent damage to the unit.
  - Take care to prevent damage to the exterior of the unit.
  - Remove burrs from knock-out hole edges and apply rust inhibitor.
- Connect the pipes to the outdoor unit using flared connections or by brazing. If brazing the pipe connection, avoid damaging the service valve by wrapping it with a wet cloth as shown in [Figure 17, p. 35](#).
  - Avoid damaging the temperature sensor.
  - Ensure that the connected pipes do not touch each other or make contact with the unit.
- After making electrical connections (see [“Electrical Wiring” p. 45](#)) and insulating the pipes (see [“Insulating Refrigerant Pipes” p. 58](#)), replace the pipe cover and close the remaining gap.

Figure 17. Protecting the unit and temperature sensor while brazing the pipe connection



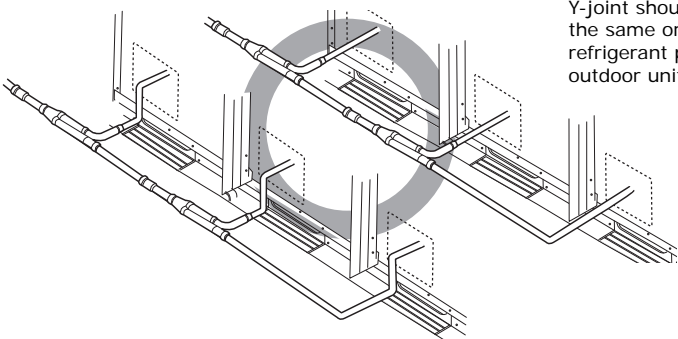
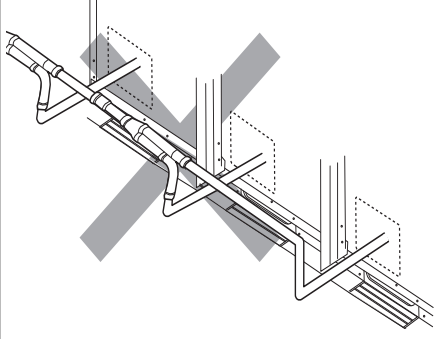
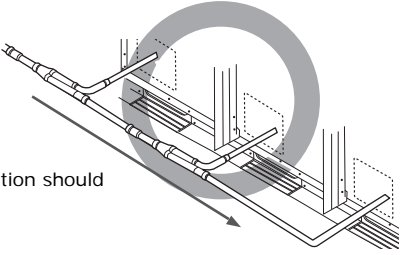
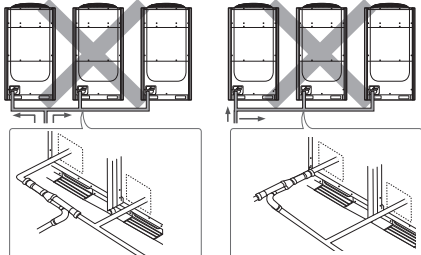
### Connecting Outdoor Units with Y-joints

**Important:** Ensure that all pipe connections are accessible for servicing and maintenance. For optimal refrigerant distribution, use only factory joints.

Install outdoor Y-joints as needed to connect multiple outdoor units to one another (refer to Table 23). Install Y-joints as needed to connect outdoor units to indoor units. See the branch joint installation manual (VRF-SVN41) for details.

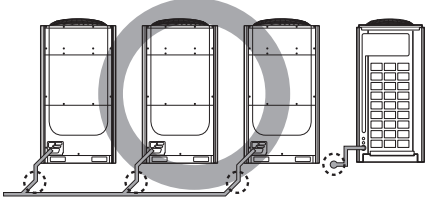
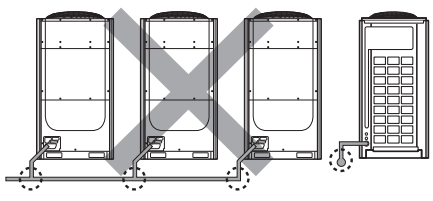
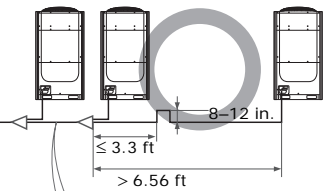
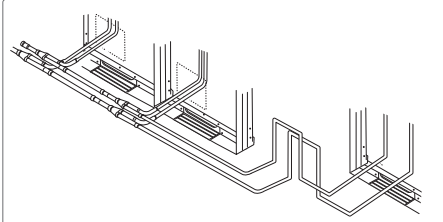
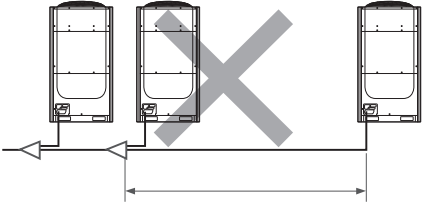
**Note:** Outdoor units can be installed in any order.

Table 23. Connecting outdoor units with Y-joints

Correct installation	Incorrect installation
 <p>Y-joint should be connected at the same or lower level as the refrigerant pipes leaving the outdoor unit.</p>	
<p>Refrigerant pipes must be connected in parallel with the unit.</p>  <p>Unit straight section should be <math>\geq 12</math> in.</p>	

# Refrigerant Piping

**Table 23. Connecting outdoor units with Y-joints (continued)**

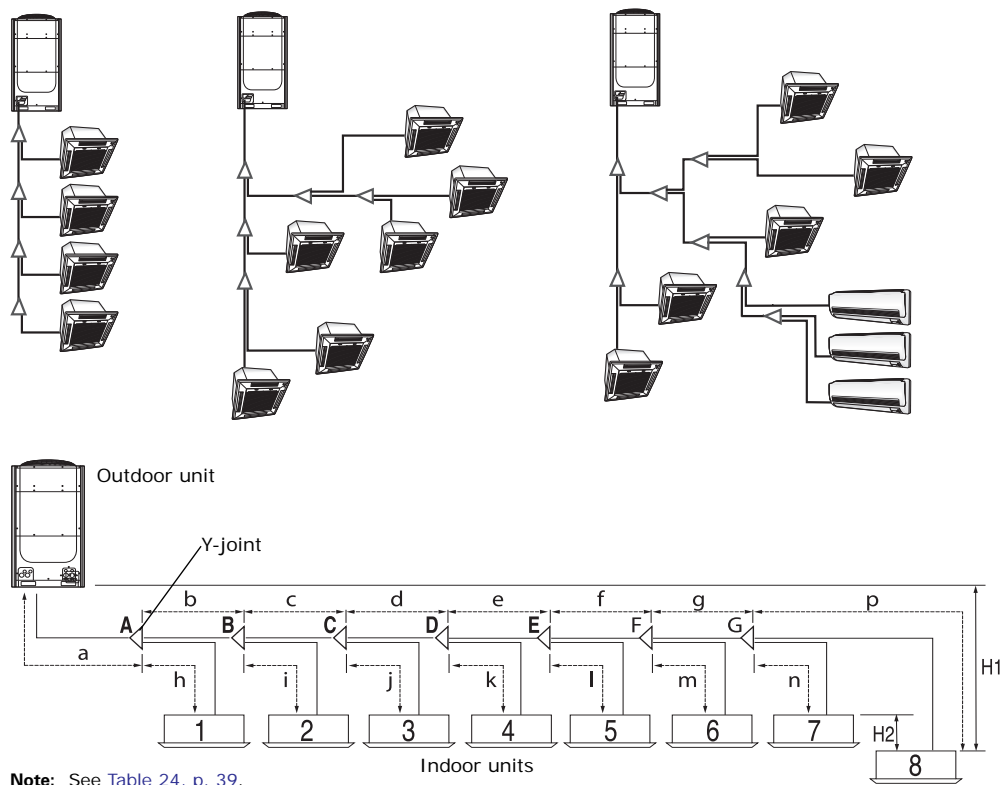
Correct installation	Incorrect installation
<p>Y-joints between outdoor units must be installed horizontally.</p> 	
 <p>If the piping length between the outdoor unit and the Y-joint exceeds 6.56 ft, install a vertical trap that is 8–12 in. high.</p> 	

## Refrigerant Piping Installation Examples: Heat Pump

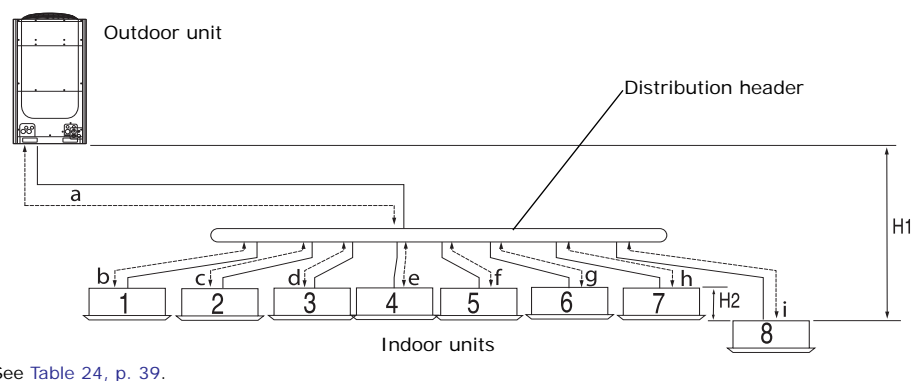
**Notes:**

- Y-joints are preferred over distribution headers. Distribution headers should be used only if unable to meet a minimum of 19-1/2 inches of straight piping entering a Y-joint.
- Install indoor units from largest to smallest capacity starting at the inlet of the distribution header.
- If there are unused ports on a distribution header, pinch off the ports first that are closest to the inlet.

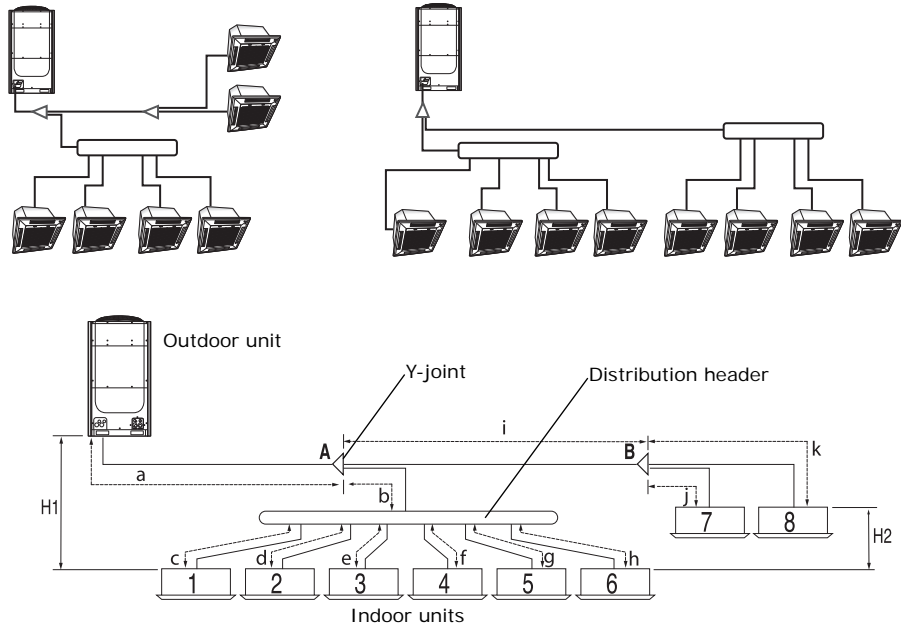
**Figure 18. Single installations with Y-joints: Heat pump**



**Figure 19. Single installation with distribution header: Heat pump**

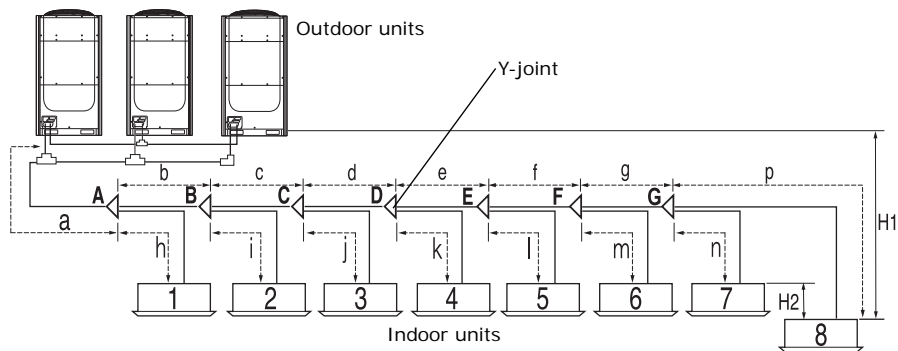


**Figure 20. Single installations with Y-joint and distribution header: Heat pump**



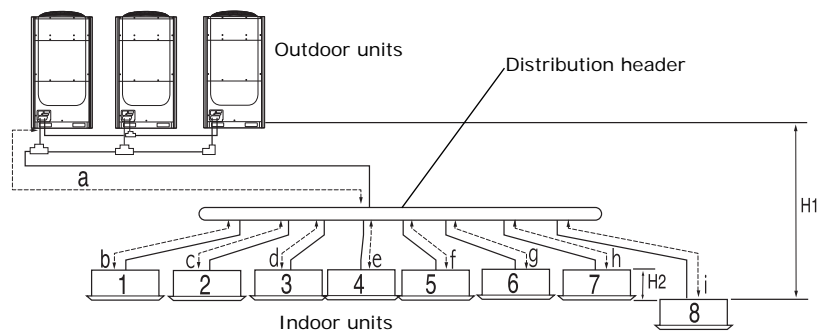
Note: See Table 24, p. 39.

**Figure 21. Module installation with Y-joint: Heat pump**



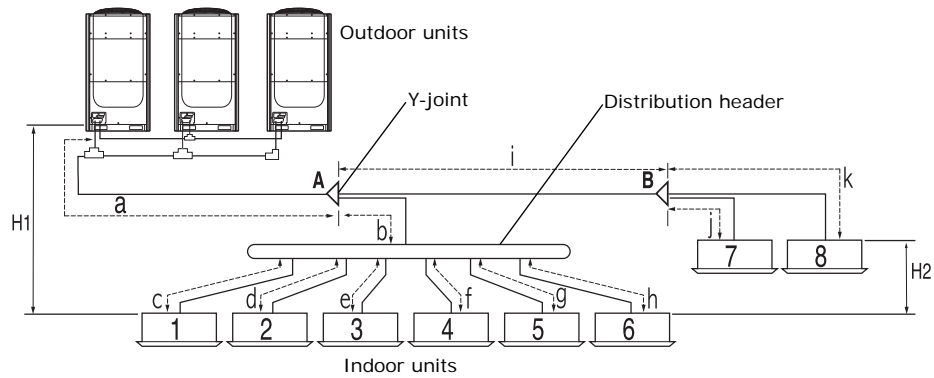
Note: See Table 24, p. 39.

**Figure 22. Module installation with distribution header: Heat pump**



Note: See Table 24, p. 39.

Figure 23. Module installation with Y-joint and distribution header: Heat pump



Note: See Table 24, p. 39.

Table 24. Maximum allowable refrigerant piping length and height differences for heat pump installations

	Piping location	Piping length and height difference maximums (ft)		Notes/Examples	
Maximum allowable piping length	Outdoor unit to indoor unit	Actual piping length [equivalent length] <sup>(a)</sup>	656 [722] ft	Y-joint only	$a+b+c+d+e+f+g+p \leq 656$ [722] ft; see Figure 18, p. 37 and Figure 21, p. 38
				Distribution header only	$a+i \leq 656$ [722] ft; see Figure 19, p. 37 and Figure 22, p. 38
		Total piping length	3281 ft	Y-joint and distribution header	$a+b+h \leq 656$ [722] ft $a+i+k \leq 656$ [722] ft; see Figure 20, p. 38 and Figure 23, p. 39
				Y-joint only	see Figure 18, p. 37 and Figure 21, p. 38
	Between outdoor units (module installation)	Piping length	33 ft	$x \leq 33$ ft, $y \leq 33$ ft, $z \leq 33$ ft	
		Equivalent length	43 ft	$x \leq 43$ ft, $y \leq 43$ ft, $z \leq 43$ ft	
Maximum allowable piping height difference	Outdoor unit to indoor unit	361/361 ft <sup>(b)</sup>		$H1 \leq 361/361$ ft	
	Indoor unit to indoor unit	164 ft		$H2 \leq 164$ ft <sup>(c)</sup>	
Maximum piping length after Y-joint	First Y-joint to farthest indoor unit	Piping length	148 ft	Y-joint only	$b+c+d+e+f+g+p \leq 148$ ft
				Distribution header only	$b+h \leq 148$ ft, $i+k \leq 148$ ft
				Y-joint and distribution header	$i \leq 148$ ft
			148–295 ft <sup>(d)</sup>		
Electronic expansion valve (EEV) kit <sup>(e)</sup>	Indoor unit	Actual piping length	6.6 ft	4EEVEVA32SA000	Applied to indoor units without EEV (wall-mounted)

(a) Equivalent length Y-joint: 1.64 ft (0.5 m); distribution header: 3.28 ft.

- (b) If the indoor unit is at a *higher* level than the outdoor unit, the allowable height difference is 361 ft. If the height difference is >131 ft, request engineering support from Trane. If the indoor unit is located at a *lower* level than the outdoor unit, the allowable height difference is 361 ft. If the height difference is > 164 ft, request engineering support from Trane.
- (c) If 4TVW00\*\*B100N\* is installed, H2 ≤ 49 ft.
- (d) Required conditions must be satisfied (see Table 25, p. 40).
- (e) Required for indoor units that do not have internal EEVs. Refer to the EEV kit installation guide (VRF-SVN43) for detailed information.

**Table 25. Required condition (note to Table 24, p. 39)**

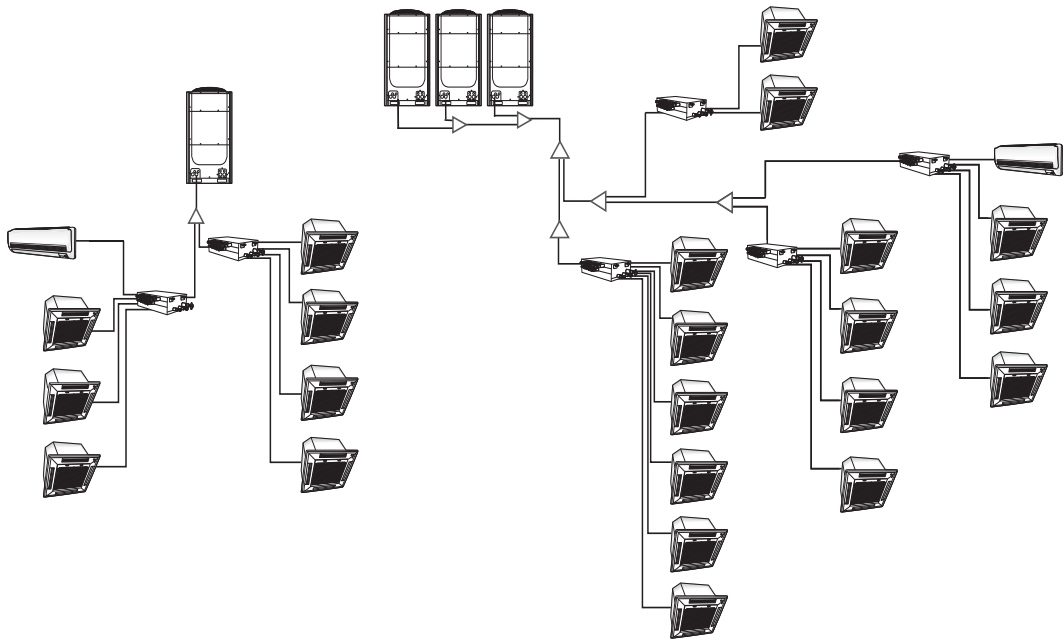
	Condition	Example
First Y-joint to farthest indoor unit	$148 \text{ ft} \leq b+c+d+e+f+g+p \leq 295 \text{ ft}$ : branch pipes (b, c, d, e, f, g) size must be increased by 1 size	
Total length of extended pipe	If the size of the pipe between the first Y-joint and the outdoor unit is <i>not</i> increased by 1 size, $a+(b+c+d+e+f+g) \times 2+h+i+j+k+l+m+n+p \leq 3281 \text{ ft}$	
	If the size of the pipe between the first Y-joint and the outdoor unit is increased by 1 size, $(a+b+c+d+e+f+g) \times 2+h+i+j+k+l+m+n+p > 3281 \text{ ft}$	
Each Y-joint to each indoor unit	$h, i, j, \dots, p \leq 148 \text{ ft}$	
Difference between [distance of the outdoor unit to farthest indoor unit] and [nearest indoor unit] ≤ 148 ft	$(a+b+c+d+e+f+g+p) - (a+h) \leq 148 \text{ ft}$	



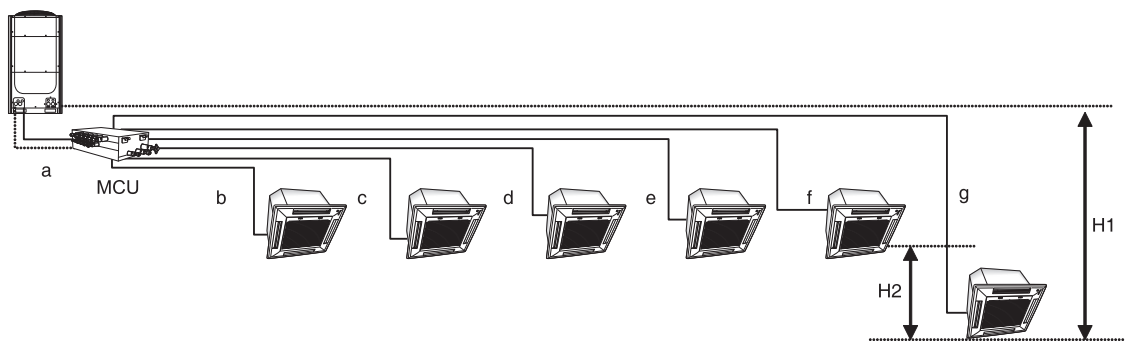
### Refrigerant Piping Installation Examples: Heat Recovery

**Note:** First generation MCUs (models 4MCUCUY\*) and second generation MCUs (models 4MCUTV\*) cannot be mixed on a VRF system.

**Figure 24. Single and module installations with MCUs and Y-joints: Heat recovery**

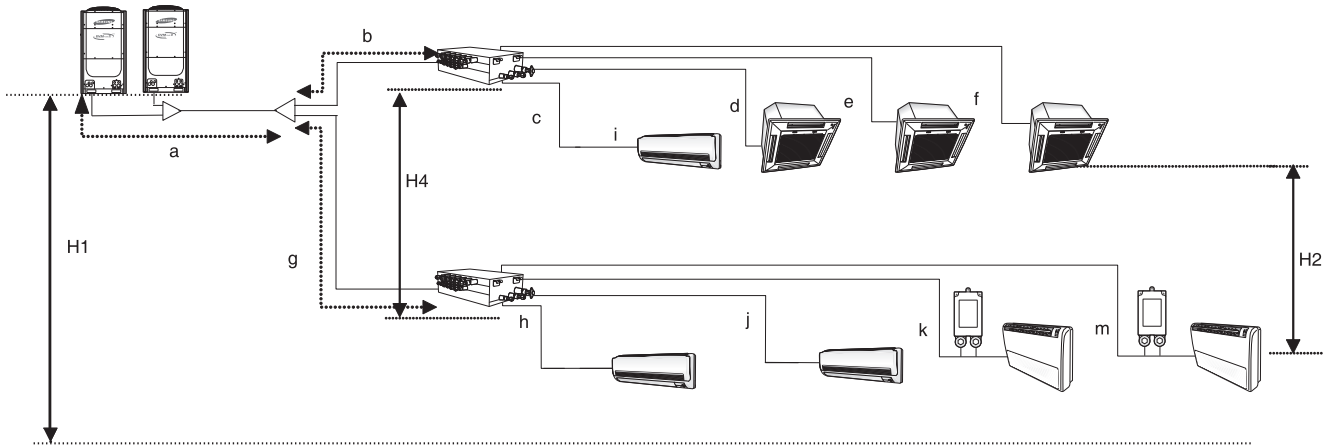


**Figure 25. Single installation with MCU: Heat recovery**

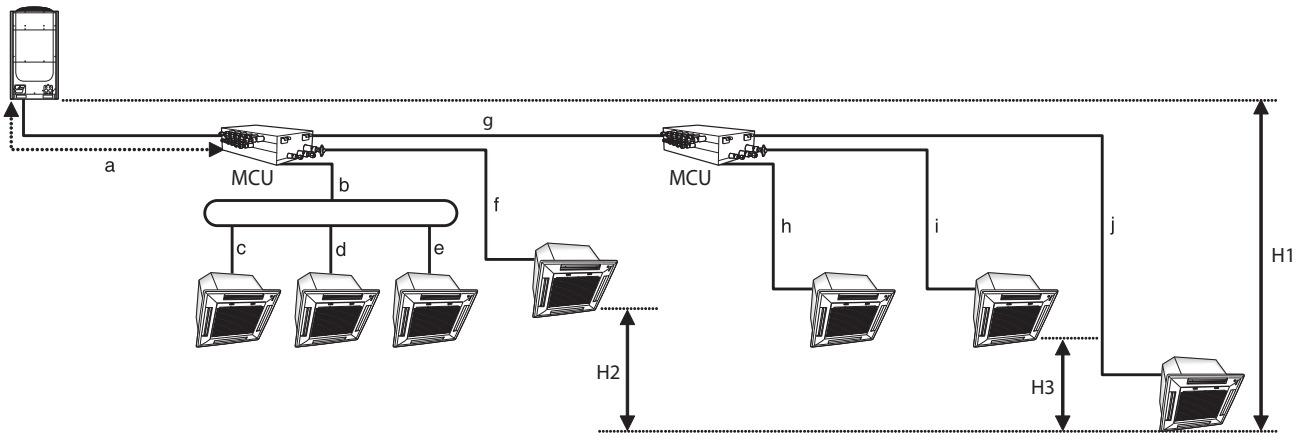


# Refrigerant Piping

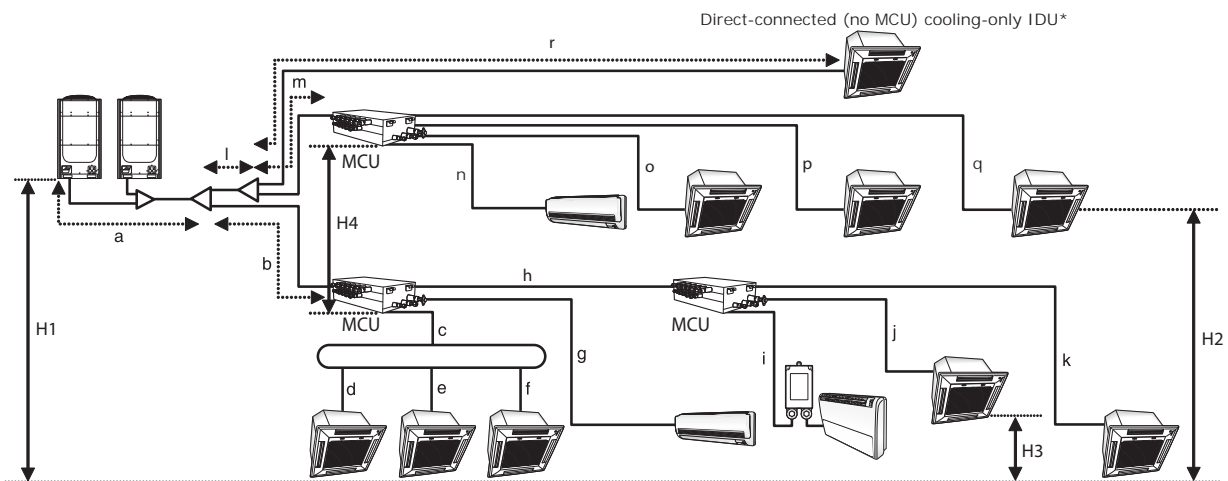
**Figure 26. Module installation with MCUs and Y-joints: Heat recovery**



**Figure 27. Single installation with indoor unit connected in series to MCU**

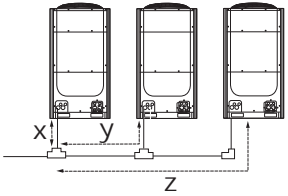


**Figure 28. Module installation with indoor units connected in series to MCU and by Y-joint to MCU**



\*For indoor units to which no MCU is connected, be sure to set their Installation Option #2, Digit 3, to "2": Cooling only enabled, and then connect them to a low-pressure gas pipe and a liquid pipe.

**Table 26. Maximum allowable refrigerant piping length and height differences for heat recovery installations**

	Piping location	Piping length and height difference maximums (ft)		Notes/Examples	
<b>Maximum allowable piping length</b>	Outdoor unit to indoor unit	Actual pipe [equivalent length] <sup>(a)</sup>	656 [722] ft	MCU only	$a+g+j \leq 656$ [722] ft
				Y-joint and MCU	$a+b+h+k \leq 656$ [722] ft
		Total piping length	3281 ft	MCU only	$a+b+c+d+e+f+g+h+i+j \leq 3281$ ft
				Y-joint and MCU	$a+b+c+\dots+r \leq 3281$ ft
	Between outdoor units (module installation)	Piping length	33 ft	$x \leq 33$ ft, $y \leq 33$ ft, $z \leq 33$ ft	
		Equivalent piping length	43 ft	$x \leq 43$ ft, $y \leq 43$ ft, $z \leq 43$ ft	
MCU to indoor unit	Piping length	148 ft	MCU only	$b+c \leq 148$ ft, $b+d \leq 148$ ft, $b+e \leq 148$ ft, $f \leq 148$ ft, $g+h \leq 148$ ft, $g+i \leq 148$ ft, $g+j \leq 148$ ft	
			Y-joint and MCU	$c+d \leq 148$ ft, $c+e \leq 148$ ft, $c+f \leq 148$ ft, $g \leq 148$ ft, $h+i \leq 148$ ft, $h+j \leq 148$ ft, $h+k \leq 148$ ft, $n \leq 148$ ft, $o \leq 148$ ft, $p \leq 148$ ft, $q \leq 148$ ft, $r \leq 148$ ft	
<b>Maximum allowable piping height difference</b>	Outdoor unit to indoor unit	Piping length	361 ft <sup>(b)</sup>	$H1 \leq 361/361$ ft	
	Indoor unit to indoor unit		131 ft	$H2 \leq 131$ ft <sup>(c)</sup>	
	Indoor unit to indoor unit (with 1 MCU)		49 ft	$H3 \leq 49$ ft	
	MCU to MCU		98 ft	$H4 \leq 98$ ft	
<b>Maximum allowable length after branch joint</b>	First Y-joint to farthest indoor unit	Piping length	148 ft	MCU only	$g+j \leq 148$ ft
				Y-joint and MCU	$b+h+k \leq 148$ ft $l+m+q \leq 148$ ft $l+r \leq 148$ ft
			148–295 ft <sup>(d)</sup>		
<b>Electronic expansion valve (EEV) kit<sup>(e)</sup></b>	Indoor unit	Actual piping length	6.6 ft	4EEVEVA32SA000	Applied to indoor units without EEV (wall-mounted)

(a) Equivalent piping length—Y-joint: 1.64 ft; distribution header: 3.28 ft; MCU: 3.28 ft.  
 (b) If the indoor unit is at a *higher* level than the outdoor unit, the allowable height difference is 361 ft. If the height difference is > 131 ft, request engineering support from Trane. If the indoor unit is located at a *lower* level than the outdoor unit, the allowable height difference is 361 ft. If the height difference is > 164 ft, request engineering support from Trane.  
 (c) If 4TVW00\*\*B100N\* is installed,  $H2 \leq 49$  ft.  
 (d) Required conditions must be satisfied (see Table 27, p. 44).  
 (e) Required for indoor units that do not have internal EEVs. Refer to the EEV kit installation guide (VRF-SVN43) for detailed information.

# Refrigerant Piping

**Table 27. Required condition (note to Table 26, p. 43)**

	Condition	Example
First Y-joint to farthest indoor unit	$148 \text{ ft} \leq b+c+d+e+f+g+p \leq 295 \text{ ft}$ : branch pipes (b, c, d, e, f, g) size must be increased by 1 size	
Total length of extended pipe	If the size of the pipe between the first Y-joint and the outdoor unit is <i>not</i> increased by 1 size, $a+(b+c+d+e+f+g) \times 2+h+i+j+k+l+m+n+p \leq 3281 \text{ ft}$ If the size of the pipe between the first Y-joint and the outdoor unit is increased by 1 size, $(a+b+c+d+e+f+g) \times 2+h+i+j+k+l+m+n+p > 3281 \text{ ft}$	
Each MCU to each indoor unit	$c+d, c+e, c+f, g, h+i, h+j, h+k, n, o, p, r \leq 148 \text{ ft}$	
Difference between [the distance of the outdoor unit to the farthest indoor unit] and the [nearest indoor unit] $\leq 148 \text{ ft}$ $(a+b+h+k) - (a+b+c+d) \leq 148 \text{ ft}$		
<p><b>Notes:</b></p> <ol style="list-style-type: none"> <li>For indoor units to which no MCU is connected, be sure to set Installation Option #2, Digit 3, to "2" (cooling only enabled) and connect the indoor units to a low-pressure gas pipe and a liquid pipe. Be sure to combine cooling only indoor units so that their total capacity becomes 50% or less of the total capacity of all indoor units.</li> <li>The following indoor units cannot be connected to one MCU port: Dedicated outdoor air system (4TVN00**A300N*), Convertible AHU (4TVM00**C100N*), AHU kit (4EEVAKA**K****).</li> </ol>		

# Electrical Wiring

Observe the following precautions when making electrical connections.

## WARNING

### **Hazardous Voltage!**

**Disconnect all electric power, including remote disconnects, before servicing. Follow proper lockout/tagout procedures to ensure that power can not be inadvertently energized. Failure to disconnect power before servicing could result in death or serious injury.**

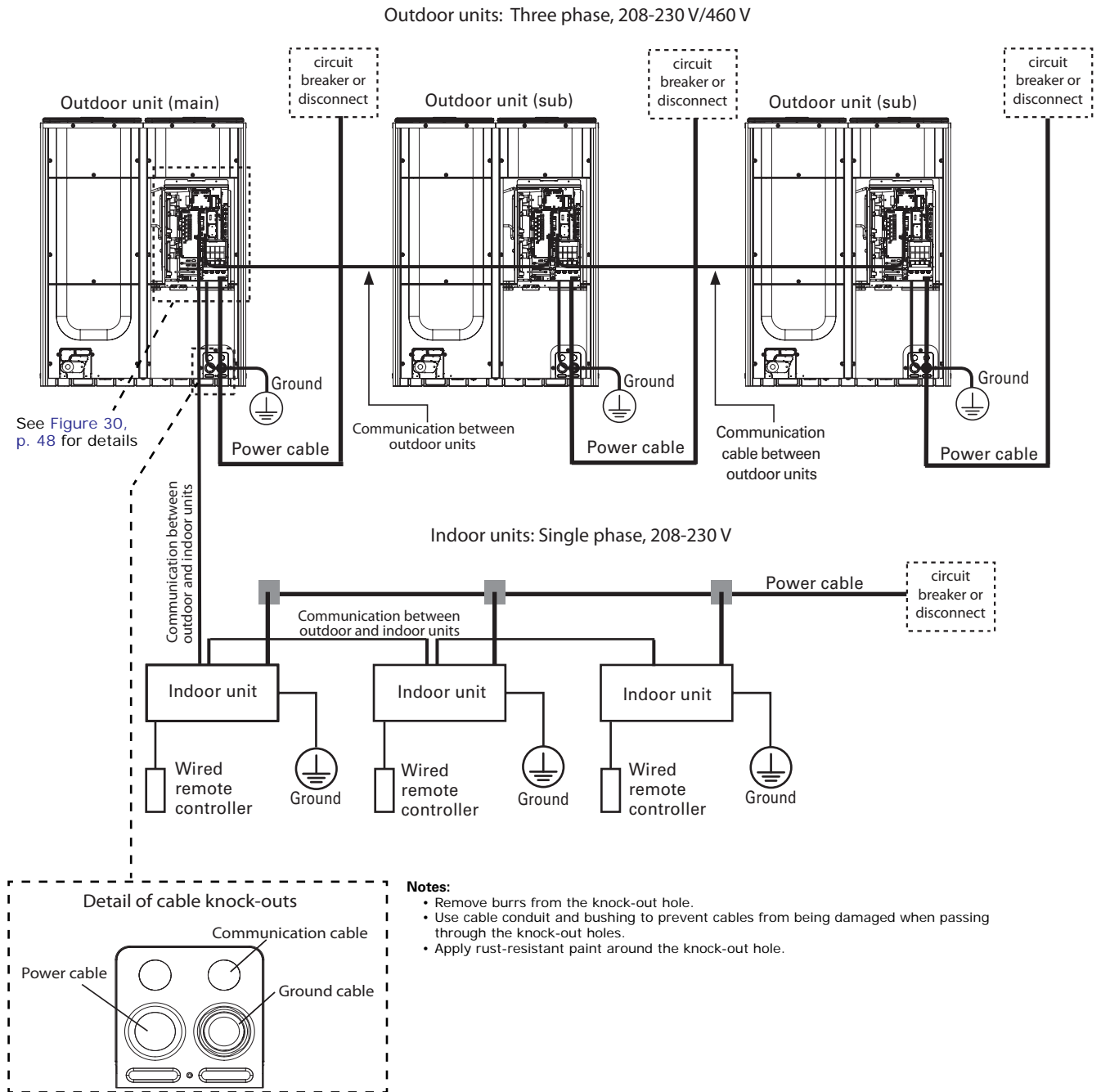
## NOTICE

### **Use Copper Conductors Only!**

**Unit terminals are not designed to accept other types of conductors. Failure to use copper conductors could result in equipment damage.**

- Make all electrical connections in accordance with electrical codes and ordinances.
- Multi-pole circuit breaker or disconnect is required to fully isolate the unit from all power.
- Install circuit breakers/disconnects in accordance with local and national codes.
- Select the power cable in accordance with relevant local and national regulations.
- Power cable specifications are based on the following conditions: underground/ambient temperature of 86°F (30°C), single multi-conductor cables.  
***Note:** If conditions are different from these, consult an electrical installation expert and re-select the power cable. If the length of power cable exceeds 164.04 ft, re-select the power cable considering the voltage drop.*
- Use a power cable made out of incombustible material for the insulator (inner cover) and the sheath (outer cover).
- All wiring must be protected from weather and damage.
- Do not use power cable that has exposed wire.
- Do not disconnect or change the factory wiring inside the unit.
- Provide strain relief for power and communication cables.
- Unbalanced power must be maintained within 10% of supply rating among all indoor units or the unit will stop and an error code will be generated. (Significantly unbalanced power may shorten the life of the system.)
- Maintain a distance of 2 in. or more between power and communication cables to prevent interference.

Figure 29. Typical system installation wiring



## Power Wiring

### ⚠ WARNING

#### Avoid Risk of Fire or Explosion!

Do not let the power cable come into contact with pipes inside the outdoor unit. If the power supply cable touches pipes, the vibrations of the compressor will be transferred to the pipes and can damage the power supply cables or pipes. The damage could result in fire or explosion, causing death or serious injury.

Follow this procedure:

1. Refer to [Table 30](#) and [Table 32, p. 50](#) for power cable and circuit breaker specifications. Refer to [Table 29, p. 47](#) for conduit specifications.
2. Cut the power cable to an appropriate length and connect it to the terminals in the power supply box with a solderless ring terminal (see [Figure 30, p. 48](#)).

**Table 28.**

Screw	Tightening torque for terminal	Power cable
M4	0.9–1.1 lbf/ft	Single-phase 208-230 V
M8	4.1–5.4 lbf/ft	Three-phase 208-230 V/460 V power cable

3. If two cables are connected to one terminal, place the cables back to back with the thin cable upward and the thick cable downward, as shown in the detail in [Figure 30](#).
4. Secure the cable(s) with a cable tie and provide strain relief.
5. Replace the cover on the terminal board.

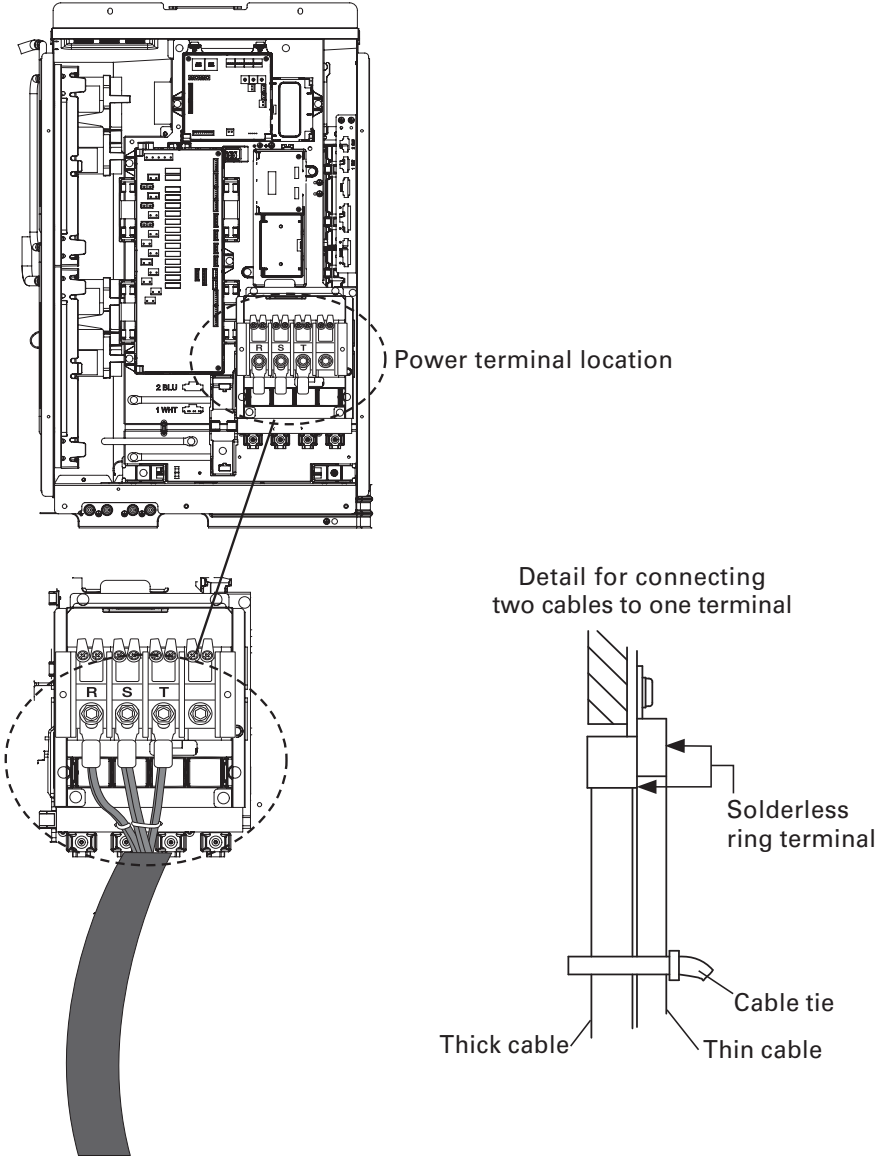
**Note:** Make sure that the section of the power supply cable that has the sheath removed is inside the power supply box. If this is not possible, connect the power cable conduit to the power supply box.

**Table 29. Cable conduit specifications**

Name	Temper grade	Application conditions
Flexible PVC conduit	PVC	If conduit is installed indoors and not exposed to outside elements (embedded in concrete)
Class 1 flexible conduit	Galvanized steel sheet	If conduit is installed indoors but exposed to outside elements
Class 1 PVC-coated flexible conduit	Galvanized steel sheet and soft PVC compound	If conduit is installed outdoors and requires waterproofing

6. Pull the power cable through the designated knock-out at the bottom right of the outdoor unit (see [Figure 29, p. 46](#) for details).

Figure 30. Power wiring terminal connections





**Table 30. Circuit breaker and power cable specifications—Heat pump/heat recovery: 208–230 V**

Capacity (tons)	Model	Units		Module 1									Module 2									Module 3								
				RLA			FLA			Power supply			RLA			FLA			Power supply			RLA			FLA			Power supply		
		Hz	V	Com1	Com2	Fan1	Fan2	MCA (A)	MOP (A)	SCCR (kA)	Com1	Com2	Fan1	Fan2	MCA (A)	MOP (A)	SCCR (kA)	Com1	Com2	Fan1	Fan2	MCA (A)	MOP (A)	SCCR (kA)						
6	4TV*0072*300N*	60	208/230	14.3	—	4.0	—	28.0	35	5	—	—	—	—	—	—	—	—	—	—	—	—	—							
8	4TV*0096*300N*	60	208/230	13.9	13.9	3.0	3.0	37.8	50	5	—	—	—	—	—	—	—	—	—	—	—	—	—							
10	4TV*0120*300N*	60	208/230	14.8	14.8	3.0	3.0	43.0	50	5	—	—	—	—	—	—	—	—	—	—	—	—	—							
12	4TV*0144*300N*	60	208/230	20.7	20.7	3.0	3.0	52.6	70	5	—	—	—	—	—	—	—	—	—	—	—	—	—							
14	4TV*0168*300N*	60	208/230	24.0	24.0	3.0	3.0	66.0	80	5	—	—	—	—	—	—	—	—	—	—	—	—	—							
16	4TV*0192*300N*	60	208/230	28.0	28.0	3.0	3.0	73.0	90	5	—	—	—	—	—	—	—	—	—	—	—	—	—							
18	4TV*0216*300N*	60	208/230	14.3	—	4.0	—	28.0	35	5	20.7	20.7	3.0	3.0	52.6	70	5	—	—	—	—	—	—							
20	4TV*0240*300N*	60	208/230	14.3	—	4.0	—	28.0	35	5	24.0	24.0	3.0	3.0	66.0	80	5	—	—	—	—	—	—							
22	4TV*0264*300N*	60	208/230	14.3	—	4.0	—	28.0	35	5	28.0	28.0	3.0	3.0	73.0	90	5	—	—	—	—	—	—							
24	4TV*0288*300N*	60	208/230	20.7	20.7	3.0	3.0	52.6	70	5	20.7	20.7	3.0	3.0	52.6	70	5	—	—	—	—	—	—							
26	4TV*0312*300N*	60	208/230	20.7	20.7	3.0	3.0	52.6	70	5	24.0	24.0	3.0	3.0	66.0	80	5	—	—	—	—	—	—							
28	4TV*0336*300N*	60	208/230	24.0	24.0	3.0	3.0	66.0	80	5	24.0	24.0	3.0	3.0	66.0	80	5	—	—	—	—	—	—							
30	4TV*0360*300N*	60	208/230	24.0	24.0	3.0	3.0	66.0	80	5	28.0	28.0	3.0	3.0	73.0	90	5	—	—	—	—	—	—							
32	4TV*0384*300N*	60	208/230	28.0	28.0	3.0	3.0	73.0	90	5	28.0	28.0	3.0	3.0	73.0	90	5	—	—	—	—	—	—							
34	4TV*0408*300N*	60	208/230	14.3	—	4.0	—	28.0	35	5	20.7	20.7	3.0	3.0	52.6	70	5	28.0	28.0	3.0	3.0	73.0	90	5						
36	4TV*0432*300N*	60	208/230	20.7	20.7	3.0	3.0	52.6	70	5	20.7	20.7	3.0	3.0	52.6	70	5	20.7	20.7	3.0	3.0	52.6	70	5						
38	4TV*0456*300N*	60	208/230	14.8	14.8	3.0	3.0	43.0	50	5	24.0	24.0	3.0	3.0	66.0	80	5	24.0	24.0	3.0	3.0	66.0	80	5						
40	4TV*0480*300N*	60	208/230	20.7	20.7	3.0	3.0	52.6	70	5	24.0	24.0	3.0	3.0	66.0	80	5	24.0	24.0	3.0	3.0	66.0	80	5						
42	4TV*0504*300N*	60	208/230	24.0	24.0	3.0	3.0	66.0	80	5	24.0	24.0	3.0	3.0	66.0	80	5	24.0	24.0	3.0	3.0	66.0	80	5						
44	4TV*0528*300N*	60	208/230	24.0	24.0	3.0	3.0	66.0	80	5	24.0	24.0	3.0	3.0	66.0	80	5	28.0	28.0	3.0	3.0	73.0	90	5						

**Notes:**

- RLA is based on AHRI 1230 cooling standard condition (indoor temp: 80°F (26.7°C) DB/67°F (19.46°C) WB; outdoor temp: 95°F (35°C) DB.
- Voltage tolerance is ±10%.
- Maximum allowable voltage between phases is 2%.
- Refer to module combination table for independent units information.
- Abbreviations: RLA: Rated load ampere; FLA: Full load ampere; MCA: Minimum circuit amperes ; MOP: Maximum overcurrent protective device (amperes), SCCR: Short circuit current rating.

**Table 31. Circuit breaker and power cable specifications—Low ambient heat pump/heat recovery: 208–230 V**

Capacity (tons)	Model	Units		Module 1									Module 2									Module 3								
				RLA			FLA			Power supply			RLA			FLA			Power supply			RLA			FLA			Power supply		
		Hz	V	Com1	Com2	Fan1	Fan2	MCA (A)	MOP (A)	SCCR (kA)	Com1	Com2	Fan1	Fan2	MCA (A)	MOP (A)	SCCR (kA)	Com1	Com2	Fan1	Fan2	MCA (A)	MOP (A)	SCCR (kA)						
6	4TV*L072*300N*	60	208/230	19.5	19.5	3.0	3.0	50.0	60.0	5																				
8	4TV*L096*300N*	60	208/230	28.4	28.4	3.0	3.0	70.0	80.0	5																				
12	4TV*L144*300N*	60	208/230	19.5	19.5	3.0	3.0	50.0	60.0	5	19.5	19.5	3.0	3.0	50.0	60.0	5													
14	4TV*L168*300N*	60	208/230	19.5	19.5	3.0	3.0	50.0	60.0	5	28.4	28.4	3.0	3.0	70.0	80.0	5													
16	4TV*L192*300N*	60	208/230	28.4	28.4	3.0	3.0	70.0	80.0	5	28.4	28.4	3.0	3.0	70.0	80.0	5													
18	4TV*L216*300N*	60	208/230	19.5	19.5	3.0	3.0	50.0	60.0	5	19.5	19.5	3.0	3.0	50.0	60.0	5	19.5	19.5	3.0	3.0	50.0	60.0	5						
20	4TV*L240*300N*	60	208/230	19.5	19.5	3.0	3.0	50.0	60.0	5	19.5	19.5	3.0	3.0	50.0	60.0	5	28.4	28.4	3.0	3.0	70.0	80.0	5						
22	4TV*L264*300N*	60	208/230	19.5	19.5	3.0	3.0	50.0	60.0	5	28.4	28.4	3.0	3.0	70.0	80.0	5	28.4	28.4	3.0	3.0	70.0	80.0	5						
24	4TV*L288*300N*	60	208/230	28.4	28.4	3.0	3.0	70.0	80.0	5	28.4	28.4	3.0	3.0	70.0	80.0	5	28.4	28.4	3.0	3.0	70.0	80.0	5						

**Notes:**

- RLA is based on AHRI 1230 cooling standard condition (indoor temp: 80°F (26.7°C) DB/67°F (19.46°C) WB; outdoor temp: 95°F (35°C) DB.
- Voltage tolerance is ±10%.
- Maximum allowable voltage between phases is 2%.
- Refer to module combination table for independent units information.
- Abbreviations: RLA: Rated load ampere; FLA: Full load ampere; MCA: Minimum circuit amperes ; MOP: Maximum overcurrent protective device (amperes), SCCR: Short circuit current rating.

## Electrical Wiring

**Table 32. Circuit breaker and power cable specifications—Heat pump/heat recovery: 460 V**

Capacity (tons)	Model	Units		Module 1									Module 2						Module 3					
				RLA		FLA		Power supply			RLA		FLA		Power supply			RLA		FLA		Power supply		
		Hz	V	Comp1	Comp2	Fan1	Fan2	MCA (A)	MOP (A)	SCCR (kA)	Comp1	Comp2	Fan1	Fan2	MCA (A)	MOP (A)	SCCR (kA)	Comp1	Comp2	Fan1	Fan2	MCA (A)	MOP (A)	SCCR (kA)
6	4TV*0072*400N*	60	460	9.5	—	2.0	—	16.4	20	5	—	—	—	—	—	—	—	—	—	—	—	—	—	—
8	4TV*0096*400N*	60	460	11.5	—	1.5	1.5	19.0	25	5	—	—	—	—	—	—	—	—	—	—	—	—	—	—
10	4TV*0120*400N*	60	460	14.0	—	1.5	1.5	21.7	30	5	—	—	—	—	—	—	—	—	—	—	—	—	—	—
12	4TV*0144*400N*	60	460	11.4	11.4	1.5	1.5	28.7	40	5	—	—	—	—	—	—	—	—	—	—	—	—	—	—
14	4TV*0168*400N*	60	460	12.0	12.0	1.5	1.5	33.0	40	5	—	—	—	—	—	—	—	—	—	—	—	—	—	—
16	4TV*0192*400N*	60	460	14.5	14.5	1.5	1.5	37.0	50	5	—	—	—	—	—	—	—	—	—	—	—	—	—	—
18	4TV*0216*400N*	60	460	9.5	—	2.0	—	16.4	20	5	11.4	11.4	1.5	1.5	28.7	40	5	—	—	—	—	—	—	—
20	4TV*0240*400N*	60	460	9.5	—	2.0	—	16.4	20	5	12.0	12.0	1.5	1.5	33.0	40	5	—	—	—	—	—	—	—
22	4TV*0264*400N*	60	460	9.5	—	2.0	—	16.4	20	5	14.5	14.5	1.5	1.5	37.0	50	5	—	—	—	—	—	—	—
24	4TV*0288*400N*	60	460	11.4	11.4	1.5	1.5	28.7	40	5	11.4	11.4	1.5	1.5	28.7	40	5	—	—	—	—	—	—	—
26	4TV*0312*400N*	60	460	11.4	11.4	1.5	1.5	28.7	40	5	12.0	12.0	1.5	1.5	33.0	40	5	—	—	—	—	—	—	—
28	4TV*0336*400N*	60	460	12.0	12.0	1.5	1.5	33.0	40	5	12.0	12.0	1.5	1.5	33.0	40	5	—	—	—	—	—	—	—
30	4TV*0360*400N*	60	460	12.0	12.0	1.5	1.5	33.0	40	5	14.5	14.5	1.5	1.5	37.0	50	5	—	—	—	—	—	—	—
32	4TV*0384*400N*	60	460	14.5	14.5	1.5	1.5	37.0	50	5	14.5	14.5	1.5	1.5	37.0	50	5	—	—	—	—	—	—	—
34	4TV*0408*400N*	60	460	9.5	—	2.0	—	16.4	20	5	11.4	11.4	1.5	1.5	28.7	40	5	14.5	14.5	1.5	1.5	37.0	50	5
36	4TV*0432*400N*	60	460	11.4	11.4	1.5	1.5	28.7	40	5	11.4	11.4	1.5	1.5	28.7	40	5	11.4	11.4	1.5	1.5	28.7	40	5
38	4TV*0456*400N*	60	460	14.0	—	1.5	1.5	21.7	30	5	12.0	12.0	1.5	1.5	33.0	40	5	12.0	12.0	1.5	1.5	33.0	40	5
40	4TV*0480*400N*	60	460	11.4	11.4	1.5	1.5	28.7	40	5	12.0	12.0	1.5	1.5	33.0	40	5	12.0	12.0	1.5	1.5	33.0	40	5
42	4TV*0504*400N*	60	460	12.0	12.0	1.5	1.5	33.0	40	5	12.0	12.0	1.5	1.5	33.0	40	5	12.0	12.0	1.5	1.5	33.0	40	5
44	4TV*0528*400N*	60	460	12.0	12.0	1.5	1.5	33.0	40	5	12.0	12.0	1.5	1.5	33.0	40	5	14.5	14.5	1.5	1.5	37.0	50	5

**Notes:**

- RLA is based on AHRI 1230 cooling standard condition (indoor temp: 80°F (26.7°C) DB/67°F (19.46°C) WB; outdoor temp: 95°F (35°C) DB.
- Voltage tolerance is ± 10%.
- Maximum allowable voltage between phases is 2%.
- Refer to module combination table for independent units information.
- Abbreviations: RLA: Rated load ampere; FLA: Full load ampere; MCA: Minimum circuit amperes ; MOP: Maximum overcurrent protective device (amperes), SCCR: Short circuit current rating.

**Table 33. Circuit breaker and power cable specifications—Low ambient heat pump/heat recovery: 460 V**

Capacity (tons)	Model	Units		Module 1									Module 2						Module 3					
				RLA		FLA		Power supply			RLA		FLA		Power supply			RLA		FLA		Power supply		
		Hz	V	Com1	Com2	Fan1	Fan2	MCA (A)	MOP (A)	SCCR (kA)	Com1	Com2	Fan1	Fan2	MCA (A)	MOP (A)	SCCR (kA)	Com1	Com2	Fan1	Fan2	MCA (A)	MOP (A)	SCCR (kA)
6	4TV*L072*400N*	60	460	11.1	11.1	1.5	1.5	28.0	35.0	5														
8	4TV*L096*400N*	60	460	15.5	15.5	1.5	1.5	38.0	45.0	5														
12	4TV*L144*400N*	60	460	11.1	11.1	1.5	1.5	28.0	35.0	5	11.1	11.1	1.5	1.5	28.0	35.0	5							
14	4TV*L168*400N*	60	460	11.1	11.1	1.5	1.5	28.0	35.0	5	15.5	15.5	1.5	1.5	38.0	45.0	5							
16	4TV*L192*400N*	60	460	15.5	15.5	1.5	1.5	38.0	45.0	5	15.5	15.5	1.5	1.5	38.0	45.0	5							
18	4TV*L216*400N*	60	460	11.1	11.1	1.5	1.5	28.0	35.0	5	11.1	11.1	1.5	1.5	28.0	35.0	5	11.1	11.1	1.5	1.5	28.0	35.0	5
20	4TV*L240*400N*	60	460	11.1	11.1	1.5	1.5	28.0	35.0	5	11.1	11.1	1.5	1.5	28.0	35.0	5	15.5	15.5	1.5	1.5	38.0	45.0	5
22	4TV*L264*400N*	60	460	11.1	11.1	1.5	1.5	28.0	35.0	5	15.5	15.5	1.5	1.5	38.0	45.0	5	15.5	15.5	1.5	1.5	38.0	45.0	5
24	4TV*L288*400N*	60	460	15.5	15.5	1.5	1.5	38.0	45.0	5	15.5	15.5	1.5	1.5	38.0	45.0	5	15.5	15.5	1.5	1.5	38.0	45.0	5

**Notes:**

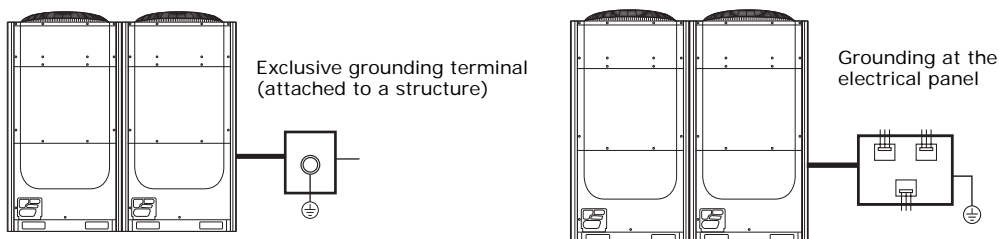
- RLA is based on AHRI 1230 cooling standard condition (indoor temp: 80°F (26.7°C) DB/67°F (19.46°C) WB; outdoor temp: 95°F (35°C) DB.
- Voltage tolerance is ± 10%.
- Maximum allowable voltage between phases is 2%.
- Refer to module combination table for independent units information.
- Abbreviations: RLA: Rated load ampere; FLA: Full load ampere; MCA: Minimum circuit amperes ; MOP: Maximum overcurrent protective device (amperes), SCCR: Short circuit current rating.

## Grounding

**Important:** Grounding must be done by a qualified electrician.

Refer to outdoor unit grounding examples (Figure 31) and to grounding resistance requirements (Table 34).

**Figure 31. Outdoor unit grounding examples**

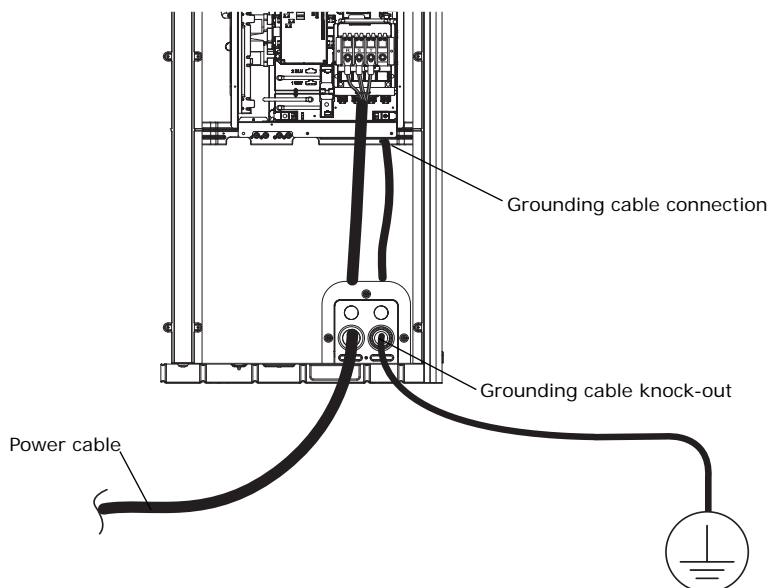


**Table 34. Grounding resistance requirements**

Power condition at installation site	High or average humidity	Low humidity
Voltage to ground is $\leq 150$ V	<ul style="list-style-type: none"> <li>Ensure that the grounding resistance is <math>&lt; 100 \Omega</math>.</li> <li>If a circuit breaker is installed that disconnects the circuit within 0.5 seconds, the allowable grounding resistance is <math>30\text{--}500 \Omega</math>.</li> </ul>	<ul style="list-style-type: none"> <li>Ideally, grounding resistance should be <math>&lt; 100 \Omega</math> and should not exceed <math>250 \Omega</math>.</li> </ul>
Voltage to ground is $> 150$ V		<ul style="list-style-type: none"> <li>Ensure that the grounding resistance is <math>&lt; 100 \Omega</math>.</li> <li>If a circuit breaker is installed that disconnects the circuit within 0.5 seconds, the allowable grounding resistance is <math>30\text{--}500 \Omega</math>.</li> </ul>

1. Select rated grounding cable by referring to the outdoor unit power cable specifications (Table 30, p. 49 and Table 32, p. 50).
2. Connect the grounding cable to the grounding hole inside the power supply box and pull it through the designated grounding knock-out (see Figure 32 for details).

**Figure 32. Grounding cable connection location**



### Communications Wiring

Use 18 AWG, 25 pF/ft nom., 60.7  $\Omega$  impedance, braid or foil shielded, twisted pair wire for communications wiring.

Refer to [Table 29, p. 47](#) for conduit specifications.

#### **⚠ WARNING**

##### **Hazardous Voltage!**

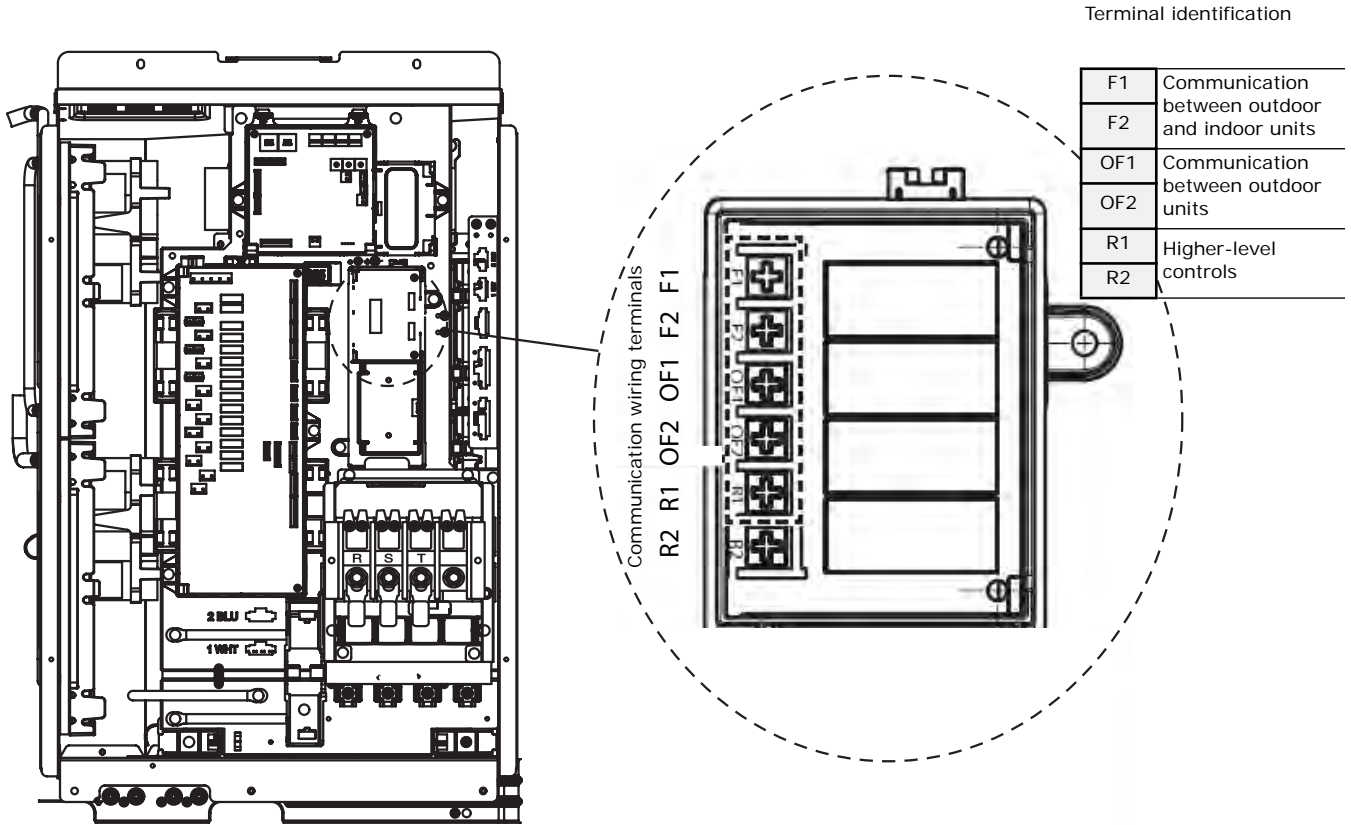
**Disconnect all electric power, including remote disconnects before servicing. Follow proper lockout/tagout procedures to ensure the power can not be inadvertently energized. Failure to disconnect power before servicing could result in death or serious injury.**

1. Connect the communications wiring as shown in [Figure 33](#).

**Notes:**

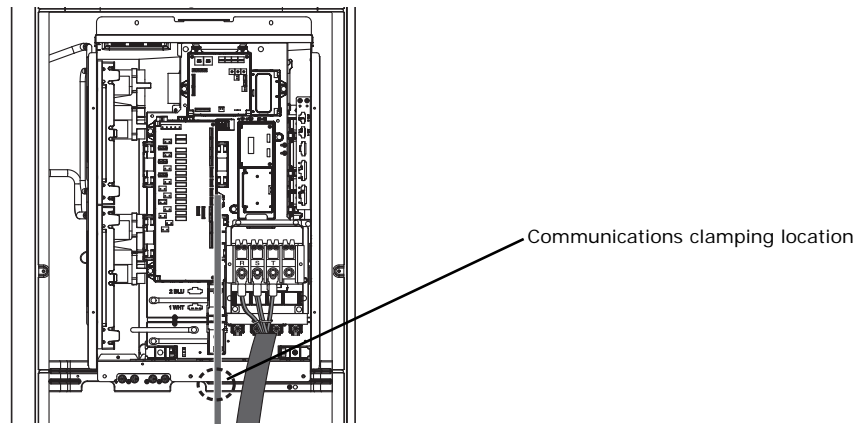
- *Ensure that more than 1 in. of the outer sheath of the power and communication cable conduit are inside the electrical component box.*
- *To reduce interference, ensure that power and communication cables run in parallel or, if crossing is necessary, cross at 90 degrees.*
- The communication cable between outdoor units and between indoor and outdoor units has no polarity.

**Figure 33. Communications board and wiring terminals**



2. To provide strain relief, secure the communications cable with a clamp in the location shown in [Figure 34](#).

**Figure 34. Communications cable clamping location**



3. Pull the communications cable through the designated knock-out at the bottom right of the outdoor unit (see [Figure 29, p. 46](#) for details).

# Leak Testing Pipe Connections

Before leak testing pipe connections, read all safety precautions and notes.

## **⚠ WARNING**

### **Confined Space Hazards!**

Do not work in confined spaces where refrigerant or other hazardous, toxic or flammable gas may be leaking. Refrigerant or other gases could displace oxygen, causing possible asphyxiation or other serious health risks. Some gases may be flammable and/or explosive. If a leak in such spaces is detected, evacuate the area immediately and contact the proper rescue or response authority. Failure to take appropriate precautions or to react properly to such potential hazards could result in death or serious injury.

## **⚠ WARNING**

### **Explosion Hazard!**

Never use an open flame to detect gas leaks. It could result in an explosion. Use a leak test solution for leak testing. Failure to follow recommended safe leak test procedures could result in death or serious injury or equipment or property-only-damage.

Use only dry nitrogen with a pressure regulator for pressurizing unit. Do not use acetylene, oxygen or compressed air or mixtures containing them for pressure testing. Do not use mixtures of a hydrogen containing refrigerant and air above atmospheric pressure for pressure testing as they may become flammable and could result in an explosion. Refrigerant, when used as a trace gas should only be mixed with dry nitrogen for pressurizing units. Failure to follow these recommendations could result in death or serious injury or equipment or property-only damage.

Do not exceed unit nameplate design pressures when leak testing system. Failure to follow these instructions could result in an explosion causing death or serious injury.

## **NOTICE**

### **Refrigerant Pipe Damage!**

When performing a leak test, use a pressure regulator to prevent an excess amount of nitrogen (over 594.6 psi) from entering the pipes. If the pipe is filled with over the specified amount of nitrogen in a short time, pipes may be damaged.

- All required pipe leak testing must be completed in accordance with national and/or local codes.
- Use R-410A refrigerant gas as a tracer for leak detection.
- Use oil-pumped dry nitrogen to develop required test pressures.
- Use tools rated for R-410A refrigerant.
- Perform the leak test with the outdoor unit service valves closed.
- Do not remove the Schrader core from the service valves.
- Leak test only one circuit at a time to minimize system exposure to potentially harmful moisture in the air.

To perform the test:

1. Connect the refrigerant manifold gauge hoses to the liquid side and gas side service ports on the unit, and connect the center hose to a nitrogen gas tank fitted with a pressure regulator (see [Figure 35, p. 55](#) and [Figure 36, p. 56](#)).
2. Fill the lines with nitrogen as described:
  - a. To 72 psi for 5 minutes.
  - b. Then, to 220 psi for 5 minutes.

- c. Then, to 590 psi for 24 hours.
3. If the pressure drops for any reason other than verifiable temperature fluctuations, check for leaks and repair them. Use soapy water to check for leaks; bubbles will form if joints are not tight.
4. Release pressure in pipelines gradually.
5. Repair leaks.
6. Repeat the previous steps until the pressure remains constant at 145 psi for at least 15 minutes.
7. When testing is finished, remove hoses from service ports.

**Figure 35. Leak testing pipe connections: Heat pump**

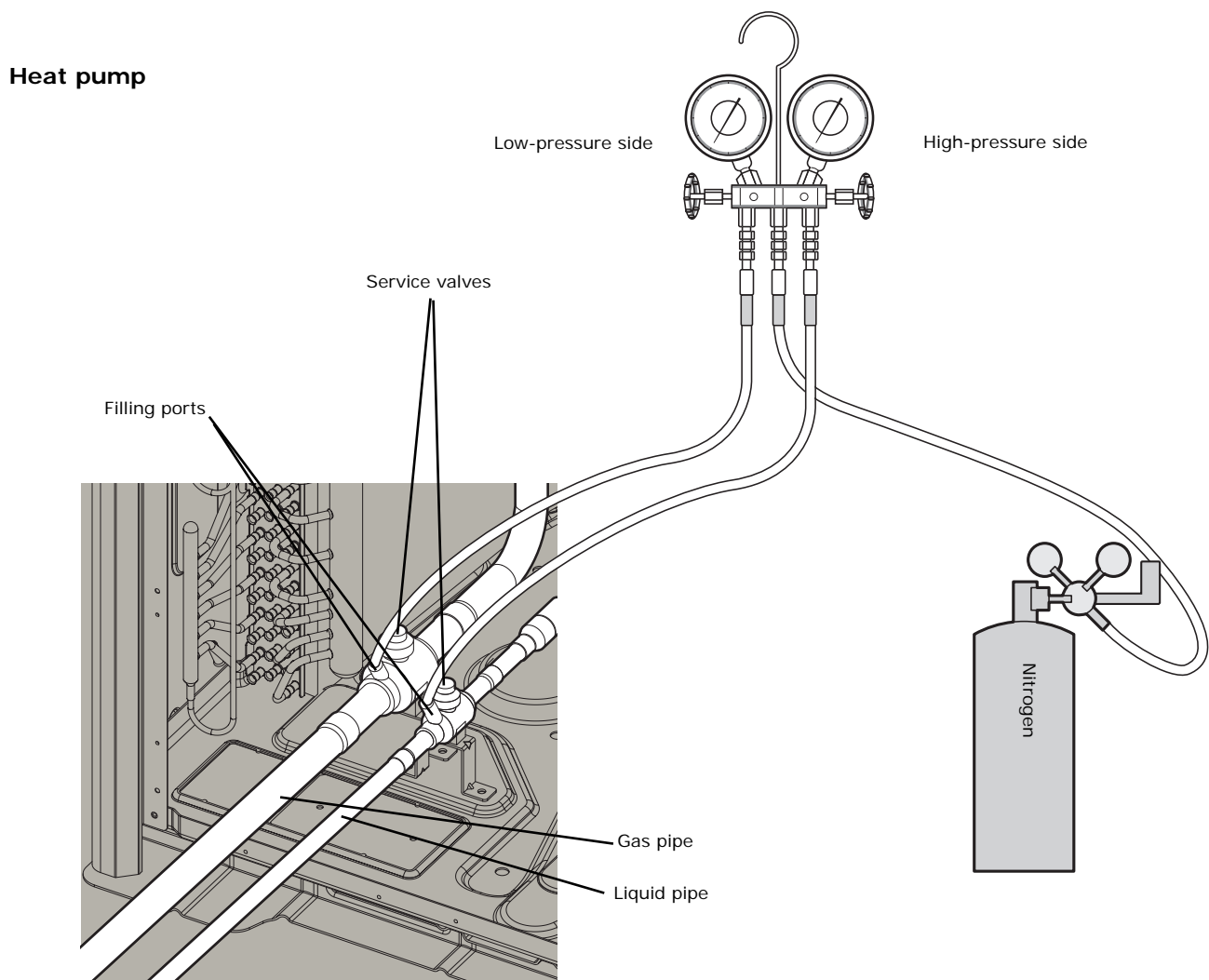
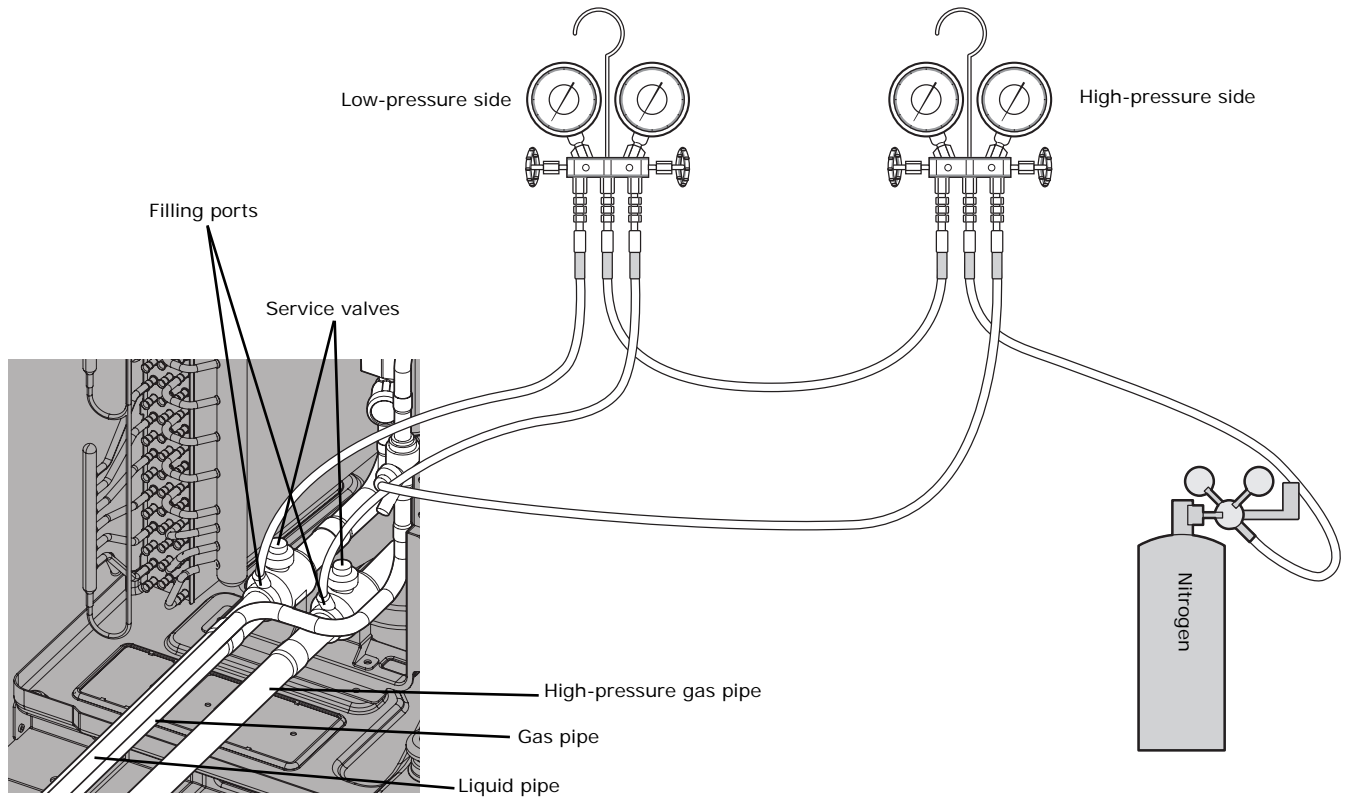


Figure 36. Leak testing pipe connections: Heat recovery

## Heat recovery



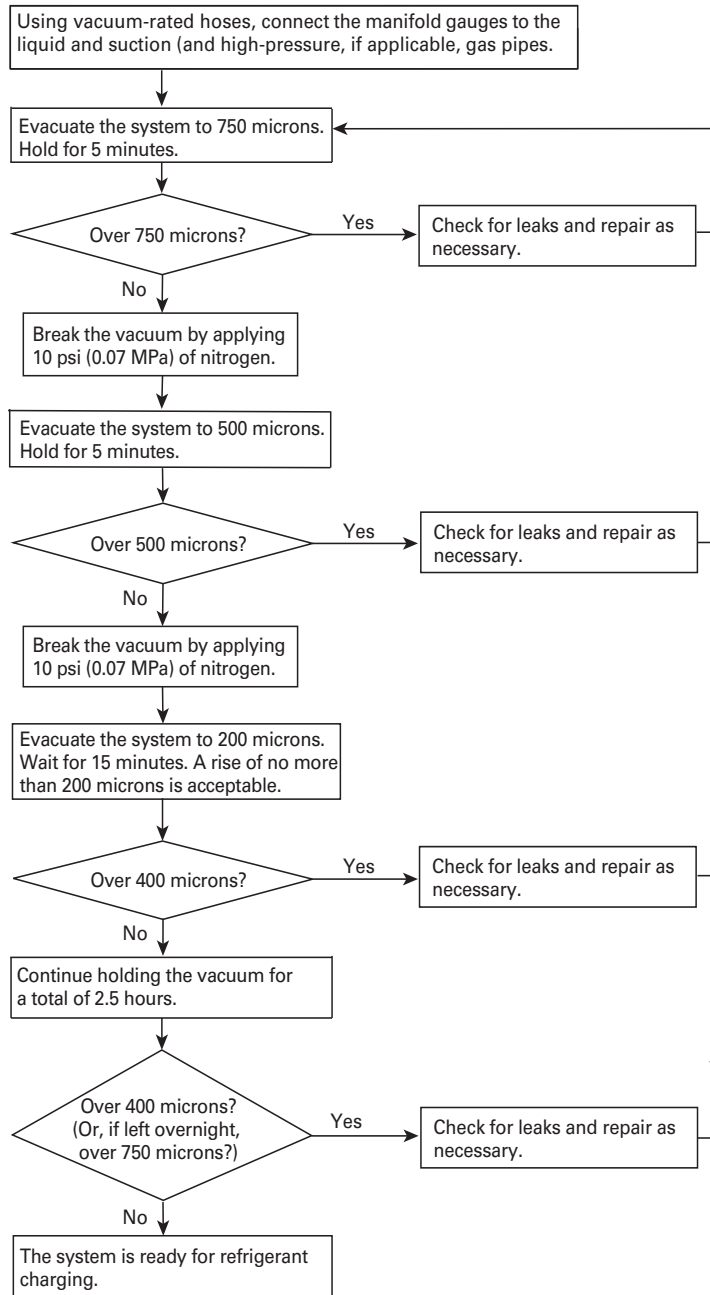


# Vacuum Drying

After performing a leak test, use a vacuum pump to triple evacuate the system as described below:

**Notes:**

- Use a vacuum pump with a check valve to prevent pump oil from flowing backward while the vacuum pump is closed.
- Completely close the liquid-gas side service valve of the outdoor unit.



# Insulating Refrigerant Pipes

After determining that there are no leaks in the refrigerant pipes, insulate them as described:

1. Use [Table 35](#) to select the insulation thickness according to pipe size and humidity conditions.

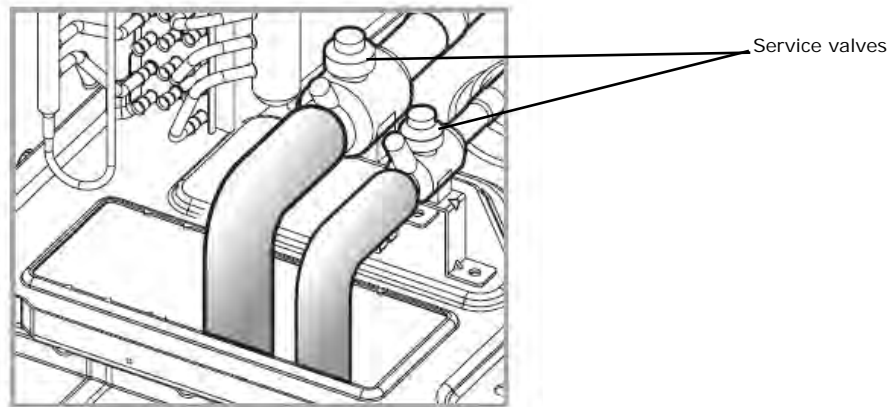
**Table 35. Pipe insulation selector**

Pipe	Pipe size in.	Insulation, EPDM or NBR (in.)	
		Standard conditions 86°F (30°C) < 85%	High humidity conditions <sup>(a)</sup> 86°F (30°C) ≥ 85%
Liquid pipe	1/4 – 3/8	3/8	3/8
	1/2 – 2	1/2	1/2
Gas pipe <sup>(b)</sup>	1/4	1/2	3/4
	3/8 – 1	3/4	1.0
	1-1/8 – 1-3/4		1-1/4
	2	1.0	1-1/2

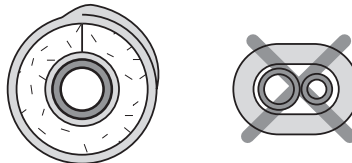
(a) When installing insulation in any of the following environments, use insulation required for high humidity conditions: Buildings with close proximity to bodies of water or hot springs or on the side of a hill in which the building is partly covered by earth; ceilings frequently exposed to moisture such as in restaurants, saunas, swimming pools, and corridors of dormitories or studios near a frequently-used outdoor exit; buildings with no ventilation system.  
 (b) Internal temperature of gas pipe is higher than 248°F (120°C).

2. Wrap insulation around the entire surface of each pipe, including the refrigerant pipes from the indoor unit to the service valves inside the outdoor unit, the Y-joints, distribution header, and connection points on each pipe.

**Note:** For details on insulating Y-joints and distribution headers, refer to the branch joint installation manual (VRF-SVN41).



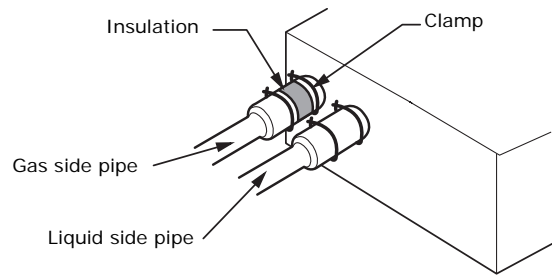
- Do not wrap the gas and liquid refrigerant pipes together.



- Overlap insulation to avoid gaps.
- Avoid compressing the insulation as much as possible.
- Be sure there are no cracks or deformities in the insulation at bends in pipes.

- If necessary double the insulation to prevent condensation from forming in warm or humid areas.

3. Clamp insulation tightly to the pipes.



4. Cut off excess insulation.

# Refrigerant

After successful leak testing and vacuum drying, charge the system with refrigerant as explained in this section.

## Calculating the Refrigerant

The initial refrigerant quantity (given in [Table 36](#)) is charged into the unit at the factory.

Calculate the total amount of additional refrigerant using [Table 37](#) through [Table 39](#), p. 61.

**Table 36. Initial refrigerant quantity for each outdoor unit model**

Model	4TV*0072	4TV*0096	4TV*0120	4TV*0144	4TV*0168	4TV*0192	4TV*L072	4TV*L096
<b>Initial refrigerant quantity: lb</b>	12.1	16.3	16.3	19.2	24.3	24.3	19.2	24.3
<b>Note:</b> Add the initial refrigerant quantity shown in this table to the refrigerant calculated in <a href="#">Table 37</a> through <a href="#">Table 39</a> , p. 61.								

**Table 37. Refrigerant quantity according to liquid pipe diameter and length (a)**

Diameter of liquid pipe: in.	1/4	3/8	1/2 (12.7)	5/8	3/4	7/8 (22.23)	1
<b>Additional refrigerant quantity: lb/ft</b>	0.013	0.040	0.084	0.121	0.181	0.235	0.356

**Note:** For an indoor unit with a factory-installed EEV, the quantity of refrigerant in addition to the quantity based on the unit capacity ([Table 36](#)) is 0.0067 lb/ft regardless of the pipe size.

**Table 38. Refrigerant quantity for each indoor unit (b)**

Model	Capacity (MBH)																		
	5/6	7/7.5	9/9.5	12	15	18	20	24	27	30	36	42	48	54	60	72	76.8	96	
	<b>Refrigerant quantity: lb</b>																		
1-way cassette (4TVE00**B100N*)		0.55	0.55	0.55															
Mini 4-way cassette (4TVB00**B100N*)	0.64	0.64	0.64	0.64		0.82	0.82												
4-way cassette (4TVC00**B100N*)			0.99	0.99		0.99		0.99		1.52	1.52		1.52						
Circular cassette (4TVS00**B100N*)			0.99	0.99		0.99		0.99		1.52	1.52		1.52						
Slim duct (optional condensate pump) (4TVL00**B100N*)		0.77	0.77	0.77		0.99		0.99		0.93	0.93		1.37						
MSP duct (standard condensate pump) (4TVD00**C100N*)		0.82	0.82	0.82	0.82	1.19		1.04	1.04	1.04	1.50		1.50	2.01					
MSP duct (optional condensate pump) (4TVD00**B100N*)						0.62		0.62		1.19	1.19		1.50						
HSP duct (optional condensate pump) (4TVA00**B100N*)											1.50		1.50					2.60	2.60
High-wall with EEV (4TVW00**B100N*)		0.75	0.75	0.75		1.12	1.12	1.12											
Convertible ceiling/floor (4TVX00**B100NB)						0.86		0.86											

**Table 38. Refrigerant quantity for each indoor unit (b) (continued)**

Model	Capacity (MBH)																	
	5/6	7/7.5	9/9.5	12	15	18	20	24	27	30	36	42	48	54	60	72	76.8	96
	<b>Refrigerant quantity: lb</b>																	
Floor standing unit (4TVF00**B100N*)	0.26		0.49	0.49		0.71		0.71										
Convertible AHU (4TVM00**B100N*)			0.73	0.73		1.1												
Dedicated outside air system (4TVN00**B300N*)																2.60		2.60

**Notes:**

- Additional refrigerant charging of MCU is 1.1 lb for every MCU kit.
- For an indoor unit with an AHU kit, add 0.04 lb of refrigerant for 1 MBH capacity of the AHU kit.

**Table 39. Calculation example for refrigerant amount additional to basic unit amount**

Liquid pipe (a) diameter in.	Pipe length (ft)	Refrigerant amount (lb/ft) from Table 37, p. 60	Additional refrigerant amount (lb)	Total additional refrigerant (lb)
	(1)	(2)	(1) x (2)	∑ (1) x (2)
1/4	114.8	0.013	1.49	12.19
3/8	164.0	0.040	6.56	
1/2	49.2	0.084	4.13	

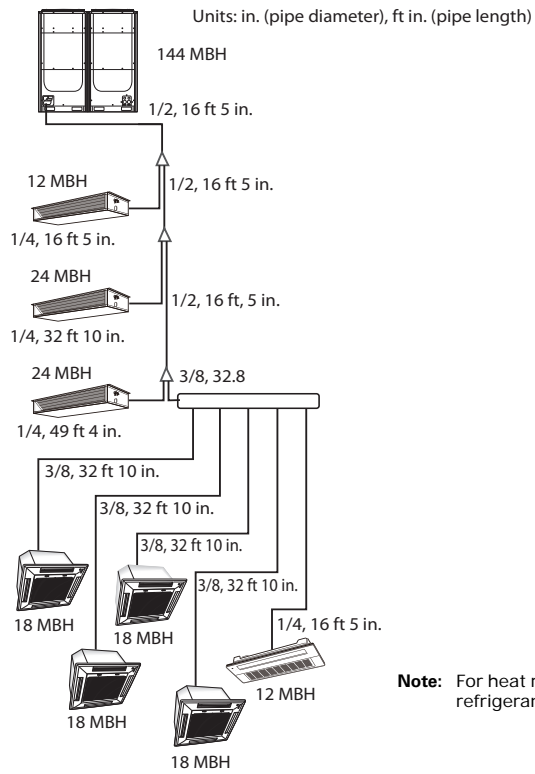
Indoor unit (b) model	Number of units	Refrigerant amount (lb/each) from Table 38, p. 60	Additional refrigerant amount (lb)	Total additional refrigerant (lb)
	(1)	(2)	(1) x (2)	∑ (1) x (2)
4-way cassette (4TVC0018B100N*)	4	0.99	3.96	7.02
Slim duct (4TVL0012B100N*)	1	0.53	0.53	
Slim duct (4TVL0024B100N*)	2	0.99	1.98	
1-way cassette (4TVE00B100N*)	1	0.55	0.55	

**Notes:**

- The total amount of refrigerant in the system must not exceed 220 lb. If the refrigerant weight exceeds this amount, separate the modules into smaller modules (or units) so that the maximum weight is not exceeded. For example, for 4TV\*144\*\*\*\*\*, the basic amount of refrigerant is 19.2 lb. Therefore, the total amount of additional refrigerant (a) + (b) should not exceed 200.8 lb.
- For each MCU kit, additional refrigerant charging is 1.1 lb.
- For an indoor unit with an AHU kit, add 0.04 lb of refrigerant for 1 MBH capacity of the AHU kit.

# Refrigerant

## Example:



**Note:** For heat recovery systems, add 1.1 lb additional refrigerant for each MCU kit.

## Charging Refrigerant

After calculating the correct amount of refrigerant needed by the system (see “Calculating the Refrigerant” p. 60), charge the system as described in the following procedure and in Figure 37:

### ⚠ WARNING

#### Hazard of Explosion and Deadly Gases!

Do not heat the refrigerant container to speed up the charging process. An explosion could occur, resulting in death or serious injury.

### NOTICE

#### Risk of Unit Malfunction!

Do not leave the front panel open while charging refrigerant. If the front panel is open, the amount charged into the unit will be incorrect.

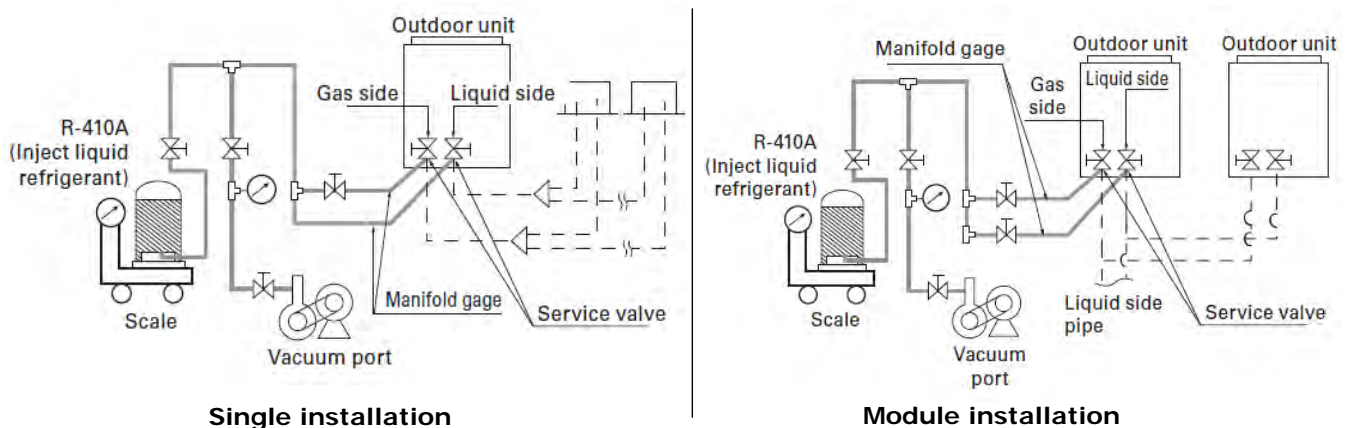
### NOTICE

#### Unit Component Damage!

Open the gas side and liquid side service valves completely after charging the refrigerant. If you operate the unit with the service valves closed, the unit may be damaged.

1. Attach the liquid manifold hose to the liquid side service port and open the manifold gauge valve.
2. Add the liquid refrigerant, making sure the refrigerant bottle is held in an upright position. Use a scale to determine that the correct amount has been added.
3. Close the refrigerant container immediately after adding the refrigerant.
4. If you are unable to add all of the refrigerant needed into the liquid side, close the liquid side service port and remove the liquid manifold hose.
5. Attach the gas manifold hose to the gas side service port and open the manifold gauge valve.

Figure 37. Charging additional refrigerant

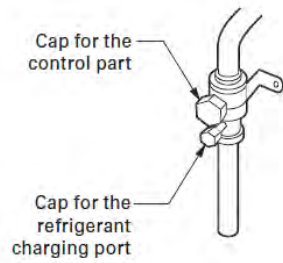


6. Press K2 once to initiate refrigerant charging in cooling mode.
7. To determine if the amount of refrigerant added is correct, use the automatic refrigerant function (see “Refrigerant Amount Detection Operation” p. 79).

## Refrigerant

---

8. After charging the refrigerant, close both caps as shown in the figure below.
- Tightening torque for refrigerant port cap: 7.4–8.9 lbf-ft
  - Tightening torque for control cap: 14.8–18.4 lbf-ft
  - Opening/closing torque for the valve (> 3/4 in.): 7.4 lbf-ft





# Control System

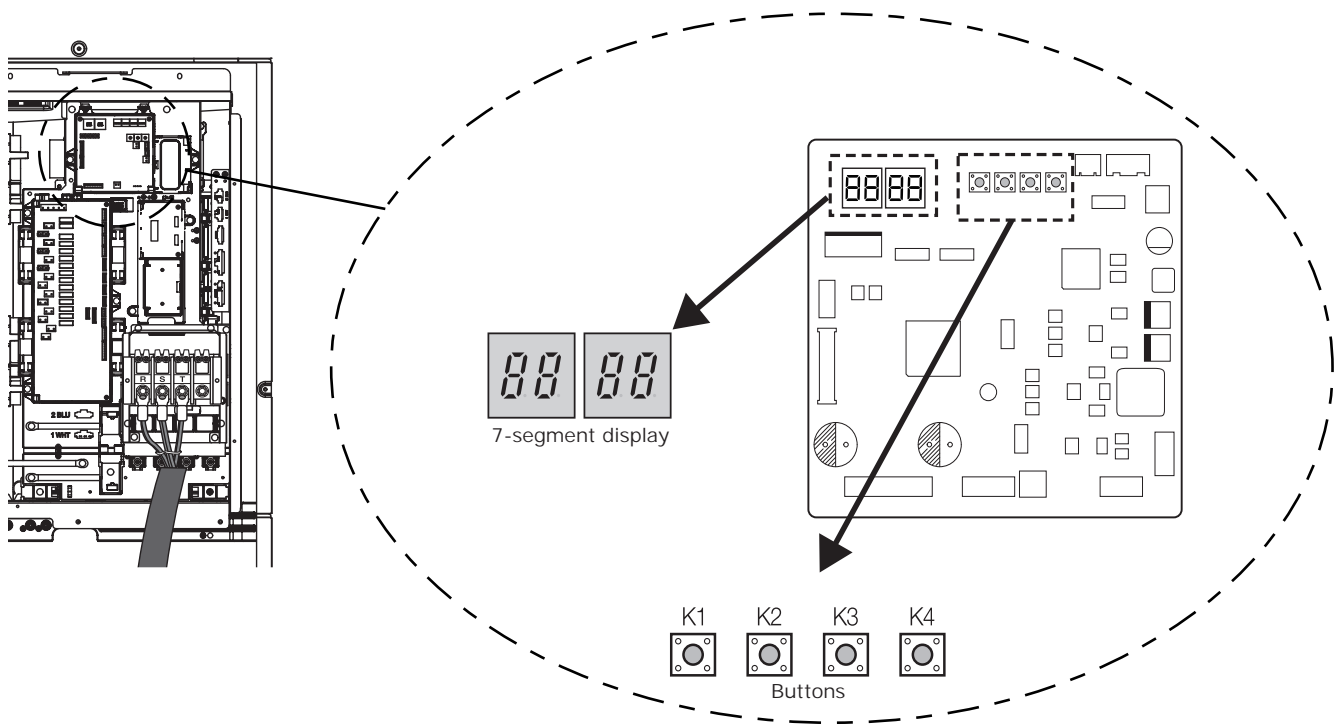
The control board contains a 7-segment display, a DIP switch, three rotary switches, and four buttons, as shown in [Figure 38](#). Their functions are explained in this section.

**⚠ WARNING**

**Hazardous Voltage!**

Before making contact with the inverter circuit board, wait for at least 15 minutes after powering down the outdoor unit to allow the unit to fully discharge high DC voltage. Failure to allow the high DC voltage to discharge completely could result in death or serious injury.

Figure 38. Control board



## Monitoring System Power and Communication Status

The 7-segment display indicates system power and communication status.

Table 40. 7-segment display

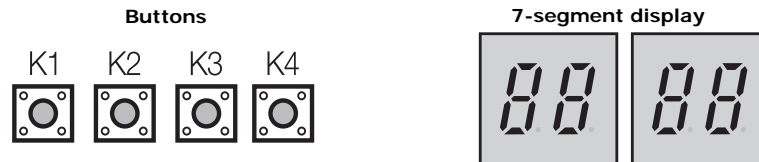
Event	Digit 1	Digit 2	Digit 3	Digit 4
Power up <sup>(a)</sup>	"8"	"8"	"8"	"8"
Establishing communication between outdoor and indoor units	"A"	"d"	Number of connected indoor units	
Transmit/receive (normal operation)	Indoor unit: "A" MCU <sup>(b)</sup> : "C"	Indoor unit: "0" MCU: "1"	Unit address (decimal number)	

(a) 7-segment display example showing power-up is shown in [Figure 38](#).  
 (b) Mode change unit.

## System Configuration

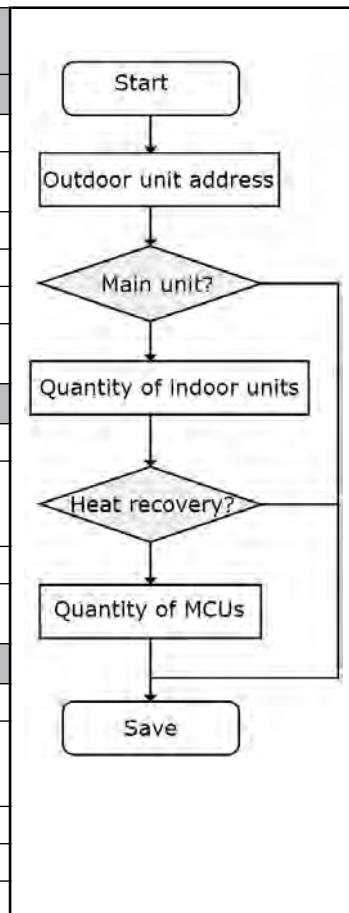
The outdoor unit control board contains buttons K1 – K4 for configuring the system as described in this section.

**Figure 39. Buttons K1–K4 and 7-segment display on the outdoor unit control board**



**Table 41. Procedure for outdoor unit installation settings**

Step	Button	7-segment display	Description	Note
<b>Outdoor unit address</b>				
Step1	—	od nd	Setting required	—
Step2	Press (K1+K2) for 2 seconds	od 00	Unit address for module combination	00: Main unit
	K4 x 1 time	od 01		01: Sub1 unit
	K4 x 2 times	od 02		02: Sub2 unit
	K4 x 3 times	od 03		03: Sub3 unit
Step3	If it is the main unit, go to step 4. Otherwise, press K2 button for 2 seconds to save and exit. (The system will be reset.)			
<b>Quantity of indoor units</b>				
Step4	Press K1	id 00	Ready to set	—
Step5	K2 x n times	id X0	Tens digit (0–6)	Example) 03: 3 units 64: 64 units
	K4 x n times	id 0X	Ones digit (0–9)	
K4: Press for 2 seconds for automatic detection of indoor unit quantity.				
Step6	If it is a heat recovery model, go to step 7. Otherwise, press K2 button for 2 seconds to save and exit. (The system will be reset.)			
<b>Quantity of MCUs<sup>(a)</sup></b>				
Step7	Press K1	nc 00	Ready to set	—
Step8	K2 x n times	nc X0	Tens digit (0–1)	Example) 03: 3 units 16: 16 units
	K4 x n times	nc 0X	Ones digit (0–9)	
K4: Press for 2 seconds for automatic detection of MCU quantity.				
Step9	K2: long	Ad 00	Save	Restart
<b>Note:</b> Press K1 for 2 seconds to exit without save regardless of setting step.				



(a) Applies to heat recovery models only.

To set options:

1. When the unit is not operating, press and hold K2 (5 seconds) to enter the option setting mode. The 7-segment display will appear as shown. (If compressor cut-off is enabled, digit 4 will be "1" or "2".)



2. To select a different option, press K1 repeatedly until the number representing the selected option appears for digits 1 and 2. (See the "Digit 1" and "Digit 2" columns in Table 42, p. 67 for the list of option numbers.) For example, choose "01" on the main outdoor unit to select the cooling capacity correction option.



Digits 1 and 2 change to the number representing the selected option.

3. To change the value for the option selected in Step 2, press K2 repeatedly for 1 second until the number representing the selected value appears for digits 3 and 4. (See the "Digit 3" and "Digit 4" columns in Table 42, p. 67 for the list of values.)

For example, if you select "01" for digits 1 and 2, and "04" for digits 3 and 4, the cooling capacity correction selection is 50–53.6°F (10–12°C).



Digits 3 and 4 change to the number representing the selected value.

4. To save the value you have selected in Step 3, press and hold the K2 for 5 seconds. The 7-segment display will blink as it enters tracking mode. The selected value will be saved when the display returns to normal.

**Note:** To the previous value instead of saving the selection, press and hold K1 (5 seconds). To restore the factory default, press and hold K4 while in the option setting mode.

Table 42. System configuration using K1, K2, and the 7-segment display

Option	Outdoor unit	Digit 1	Digit 2	Digit 3	Digit 4	Value	Comments
Emergency operation for compressor malfunction	Single	0	0	0	0	Disabled (factory default)	E560 will occur if all compressors are set to malfunction state.
				0	1	Compressor 1: malfunction state	
				0	2	Compressor 2: malfunction state	
Cooling capacity correction	Main	0	1	0	0	44.6–48.2 (7-9): factory default	Targeted evaporating temperature: °F(°C). When low temperature value is set, indoor unit discharged air temperature will decrease.
				0	1	41-44.6 (5-7)	
				0	2	48.2-51.8 (9-11)	
				0	3	50-53.6 (10-12)	
				0	4	51.8-55.6 (11-13)	
				0	5	53.6-57.2 (12-14)	
				0	6	55.4-59 (13-15)	

## Control System

**Table 42. System configuration using K1, K2, and the 7-segment display (continued)**

Option	Outdoor unit	Digit 1	Digit 2	Digit 3	Digit 4	Value	Comments
Heating capacity correction	Main	0	2	0	0	435.1 (3.0): factory default	Targeted high pressure: MPa (psi) When low pressure value is set, discharged air temperature of the indoor unit will decrease.
				0	1	362.6 (2.5)	
				0	2	377.1 (2.6)	
				0	3	391.6 (2.7)	
				0	4	406.1 (2.8)	
				0	5	420.6 (2.9)	
				0	6	449.6 (3.1)	
				0	7	464.1 (3.2)	
Current restriction rate	Single	0	3	0	0	100%: factory default	Enabling this setting may decrease cooling and heating performance.
				0	1	95%	
				0	2	90%	
				0	3	85%	
				0	4	80%	
				0	5	75%	
				0	6	70%	
				0	7	65%	
				0	8	60%	
				0	9	55%	
				1	0	50%	
				1	1	No restriction	
Oil collecting interval	Main	0	4	0	0	Factory default	
				0	1	Shortens interval by 1/2	
Temperature for triggering defrost operation	Main	0	5	0	0	Factory default	
				0	1	Enable when installation is in a humid area such as near a river or lake	
Outdoor unit fan speed correction	Single	0	6	0	0	Factory default	Enables the silent mode for night-time in cooling mode (operates automatically depending on the temperature.) However, if the external contact interface module is used, entering the silent mode is available with contact signal in cooling and heating mode.
				0	1	Increase fan speed to maximum value	
Silent mode	Main	0	7	0	0	Disabled (factory default)	
				0	1	Level 1/Auto	
				0	2	Level 2/Auto	
				0	3	Level 3/Auto	
				0	4	Level 1/External contact	
				0	5	Level 2/External contact	
High-head condition setting	Main	0	8	0	0	Disabled (factory default)	When the outdoor unit is 131.23–262.47 ft above the indoor unit.
				0	1	Case 1: height difference type 1 (indoor unit is lower than outdoor unit)	
				0	2	Case 2: height difference type 1 (indoor unit is lower than outdoor unit)	When the outdoor unit is more than 262.47 ft. above the indoor unit.
				0	3	Height difference type 2 (outdoor unit is lower than indoor unit)	When the indoor unit is more than 98.43 ft above the outdoor unit.

**Table 42. System configuration using K1, K2, and the 7-segment display (continued)**

Option	Outdoor unit	Digit 1	Digit 2	Digit 3	Digit 4	Value	Comments
Long piping condition <sup>(a)</sup>	Main	0	9	0	0	Disabled (factory default)	When the equivalent length of the farthest indoor unit from the outdoor unit is between 328.08–557.74.
				0	1	Level 1	
				0	2	Level 2	When equivalent length of farthest indoor unit from the outdoor unit is over 557.74 ft.
Energy saving mode	Main	1	0	0	0	Disabled (factory default)	If enabled, energy saving mode triggers when the room temperature reaches setpoint while operating in heating mode.
				0	1	Enabled	
Rotation defrost	Main	1	1	0	0	Disabled (factory default)	If enabled, continuous heating operation is possible but heating performance will decrease during rotation defrost operation.
				0	1	Enabled	
Expand operational temperature range for cooling operation <sup>(b)</sup>	Main	1	2	0	0	Disabled (factory default)	If enabled, continuous cooling operation is possible even in low temperature condition down to 5°F (-15°C), but MCU noise will increase.
				0	1	Enabled	
Channel address	Main	1	3	A	U	Automatic setting (factory default)	Used for centralized control.
				0–15		Manual setting for channel: 0–15	
Snow accumulation prevention control	Main	1	4	0	0	Enabled (factory default)	If enabled, the fan may rotate when the unit is not operating.
				0	1	Disabled	

(a) Enabling this setting is unnecessary if high-head condition is set.

(b) Heat recovery only.

# Initiating System Operations

Buttons K1 and K2 are also used to initiate system operations. The 7-segment display responds as shown in the last column of the following tables.

**Table 43. Button K1**

Number of times button K1 is pressed	Operation	7-segment display
1 (hold for 5 seconds)	Test operation	K - K- Blank - Blank
1	Refrigerant charging in heating mode	K - 1 - Blank - Blank
2	Test operation in heating mode	K - 2 - Blank - Blank
3	Pump out in heating mode (Outdoor unit address 1)	K - 3 - Blank - 1
4	Pump out in heating mode (Outdoor unit address 2)	K - 3 - Blank - 2
5	Pump out in heating mode (Outdoor unit address 3)	K - 3 - Blank - 3
6	Pump out in heating mode (Outdoor unit address 4)	K - 3 - Blank - 4
7	Vacuuming (Outdoor unit address 1)	K - 4 - Blank - 1
8	Vacuuming (Outdoor unit address 2)	K - 4 - Blank - 2
9	Vacuuming (Outdoor unit address 3)	K - 4 - Blank - 3
10	Vacuuming (Outdoor unit address 4)	K - 4 - Blank - 4
11	Vacuuming (All)	K - 4 - Blank - A
12	End operation	—

**Table 44. Button K2**

Number of times button K2 is pressed	Operation	7-segment display
1	Refrigerant charging in cooling mode	K - 5 - Blank - Blank
2	Test operation in cooling mode	K - 6 - Blank - Blank
3	Pump down all units in cooling mode	K - 7 - Blank - Blank
4	Pipe inspection (heat pump: test operation)	K - 8 - Blank - Blank
5	Checking the amount of refrigerant	K - 9 - X - X (last digits may differ depending on status)
6	Discharge mode <sup>(a)</sup>	K - A - Blank - Blank
7	Forced defrost	K - B - Blank - Blank
8	Forced oil collection	K - C - Blank - Blank
9	Inverter check compressor 1 <sup>(b)</sup>	K - D - Blank - Blank
10	Inverter check for compressor 2 <sup>(b)</sup>	K - E - Blank - Blank
11	Inverter check for fan 1 <sup>(b)</sup>	K - F - Blank - Blank
12	Inverter check for fan 2 <sup>(b)</sup>	K - G - Blank - Blank
13	End operation	—

(a) Discharge mode may not operate normally if an error code occurs. If an E464 or E364 error occurs, do not use the discharge mode because the power element may be damaged.

(b) If button K2 is pressed the specified number of times and the inverter check is not successful, an error code will appear on the 7-segment display.

Button K3 is used to initialize operation.

**Table 45. Button K3**

Number of times button K3 is pressed	Operation	7-segment display
1	Initialize (reset) operation	Same as power up: "8888"

## Monitoring System Settings and Software Versions

Button K4 is used to monitor system settings and software versions.

**Table 46. Button K4**

Number of times button K4 is pressed	Description	7-segment display	
		Digit 1	Digits 2, 3, 4
1	4TV*0072***** (6 ton)	1	Off, 0, 8
	4TV*0096***** (8 ton)		Off, 1, 0
	4TV*0120***** (10 ton)		Off, 1, 2
	4TV*0144***** (12 ton)		Off, 1, 4
	4TV*0168***** (14 ton)		Off, 1, 8
	4TV*0192***** (16 ton)		Off, 2, 0
2	Command frequency of the compressor 1	2	120 Hz → 1, 2, 0
3	Command frequency of the compressor 2	3	120 Hz → 1, 2, 0
4	High pressure	4	220.46 psi (1.52 MPa) → 1, 5, 2
5	Low pressure	5	62.37 psi (0.43 MPa) → 0, 4, 3
6	Discharge temperature of COMP1	6	188.6°F (87°C) → 0, 8, 7
7	Discharge temperature of COMP2	7	188.6°F (87°C) → 0, 8, 7
8	IPM temperature of COMP1	8	188.6°F (87°C) → 0, 8, 7
9	IPM temperature of COMP2	9	188.6°F (87°C) → 0, 8, 7
10	CT sensor value of COMP1	A	2 A → 0, 2, 0
11	CT sensor value of COMP2	B	2 A → 0, 2, 0
12	Suction temperature	C	28.4°F (-2°C) → -, 0, 2
13	COND Out temperature	D	37.4°F (3°C) → 0, 0, 3
14	Temperature of liquid pipe	E	86°F (30°C) → 0, 3, 0
15	TOP temperature of COMP1	F	176°F (80°C) → 0, 8, 0
16	TOP temperature of COMP2	G	176°F (80°C) → 0, 8, 0
17	Outdoor temperature	H	44.6°F (7°C) → 0, 0, 7
18	EVI inlet temperature	I	59°F (15°C) → 0, 1, 5
19	EVI outlet temperature	J	77°F (25°C) → 0, 2, 5
20	Main EEV1 step	K	2000 steps → 2, 0, 0
21	Main EEV2 step	L	2000 steps → 2, 0, 0
22	EVI EEV step	M	300 steps → 3, 0, 0
23	HR EEV step	N	300 steps → 3, 0, 0
24	Fan step (SSR or BLDC)	O	13 steps → 0, 1, 3
25	Current frequency of COMP1	P	120 Hz → 1,2,0

**Table 46. Button K4 (continued)**

Number of times button K4 is pressed	Description	7-segment display	
		Digit 1	Digits 2, 3, 4
26	Current frequency of COMP2	Q	120 Hz → 1,2,0
27	Suction 2 temperature (HR)	R	28.4°F (-2°C) → -, 0, 2
28	Master indoor unit address	S	If master indoor unit is not selected → Blank, N, D If indoor unit No. 1 is selected as master indoor unit → 0, 0, 1

**Table 47. Button K4 (pressed and held for 3 seconds)**

Number of times K4 is pressed and held 3 seconds	Software version/ Unit address	7-segment display: toggles between (1) and (2)			
		Device (1)	Version (2): examples		
1	Main circuit board version	"MAIN"	"1412"		
2	Hub circuit board version	"HUB"	"1412"		
3	Inverter 1 circuit board version	"INV1"	"1412"		
4	Inverter 2 circuit board version	"INV2"	"1412"		
5	Fan 1 version	"FAN1"	"1412"		
6	Fan 2 version	"FAN2"	"1412"		
7	EEP version	"EEP"	"1412"		
			<b>Digit 1</b>	<b>Digit 2</b>	<b>Digit 3, 4</b>
			<b>Address example</b>		
8(a)	Automatically assigned unit addresses	"AUTO"	Indoor unit: "A" MCU: "C"	Indoor unit: "0" MCU: "1"	"07"
9(a)	Manually assigned unit addresses	"MANU"	Indoor unit: "A"	Indoor unit: "0"	"15"

(a) Toggles between indoor unit and MCU.



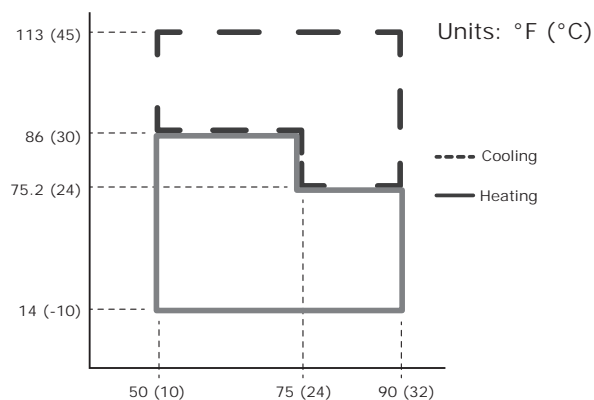
## Automatic Port Addressing Operation

The automatic port addressing operation applies only to 2nd generation MCUs (4MCUTV\*). You can use it to automatically set the address of each MCU port that is connected to an indoor unit. If an MCU port is set incorrectly or a pipe between an MCU and an indoor unit is connected incorrectly, the indoor unit in error will be indicated.

**Note:** *If an Outdoor Air Processing (OAP) Duct or Hydro Unit is connected, set the MCU port addresses manually.*

### Requirements Prior to Performing the Operation

- Ensure that the service valve of the outdoor unit is open.
- Ensure that the power and communication cables of the indoor and outdoor units are correctly connected.
- Use a voltmeter and a phase tester to verify that the voltages and phases are correct:
- R,S,T terminal: check the 460V between wires (R-S, S-T,T-R) / 230V between wires (R-S, S-T,T-R).
- Turn on the outdoor and indoor unit 6 hours before the operation is to be performed so that both units are warmed up sufficiently.
- Set the installation options on the devices (indoor unit, MCU, and any others) that are connected to the outdoor unit.
- Ensure that the outdoor unit front cabinet is closed.
- Check the operating temperature. If this operation is run at a temperature that is out of operating temperature range, the automatically set addresses may be incorrect. In this case, use a manual address-setting procedure.



#### Notes:

- *The automatic port addressing operation will begin approximately 3 minutes after power on and reset.*
- *Before MCU port addresses are automatically set, MCU port setting errors (E216, E217, or E218) may occur. You can run the automatic port addressing operation regardless of these errors.*

### Performing the Operation

1. On the outdoor unit main control board, press the **K2** button 13 times to start the automatic port addressing operation: Display:  $\overline{\text{FH}}\overline{00}$

	Outdoor temperature < 75°F (24°C)	75°F (24°C) ≤ Outdoor temperature < 86°F (30°C)	86°F (30°C) ≤ Outdoor temperature
Indoor temperature < 24°C	Main heating operation	Main heating operation	Main cooling operation
Indoor temperature ≥ 24°C	Main heating operation	Main cooling operation	Main cooling operation

Each step is indicated on the outdoor unit display:

Step 1 (Start  $\overline{\text{FH}}\overline{01}$ ) > Steps 2 to 8 (Setup  $\overline{\text{FH}}\overline{08}$ ) > Step 9 (Check  $\overline{\text{FH}}\overline{09}$ ) > Step 10 (Confirmation  $\overline{\text{FH}}\overline{10}$ )

The entire operation usually takes 25 to 55 minutes, depending on the number of connected indoor units. However, it may take up to 2 hours to complete the operation in order to protect the compressor.

### Result

When the operation is finished, the following data is shown on the outdoor unit 7-segment display:

**E191**: operation is finished

**E191** and indoor unit data display alternately as follows:

- Digit **1,2** = indoor unit address
- Digit **3,4** = error status
  - **00**: An MCU port is turned on but an IDU is not connected.
  - **01**: A cooling only indoor unit is connected to the MCU.
  - **02**: The shared setting for two ports is incorrect.
- **Example**: When the MCU port connected to the indoor unit 12 is disabled, **E191** and **1200** are displayed alternately.

**Note**: If multiple indoor units have setting errors, each time the **K2** button is pressed, the data for the next indoor unit with errors is displayed.

# Pre-Start Checks

After installation and before the test operation is conducted, perform the following pre-start checks:

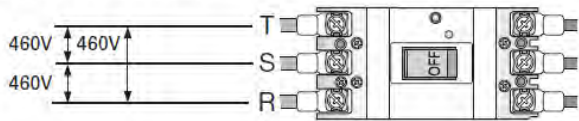
**NOTICE**

**Avoid Damage to the Communication Circuit!**

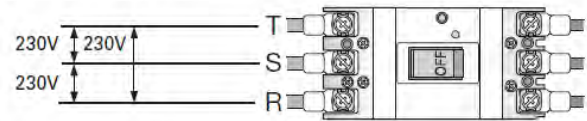
**Do not measure the communication terminal with an insulation tester. Doing so will damage the communication circuit.**

1. Ensure that the power and communication cables of the indoor and outdoor units are properly connected.
2. Before supplying power, use a 500 Vdc (4TV\*\*\*\*\*400N\*) or 600 Vdc (4TV\*\*\*\*\*300N\*) insulation resistance tester to measure the power terminal (3 phase: R, S, T) and the outdoor unit grounding. The resistance measurement should be over 30 MΩ .
3. Before supplying the power, use a voltmeter and phase tester to check the voltage and the phase between wires (R-S, S-T, T-R): 460 V (TV\*\*\*\*\*400N\*) or 230 V (4TV\*\*\*\*\*300N\*).

4TV\*\*\*\*\*400N\*



4TV\*\*\*\*\*300N\*



4. Ensure that the indoor units are connected.
5. The protection system cuts power to the PCB for overvoltage when N phase is cross-wired to the R, S, and T terminals. Check the power connection from N phase if the PCB is not turned on.
6. Check for a short-circuit between the communication terminal and ground.
7. Ensure that the pre-start checklist (Table 48) has been completed.

**Table 48. Pre-start checklist**

<b>Installation</b>	<b>Outdoor unit</b>	<ul style="list-style-type: none"> <li>• Have you checked the external surface and the inside of the outdoor unit for damage?</li> <li>• Is there any possibility of short circuit due to the heat produced by an outdoor unit?</li> <li>• Is the place well-ventilated and meets recommended requirements for clearances and service?</li> <li>• Is the outdoor unit installed securely to withstand the external force?</li> </ul>
	<b>Indoor unit</b>	<ul style="list-style-type: none"> <li>• Have you checked the external surface and the inside of the indoor unit?</li> <li>• Is there enough space for service?</li> <li>• Have you ensured that the center of the indoor unit is installed horizontally and is level?</li> </ul>
<b>Refrigerant pipe</b>		<ul style="list-style-type: none"> <li>• Have you selected the correct pipes?</li> <li>• Are the liquid and gas valve open?</li> <li>• Is the total number of connected indoor units within the allowable range?</li> <li>• Are the length and the height difference between the refrigerant pipes within the allowable range?</li> <li>• Are the Y-joints properly installed?</li> <li>• Has the connection of liquid and gas pipes been correctly performed?</li> <li>• Have you selected correct insulator for pipes and insulated them correctly?</li> <li>• Is the pipe or connection part properly insulated?</li> <li>• Is the quantity of the additional refrigerant correctly weighed in? (You must record the amount of additional refrigerant charging on the service record paper placed outside the outdoor unit.)</li> </ul>

## Pre-Start Checks

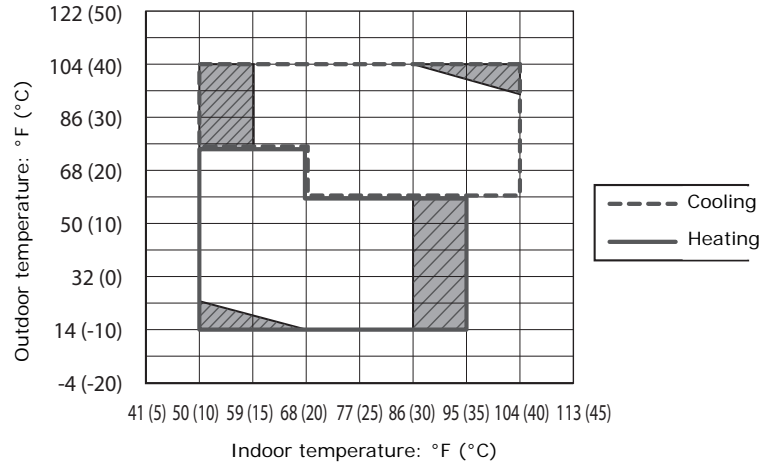
---

**Table 48. Pre-start checklist**

<b>Electrical</b>	<ul style="list-style-type: none"><li>• Are the power cable and communication cable tightened firmly on the terminal board within the rated torque recommendations?</li><li>• Have you checked for cross connection of the power and communication cables?</li><li>• Have the outdoor unit been properly grounded? Is shielded cable used for the communication cable?</li><li>• Is the wire length within the recommended limit?</li><li>• Is the wiring route correct?</li></ul>
<b>Setting address</b>	<ul style="list-style-type: none"><li>• Are the address of the indoor and outdoor units properly set?</li><li>• Are the address of the indoor and outdoor units properly set (when using multiple remote controllers)?</li></ul>
<b>Option</b>	<ul style="list-style-type: none"><li>• Ensure that the isolation frame is correctly installed.</li></ul>

# Test Operation

Perform the test operation after all pre-start checks have been completed (See “Pre-Start Checks” p. 75) and within the following temperature conditions:



**Notes:**

- During the test operation, cooling/heating modes are selected automatically.
- In the temperature range marked with hashed lines, system protection control may trigger during operation. (If this occurs, the test operation may be difficult to judge correctly.)
- When the temperature is outside of the guaranteed range, test operation accuracy of may decrease to the borderline area shown in the graph.

## ⚠ WARNING

### Hazardous Voltage, Rotating Components!

Do not operate the product with the panel or duct outlet protection net off. There is risk of personal injury from parts that rotate or contain high voltage.

## ⚠ CAUTION

### Risk of Burn or Frostbite!

Refrigerant pipe may be hot or cold during or right after the operation depending on the status of the refrigerant which flows through the refrigerant pipe, compressor, and other parts of the refrigerant cycle. Do not touch the refrigerant pipe during or right after the operation to avoid getting burned or frostbit.

## NOTICE

### Avoid Unit Damage!

Wait at least 5 minutes before turning off the main power after the inspection test is finished. If you do not, water leakage or other problems may occur.

Wait at least 6 hours after power is supplied to the outdoor unit before operating it to allow time for the crank case heater to pre-heat. If the crank case heater is not pre-heated before operation, unit parts are at risk of being seriously damaged.

1. Provide power to the outdoor unit at least 6 hours before operating it.

**Notes:** When power is supplied to the outdoor unit, it will check for and verify communications with the indoor units.

2. Ensure that the front of the outdoor unit is closed.

## Test Operation

---

3. Press and hold button K1 for 5 seconds to run the test operation (see [Table 43, p. 70.](#))
  - While the test operation is running and after the communication check, **UP (UnPrepared)** appears on the digital display and the compressor is restricted from operating. The display will clear automatically when the test operation is completed.
  - The test operation may proceed from 20 minutes to maximum 2 hours depending on the operating status.
  - During the test operation, noise may occur due to valve inspection. (Examine the unit if abnormal noise continually occurs.)
4. If error codes occur during the test operation, refer to the VRF Technician Utilities Tool (TUT) or the VRF service manual (VRF-SVM046\*) for details.
5. When the test operation ends, use VRF Enterprise Management Software or VRF Auto Commissioning Tool to issue a test results report. If any items in the report are marked with an “inspection required” sign, refer to the service manual for information on correcting the items and run the test operation again.
6. Ensure the following:
  - The system has the correct refrigerant amount (see [“Refrigerant Amount Detection Operation” p. 79](#)) after the unit has been operating in cooling mode for at least 30 minutes
  - Cooling/heating operation runs normally.
  - Air flow direction and fan speed of indoor units runs normally.
  - There are no abnormal operating noises from indoor or outdoor units.
  - During cooling operation, the indoor units drain properly.
7. Use VRF Enterprise Management Software to check operating status details.
8. Explain to the user how to use the indoor unit, and leave indoor unit manual with the user for their reference.

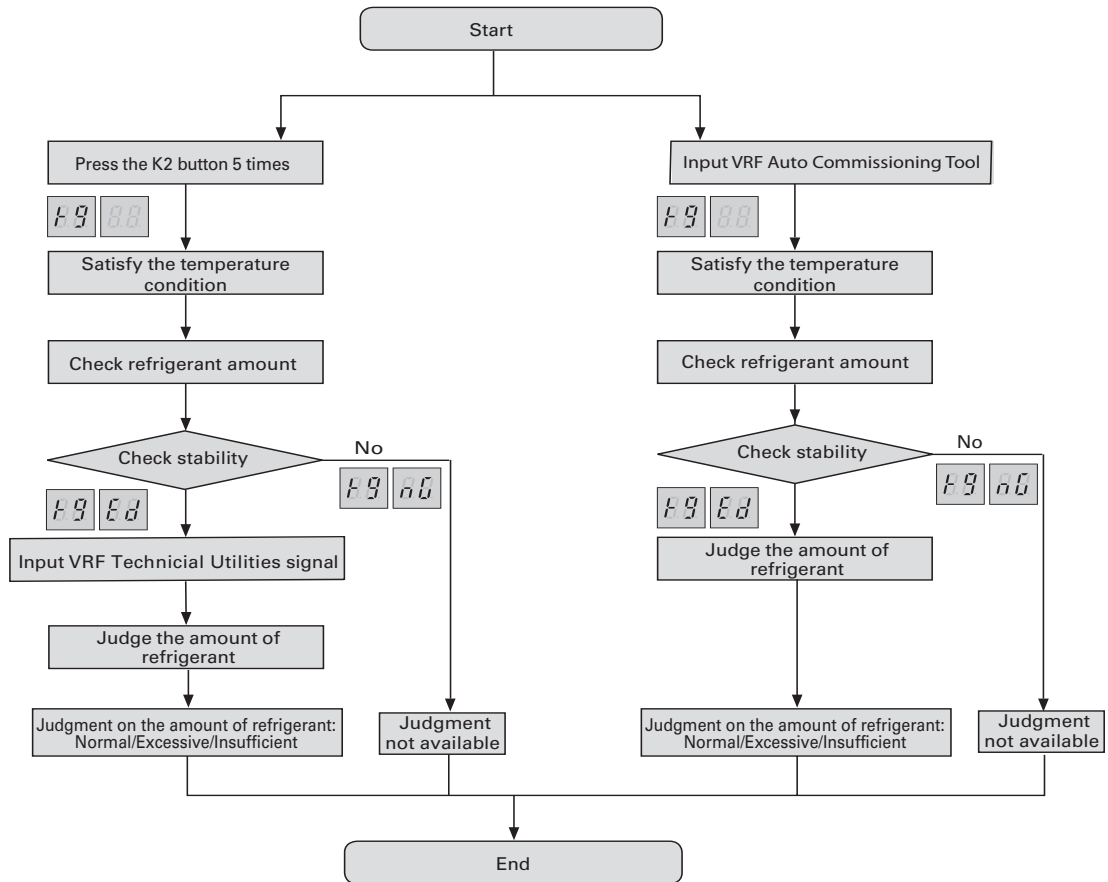
# Refrigerant Amount Detection Operation

Perform the refrigerant amount detection operation only under after the unit has been operating in cooling mode for at least 30 minutes.

If the unit operation cycle is unstable, the refrigerant detection operation may end before it is completed.

The refrigerant detection operation result may be inaccurate if

- If the refrigerant detection operation is run after the unit has been shut down for a long period of time.
- If the unit installation environment causes the unit to trigger protection controls.



After the refrigerant detection operation is complete, take the following actions:

- If the amount of refrigerant is excessive, discharge 5% of the detected amount and restart the refrigerant amount detection operation.
- If the amount of refrigerant is insufficient, add 5% of the detected amount and restart the refrigerant amount detection operation.
- If the degree of supercooling is insufficient, add 10% of the detected amount of refrigerant and restart the refrigerant amount detection operation.
- If the result is unavailable, check that the refrigerant detection operation was executed within the guaranteed temperature range. Perform a test operation to determine if there are any other problems with the system.

## Error Codes

For interpreting error codes, refer to the list of error codes in the Technician Utilities Tool (TUT) or the Service Manual for VRF Outdoor and Indoor Units (VRF-SVM046\*).









Ingersoll Rand (NYSE:IR) advances the quality of life by creating comfortable, sustainable and efficient environments. Our people and our family of brands—including Club Car®, Ingersoll Rand®, Thermo King® and Trane®—work together to enhance the quality and comfort of air in homes and buildings; transport and protect food and perishables; and increase industrial productivity and efficiency. We are a global business committed to a world of sustainable progress and enduring results. For more information, visit [www.ingersollrand.com](http://www.ingersollrand.com).

The manufacturer has a policy of continuous product and product data improvement and reserves the right to change design and specifications without notice.