

CSAA USIZ 03-35 (NON HURRICANE UNITS)  
 PSCA INTERNAL WIDTH 48-96

B

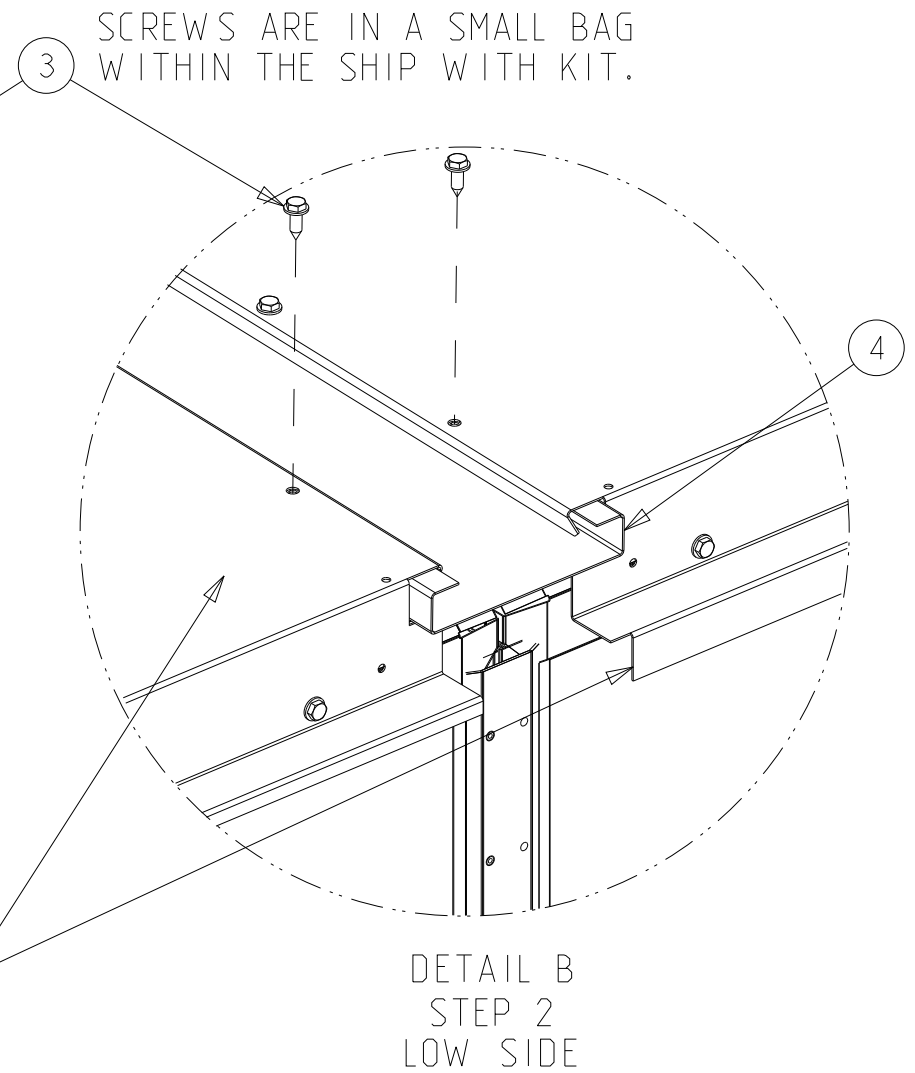

SCREWS ARE IN A SMALL BAG  
 WITHIN THE SHIP WITH KIT.

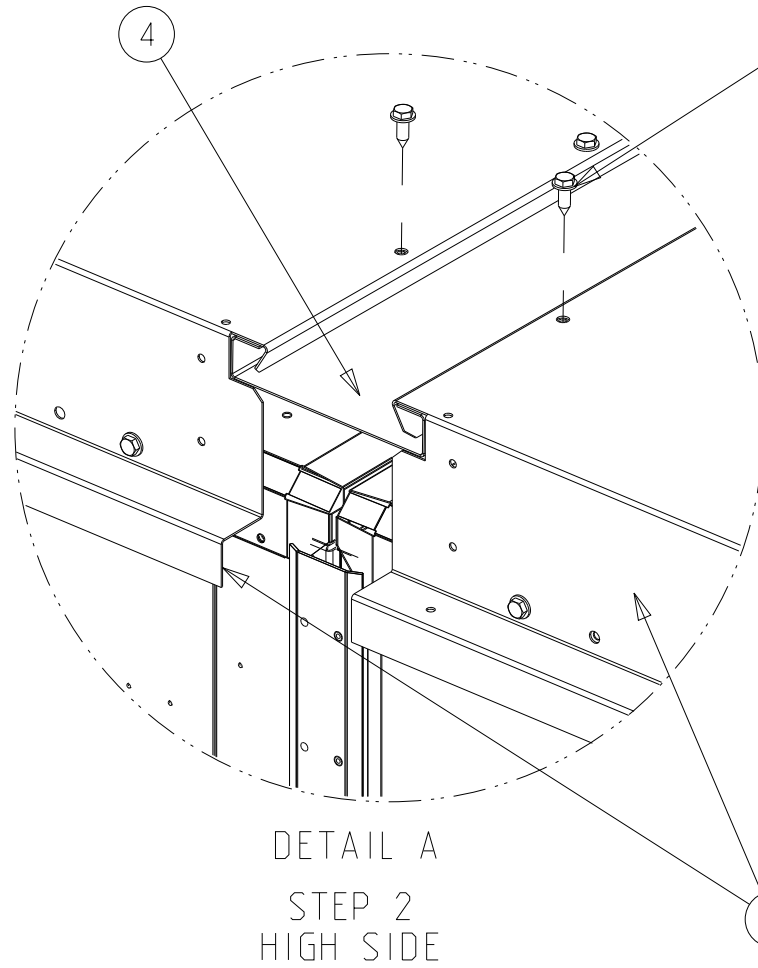
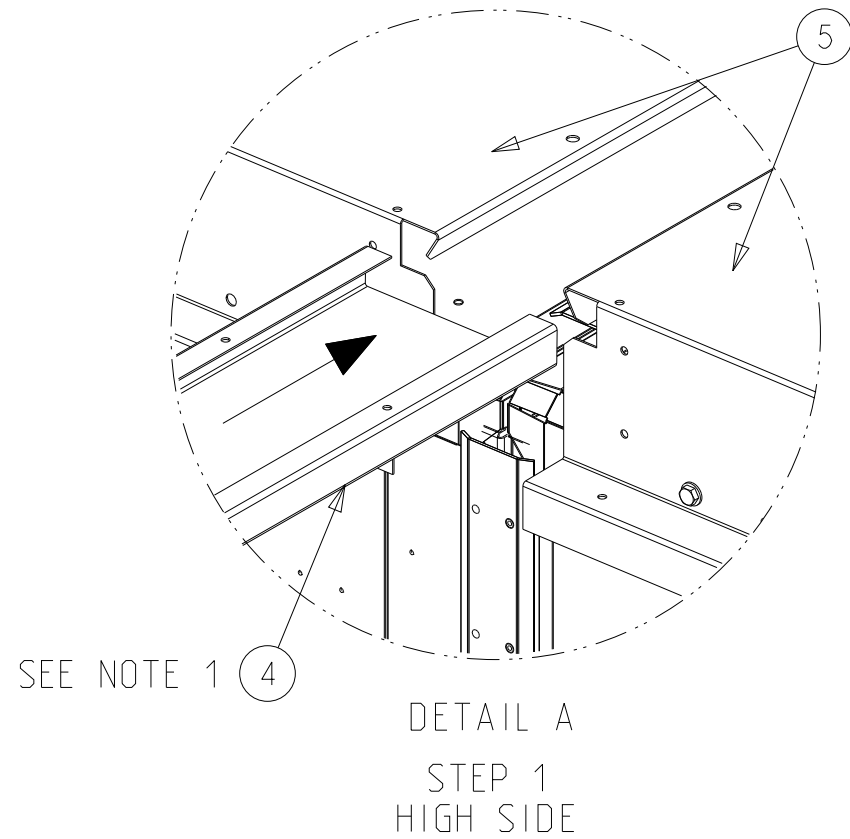
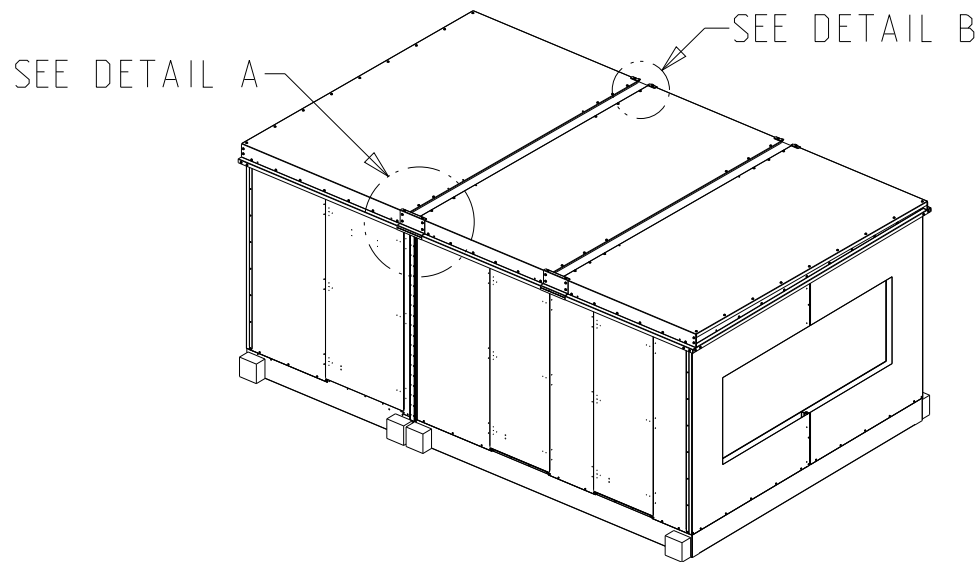

A

INSTRUCTIONS:

1. SLIDE THE C-CHANNEL, ITEM# 4 FROM SIDE OF THE ROOF AT SHIPPING SPLIT.
2. C CHANNEL SHOULD BE FLUSHED WITH THE OUTDOOR ROOF EDGE ON THE HIGHER PITCH SIDE.

PROPRIETARY DATA	
THIS DRAWING IS PROPRIETARY AND SHALL NOT BE COPIED OR IT'S CONTENTS DISCLOSED TO OUTSIDE PARTIES WITHOUT THE WRITTEN CONSENT OF TRANE.	
ITEM	DESCRIPTION
1	SUPPORT BRACKET WITHOUT NOTCH WITH GASKET
2	SUPPORT BRACKET WITH NOTCH WITH GASKET
3	SCREW; .250-14 X .75 LEACHED SELF DRILLER WITH PLASTISOL
4	C CHANNEL
5	OUTDOOR ROOF

OMS #	<b>49514027</b>
SHEET	1 OF 2
SECTION	SHIPPING SPLIT

DESC.	<b>SHIPPING SPLIT INSTALLATION (FIELD INSTALLATION)</b>
-------	---



REVISION HISTORY	
BY	ECT#
ILYAS KHAN	1830964

REV.	A
REV DATE	14-JUN-2018

? OPTIONAL PARTS
▲ VERIFY
● CRITICAL FEATURE

4

3

2

1

B

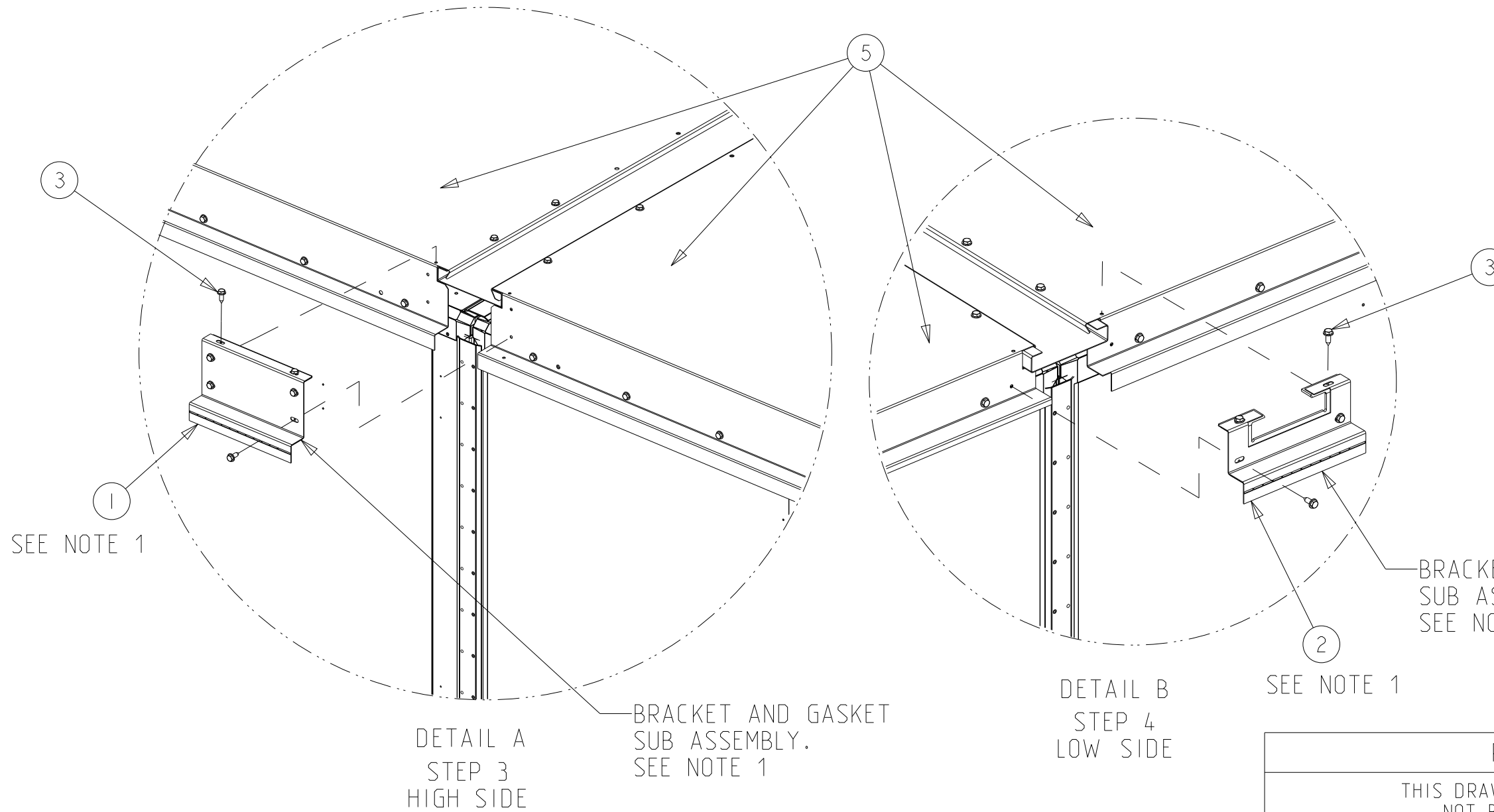

ITEM# 3  
SCREW; .250-14 X .75 LEACHED  
SELF DRILLER WITH PLASTISOL

SEE NOTE 1

DETAIL A  
STEP 3  
HIGH SIDE

BRACKET AND GASKET  
SUB ASSEMBLY.  
SEE NOTE 1

DETAIL B  
STEP 4  
LOW SIDE

BRACKET AND GASKET  
SUB ASSEMBLY.  
SEE NOTE 1

SEE NOTE 1

INSTRUCTIONS:

1. MAKE SURE THERE IS A GASKET ON THE BRACKETS BEFORE INSTALLING, IF NOT PLEASE CONTACT TRANE SERVICE CENTER.
2. ASSEMBLE THE SUPPORT BRACKET, ITEM# 1 ON THE HIGHER PITCH SIDE OF THE ROOF PANEL AT THE SHIPPING SPLIT JOINT USING SCREW (.250-14 X .75 LEACHED SELF DRILLER WITH PLASTISOL) ITEM# 3 (6 QTY).
3. ASSEMBLE THE SUPPORT BRACKET, ITEM# 2 AND ENSURE C CHANNEL PROTRUDES INSIDE THE NOTCH AND THE GASKET SEALS AROUND THE CHANNEL ON THE LOWER PITCH SIDE OF THE ROOF PANEL AT THE SHIPPING SPLIT JOINT USING SCREW (.250-14 X .75 LEACHED SELF DRILLER WITH PLASTISOL) ITEM# 3 (4 QTY).

PROPRIETARY DATA	
THIS DRAWING IS PROPRIETARY AND SHALL NOT BE COPIED OR IT'S CONTENTS DISCLOSED TO OUTSIDE PARTIES WITHOUT THE WRITTEN CONSENT OF TRANE.	
ITEM	DESCRIPTION
1	SUPPORT BRACKET WITHOUT NOTCH WITH GASKET
2	SUPPORT BRACKET WITH NOTCH WITH GASKET
3	SCREW; .250-14 X .75 LEACHED SELF DRILLER WITH PLASTISOL
4	C CHANNEL
5	OUTDOOR ROOF

A

OMS #	<b>49514027</b>
SHEET	2 OF 2
SECTION	SHIPPING SPLIT

DESC.	<b>SHIPPING SPLIT INSTALLATION (FIELD INSTALLATION)</b>
-------	---



REVISION HISTORY	
BY	ECT#
ILYAS KHAN	1830964

REV.	A
REV DATE	14-JUN-2018

- ? OPTIONAL PARTS
- ▲ VERIFY
- CRITICAL FEATURE

4

3

2

1