

DRAWING	REVISION	VERSION
D	D	4

UNLESS OTHERWISE SPECIFIED ALL DIMENSIONS ARE IN INCHES. TOLERANCE:

.X =± 0.0  
 .XX =± 0.00  
 .XXX =± 0.000

FINISH ✓

ANGLES =± 0.0 ° HOLE DIA = ∴

CONFORMS TO ASME Y14.5M-1994.

TRANE

THIS DRAWING IS PROPRIETARY AND SHALL NOT BE COPIED OR ITS CONTENTS DISCLOSED TO OUTSIDE PARTIES WITHOUT THE WRITTEN CONSENT OF TRANE

DRAWN BY: NISARGA S ©TRANE DATE: 06-MAR-2025

DO NOT SCALE PRINT

THIRD ANGLE PROJECTION



S65380476

SHEET 1 OF 7 REV D

DESIGN INTENT  
 FLAT FILTER AVAILABILITY & INSTL

BCXE USIZ 12-120

APPLIES TO:  
 BCHE SIZE 12-120 SIDE AND BOTTOM FILTER BOX  
 BCVE SIZE 72-120 SIDE AND TOP FILTER BOX

NOTE(S):  
 1. BCVE SIZE 24-60 GET INTERNAL MOUNTED FLAT FILTERS.

FILTER AND ACCESSORY COMBINATIONS

	Angle Filter Box	Mix Box	Mix Box with Angle Filters	Return Attenuator	Discharge Attenuator
Flat Filter Rack	N/A	N/A	N/A	N/A	x
Bottom/Top Access Filter Box	N/A	x	N/A	x	x

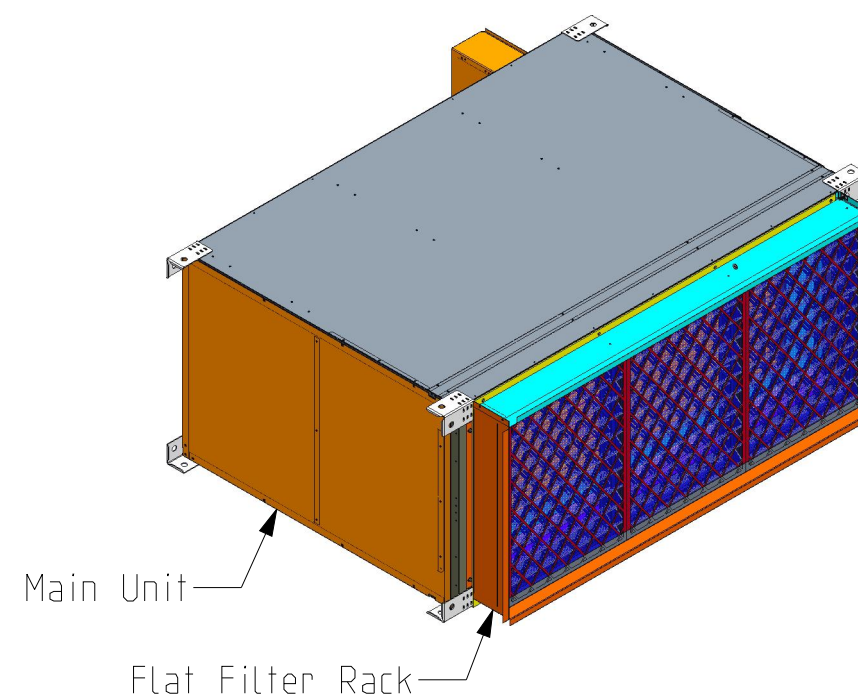

LH HORIZONTAL BLOWER COIL WITH SIDE ACCESS FLAT FILTER

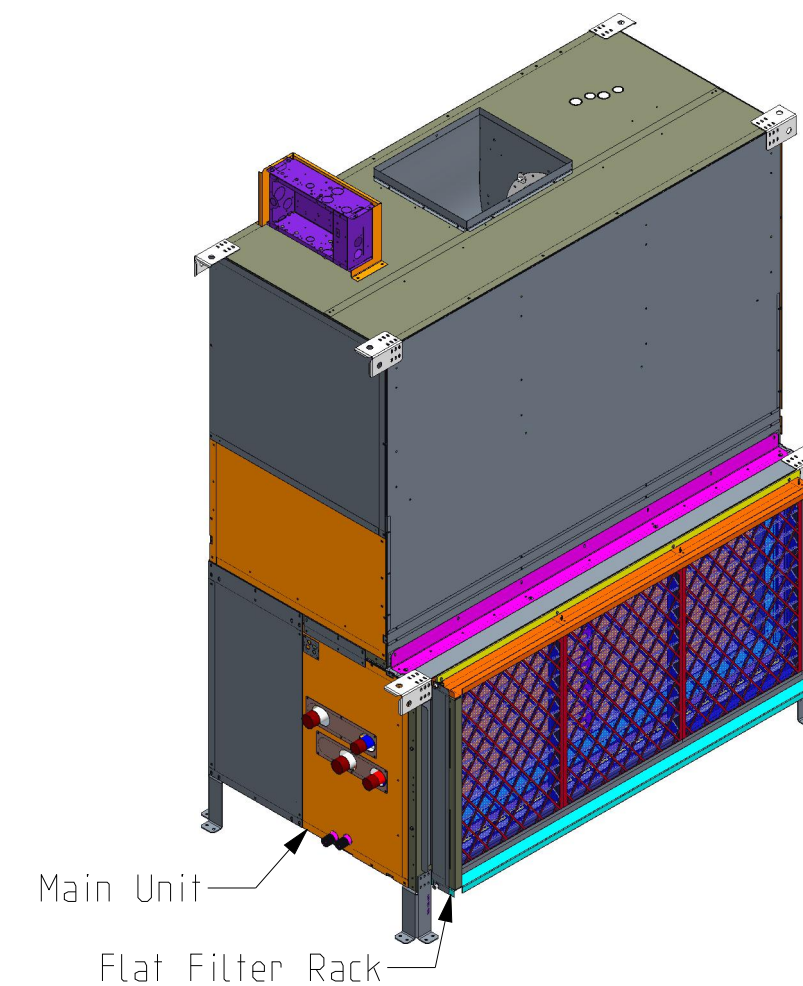

RH VERTICAL BLOWER COIL WITH SIDE ACCESS FLAT FILTER

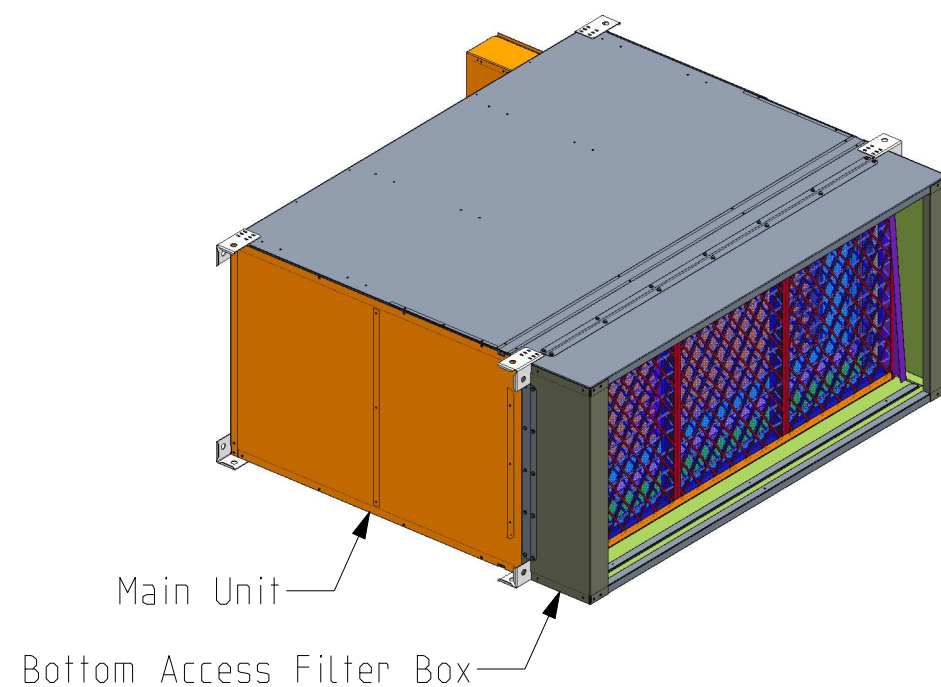

LH HORIZONTAL BLOWER COIL WITH BOTTOM ACCESS FLAT FILTER

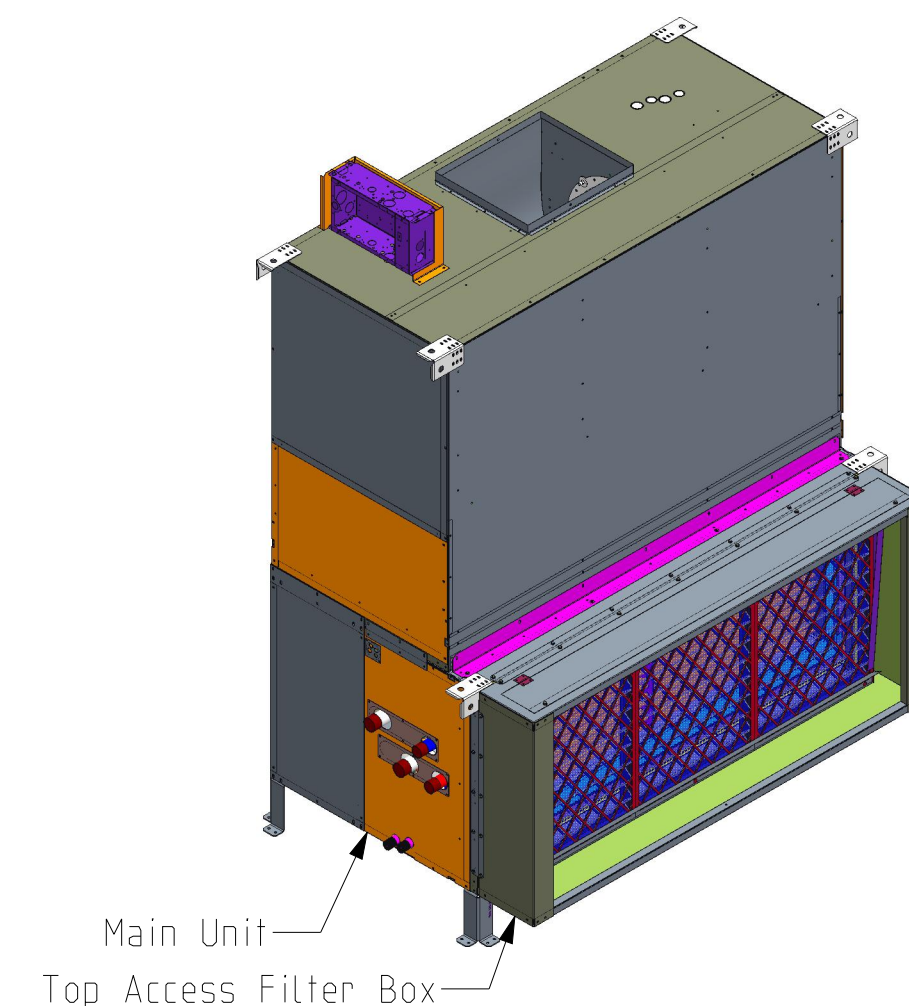

RH VERTICAL BLOWER COIL WITH TOP ACCESS FLAT FILTER

	REVISION	VERSION
DRAWING	D	4

UNLESS OTHERWISE SPECIFIED ALL DIMENSIONS ARE IN INCHES. TOLERANCE:

.X =± 0.0  
 .XX =± 0.00  
 .XXX =± 0.000

ANGLES =± 0.0 ° HOLE DIA = ∴

CONFORMS TO ASME Y14.5M-1994.

FINISH ✓

TRANE

THIS DRAWING IS PROPRIETARY AND SHALL NOT BE COPIED OR ITS CONTENTS DISCLOSED TO OUTSIDE PARTIES WITHOUT THE WRITTEN CONSENT OF TRANE

DRAWN BY: NISARGA S TRANE DATE: 06-MAR-2025

DO NOT SCALE PRINT

THIRD ANGLE PROJECTION

S65380476

SHEET 2 OF 7 REV D

DESIGN INTENT  
 FLAT FILTER AVAILABILITY & INSTL

BCXE USIZ 12-120

# FILTER SIZES

- NOTE(S):
- STANDARD FILTER SIZES ARE USED TO MINIMIZE COST.
  - FILTERS ARE SIZED SO FACE VELOCITIES SAY BELOW 625 FPM AT MAXIMUM UNIT CFM.
  - VELOCITIES AND AIR PRESSURE DROP ARE CALCULATED USING NOMINAL FILTER DIMENSIONS.
  - AIR PRESSURE DROP IS DETERMINED FROM SUPPLIER TESTING  
 $1" TA APD = (1.480E-06) * (CFM / FILTER SQFT)^2 + (2.324E-05) * (CFM / FILTER SQFT) + 3.571E-04$   
 $MERV 8 APD = (2.909E-07) * (CFM / FILTER SQFT)^2 + (2.639E-04) * (CFM / FILTER SQFT) + 7.404E-04$   
 $MERV 13 APD = (5.106E-07) * (CFM / FILTER SQFT)^2 + (4.447E-04) * (CFM / FILTER SQFT) + 1.159E-03$

## NOMINAL DIMENSION (ACTUAL DIMENSION)

Unit Size	nCFM	mCFM	Height (in)	Width 1 (in)	Width 2 (in)	Qty 1	Qty 2	nFPM	mFPM	1" TA nAPD	Merv 8 nAPD	Merv 13 nAPD	Merv 8 + Merv13 nAPD
12	400	500	12 (11.5)	20 (19.5)	N/A	1	N/A	240	300	0.09	0.08	0.14	0.22
18	600	675	12 (11.375)	24 (23.375)	N/A	1	N/A	300	338	0.14	0.11	0.18	0.29
24	800	1000	12 (11.375)	24 (23.375)	N/A	1	N/A	400	500	0.25	0.15	0.26	0.41
36	1200	1600	12 (11.375)	12 (11.75)	24 (23.375)	1	1	400	533	0.25	0.15	0.26	0.41
54	1800	2400	16 (15.75)	16 (15.75)	25 (24.5)	1	1	395	527	0.24	0.15	0.26	0.41
72	2400	3000	16 (15.5)	25 (24.5)	N/A	2	N/A	432	540	0.29	0.17	0.29	0.46
90	3000	4000	24 (23.375)	20 (19.375)	24 (23.375)	1	1	409	545	0.26	0.16	0.27	0.43
120	4000	5000	24 (23.375)	18 (17.375)	N/A	3	N/A	444	556	0.3	0.18	0.3	0.48

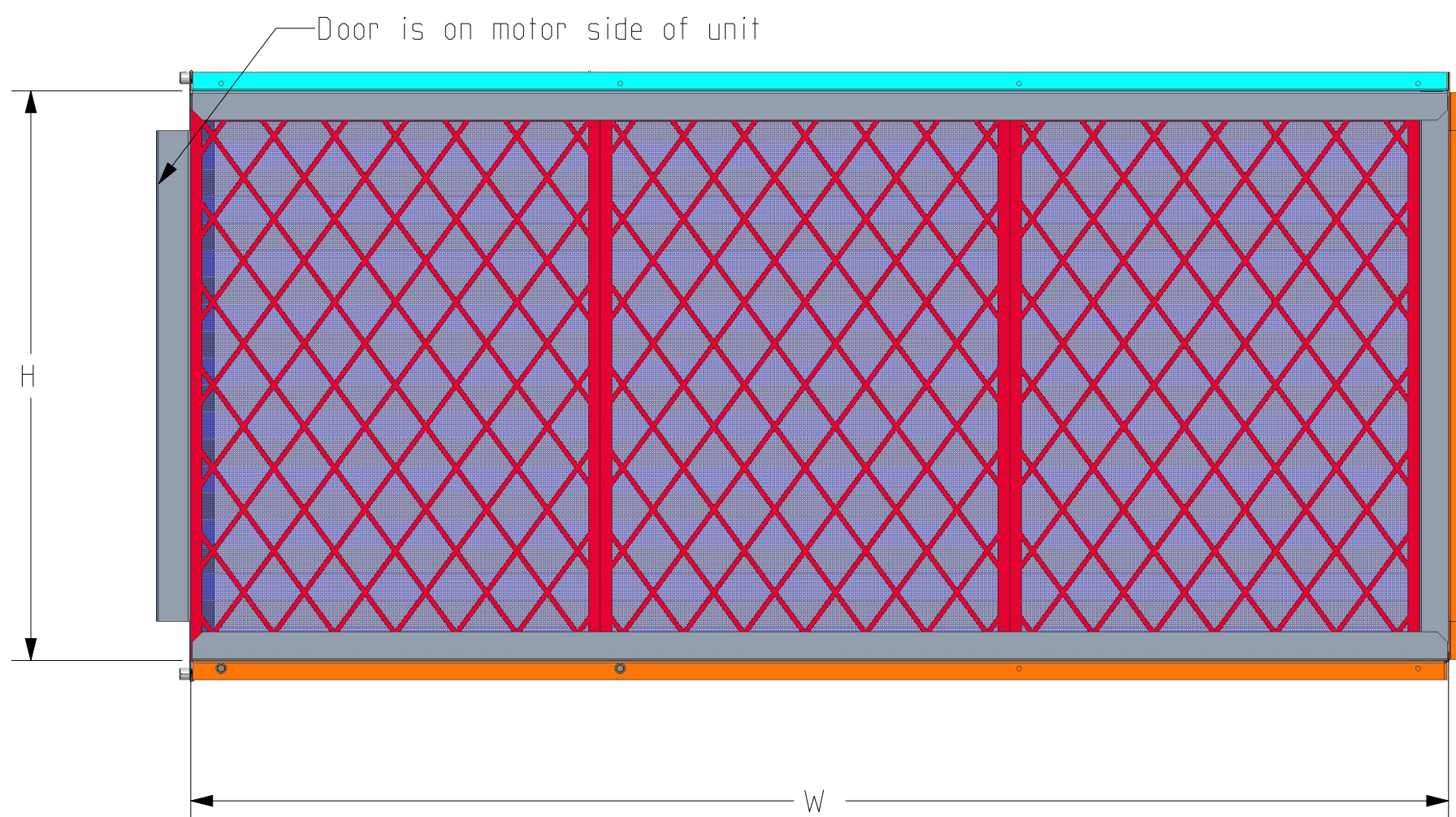

Filter Arrangement for Merv 8/13 Combo Filters

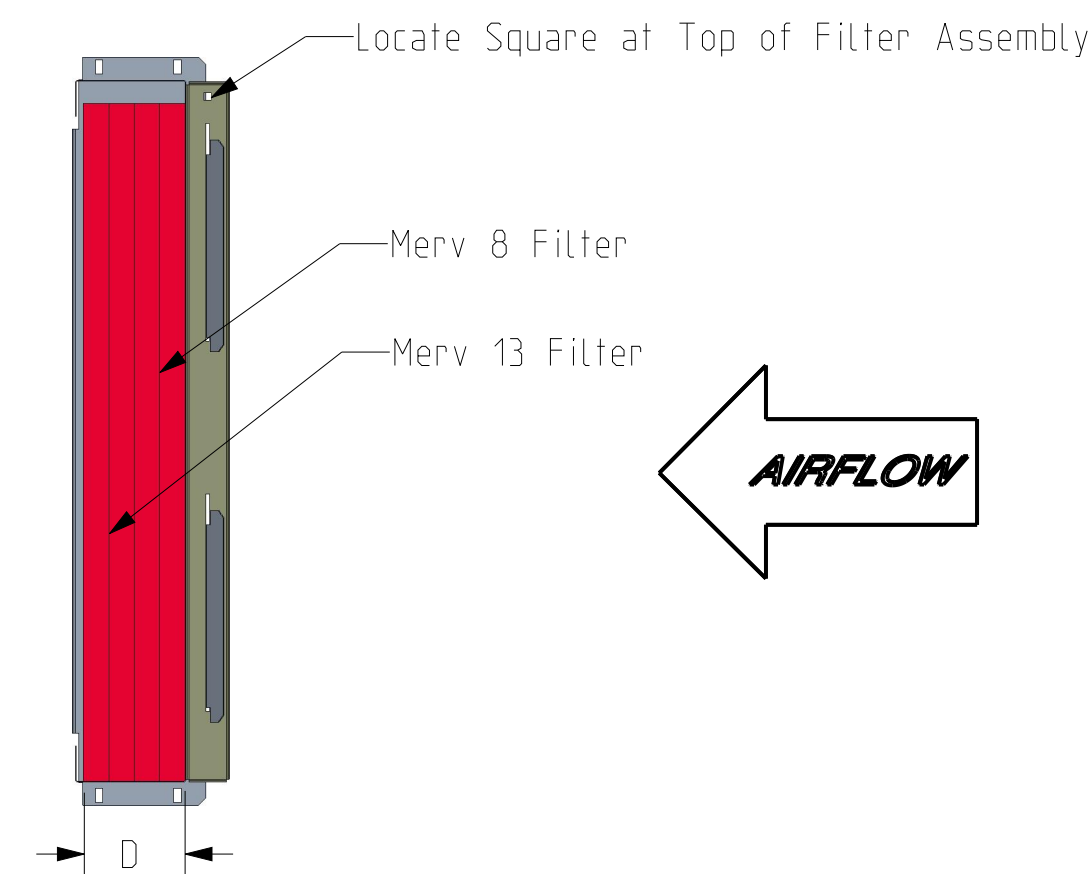

$D = Filter Qty * (Actual Filter Depth + 0.0625)$

$W = (Actual Filter1 Width) + (Actual Filter2 Width) + (Actual Filter3 Width) + (0.125 \times Filter Qty) + Blockoff Width$   
 $H = Actual Filter Height + 0.125 + 2 * (Screw Head Max Height)$

DRAWING	REVISION	VERSION
D	D	4

UNLESS OTHERWISE SPECIFIED ALL DIMENSIONS ARE IN INCHES. TOLERANCE:

.X =± 0.0  
 .XX =± 0.00  
 .XXX =± 0.000

ANGLES =± 0.0 ° HOLE DIA = ∅

CONFORMS TO ASME Y14.5M-1994.

FINISH ✓

TRANE

THIS DRAWING IS PROPRIETARY AND SHALL NOT BE COPIED OR ITS CONTENTS DISCLOSED TO OUTSIDE PARTIES WITHOUT THE WRITTEN CONSENT OF TRANE

DRAWN BY: NISARGA S DATE: 06-MAR-2025

DO NOT SCALE PRINT

THIRD ANGLE PROJECTION

S65380476

SHEET 3 OF 7 REV D

DESIGN INTENT  
 FLAT FILTER AVAILABILITY & INSTL

BCXE USIZ 12-120

# SIDE LOAD FILTER TRACK ASSEMBLY

NOTE(S):

- FOUR FILTER OPTIONS FOR THE FLAT FILTER RACK INCLUDE:  
 1" THROWAWAY FILTERS  
 2" MERV 8 FILTERS OR 2" MERV 13 FILTERS  
 2" MERV 8 + 2" MERV 13 COMBO FILTERS  
 SETS OF EXTRA FILTERS CAN BE ORDERED WITH THE FILTER RACK.
- THE SAME FILTER RACK ASSEMBLY IS USED FOR BOTH RH AND LH UNITS.  
 IT CAN BE ROTATED 180 DEGREES.
- 1" THROWAWAY, 2" MERV 8, AND 2" MERV 13 FILTERS USE THE SAME FRAME PARTS AND WERE SIZED FOR THE WORST CASE ACTUAL FILTER LENGTH AND HEIGHT PLUS FILTER TOLERANCES. FILTERS WITH THE SAME NOMINAL SIZE CAN HAVE DIFFERENT ACTUAL DIMENSIONS. FOR THIS DESIGN, THE 1" TA FILTER HAD THE LARGEST ACTUAL HEIGHT AND WIDTH DIMENSIONS.
- FLANGES ARE PROVIDED AROUND THE PERIMETER OF THE FILTERS FOR DUCTWORK. THE FLAT FILTER RACK IS NOT INSULATED.
- THERE IS A CUTOUT ON THE DOOR TO AVOID LUG SCREW HEADS.
- A THUMB SCREW IS USED ON THE TOP AND BOTTOM OF THE DOOR FOR REGULAR FILTER ACCESS.
- BLOCKOFFS SLIDE INTO THE FILTER TRACKS TO PREVENT AIR BYPASS AND ARE DESIGNED TO SIT IN THE TRACK WITHOUT FASTENERS.
- THE FLAT FILTER RACK IS MODELED AFTER THE UCCA DESIGN. FOR BCXE, THE DESIGN WAS SIMPLIFIED BY COMBINING THE TOP AND SIDE CHANNELS INTO ONE PART, USING ONE VERTICAL SUPPORT ON THE DOOR SIDE, AND LOW PROFILE SCREWS IN PLACE OF RIVETS FOR SECURING THE FILTER TRACKS. LOW PROFILE SCREWS GIVE THE FACTORY THE OPTION TO REWORK THE ASSEMBLY IF PARTS ARE PUT TOGETHER INCORRECTLY.
- DO NOT COVER HINGE SLOTS. DO NOT COVER CLIP HOLES FOR CAPTIVE FASTENERS.

2" Filter-SIZE 24/54/90/120  
 4" Filter-SIZE 24/36/54/90/120

1" Filter-SIZE 24/36/72  
 2" Filter-SIZE 36/72  
 4" Filter-SIZE 72

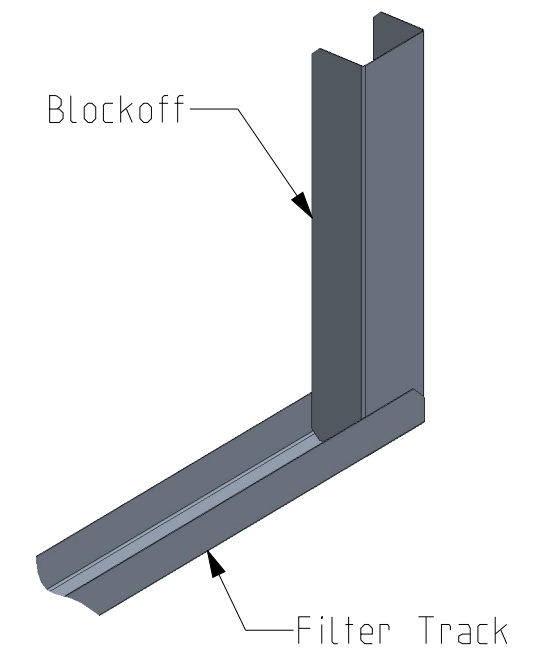
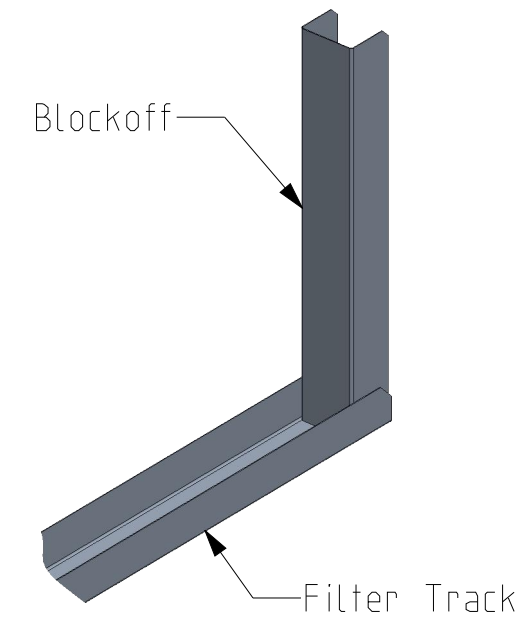

Filter Track Fasteners

SCREW; 10-32X.594, TORX PAN HEAD (HABU)

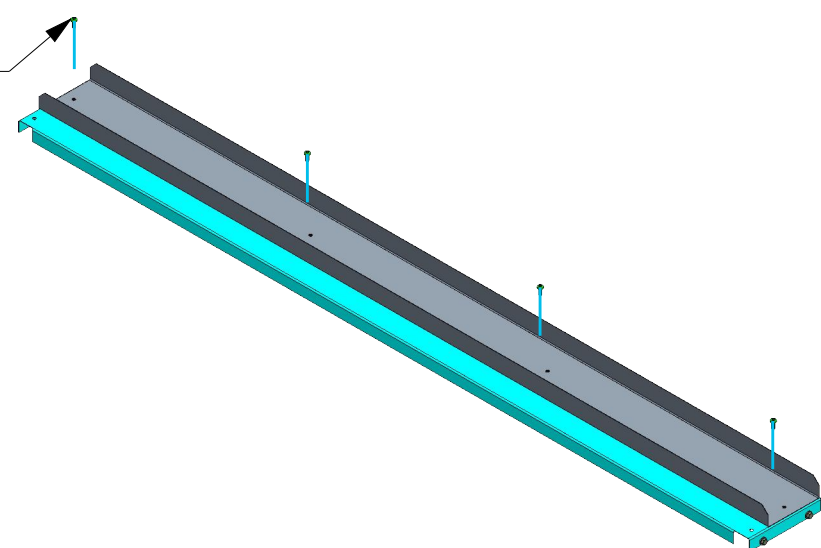

Tool-less Fastener for Door

SCREW; 0.250 X 0.625 CAPTIVE FASTENER (HRU)  
 RETAINER; CAPTIVE FASTENER, 0.250 SCRE (HRV)  
 RECEPTACLE; CAPTIVE FASTENER, CLIP-ON (HRW)

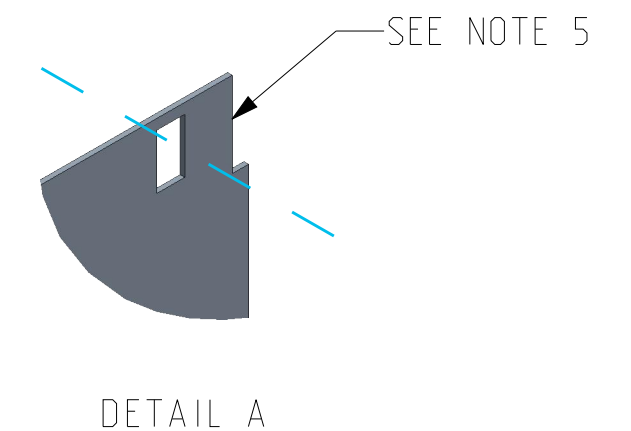
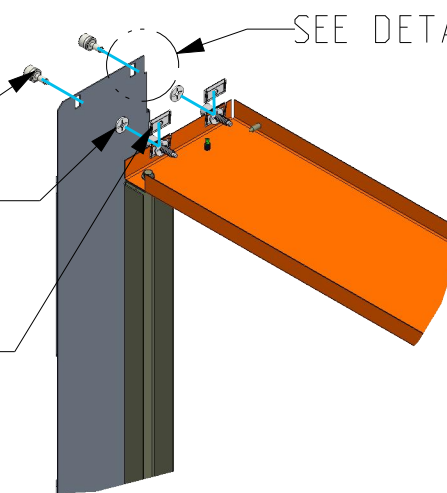

1" & 2" Filter Rack

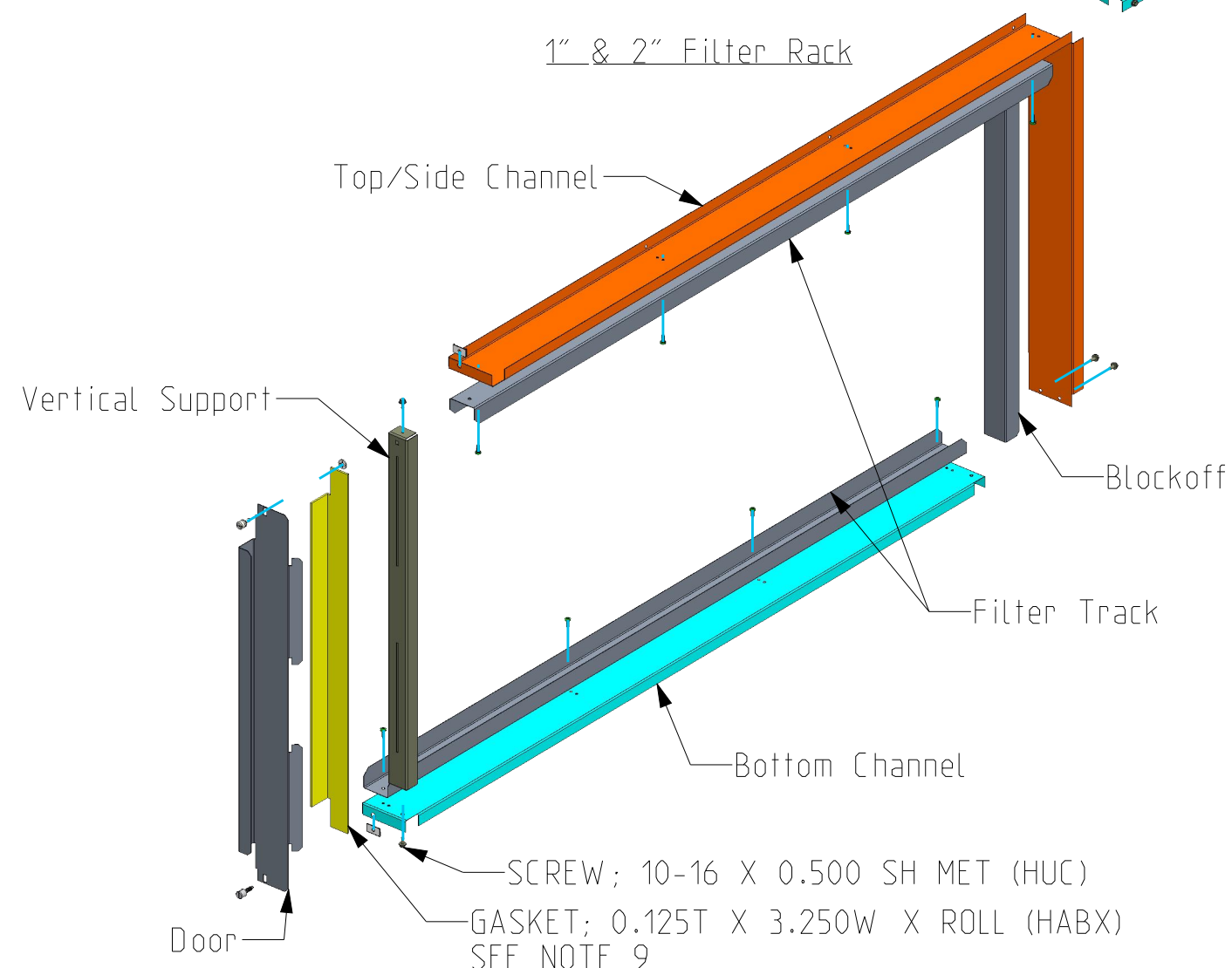

2 x 2" Combo Filter Rack

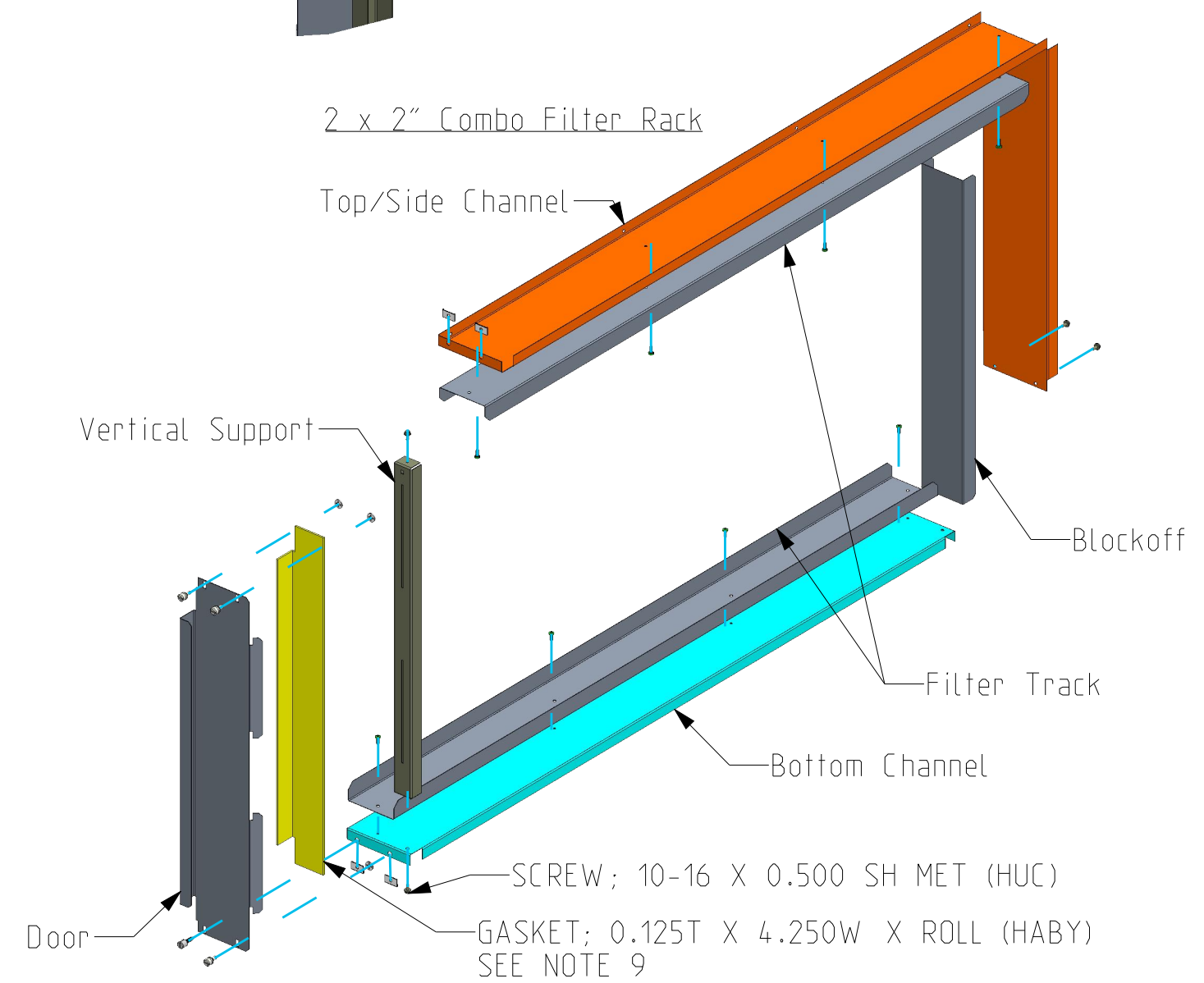

DRAWING	REVISION	VERSION
D	D	4

UNLESS OTHERWISE SPECIFIED ALL DIMENSIONS ARE IN INCHES. TOLERANCE:

.X =± 0.0  
 .XX =± 0.00  
 .XXX =± 0.000

FINISH ✓

ANGLES =± 0.0 ° HOLE DIA = :  
 CONFORMS TO ASME Y14.5M-1994.

TRANE

THIS DRAWING IS PROPRIETARY AND SHALL NOT BE COPIED OR ITS CONTENTS DISCLOSED TO OUTSIDE PARTIES WITHOUT THE WRITTEN CONSENT OF TRANE

DRAWN BY: NISARGA S ©TRANE DATE: 06-MAR-2025

DO NOT SCALE PRINT

THIRD ANGLE PROJECTION



S65380476

SHEET 4 OF 7 REV D

DESIGN INTENT  
 FLAT FILTER AVAILABILITY & INSTL

BCXE USIZ 12-120

# SIDE LOAD FILTER RACK INSTALL

NOTE(S):

1. THE FLAT FILTER RACK IS FASTENED ON THE COIL END OF THE UNIT.

Size 120 BCHE with Flat Filter

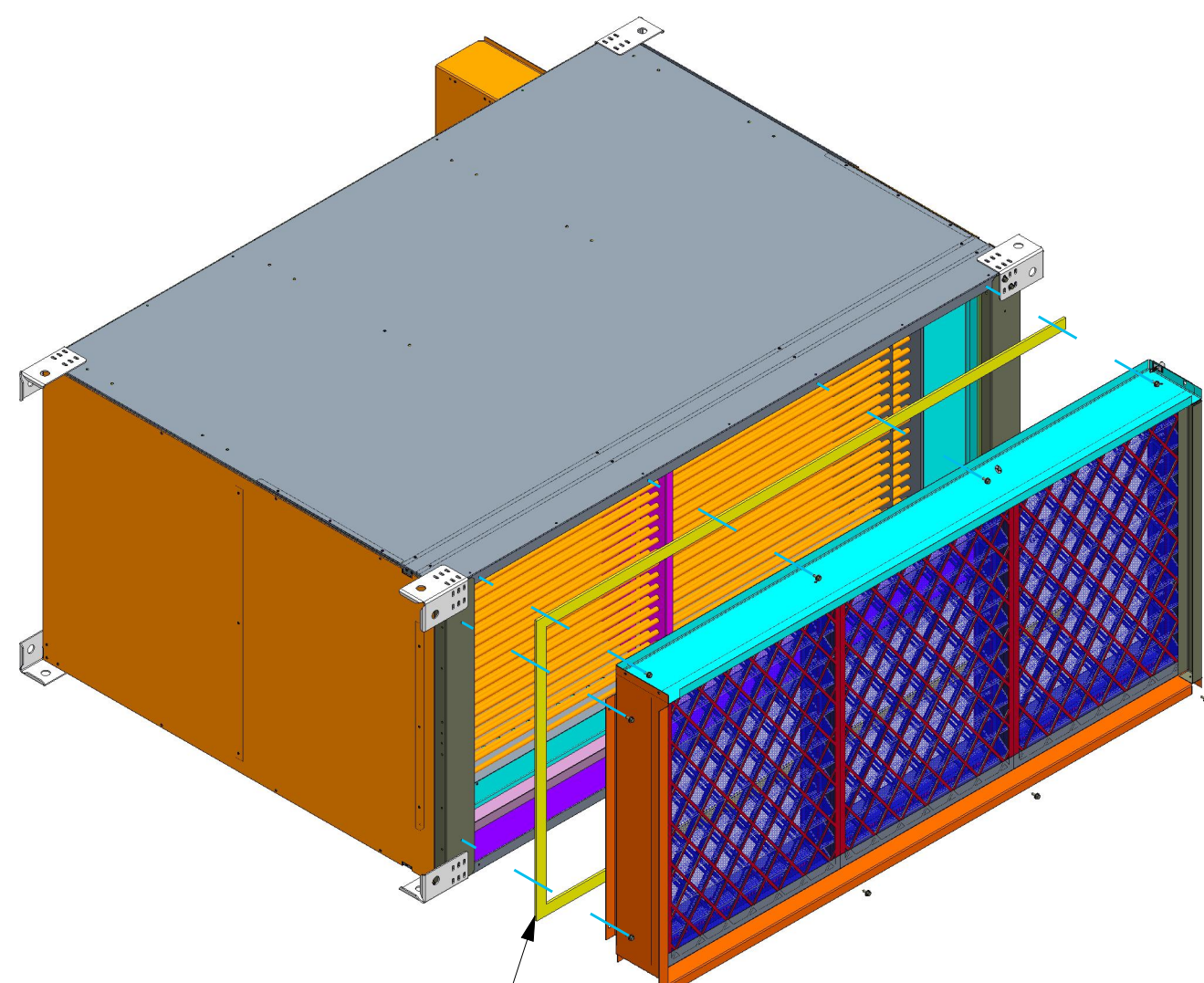

GASKET; 0.12T X 0.50W X ROLL (HABZ)

SCREW; 10-16 X 0.500 SH MET (HUC)

Size 120 BCVE with Flat Filter

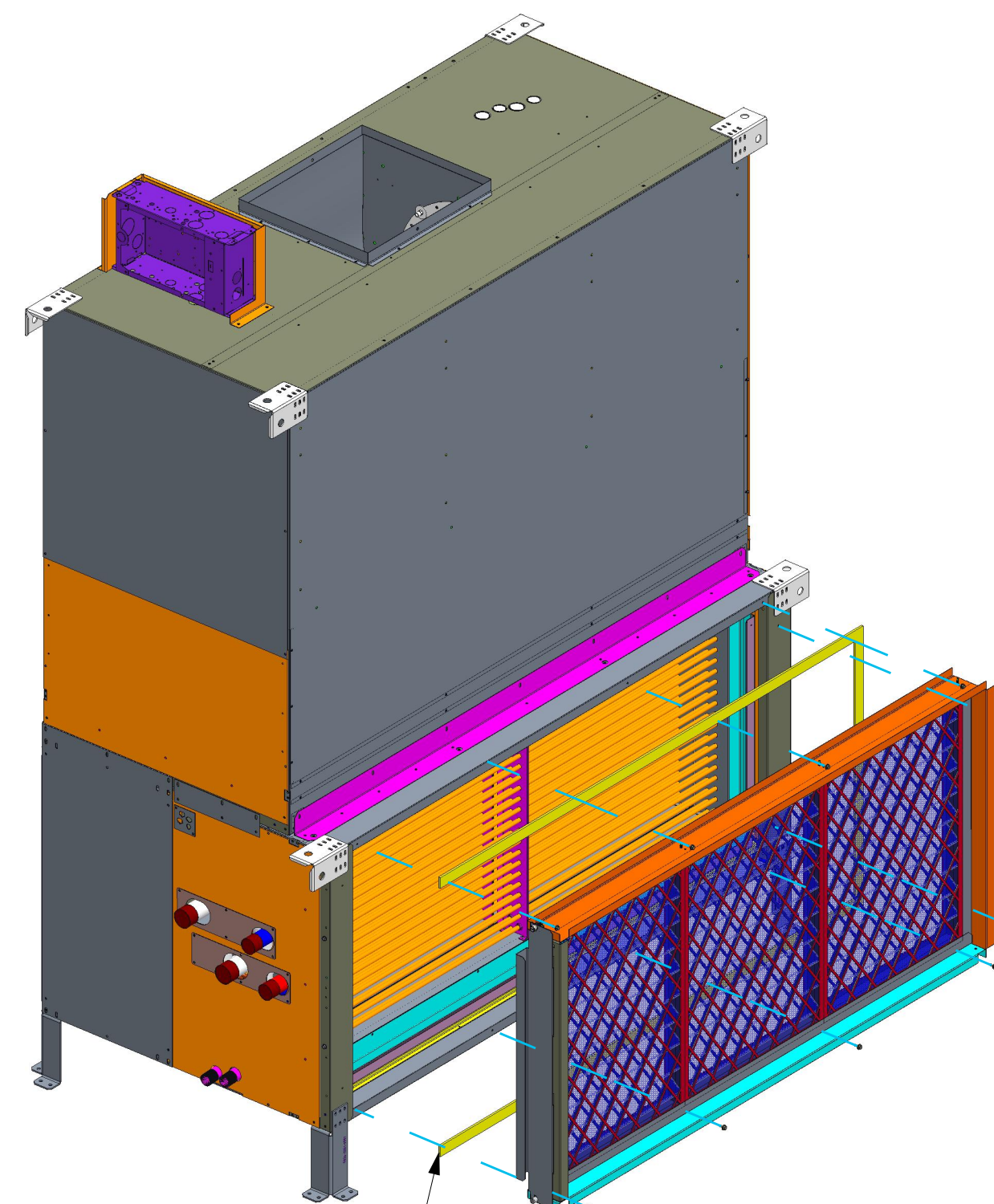

GASKET; 0.12T X 0.50W X ROLL (HABZ)

SCREW; 10-16 X 0.500 SH MET (HUC)

REVISION	VERSION
D	4

UNLESS OTHERWISE SPECIFIED ALL DIMENSIONS ARE IN INCHES. TOLERANCE:

.X =± 0.0  
 .XX =± 0.00  
 .XXX =± 0.000  
 FINISH ✓  
 ANGLES =± 0.0 ° HOLE DIA = :  
 CONFORMS TO ASME Y14.5M-1994.

TRANE

THIS DRAWING IS PROPRIETARY AND SHALL NOT BE COPIED OR ITS CONTENTS DISCLOSED TO OUTSIDE PARTIES WITHOUT THE WRITTEN CONSENT OF TRANE

DRAWN BY: NISARGA S ©TRANE DATE: 06-MAR-2025

DO NOT SCALE PRINT

THIRD ANGLE PROJECTION

S65380476

SHEET 5 OF 7 REV D

DESIGN INTENT  
 FLAT FILTER AVAILABILITY & INSTL

BCXE USIZ 12-120

# TOP/BOTTOM ACCESS FILTER TRACK ASSEMBLY

- NOTE(S):
1. THE TOP/BOTTOM ACCESS FILTER BOX SPANS THE FULL WIDTH AND HEIGHT OF THE UNIT AND CAN BE SINGLE OR DOUBLE WALL.
  2. THE TOP/BOTTOM ACCESS FILTER HAS 2" MERV 8 AND MERV 13 FILTER OPTIONS.  
 THE SAME NOMINAL FILTER SIZES ARE USED FOR FLAT FILTERS AND BOTTOM ACCESS FILTERS.
  3. SETS OF EXTRA FILTERS CAN BE ORDERED WITH THE FILTER RACK.
  4. FILTERS SLIDE UP INTO THE TOP FILTER TRACK VIA SIDE BLOCKOFFS AND SIT UP AGAINST BOTTOM CHANNEL.  
 ANGLE SECURED TO DOOR KEEPS FILTERS FROM SLIPPING BACKWARDS WHEN THE DOOR IS CLOSED.
  5. LOW PROFILE SCREWS ARE USED IN FILTER TRACKS SO FILTER CAN EASILY SLIDE OVER THE TOP OF THE SCREW HEAD AND CAN BE EASILY REMOVED IF PARTS ARE ASSEMBLED INCORRECTLY.
  6. A HINGED DOOR IS PROVIDED FOR REGULAR ACCESS TO FILTERS  
 AND IS SECURED OPPOSITE THE HINGE WITH A SCREW AND SPEED NUT.
  7. THE TOP/BOTTOM ACCESS FILTER BOX SHIPS SEPARATE FROM THE UNIT AND IS FIELD INSTALLED  
 VIA BOLTING STRIPS ON ALL FOUR SIDES WHERE BOLTING STRIPS THAT ARE CUT SCREWED INTO THE UNIT PANELS.
  8. THE AIR ENTERING AND AIR EXITING SIDE OF THE BOTTOM ACCESS FILTER ARE COVERED IN LEED WRAP, SEE DESIGN INTENT S65380473.
  9. CUSTOMERS CAN ROTATE THE BOTTOM ACCESS FILTER MODULE 180 DEGREES AND MAKE IT TOP ACCESS IF DESIRED.
  10. SEE PAGE 6 FOR PANEL ASSEMBLY.

Size 120 BCXE Double Wall Bottom Access Filter Exploded View

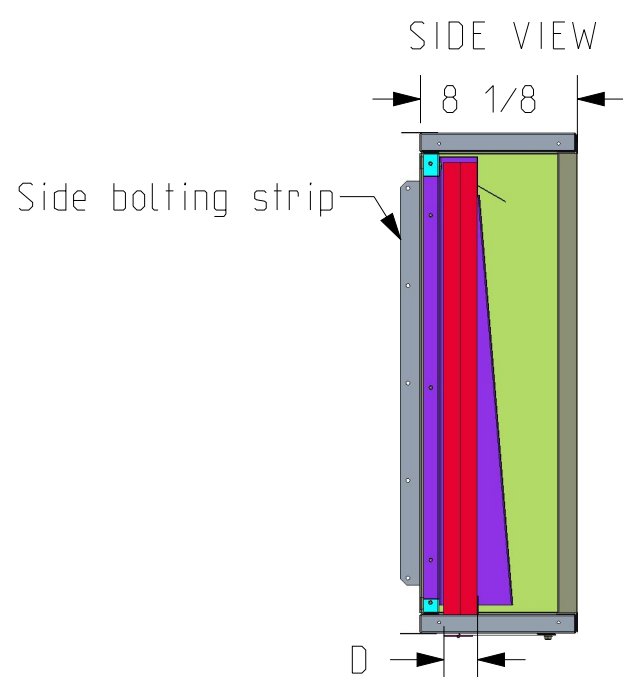
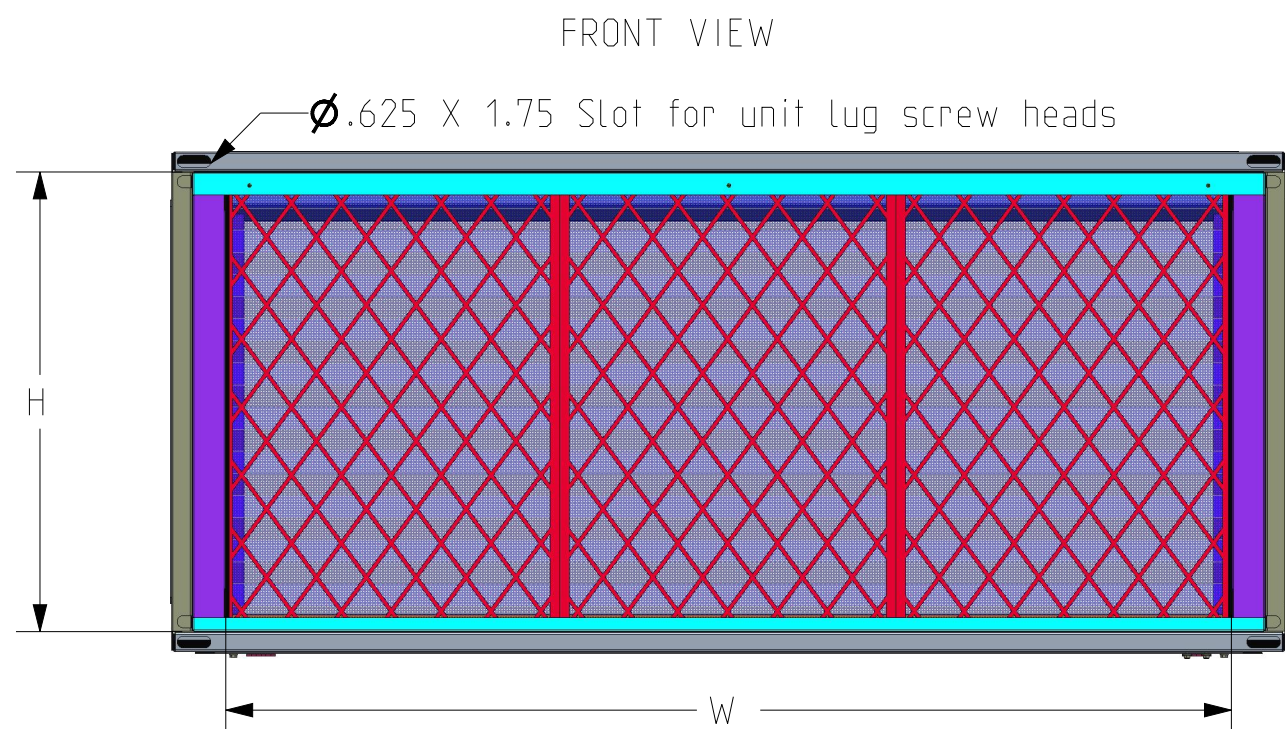
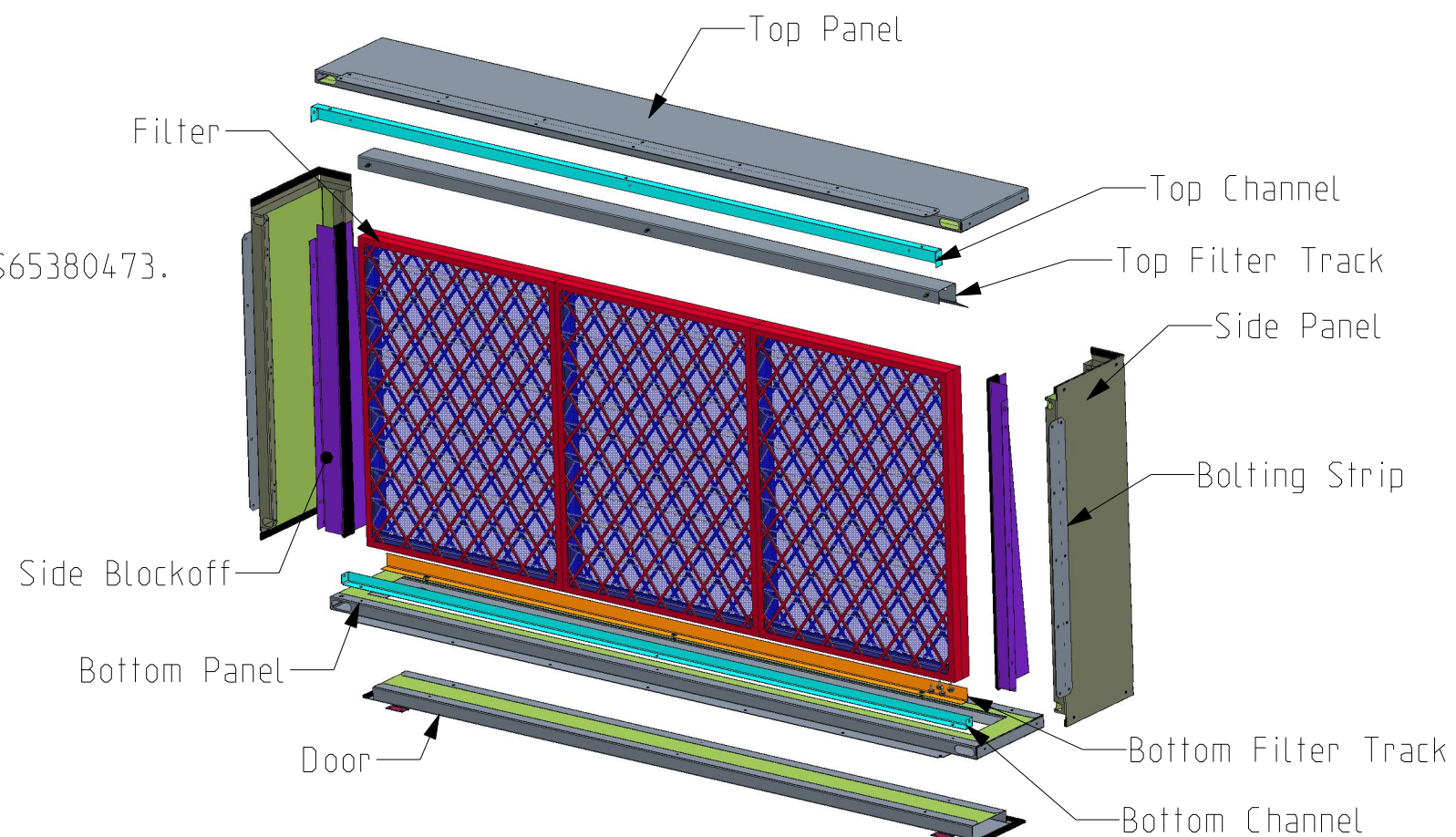

D = Actual Filter Depth + 0.0625 + Max Screw Head Height

W = (Actual Filter1 Width) + (Actual Filter2 Width) + (Actual Filter3 Width) + (0.125 x Filter Qty)  
 H = Actual Filter Height + 0.125 + 2\*(Screw Head Max Height)

Low Profile Screw Installation

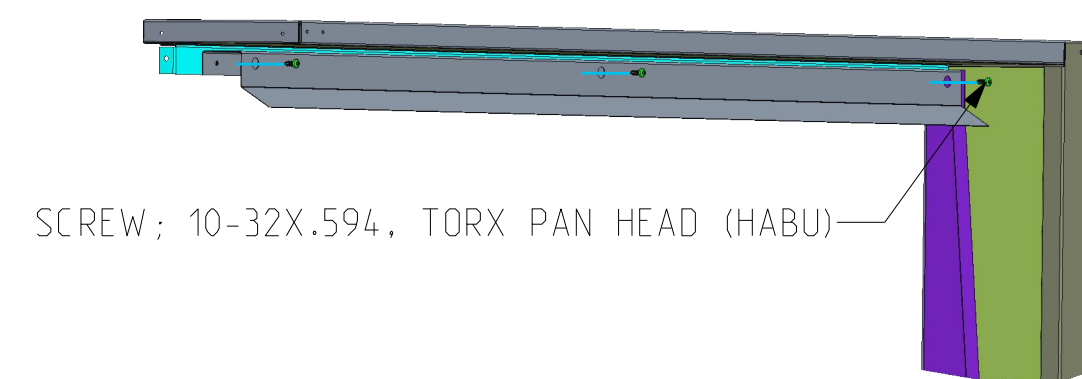

SCREW; 10-32X.594, TORX PAN HEAD (HABU)

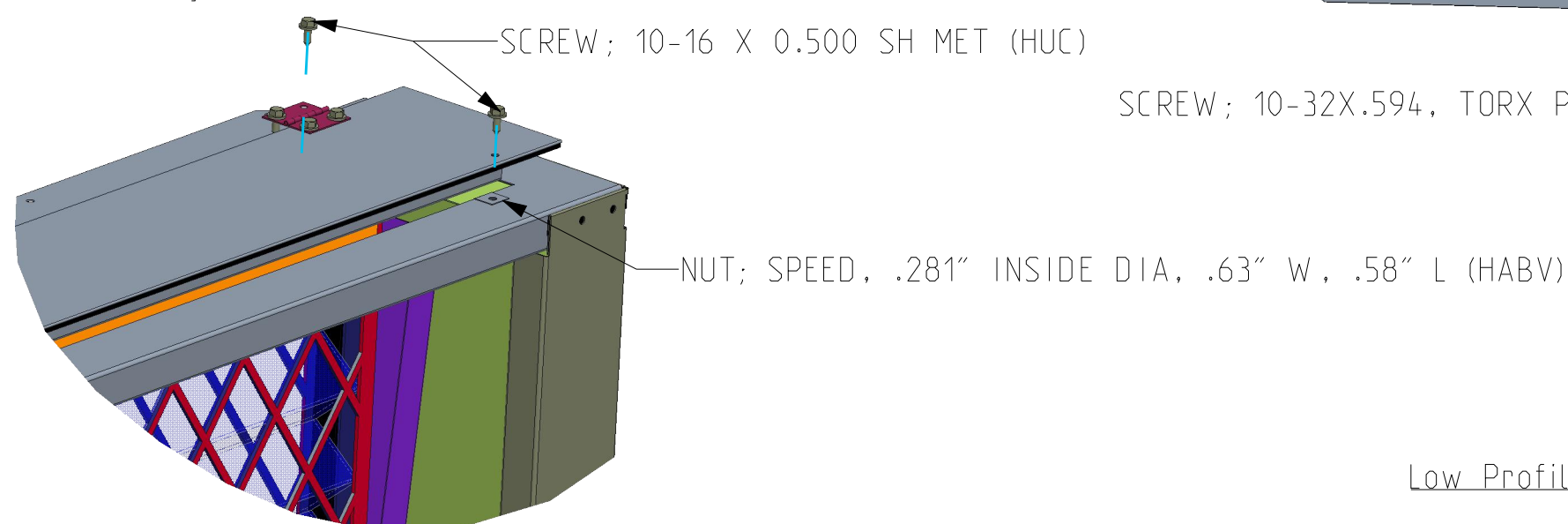
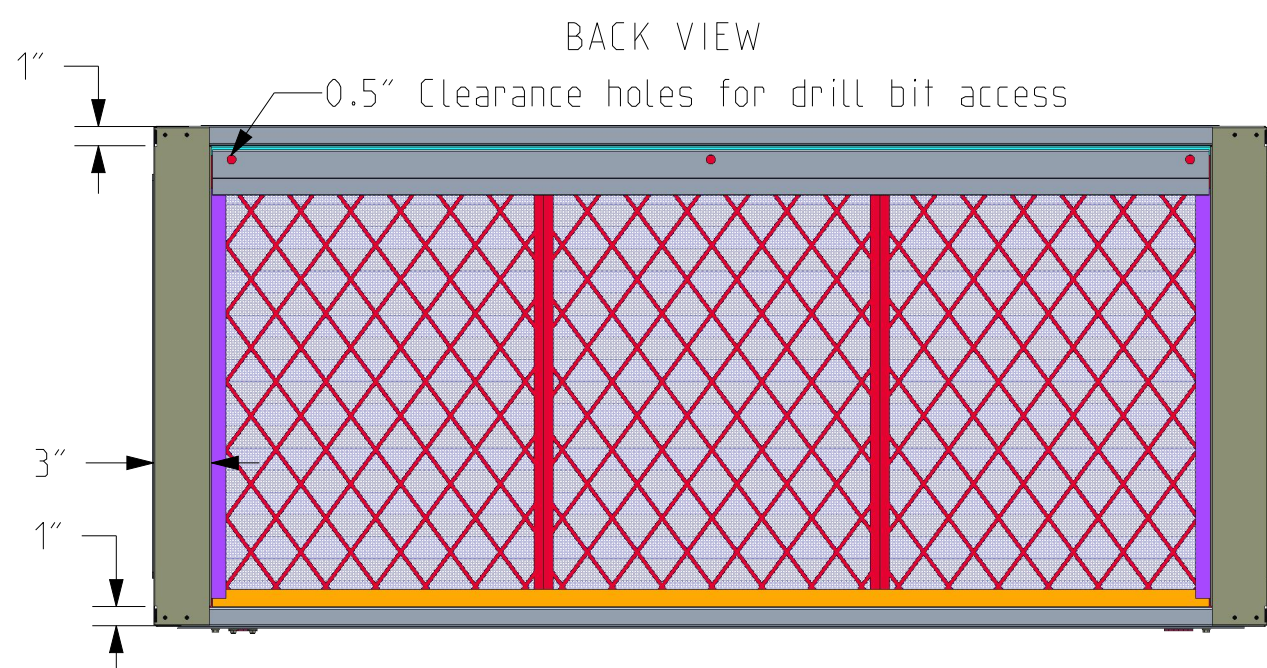

Low Profile Screw Installation

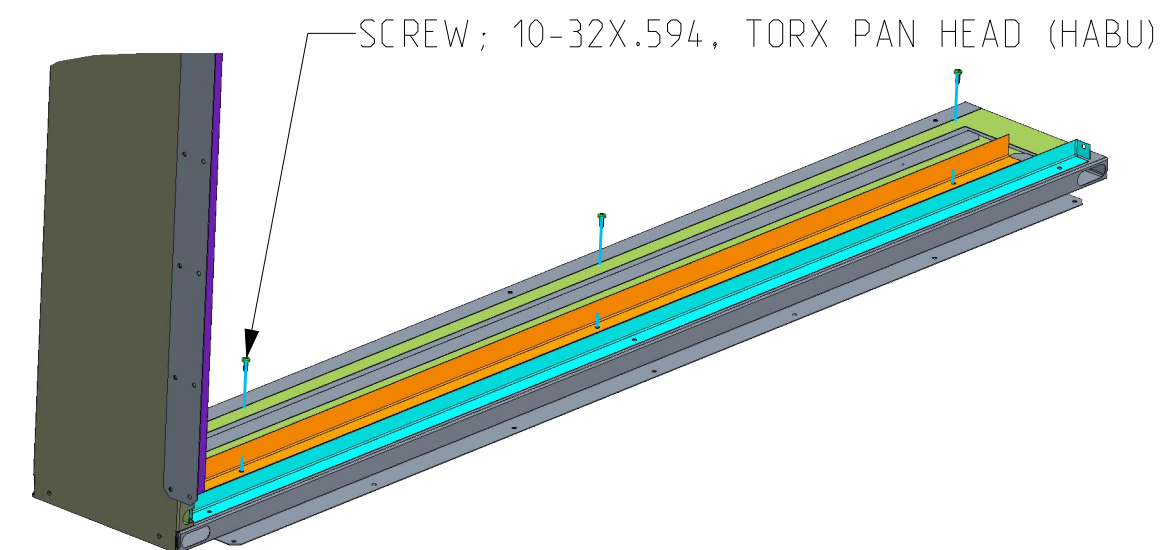

SCREW; 10-32X.594, TORX PAN HEAD (HABU)

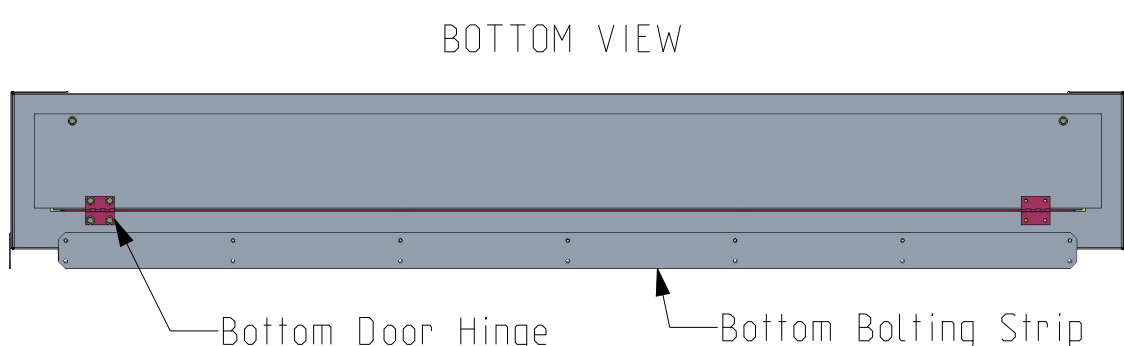
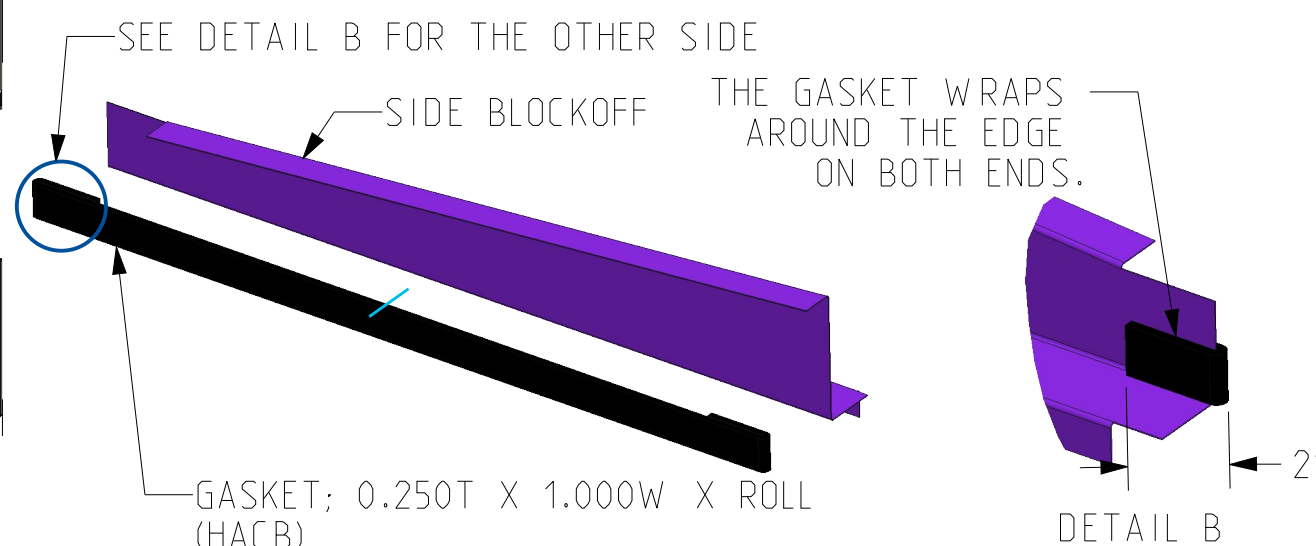

4

3

2

1

REVISION	VERSION
D	4

UNLESS OTHERWISE SPECIFIED ALL DIMENSIONS ARE IN INCHES. TOLERANCE:

.X =± 0.0  
 .XX =± 0.00  
 .XXX =± 0.000

FINISH ✓

ANGLES =± 0.0 ° HOLE DIA = :  
 CONFORMS TO ASME Y14.5M-1994.

TRANE

THIS DRAWING IS PROPRIETARY AND SHALL NOT BE COPIED OR ITS CONTENTS DISCLOSED TO OUTSIDE PARTIES WITHOUT THE WRITTEN CONSENT OF TRANE

DRAWN BY: NISARGA S TRANE DATE: 06-MAR-2025

DO NOT SCALE PRINT

THIRD ANGLE PROJECTION

S65380476

SHEET 6 OF 7 REV D

DESIGN INTENT  
 FLAT FILTER AVAILABILITY & INSTL

BCXE USIZ 12-120

# PANEL ASSEMBLY

NOTE(S):  
 1. SEE S65380468 FOR INSULATION DESIGN INTENT.

Side Panel Assembly

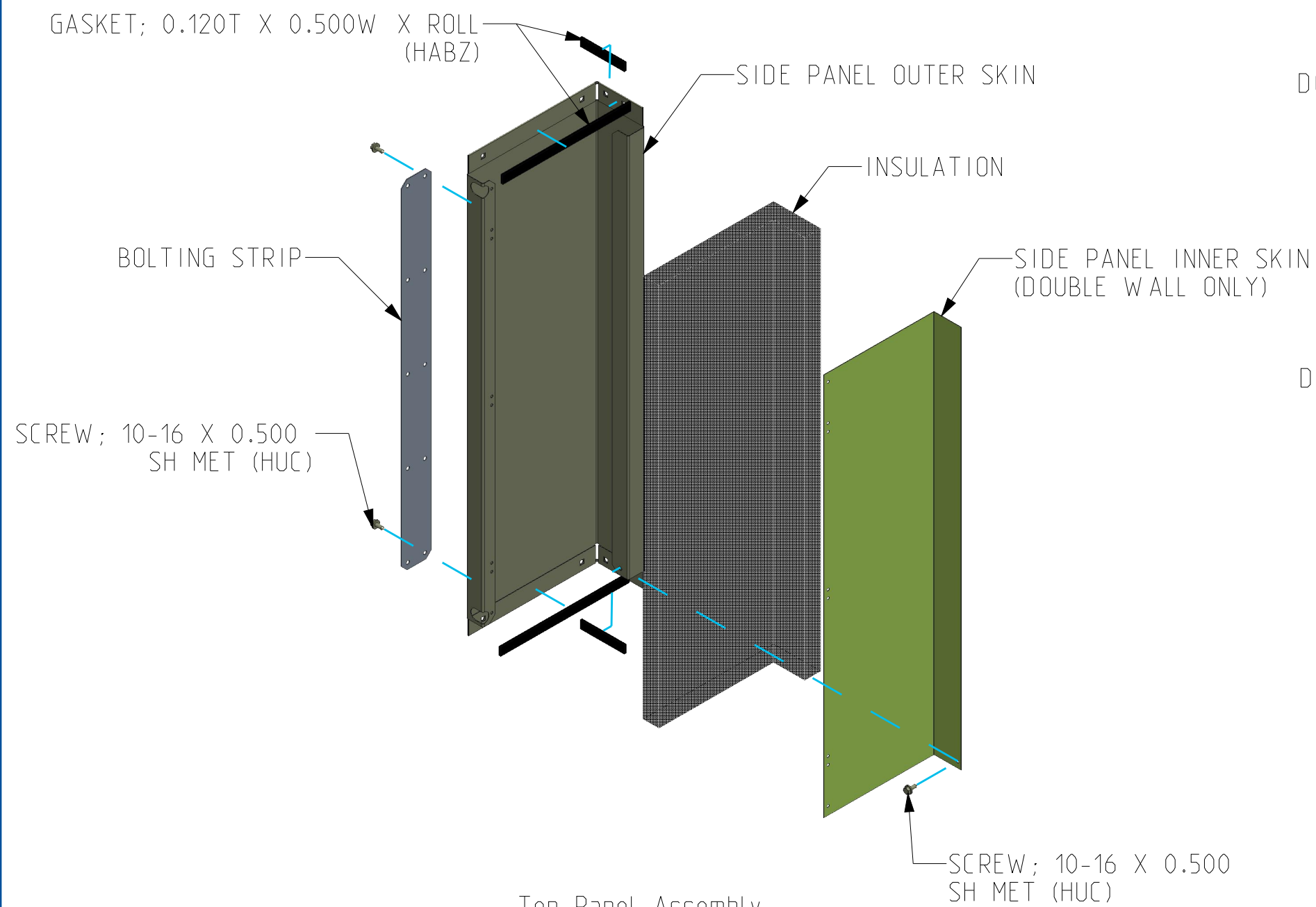

Door Panel Assembly

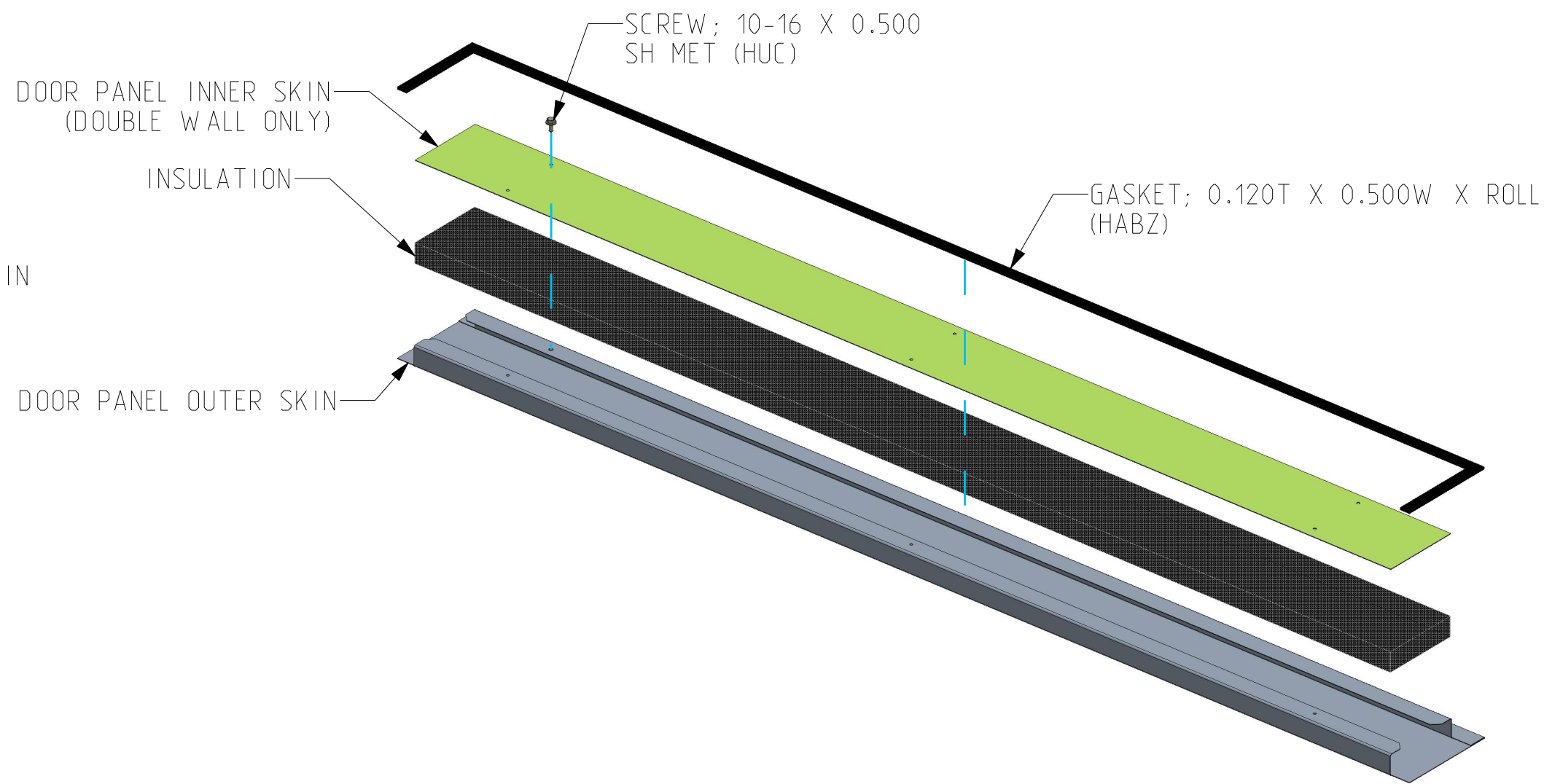

Top Panel Assembly

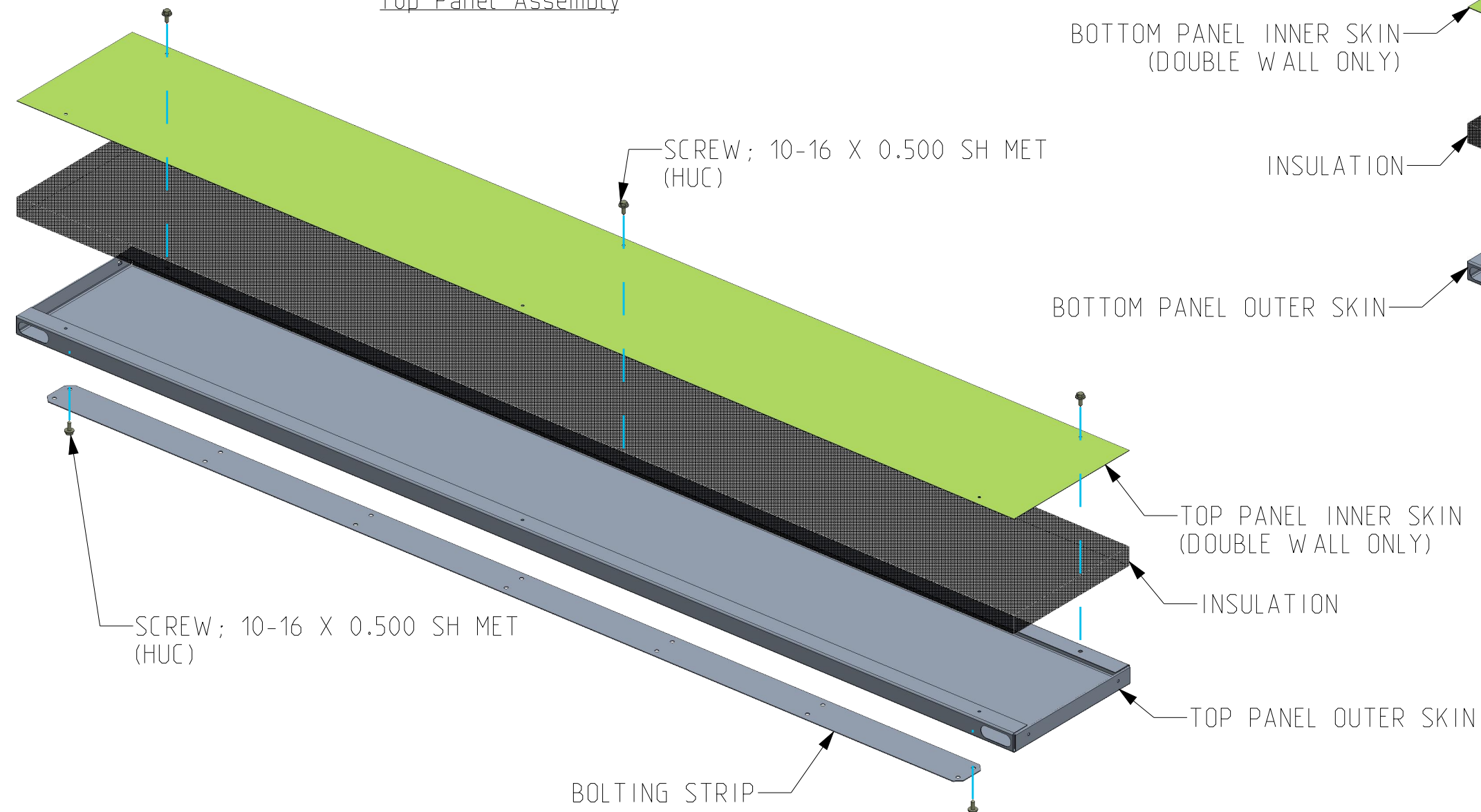

Bottom Panel Assembly

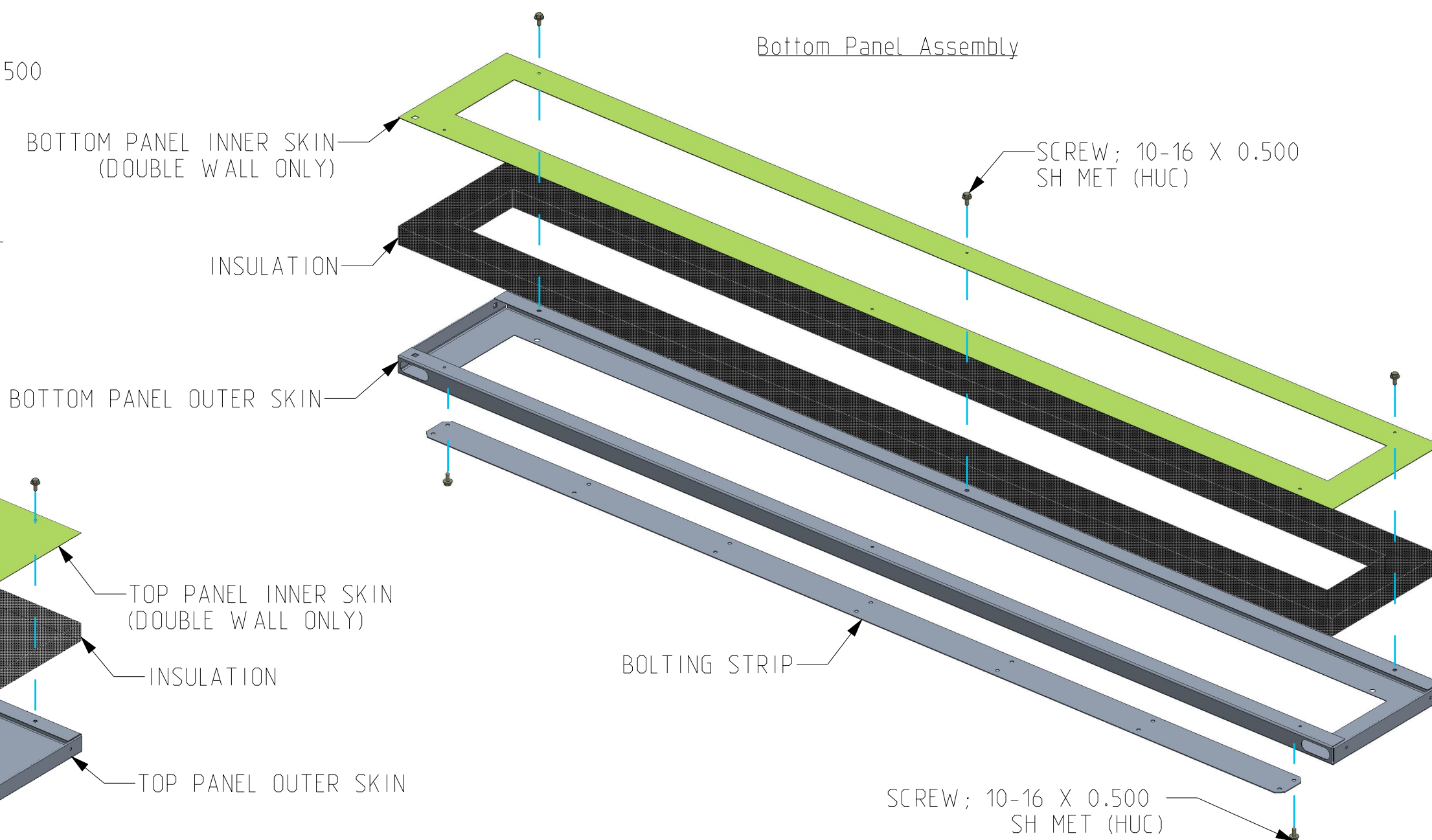

4

3

2

1

	REVISION	VERSION
DRAWING	D	4

UNLESS OTHERWISE SPECIFIED ALL DIMENSIONS ARE IN INCHES. TOLERANCE:

.X =± 0.0  
 .XX =± 0.00  
 .XXX =± 0.000

FINISH ✓

ANGLES =± 0.0 ° HOLE DIA = ∴  
 CONFORMS TO ASME Y14.5M-1994.

TRANE

THIS DRAWING IS PROPRIETARY AND SHALL NOT BE COPIED OR ITS CONTENTS DISCLOSED TO OUTSIDE PARTIES WITHOUT THE WRITTEN CONSENT OF TRANE

DRAWN BY: NISARGA S ©TRANE DATE: 06-MAR-2025

DO NOT SCALE PRINT

THIRD ANGLE PROJECTION

S65380476

SHEET 7 OF 7 REV D

DESIGN INTENT  
 FLAT FILTER AVAILABILITY & INSTL

BCXE USIZ 12-120

# TOP/BOTTOM ACCESS FILTER INSTALL

NOTE(S):

1. TOP/BOTTOM ACCESS FILTER BOXES SHIP SEPARATE FROM THE MAIN UNIT.
2. ATTACH TOP/BOTTOM ACCESS FILTER BOX TO UNIT WITH SCREWS INTO THE BOLTING STRIPS ON ALL FOUR SIDES OF THE UNIT.
3. ALL BOLTING STRIP SCREWS REQUIRED FOR SEISMIC INSTALLATIONS.

Screw Qty		
Unit Size	Top/Bottom Bolting Strip	Side Bolting Strip
12	4	3
18	4	3
24	4	3
36	6	3
54	6	3
72	7	3
90	6	5
120	7	5

Size 120 BCHE with Bottom Access Filter

Size 120 BCVE with Top Access Filter

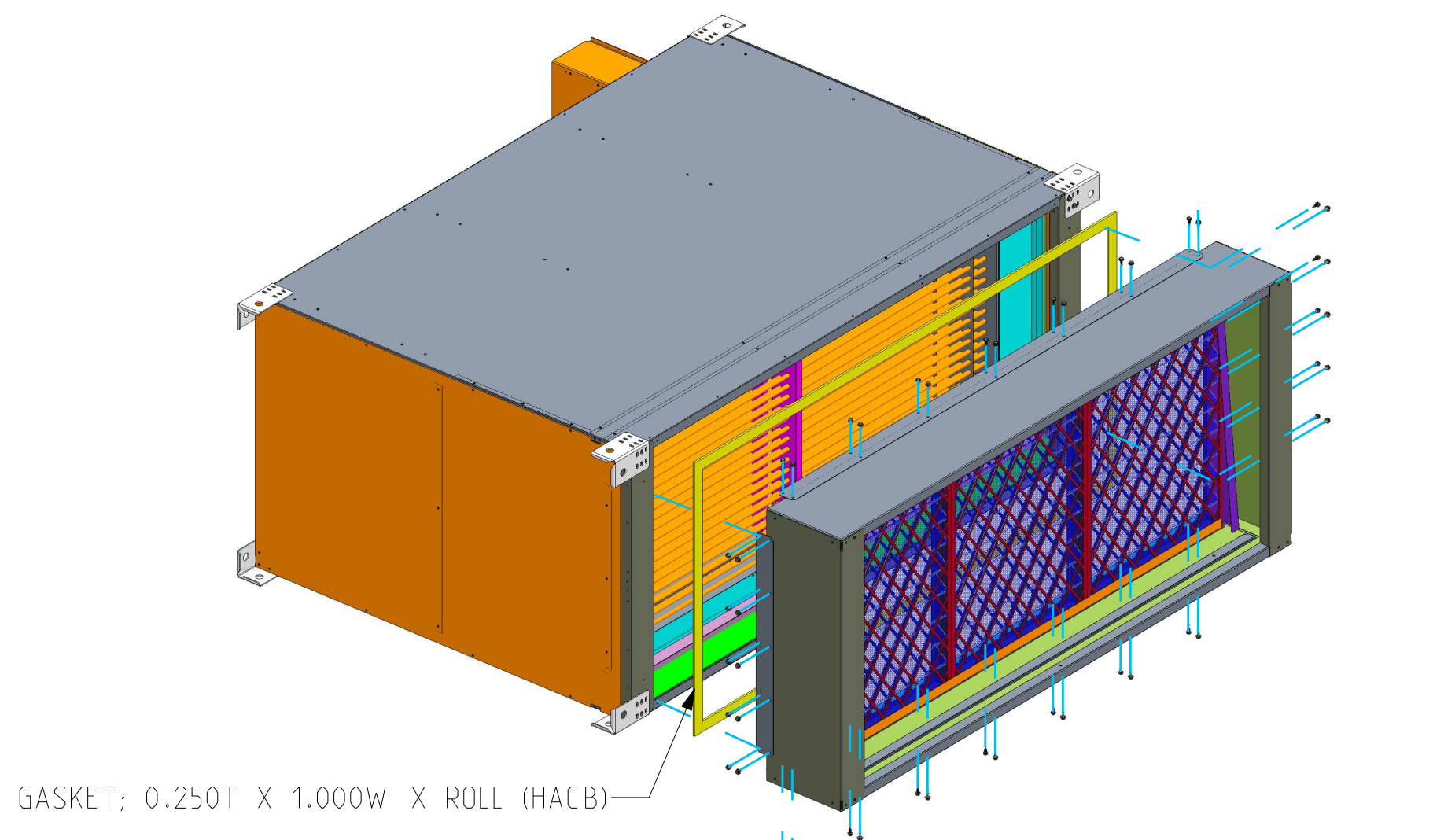

GASKET; 0.250T X 1.000W X ROLL (HACB)

SCREW SELF-DRILLING,  
 #10-16 X 1/2 HEX WASHER (HABP)

SCREW; 10-16 X 0.500 SH MET (HUC)

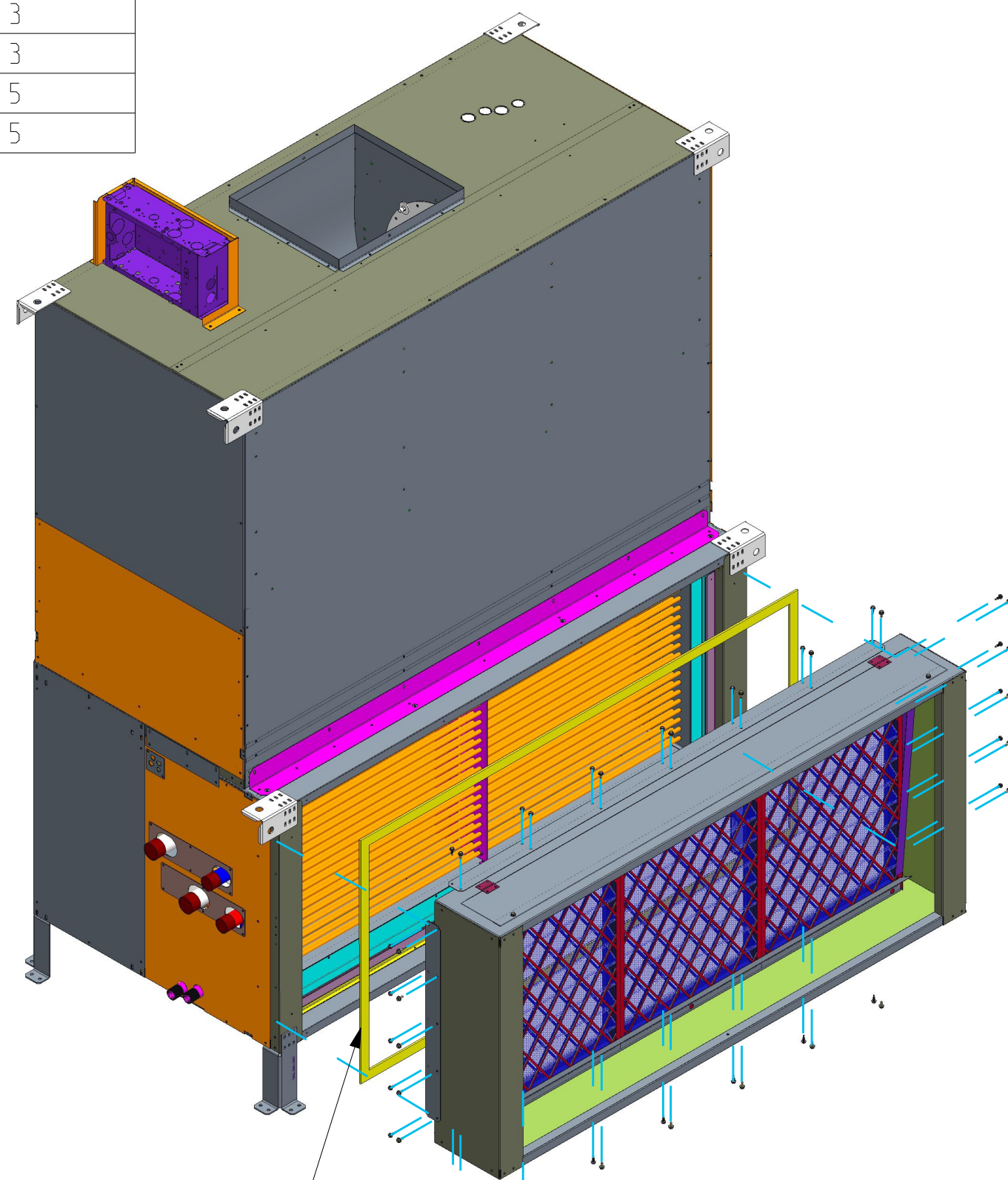

GASKET; 0.250T X 1.000W X ROLL (HACB)

SCREW SELF-DRILLING,  
 #10-16 X 1/2 HEX WASHER (HABP)

SCREW; 10-16 X 0.500 SH MET (HUC)