

Installation Instructions

Combustion Blower Motor Wiring Kit Gas Heat

SAFETY WARNING

Only qualified personnel should install and service the equipment. The installation, starting up, and servicing of heating, ventilating, and air-conditioning equipment can be hazardous and requires specific knowledge and training. Improperly installed, adjusted or altered equipment by an unqualified person could result in death or serious injury. When working on the equipment, observe all precautions in the literature and on the tags, stickers, and labels that are attached to the equipment.

Warnings, Cautions and Notices

Warnings, Cautions and Notices. Note that warnings, cautions and notices appear at appropriate intervals throughout this manual. Warnings are provided to alert installing contractors to potential hazards that could result in personal injury or death. Cautions are designed to alert personnel to hazardous situations that could result in personal injury, while notices indicate a situation that could result in equipment or property-damage-only accidents.

Your personal safety and the proper operation of this machine depend upon the strict observance of these precautions.

ATTENTION: Warnings, Cautions and Notices appear at appropriate sections throughout this literature. Read these carefully.

 **WARNING:** Indicates a potentially hazardous situation which, if not avoided, could result in death or serious injury.

 **CAUTION:** Indicates a potentially hazardous situation which, if not avoided, could result in minor or moderate injury. It could also be used to alert against unsafe practices.

NOTICE: Indicates a situation that could result in equipment or property-damage-only accidents.

Important Environmental Concerns!

Scientific research has shown that certain man-made chemicals can affect the earth's naturally occurring stratospheric ozone layer when released to the atmosphere. In particular, several of the identified chemicals that may affect the ozone layer are refrigerants that contain Chlorine, Fluorine and Carbon (CFCs) and those containing Hydrogen, Chlorine, Fluorine and Carbon (HCFCs). Not all refrigerants containing these compounds have the same potential impact to the environment. Trane advocates the responsible handling of all refrigerants-including industry replacements for CFCs such as HCFCs and HFCs.

Responsible Refrigerant Practices!

Trane believes that responsible refrigerant practices are important to the environment, our customers, and the air conditioning industry. All technicians who handle refrigerants must be certified. The Federal Clean Air Act (Section 608) sets forth the requirements for handling, reclaiming, recovering and recycling of certain refrigerants and the equipment that is used in these service procedures. In addition, some states or municipalities may have additional requirements that must also be adhered to for responsible management of refrigerants. Know the applicable laws and follow them.

WARNING

Hazardous Voltage w/Capacitors!

Disconnect all electric power, including remote disconnects and discharge all motor start/run capacitors before servicing. Follow proper lockout/tagout procedures to ensure the power cannot be inadvertently energized. Verify with an appropriate voltmeter that all capacitors have discharged. Failure to disconnect power and discharge capacitors before servicing could result in death or serious injury.

Note: For additional information regarding the safe discharge of capacitors, see *PROD-SVB06A-EN* or *PROD-SVB06A-FR*

⚠ WARNING

Proper Field Wiring and Grounding Required!

All field wiring **MUST** be performed by qualified personnel. Improperly installed and grounded field wiring poses **FIRE** and **ELECTROCUTION** hazards. To avoid these hazards, you **MUST** follow requirements for field wiring installation and grounding as described in **NEC** and your local/state electrical codes. Failure to follow codes could result in death or serious injury.

⚠ WARNING

Personal Protective Equipment (PPE) Required!

Installing/servicing this unit could result in exposure to electrical, mechanical and chemical hazards.

- Before installing/servicing this unit, technicians **MUST** put on all Personal Protective Equipment (PPE) recommended for the work being undertaken. **ALWAYS** refer to appropriate MSDS and OSHA guidelines for proper PPE.
- When working with or around hazardous chemicals, **ALWAYS** refer to appropriate MSDS and OSHA guidelines for information on allowable personal exposure levels, proper respiratory protection and handling recommendations.
- If there is a risk of arc or flash, technicians **MUST** put on all Personal Protective Equipment (PPE) in accordance with **NFPA70E** or other country-specific requirements for arc/flash protection **PRIOR** to servicing the unit.

Failure to follow recommendations could result in death or serious injury.

Combustion Blower Motor Wire Harness

Installation Instructions for Staged Gas Heat

Wiring Kit Contents (KIT15855)

- Contactor (CFR)
- Wire Harness
- Screws (2)
- Wire Ties
- Installers Guide
- Wire Diagram

All Staged Gas Units

WARNING

Proper Field Wiring and Grounding Required!

All field wiring **MUST** be performed by qualified personnel. Improperly installed and grounded field wiring poses **FIRE** and **ELECTROCUTION** hazards. To avoid these hazards, you **MUST** follow requirements for field wiring installation and grounding as described in **NEC** and your local/state electrical codes. Failure to follow codes could result in death or serious injury.

WARNING

Hazardous Voltage w/Capacitors!

Disconnect all electric power, including remote disconnects and discharge all motor start/run capacitors before servicing. Follow proper lockout/tagout procedures to ensure the power cannot be inadvertently energized. Verify with an appropriate voltmeter that all capacitors have discharged. Failure to disconnect power and discharge capacitors before servicing could result in death or serious injury.

*For additional information regarding the safe discharge of capacitors, see **PROD-SVB06A-EN** or **PROD-SVB06A-FR***

1. Secure power to the unit using proper lock out/tag out procedures.
2. Remove the panel covering the combustion blower motor compartment.
3. Locate and install the CFR contactor. Refer to [Figure 1, p. 6](#) for Voyager III contactor location and [Figure 3, p. 7](#) for Voyager II contactor location.
4. Determine unit voltage
 - For Voyager II instructions, continue to Step 1 under the heading, Voyager II Staged Gas Units.
 - For Voyager III instructions, continue to Step 1 under the heading, Voyager III Staged Gas Units.

Voyager II Staged Gas Units

1. Locate and unplug PPF11 - Combustion Blower Motor plug.
2. Locate the ignition board and unplug 29A (OR), W36 (BK), 23D (RD).
3. For 460/575VAC Units:
 - a. On the secondary of the Ignition Transformer locate wire W14 (RD) and remove.
 - b. On the secondary of the Ignition Transformer locate wire W34 (PR), 14C (GR) and remove.
 - c. Remove Wire 14C (GR) from the Y2 terminal of the unit Ignition Transformer and isolate or remove from the unit entirely. This wire does not exist on 208-230VAC Units.

4. For 208-230VAC Units:
 - a. On the primary of the Ignition Transformer locate wire W14 (RD) and remove.
 - b. On the primary of the Ignition Transformer locate wire W34 (PR) and remove.

Voyager III Staged Gas Units

1. Locate and unplug PPF12 (and PPF11 for units with two Staged Gas Ignition Systems) - Combustion Blower Motor plug.

Important: *If the unit is a Modulating Gas Heat Unit proceed to Step 2c.*

2. For 460/575VAC Units:
 - a. On the secondary of the Ignition Transformer #1 locate wire W9 and 245C at Y2 and remove.
 - b. On the secondary of the Ignition Transformer #1 locate wire W13 and W22 at Y1 and remove.
 - c. On the secondary of the Ignition Transformer #2 locate wire W11 at Y2 and remove.
 - d. On the secondary of the Ignition Transformer #2 locate wire W15 and 237A at Y1 and remove.
 - e. Locate the Ignition Board(s) and remove wires W20, W21, W13 for IGN1 and Wires 240A, 241A and W15 for IGN2.
 - f. Remove Wire 250C and 245C from the Y2 terminal of the unit Ignition Transformer(s) and isolate or remove from the unit entirely. This wire does not exist on 208-230VAC Units.
3. For 208-230VAC Units:
 - a. On the primary of Ignition Transformer, locate wires W14 and W12 and remove.
 - b. On the primary of Ignition Transformer, locate wires W11 and W15 and remove.

All Staged Gas Units

1. Cut the wire ties and remove harness between the Ignition Transformer, Ignition Board and the Combustion Blower Motor.
2. Install the new Combustion Blower Motor Wiring Harness
3. Wire W112 to HI/Single on the Ignition Board.
4. Wire W113 to Lo on the Ignition Board.
5. Wire W110 to CBM L1 on the Ignition Board.
6. For 460/575VAC Units:
 - Wire W114 to Y1 on the Ignition Transformer.
 - Wire W118 to Y2 on the Ignition Transformer.
- For 208-230VAC Units:
 - Wire W114 to H1 on the Ignition Transformer.
 - Wire W118 to H2 for a 208VAC unit of H3 for a 230VAC unit.
7. Wire W110 and W114 to L1 on the CFR.
8. Wire W117 to terminal T1 on the CFR.
9. Wire W111 and W112 to terminal L2 on the CFR.
10. Wire W115 to terminal T2 on the CFR.
11. Control wire W113 to the CFR Coil.
12. Control wires W116 and W118 go to the other side of the CFR coil.
13. Plug the new PPM11 to PPF11 on Voyager II and PPM12 and PPF12 on Voyager III - Combustion Blower Motor plug.
14. Dress the wires using wire ties.

Combustion Blower Motor Wire Harness

15. Overlay the new wiring schematic inset provided in the kit.
16. Test the unit for proper operation.
 - a. Begin the test mode by shorting Test 1 and Test 2 until the heating mode is reached.
 - b. Sixty (60) seconds after ignition the burner firing rate is reduced to low fire. It is at this time the contactor should pull in. The contactor will not be energized in high fire.

Figure 1. Voyager III contactor location

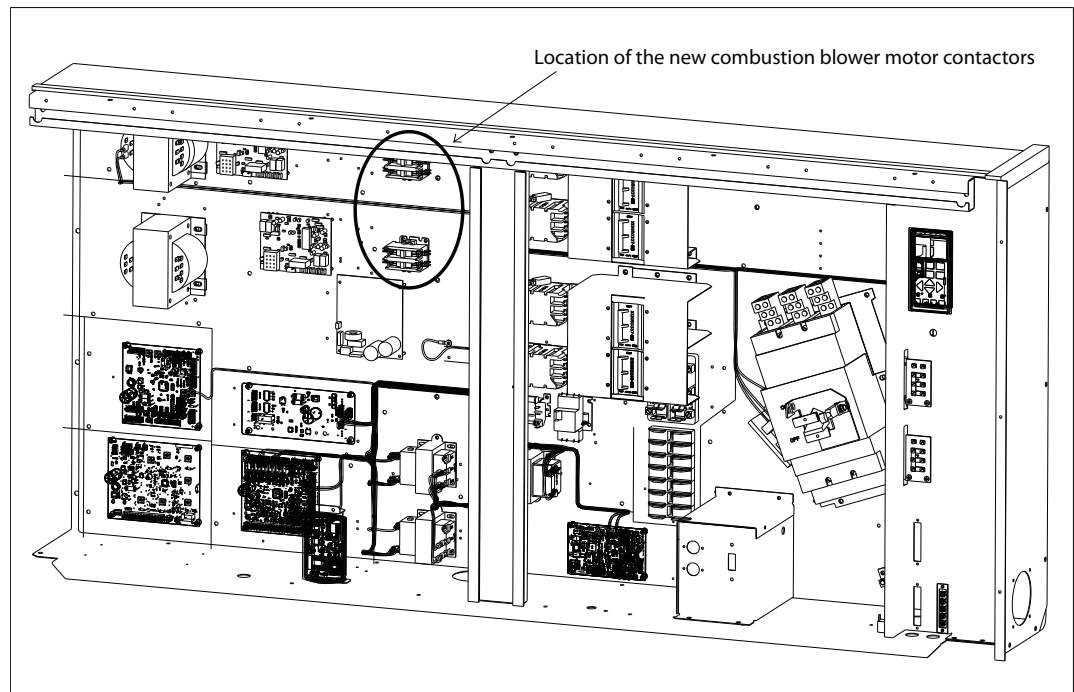

Figure 2. Combustion blower motor wiring diagram

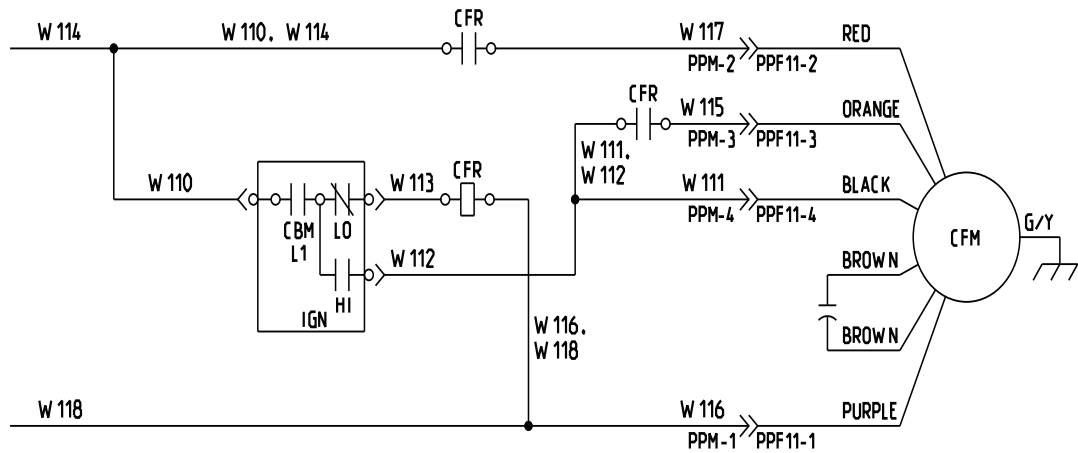
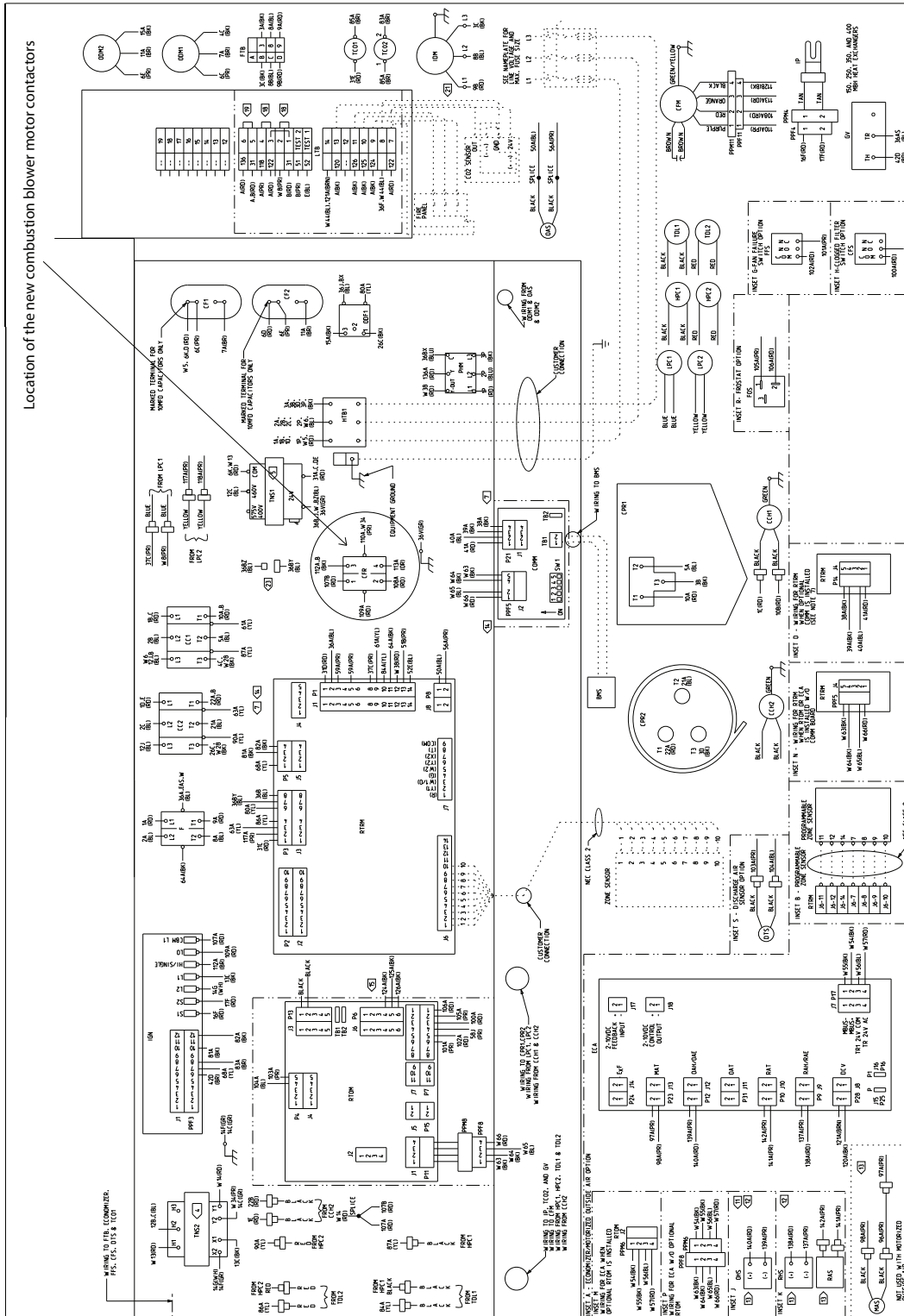

Figure 3. Voyager II contactor location



The manufacturer optimizes the performance of homes and buildings around the world. A business of Ingersoll Rand, the leader in creating and sustaining safe, comfortable and energy efficient environments, the manufacturer offers a broad portfolio of advanced controls and HVAC systems, comprehensive building services, and parts. For more information, visit www.IRCO.com.

The manufacturer has a policy of continuous product and product data improvement and reserves the right to change design and specifications without notice.

© 2011 Trane All rights reserved
RT-SVN17A-EN 15 Feb 2011
Supersedes 15 Nov 2010

Produced with paper that uses fewer trees
and chemicals, less energy, and environmentally
friendly print practices that reduce waste.

