

Application Guide

Variable Refrigerant Flow (VRF) System Sequence of Operations

SAFETY WARNING



Only qualified personnel should install and service the equipment. The installation, starting up, and servicing of heating, ventilating, and air-conditioning equipment can be hazardous and requires specific knowledge and training. Improperly installed, adjusted or altered equipment by an unqualified person could result in death or serious injury. When working on the equipment, observe all precautions in the literature and on the tags, stickers, and labels that are attached to the equipment.

Introduction

Warnings, Cautions, and Notices

Safety advisories appear throughout this manual as required. Your personal safety and the proper operation of this machine depend upon the strict observance of these precautions.

The three types of advisories are defined as follows:

 WARNING	Indicates a potentially hazardous situation which, if not avoided, could result in death or serious injury.
 CAUTION	Indicates a potentially hazardous situation which, if not avoided, could result in minor or moderate injury. It could also be used to alert against unsafe practices.
NOTICE	Indicates a situation that could result in equipment or property-damage only accidents.

Important Environmental Concerns

Scientific research has shown that certain man-made chemicals can affect the earth's naturally occurring stratospheric ozone layer when released to the atmosphere. In particular, several of the identified chemicals that may affect the ozone layer are refrigerants that contain Chlorine, Fluorine and Carbon (CFCs) and those containing Hydrogen, Chlorine, Fluorine and Carbon (HCFCs). Not all refrigerants containing these compounds have the same potential impact to the environment. Trane advocates the responsible handling of all refrigerants-including industry replacements for CFCs such as HCFCs and HFCs.

Important Responsible Refrigerant Practices

Trane believes that responsible refrigerant practices are important to the environment, our customers, and the air conditioning industry. All technicians who handle refrigerants must be certified. The Federal Clean Air Act (Section 608) sets forth the requirements for handling, reclaiming, recovering and recycling of certain refrigerants and the equipment that is used in these service procedures. In addition, some states or municipalities may have additional requirements that must also be adhered to for responsible management of refrigerants. Know the applicable laws and follow them.

WARNING

Proper Field Wiring and Grounding Required!

Failure to follow code could result in death or serious injury. All field wiring MUST be performed by qualified personnel. Improperly installed and grounded field wiring poses FIRE and ELECTROCUTION hazards. To avoid these hazards, you MUST follow requirements for field wiring installation and grounding as described in NEC and your local/state electrical codes. Failure to follow code could result in death or serious injury.

⚠ WARNING

Personal Protective Equipment (PPE) Required!

Installing/servicing this unit could result in exposure to electrical, mechanical and chemical hazards.

- Before installing/servicing this unit, technicians **MUST** put on all PPE required for the work being undertaken (Examples; cut resistant gloves/sleeves, butyl gloves, safety glasses, hard hat/bump cap, fall protection, electrical PPE and arc flash clothing). **ALWAYS** refer to appropriate Material Safety Data Sheets (MSDS)/Safety Data Sheets (SDS) and OSHA guidelines for proper PPE.
- When working with or around hazardous chemicals, **ALWAYS** refer to the appropriate MSDS/SDS and OSHA/GHS (Global Harmonized System of Classification and Labelling of Chemicals) guidelines for information on allowable personal exposure levels, proper respiratory protection and handling instructions.
- If there is a risk of energized electrical contact, arc, or flash, technicians **MUST** put on all PPE in accordance with OSHA, NFPA 70E, or other country-specific requirements for arc flash protection, **PRIOR** to servicing the unit. **NEVER PERFORM ANY SWITCHING, DISCONNECTING, OR VOLTAGE TESTING WITHOUT PROPER ELECTRICAL PPE AND ARC FLASH CLOTHING. ENSURE ELECTRICAL METERS AND EQUIPMENT ARE PROPERLY RATED FOR INTENDED VOLTAGE.**

Failure to follow instructions could result in death or serious injury.

Copyright

This document and the information in it are the property of Trane, and may not be used or reproduced in whole or in part without written permission. Trane reserves the right to revise this publication at any time, and to make changes to its content without obligation to notify any person of such revision or change.

Trademarks

All trademarks referenced in this document are the trademarks of their respective owners.

Table of Contents

Controls	9
Types of Controllers	9
Wireless Remote Controller	9
Wired Controller	9
Wiring	9
Pushbutton Model	9
Simple Touchscreen Model	10
Power-up Sequence: Initial Power-up or Power Loss	10
Communication Loss Between the Wired Controller and the Indoor Unit ..	11
Scheduling	11
Zone Temperature Controls	11
Occupancy Modes	12
Operating and Status Modes	12
Heat Pump Mode Change With More than One Indoor Unit	12
Fan Operation and Status	13
Master/Slave Configuration	14
Programmable Touchscreen Controller	15
Wiring	15
Power-up Sequence	16
Zone Temperature Controls	16
Scheduling	17
Zone Management	17
Occupancy Modes	17
Morning Warm Up	17
Morning Cool Down	17
Operating and Status Modes	18
External Device Interlock	19
VRF System Controller	19
Manufacturers Proprietary Communications Protocol (NASA)	19
BACnet® Protocol	19
Wiring	20
Connecting to a VRF System Controller	22
Zone Temperature Controls	22
Scheduling	22
Occupancy Modes	22
User Interface	23
Peer-to-Peer Configuration	24
NASA Communications	25
BACnet Communications	25
Dedicated Control Logic	25
Custom Control Logic	26
Power Interface Module (PIM)	30
On/Off Controller	35

Indoor Units	36
Terms and Definitions	36
Electronic Expansion Valve (EEV)	36
EVA _{in} Temperature Sensor	36
EVA _{out} Temperature Sensor	36
Thermo On	36
Thermo Off	36
Air-Handling Unit (AHU) Kit	36
Return Air Temperature Sensor (RAT)	36
Discharge Air Temperature Sensor (DAT)	36
Indoor Unit Sequence of Operations	37
Electronic Expansion Valve (EEV)	37
Fan Speed Control	37
Operating Modes	39
Special Operations	41
Accessories	43
Louver Operation on Cassette Units	44
Motion Detector on Mini 4-Way Cassette Units	44
External Contact Control Board	45
Multi-Tenant Control Board	46
Mode Change Unit (MCU)	47
Component Identification	47
Modes of Operation	49
MCU Sequence of Operations	52
MCU EEV (equalizing EEV)	52
Heating Solenoid Valves	52
Cooling Solenoid Valves	52
Subcooling Loop	52
Subcooling EEV	52
Liquid Bypass Valve (LBV)	52
Subcooling Sensor	53
Low Ambient Cooling	53
Outdoor Unit	54
Definition of Terms	54
Heat Pump (HP)	54
Heat Recovery (HR)	54
Cooling	54
Mainly Cooling	54
Heating	54
Mainly Heating	54
High Pressure, High Temperature Gas	54
High Pressure, High Temperature Liquid	54
Low Pressure, Low Temperature Gas	54
Inverter Compressor	54

Vapor Injection	54
Outdoor Fan	54
Heat Exchanger (HX)	55
Cyclone Oil Separator	55
Accumulator	55
Accumulator Oil Return Valve (ARV)	55
Intercooler	55
Refrigerant Cooled Heat Sink (IPM)	55
Crankcase Heaters	55
High Pressure Sensor	55
Low Pressure Sensor	55
High Pressure Switch	56
Main EEV	56
Electronic Vapor Injection Electronic Expansion Valve (EVI EEV)	56
Electronic Vapor Injection (EVI) Bypass Valve	56
Electronic Vapor Injection (EVI) Solenoid Valve	56
Mainly Cooling Valve	57
Hot Gas Bypass Valve 1 (HGBP1)	57
Hot Gas Bypass Valve 2 (HGBP2)	57
4-Way Valve	57
Outdoor EEV Bypass Solenoid Valve	58
Outdoor EEV Bypass Check Valve	58
Discharge Check Valve	58
Heat Recovery (HR) Check Valve	58
Discharge Temperature Sensor (DTS)	58
Suction Temperature Sensor (STS)	58
Condenser (HX) Out Temperature Sensor	58
EVI _{in} and EVI _{out} Temperature Sensor	58
Liquid Tube Temperature Sensor (LTT)	58
Compressor Top Temperature (CTT)	58
Outdoor Temperature Sensor (ODT)	59
Service Valves	59
Discharge Superheat (DSH)	59
Subcooling Control (SC)	59
Superheat (SH)	59
Superheat Control	59
Safety Start	59
Normal Start	59
Cold Start	59
Normal Operation	59
Cold Operation	59
Quick Start	60
Oil Recovery Cycle	60
Pump Down	60
Pump Out	60
Component Locations and Descriptions: Air-Cooled Units	61

Component Locations and Descriptions: Water-Cooled Units	65
Flow Switch (Water-Cooled Unit)	68
Strainer (Water-Cooled Unit)	68
Flow Control Valve (Water-Cooled Unit)	69
Water Pump (Water-Cooled Unit)	70
Modes of Operation	71
Heat Pump	71
Heat Recovery	71
Water-Cooled Units: Heat Pump Installations	74
Outdoor Unit and Compressor Operating Priority	77
Compressor Starting and Rotation	77
Special Functions	78
Emergency Compressor Operation	78
Cooling Capacity Correction	78
Heating Capacity Correction	78
Current Restriction Rate	79
Outdoor Unit Fan Speed Correction	79
Nighttime Silent Mode	79
High Head Condition Setting	80
Long Piping Situation	80
Energy Saving Mode	80
Expanded Operation for Low Ambient Cooling	81
Snow Accumulation Prevention	81
VRF System	82
System Start Conditions	82
Air-Cooled Units	82
Water-Cooled Units	82
Cooling Mode	83
Compressor Starting Sequence	83
Normal Start	84
Indoor Unit Fan Operation in Cooling Mode	86
Heating Mode	86
Compressor Starting Sequence	86
Normal Start	87
Indoor Unit Fan Operation in Heating Mode	89
Mainly Cooling Mode (Heat Recovery Units Only)	90
Mainly Heating Mode (Heat Recovery Units Only)	90
Mode Change: Heat Pump System	90
Mode Change: Heat Recovery System	90
Special Operations	91
Oil Recovery Mode	91
Intelligent Defrost	92
Pump Down/Out	94

Freeze Protection	95
Safety Start	95
Mild Start	95
Cold Start	95
Cold Operation	96
Normal Start	97
Quick Start	97
Low Ambient Cooling	98
Discharge Air Control	98
Auto-Commissioning Mode	98

Controls

Types of Controllers

- Wireless remote controller
- Wired controller: pushbutton and touchscreen
- Programmable touchscreen controller
- VRF System Controller: BACnet and not
- Power interface module (PIM)
- On/Off controller

Wireless Remote Controller

When a button is pushed, the wireless remote controller emits a 180° infrared signal. This signal is received by any indoor unit receiver within range.

Note: Ducted units must have a duct signal receiver (purchased separately) installed to receive the wireless remote controller signal.

Wired Controller

Wiring

Wiring is accomplished for wired remote controllers on the dedicated layer, F3/F4.

Figure 1. Wired remote controllers communicating on F3/F4 layer

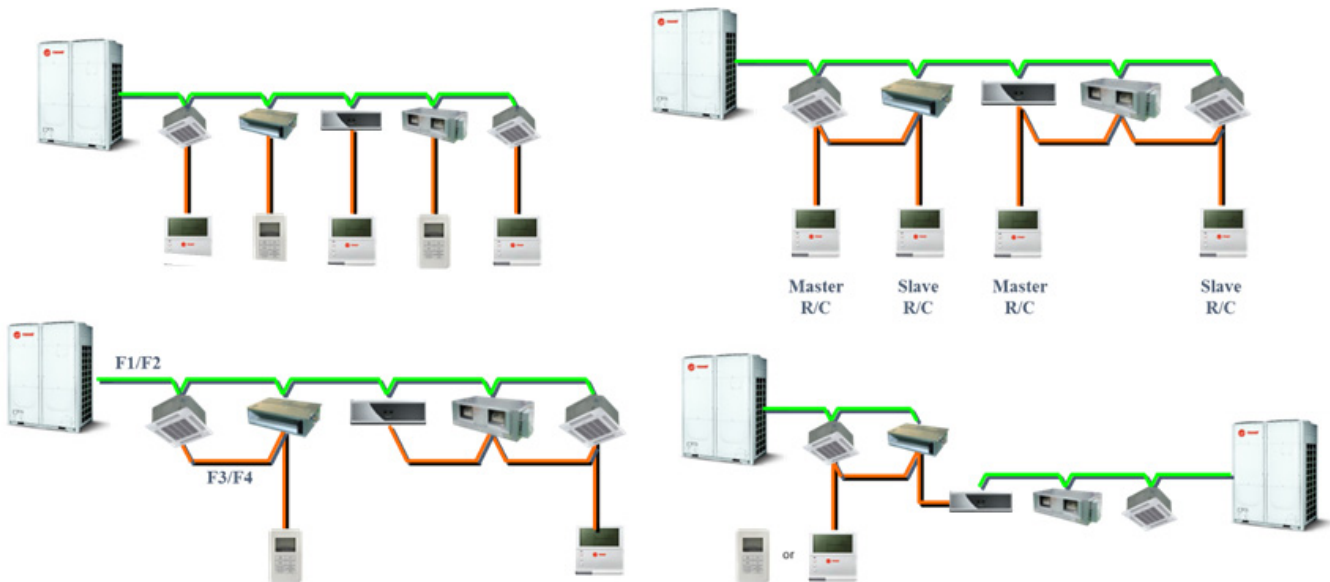

Pushbutton Model

The pushbutton model of the communicating, programmable wired controller can control up to 16 indoor units per controller.

Controls

- Default temperature range of 64°F–86°F
- Blade control from 32–65 degrees
- Weekly/daily operating schedule and daylight savings time adjustment
- On-board thermistor to sense space temperature (if configured to do so in wired controller; default is RAT sensor in indoor unit)
- Error display
- Filter reset timer
- Restricted operation can be enabled to restrict operation of:
 - Upper and lower temperature limits
 - Mode
 - Fan mode
 - On/off control

Simple Touchscreen Model

The simple touchscreen model of the communicating, non-programmable wired controller can perform basic operations on up to 16 indoor units per controller.

- Default temperature range of 64°F–86°F
- Blade control from 32–65 degrees
- Weekly, daily operating schedule and daylight savings time adjustment.
- On-board thermistor to sense space temp (if set in wired controller to do so, default is RAT sensor in indoor unit).
- Error display
- Filter reset timer
- Restricted operation can be enabled to restrict the operation of:
 - Upper and lower temperature limit
 - Mode
 - Fan mode
 - On/off control

Power-up Sequence: Initial Power-up or Power Loss



When power is applied, the wired controller will attempt to communicate with the indoor unit(s). If communications is lost for more than 3 minutes, E604 will display.

Wired controllers receive 12 Vdc power and communication from the indoor unit terminals F3/F4.

After communication is established, the wired controllers will remain off until they are commanded on by a VRF System Controller, a building automation system (BAS), or manually turned on by the occupant at the wired controller.

- If the wired controller is commanded on by a BAS using custom control logic, the setpoint and mode will be determined by that logic.
- If a BAS is not used, the wired controller will have to be commanded on by the occupant and manually changed to the desired setpoint (because the default is 76°F) and mode. Or if a schedule has been programmed, wait until the next scheduled interval.

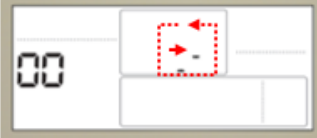
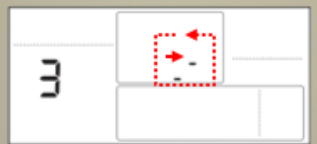
Figure 2. Power-up Sequence

Operation	Display
Power reset	 <p>All the LCD segments are ON for 1 second.</p>
Registration (Start)	 <p>Two segment on the temperature display rotates clockwise to search for indoor unit registration process</p>
Registration (Success)	 <p>Display all connected unit quantity.</p>
Normal operation	 <p>Display connected unit operation state.</p>

Communication Loss Between the Wired Controller and the Indoor Unit

If communications is lost for more than 3 minutes, E601 will display:

- If set by the wired controller installer set-up options, the indoor unit will ignore the built-in temperature sensor of the wired controller and will use the return air temperature sensor. It will heat and cool to the last setpoint that was given.
- Since the RAT sensor is the default sensor during a communication loss, the Heating mode temperature compensation setting will default to the value set by the product option code specific to the indoor unit type (3.6°F or 9°F).
- When communication is restored, the wired controller temperature sensor becomes the lead sensor again. The default temperature is 76°F. Heating mode temperature compensation is set back to 0°F.

Scheduling

The programmable wired controller can schedule up to 6 events per day.

Zone Temperature Controls

Return air temperature (RAT) sensor: The temperature is sensed by the RAT sensor by default.

Pushbutton wired controller (TVCTRLTWRWD01T): If set by the wired controller installation set up options, the zone temperature can be sensed by the thermistor in the pushbutton wired controller.

Wired external temperature sensor (TVCTRLTRWTA000): If set by the wired controller installation set up options, a remote temperature sensor can be used to sense zone temperature. It replaces the RAT sensor and is mounted within 33 feet of the unit.

Space temperature averaging can be accomplished in two ways:

- By using two pushbutton wired controllers and their temperature sensors in conjunction with the RAT sensor of each indoor unit.

- By using a single programmable wired controller and its temperature sensor as well as each RAT sensor in each of the indoor units that the wired controller is controlling.

Occupancy Modes

Occupied

Occupied mode is not available. The use of a setback period must be scheduled in the pushbutton wired controller (TVCTRLTWRWD01T). The scheduled setback period will dictate time, setpoint, and mode for the indoor unit(s) during this interval.

Morning Warm Up

Must be set up as a scheduled interval through VRF System Controller or other BAS if BACnet is utilized.

Morning Cool Down

Must be set up as a scheduled interval through VRF System Controller or other BAS if BACnet is utilized.

Unoccupied

There is not an unoccupied mode available. The use of a setback period must be set by schedule in the pushbutton wired controller (TVCTRLTWRWD01T). The scheduled setback period will dictate time, setpoint, and mode for the indoor unit(s) during this interval.

Operating and Status Modes

Indicates operation and status of indoor unit.

- Auto—Unit will run for comfort heating or cooling based on setpoint for a Heat Recovery system. Works for a Heat pump system only if set up as a 1-to-1 system.
- Cooling—Unit is set to Cooling mode and will satisfy comfort cooling setpoint. Will not change to Heating mode unless manually changed.
- Heating—Unit is set to Heating mode and will satisfy comfort heating setpoint. Will not change to Cooling mode unless manually changed.
- Dry—A manual dehumidification mode. Reduces fan speed while maintaining a comfort cooling setpoint.
- Fan—Unit will run fan only.

Heat Pump Mode Change With More than One Indoor Unit

At startup, in a mode of operation (Heating or Cooling), the wired controller will limit operation to that specific mode (Heating only or Cooling only) and will not allow the selection of the opposite mode.

Removal of the heat pump limit is accomplished in one of three ways:

Manual

1. Turn off all indoor units.
2. Turn one indoor unit on.
3. Change mode of operation to that unit. This will change the mode of operation of a heat pump system.
4. Turn remaining indoor units on to the same mode.

Time and manual

1. All indoor units have transitioned to thermal off (satisfied).
2. A 30-minute timer expires with no new call.

3. Manually change to the opposite mode at the wired controller.

Mode Master

Mode master is a designation of one indoor unit to control or manipulate the mode of a heat pump system.

Mode Master Auto Mode:

1. The unit that has been identified as mode master must be connected to one wired controller.
2. Push the mode button on the wired controller for 5 seconds. To release mode master, press the fan button for 5 seconds.
3. On all indoor units in the system, increase digit 5 of the product option code by 2 increments.
4. The unit will change mode based on the setpoint of mode master.

Mode Master Manual Mode:

1. The unit that has been identified as mode master must be connected to one wired controller.
2. Push the mode button on the wired controller for 5 seconds. To release mode master, press the fan button for 5 seconds.
3. Manually change the mode of the mode master at the wired controller.

Figure 3. Mode master

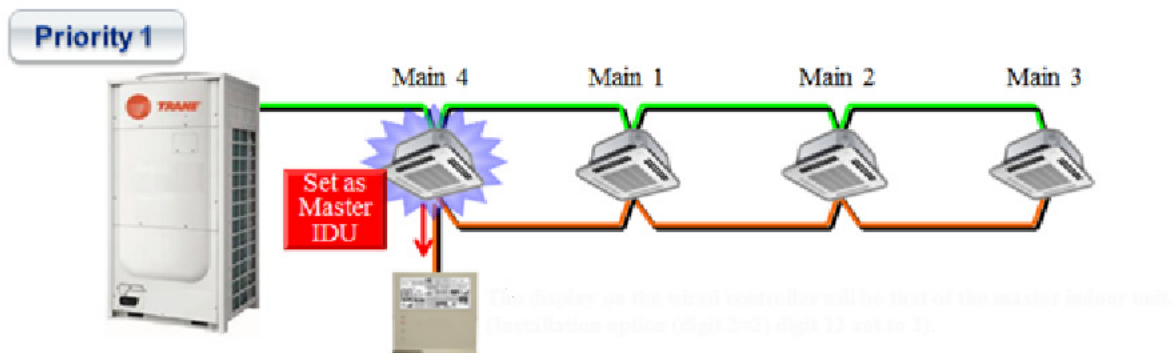

Fan Operation and Status

Indicates status of fan operation and speed. Can be set to auto or manual.

Table 1, p. 14 shows the relationship of fan operation to operating mode.

Auto

When set to Auto, the fan profile will follow a predetermined control logic based on the difference between space temperature and setpoint. It cannot be manipulated or changed while in this mode.

If an indoor unit is set to Auto mode, the fan will be automatically set to Auto mode and cannot be changed.

Manual

When fan mode is set to Manual, the fan will run at High/Mid/Low setting.

Controls

Table 1. Fan operation in relation to unit operating mode

Operating mode	Fan speed	EEV	Temperature range	Remark
Auto	Fixed logic, Auto ($\Delta T = \text{Setpoint} - \text{space temperature}$) Low: $1.8^{\circ}\text{F} < \text{Mid} \leq 5.4^{\circ}\text{F}$: High	Logic control	65–86°F	User selection
Cooling	Manual user input (Low, Mid, High, Auto)	Logic control	65–86°F	User selection Minimum 61°F for high-wall
Dry	Fixed logic, Auto (Low, Low Low ^(a) or Ultra Low ^(b))	Logic control	65–86°F	User selection Minimum 61°F for high-wall
Heating	Manual user input (Low, Mid, High, Auto)	Logic control	65–86°F	User selection
Turbo (while Cooling/ Heating)	Fixed logic, High, or Turbo	Logic control	Current setting	High-wall units only with wireless remote. Operates for 30 minutes, then returns to previous setting.
Fan	User input (Low, Mid, High)	Fixed (closed)	—	User selection
Defrost	Stopped	Fixed (open)	—	System
Oil recovery	If fan is on, fan will stay on. If fan is off, fan will stay off.	Logic control	—	System
Quiet	1) Fan feedback indoor unit (ex., high-wall, 1-way, 4-way): current fan speed -1 step 2) Fan non-feedback indoor unit (ex., duct): H → M, M → L, L → L	Logic control Fixed	Current setting	Minimize fan noise during Cooling or Heating mode.

Note: 1 step is equal to approximately 20 rpm

(a) Low Low: Low-1 step (feedback-type fan only [cassette, high-wall, convertible])

(b) Ultra Low: minimum step (non-feedback type fan only [ducted indoor unit]: 5 step + Low step x 0.25)

Master/Slave Configuration

Master/slave configuration dictates what is displayed on the slave wired controller. Configuration must take place at the wired controller.

Master/slave configuration is used when a system has multiple wired controllers or for averaging space temperatures across one or more indoor units/controllers.

Figure 4. Master/slave configuration for wired controller

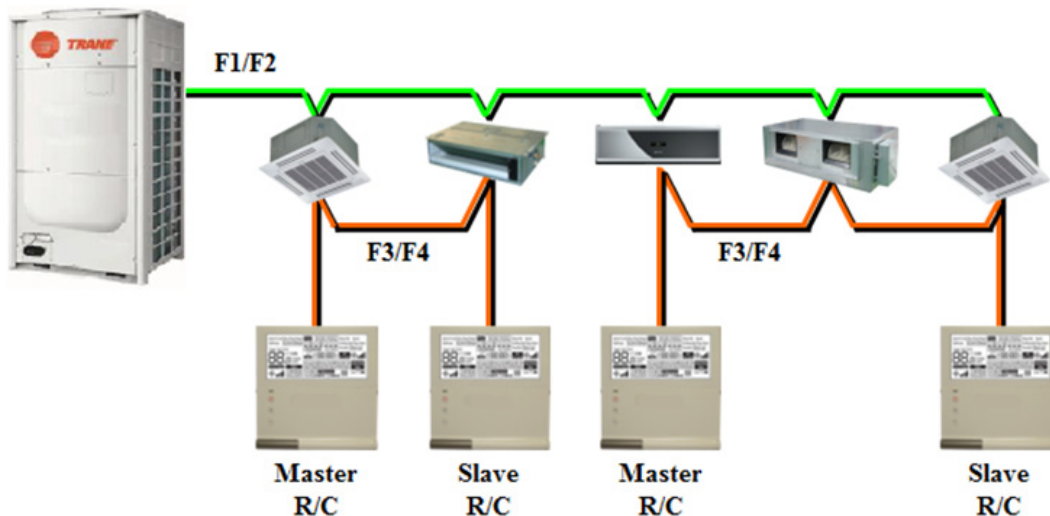

Programmable Touchscreen Controller

The programmable, communicating touchscreen has the following layers of communication:

Wiring

R1/R2

If wired to the R1/R2 layer of communication, you can see all systems tied to the R1/R2 layer using up to 16 touchscreen controllers.

Maximums on the R1/R2 layer:

- 16 outdoor unit system or 128 indoor units
- 1 VRF System Controller

Figure 5. R1/R2 layer

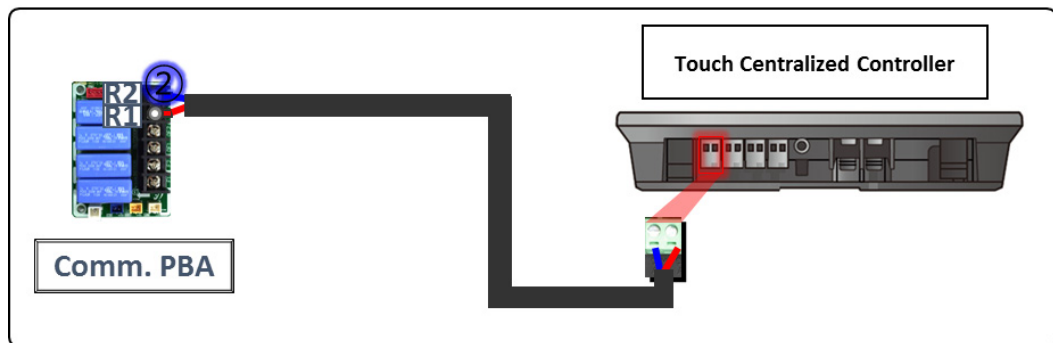
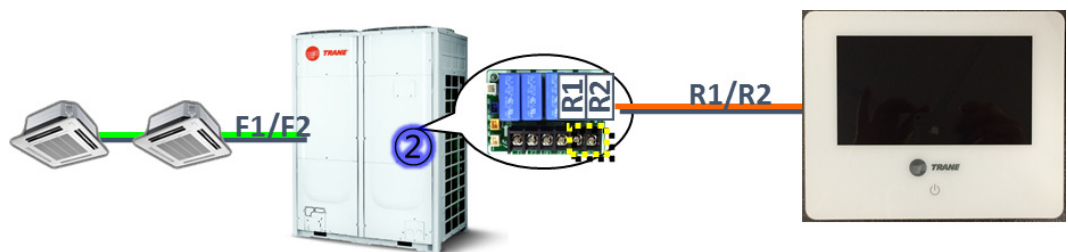

F1/F2

If wired to the F1/F2 layer of communication, you can see only the system that is wired to the same F1/F2 layer. See [Figure 6, p. 16](#).

Maximums on the same F1/F2 layer:

- 16 touchscreen controllers
- 1 outdoor unit and up to 64 indoor units

Figure 6. F1/F2 layer

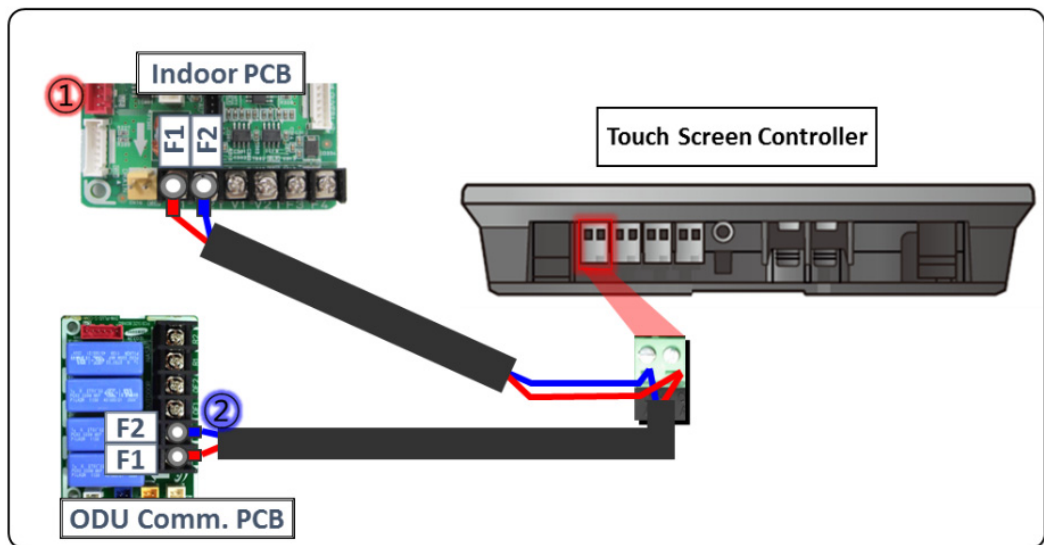

Power-up Sequence

- Power (115 Vac) applied after power loss and initial power up.
- Tracking is completed within 3 minutes of power up.
 - Check for communications status between devices and systems during tracking.
 - Check for quantity of devices.
 - Check for duplicated manual address of devices.
- Once complete, the touchscreen controller is operational and ready for use. If scheduling is not set up, system operation will have to be manually implemented.

Zone Temperature Controls

- Default temperature range of the touchscreen controller is 64°F–86°F.
- Can utilize the RAT sensor in the indoor unit(s) to maintain setpoint.
- Can utilize temperature sensor in wired controller to maintain setpoint (if configured in wired controller).
- Can use the external wired temperature sensor connected to an indoor unit to maintain setpoint.
- Zone temperature limits: Temperature limits can be set by the touchscreen controller while still maintaining local control within those limits. Zone temperature limits are set to limit the upper and lower setpoint at the local controller. See [Figure 7, p. 17](#).

Figure 7. Touchscreen upper and lower limit control

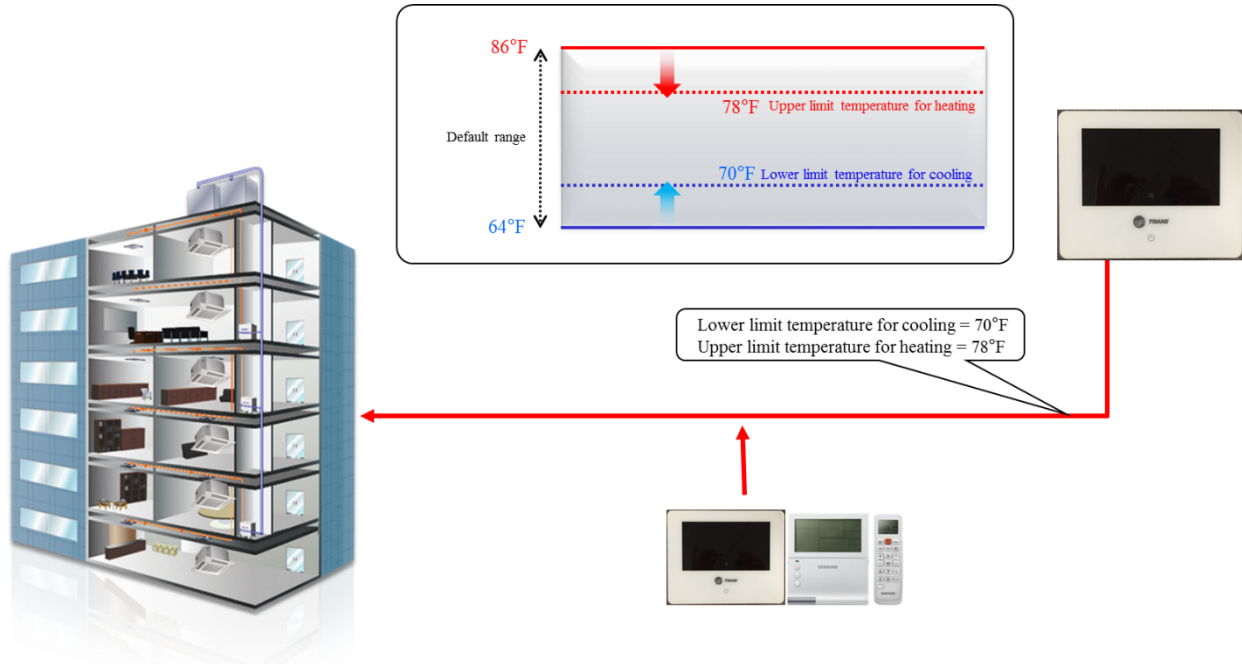

Scheduling

- Up to 10 events per day can be scheduled.
- Daily, weekly, and exception day schedules can be created.

Zone Management

- Maximum of 12 zones per controller
- Individual description and icon for each zone.

Occupancy Modes

- Occupied: There is no occupied mode available. A setback period must be set by use of the schedule in the touchscreen controller. The scheduled setback period dictates time, setpoint, and mode for the indoor unit(s) during this interval.
- Unoccupied: There is no unoccupied mode available. A setback period must be set by use of the schedule in the touchscreen controller. The scheduled setback period dictates time, setpoint, and mode for the indoor unit(s) during this interval.

Morning Warm Up

This mode must be set up as a scheduled interval through the VRF System Controller or other BAS if BACnet® is utilized.

Morning Cool Down

This mode must be set up as a scheduled interval through the VRF System Controller or other BAS if BACnet is utilized.

Operating and Status Modes

Auto

Unit will run to satisfy comfort heating or cooling based on setpoint for a Heat Recovery system. Does not work for Heat Pump system unless it is set up as a 1-to-1 system.

Cooling

Unit is set to Cooling mode and will satisfy comfort cooling setpoint. Will not change to Heating mode unless manually changed.

Heating

Unit is set to Heating mode and will satisfy comfort heating setpoint. Will not change to Cooling mode unless manually changed.

Fan

Unit will run fan only.

Restriction Mode

The touchscreen controller can limit lower level controllers and system mode of operation. The following restrictions are possible (see "Remote Control" in the Touchscreen Control IOM (VRF-SVX37*) for details):

- Cooling only
- Heating only
- Schedule
- Enable remote control
- Disable remote control
- Conditional remote control
- Heat pump mode change: Used to prevent mixed-mode operation of a heat pump. At start up, in a mode of operation (heating or cooling), the touchscreen controller will restrict operation to that specific mode (heating only or cooling only) until the restriction is removed. Removal of the restriction is accomplished in one of two ways:

Manual	
	1. Turn off all indoor units.
	2. Remove the restriction in the touchscreen.
	3. Turn on indoor units.
	4. Change mode of operation; minimum 1 indoor unit.
Manual over time	
	1. All indoor units have transitioned to thermal off (satisfied).
	2. A 30-minute timer expires with no new call.
	3. The opposite mode is called for by an indoor unit or manually shifted to the opposite mode.

External Device Interlock

The ability to interlock external devices to the touchscreen controller.

External device interlock is controlled by using 2 digital inputs. Three possible interlock patterns are available, which are selectable in the touchscreen controller under system settings “DI Patterns” (refer to [Figure 8](#), [Figure 9](#), and the Touchscreen Control IOM (VRF-SVX37*) for more details).

Figure 8. External device interlock patterns: functions

Pattern	Control	Contact Input
1	No function (default setting)	Not applied
2	DI 1. Emergency stop operation. (Closed = Stop, Open = Standby) All indoor units stop operating and any command is ignored	closed/open contact
	DI 2. No function	
3	DI 1. All indoor unit ON/OFF control (Short: ON / Open: OFF)	Short / open contact
	DI 2. Permitted/Prohibited remote controller use (Short: Permitted / Open: Prohibited)	
4	DI 1. All indoor unit ON control	Short Pulse
	DI 2. All indoor unit OFF control	

Figure 9. External device Interlock patterns: external contacts

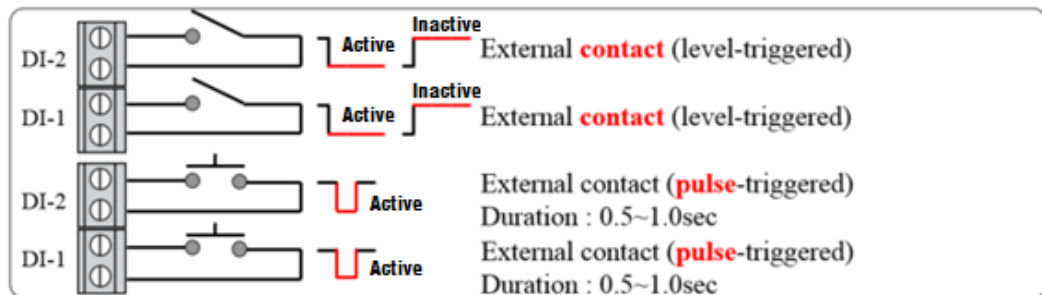

Monitor indoor unit operation on/off and error status through 2 digital outputs.

- If one or more indoor unit(s) are turned on, DO1 will close.
- Maximum rating is 12 Vdc @10 mA.

VRF System Controller

The VRF System Controller is available in two versions, each uses a different communication protocol. Both are user name and password protected, and accessible over public and private IP. They provide scheduling, control, and logic-based operation.

Manufacturers Proprietary Communications Protocol (NASA)

Provides system communication for a stand-alone upper-level building automation system (BAS). Allows remote access through a public IP.

BACnet® Protocol

Used as a gateway to interface with an upper-level BAS through the BACnet protocol.

Wiring

Communications wiring for the VRF System Controller is tied into the R1/R2 layer of communications. Two wiring scenarios are possible:

- Home run from main outdoor unit of each system
- Daisy chain of main outdoor unit from each system.

Figure 10. VRF System Controller communication wiring on R1/R2 layer; maximum number of connected devices

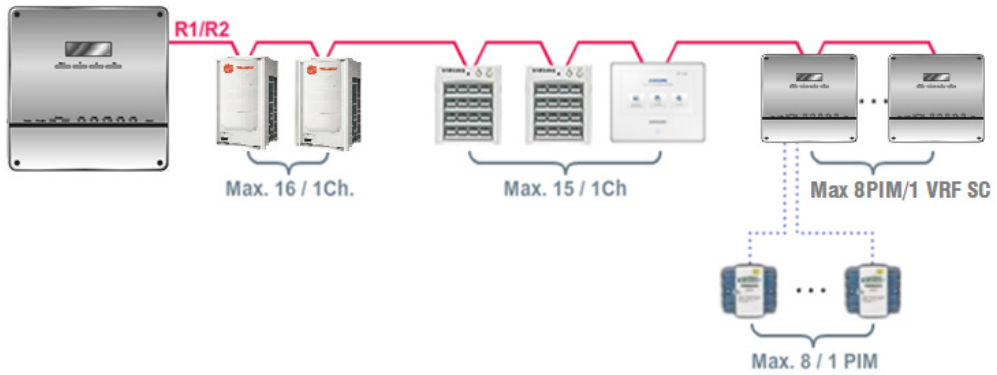
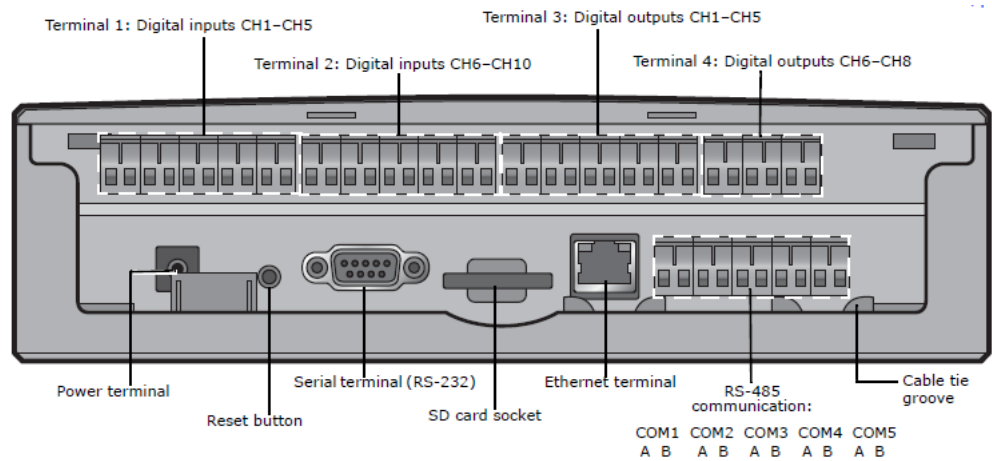

Figure 11. Bottom of VRF System Controller showing wiring terminals



Maximum Number of Connected Devices

- Outdoor unit maximum: 80 (must not exceed 16 units per each RS-485 communication terminal x 5 channels)
- Indoor unit and MCU maximum: 256 (must not exceed 128 per each RS-485 communication terminal).
- Controller maximum: 75 (15 per channel)
- Power meter interface module (PIM) maximum: 8
- Watt-hour meter: 64 (maximum of 8 meters can be connected to a PIM)

Addressing Requirements

- If multiple VRF systems are monitored by a VRF System Controller, each system must have a unique address. The address is set at the main outdoor unit of each system.
- If multiple PIMs are monitored by a VRF System Controller, each PIM must have a unique address. This is set at the rotary switches inside the PIM.

Power-up Sequence

- Power initialized (115 Vac) to VRF System Controller for initial addressing.
- Check for communications status between devices and systems during tracking.

Figure 12. Power-up sequence

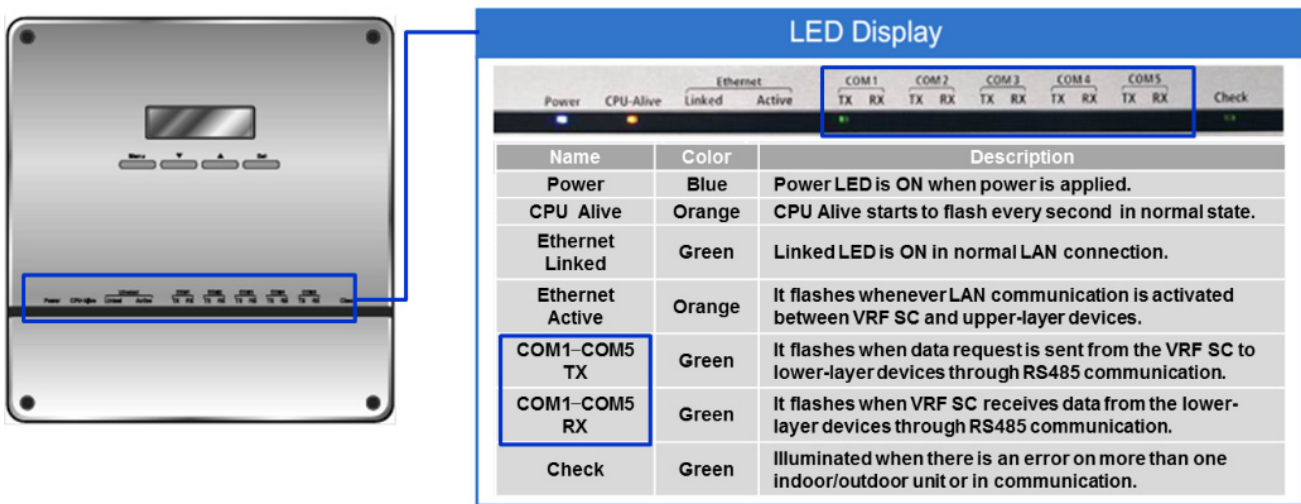

- Check the communication by channel.



- Perform the tracking operation to check for quantity of devices.
- Check for duplicated manual address of devices.
- Verify communication.
- If start up is unsuccessful for 3 minutes, an error code will display (may take longer for larger systems).

Note: If tracking fails, correct error(s) and reboot using the reset button on the VRF System Controller. (See circled button in Figure 13.

Figure 13. Reboot button



- After the power-up sequence is complete, the IP address and time are displayed. The VRF System Controller is now operational and ready for use.

Connecting to a VRF System Controller

Direct connection through a LAN cable (must be done initially at start up)

Connect the Ethernet cable to the Ethernet terminal (shown in [Figure 11, p. 20](#)).

Connect the Ethernet cable to the VRF System Controller in one of the following ways:

- Directly to a BACnet/IP system controller such as the Trane® Tracer System Controller.
- Directly to a PC for access to the VRF System Controller+BACnet Web user interface
- To both a BACnet/IP system controller and a PC through the use of a router.

Linked LED is ON when LAN connection is made between VRFSC and the PC

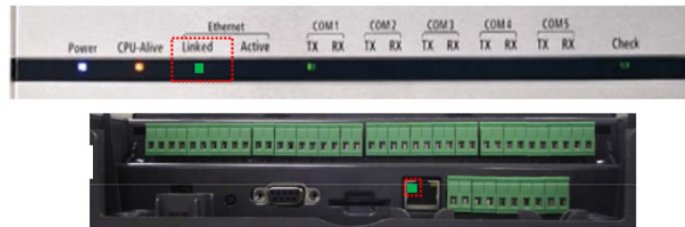

Zone Temperature Controls

- Can utilize the RAT sensor in the indoor unit(s) to maintain setpoint.
- Can utilize temperature sensor in wired controller to maintain setpoint.
- Can use the external wired temperature sensor to maintain setpoint.

Scheduling

- Maximum of 70 events per week
- Maximum of 10 events per day
- Maximum of 256 schedules

Occupancy Modes

- Occupied—No occupied mode is available. Must be set up as a scheduled setback period in the VRF System Controller. The scheduled setback period will dictate time, setpoint, and mode for the indoor unit(s) during this interval.
- Unoccupied—No unoccupied mode is available. Must be set up as a scheduled setback period in the VRF System Controller. The scheduled setback period will dictate time, setpoint, and mode for the indoor unit(s) during this interval.
- Morning warm up—Must be set up as a scheduled interval.
- Morning cool down—Must be set up as a scheduled interval.

User Interface



- Powering on and off indoor unit(s)
- Enable or disable wired controller—User limitations
- Space temperature—actual space temperature where sensed.
- Set temperature—Heating or cooling setpoint
- Discharge air setpoint (ducted units and AHU only). The indoor unit will control to the comfort heating or cooling setpoint using the discharge air temperature setpoint. When discharge air control is enabled the temperature limitations are 46–64°F degrees in cooling. For heating, it is 86–109°F degrees. The system will control to the comfort heating or cooling setpoint first and the discharge air temperature second.

Mode of Operation

- Auto—Unit will run for comfort heating or cooling based on setpoint for a Heat Recovery system. Does not work for Heat Pump system unless it is set up as a 1 to 1 system.
- Cooling—Unit is set to cooling mode and will satisfy comfort cooling setpoint. Will not change to heating unless manually changed.
- Heating—Unit is set to heating mode and will satisfy comfort heating setpoint. Will not change to cooling unless manually changed.
- Dry—A manual dehumidification mode. Reduces fan speed while maintaining a comfort cooling setpoint.

Fan Mode of Operation

- Auto will allow the fan to follow Auto Heat or Cool fan profiles
- High runs the fan in high speed only
- Medium runs the fan in medium speed only

Controls

- Low runs the fan in low speed only

Louver Operation

Controls louver operation of cassette, highwall, and convertible units.

Enable Discharge Air Control

Must be set to activate discharge air setpoint.

Mode Restriction

Restricts the mode of operation of the system.

Upper and Lower Temperature limits

Figure 14. Indoor unit usage restriction

Control and Monitoring

- Cycle monitoring
- **Indoor unit usage restriction**
- Trouble history
- Outdoor unit control
- Control for unoccupied room
- Checking operation status

Indoor unit usage restriction					
Address	Name	Limit mode	Control mode	Lower temperature limit in Cool mode	Upper temperature limit in Heat mode
11.01.00(00)	Highwall	Cool Only	Cool	<input type="radio"/> Disable <input checked="" type="radio"/> Enable <input type="text" value="64.0"/> °F	<input type="radio"/> Disable <input checked="" type="radio"/> Enable <input type="text" value="86.0"/> °F
11.01.01(00)	Ceiling	None	None	<input type="radio"/> Disable <input checked="" type="radio"/> Enable <input type="text" value="64.0"/> °F	<input type="radio"/> Disable <input checked="" type="radio"/> Enable <input type="text" value="86.0"/> °F
11.01.02(00)	HSP	Heat Only	Heat	<input type="radio"/> Disable <input checked="" type="radio"/> Enable <input type="text" value="64.0"/> °F	<input type="radio"/> Disable <input checked="" type="radio"/> Enable <input type="text" value="86.0"/> °F
11.01.03(00)	MSP	None	None	<input type="radio"/> Disable <input checked="" type="radio"/> Enable <input type="text" value="64.0"/> °F	<input type="radio"/> Disable <input checked="" type="radio"/> Enable <input type="text" value="86.0"/> °F
11.01.04(00)	1 - way	None	None	<input type="radio"/> Disable <input checked="" type="radio"/> Enable <input type="text" value="64.0"/> °F	<input type="radio"/> Disable <input checked="" type="radio"/> Enable <input type="text" value="86.0"/> °F
11.01.06(00)	4-way	None	None	<input type="radio"/> Disable <input checked="" type="radio"/> Enable <input type="text" value="64.0"/> °F	<input type="radio"/> Disable <input checked="" type="radio"/> Enable <input type="text" value="86.0"/> °F
11.01.07(00)	4	Used to Restrict Mode		<input type="radio"/> Disable <input checked="" type="radio"/> Enable <input type="text" value="64.0"/> °F	<input type="radio"/> Disable <input checked="" type="radio"/> Enable <input type="text" value="86.0"/> °F

Peer-to-Peer Configuration

Multiple VRF System Controllers can be tied together using a CAT5 cable. Refer to Figure 15. Each VRF System Controller must be identified by a unique BACnet network number. The default BACnet number is "9". Additional VRF System Controllers must have a unique BACnet network number from "1" through "40" with the exception of the number "9".

Figure 15. Multiple VRF System Controllers using multiple CAT5 cables will operate independently of each other if tied together on a large project

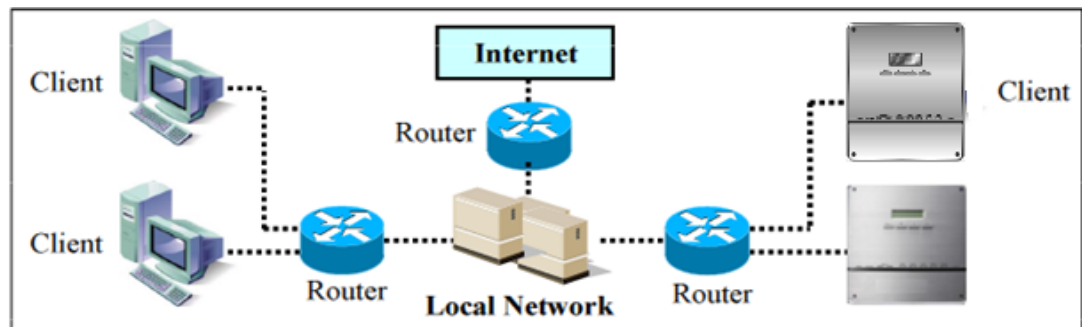

NASA Communications

Manufacturer’s proprietary communication. Third party integration is not possible.

BACnet Communications

VRF System Controller with BACnet protocol to allow third party integration for BAS. VRF System Controller becomes a gateway when integrated with third party BACnet controls.

- There are twenty-two available points: 9 readable points for monitoring; 13 writable points for control.
- Can utilize change of value (COV) or polling to update information (recommend polling to reduce the amount of network traffic).

Dedicated Control Logic

- Can be used to interlock system to pre-set shutdown or start up routines
- Four selectable preset patterns



- **Pattern 1:** (factory default) No external input
- **Pattern 2:** Emergency stop

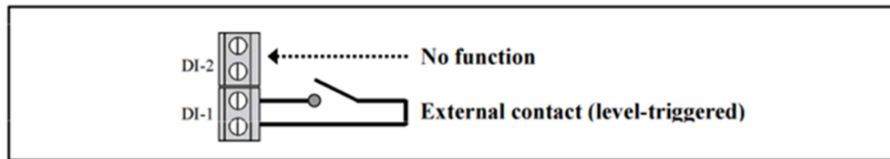

▪ **Short external contact : Emergency stop**

- Turns off all the indoor units when there is an ON signal input
- All the remote controllers are disabled
- VRFSC will ignore any request from the upper-level controller
- Schedule control is disabled temporarily

▪ **Open external contact : Resume operation**

- After Emergency stop, the indoor units stay in the current OFF state
- All the remote controller use is restored to the previous state
- Schedule control is enabled again

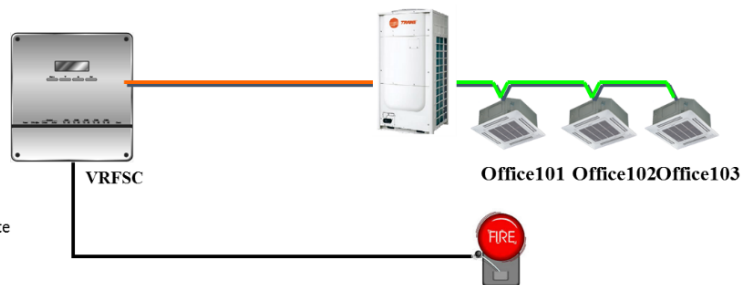

- **Pattern 3:** Operation/stop and remote control enable/disable

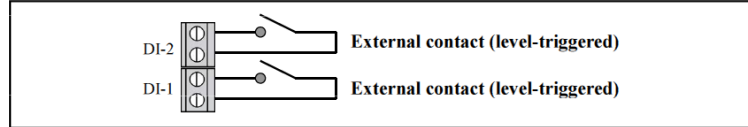

- **External contact input to DI-1**

- Short contact : Starts all indoor unit operation.
- Open contact : Stops all indoor unit operation.

- **External contact input to DI-2**

- Short contact : Disables the use of all wired/wireless remote controllers.
- Open contact : Enables the use of all wired/wireless remote controllers.

Schedule control is not interrupted in Pattern 3.

- **Pattern 4:** Pulse input (operation/stop)

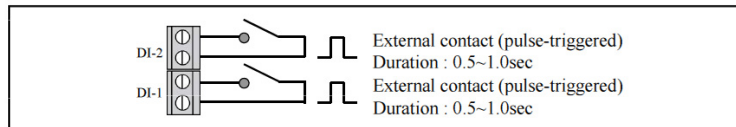

- **External contact pulse input to DI-1**

- Short pulse-triggered : Starts all indoor unit operation.

- **External contact pulse input to DI-2**

- Short pulse-triggered : Stops all indoor unit operation.

Schedule control is not interrupted in Pattern 4.

Custom Control Logic

- More than 75 custom control logic routines per VRF System Controller.
- Custom control logic that is based on specific inputs and written in the form of a custom routine can be used to control the system output (see example: [Figure 17–Figure 22](#)).
- 10 dedicated voltage-free inputs:
 - 2 are dedicated voltage-free inputs (follows selected pattern [refer to the four patterns shown in “Dedicated Control Logic” section])
 - 8 are voltage-free contact inputs (open/short contact input)
- 2 dedicated voltage-free outputs (operation/error)
- 6 outputs for interlocking with external systems (12 Vdc)
- 2 reserved outputs for future use
- Inputs and outputs each have a fixed address ([Figure 16](#))
 - Digital input address: 56.00.03–56.00.1
 - Digital output address: 56.01.03–56.01.08

Figure 16. VRF System Controller: inputs and outputs

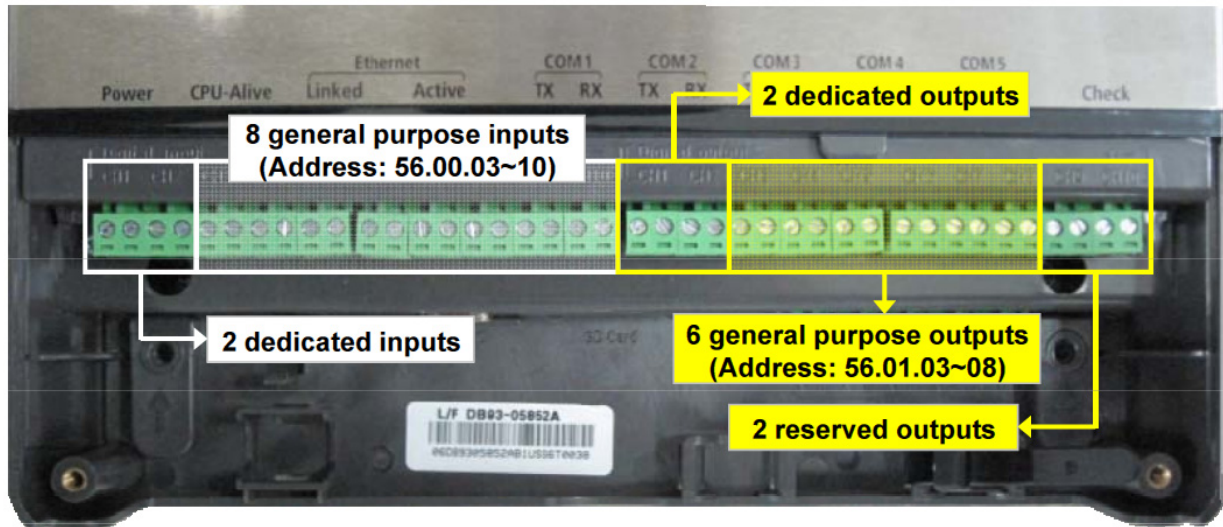

Figure 17. Custom control logic set up: Step 1

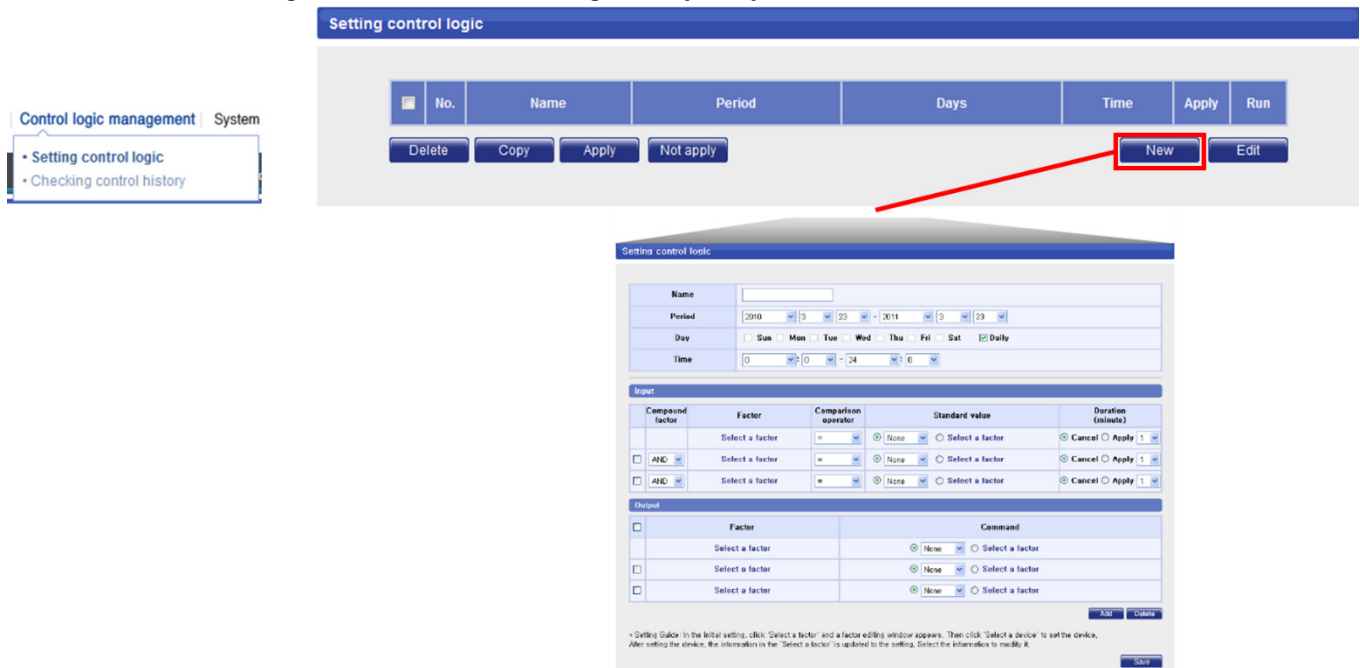

Figure 18. Custom control logic set up: Step 2

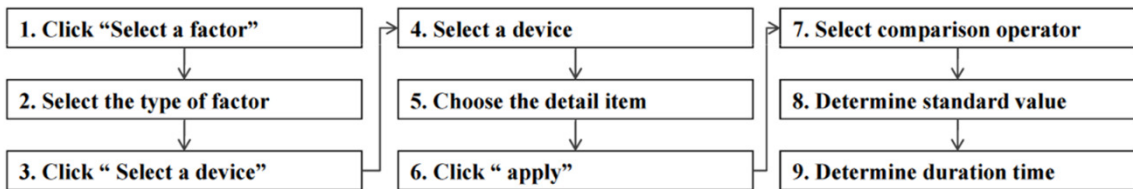

Figure 19. Custom control logic set up: Step 3

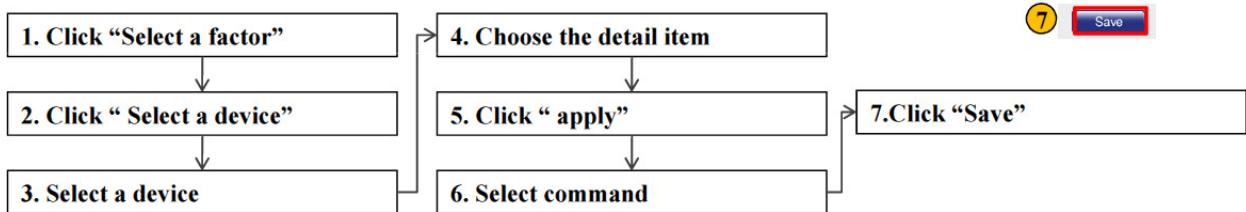
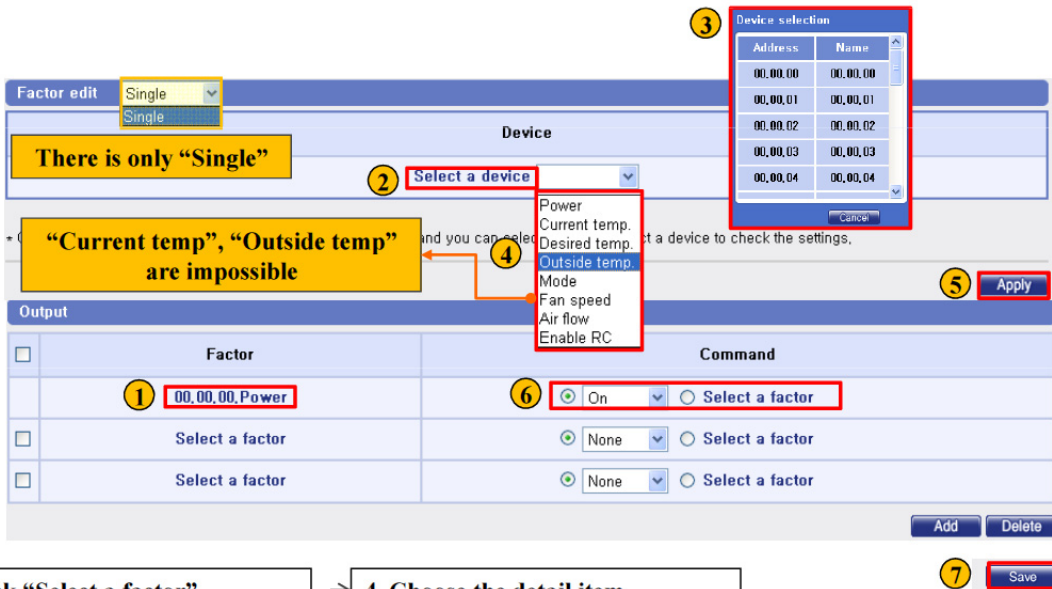

Figure 20. Applying custom control logic to indoor units: If (1) the outdoor air temperature is equal to or greater than 86°F, (2) for more than 5 minutes, then (3) power on all units.

1st Control logic

Name	PowerOn_Temp30			
Period	2010	3	23	- 2011
Day	<input type="checkbox"/> Sun <input checked="" type="checkbox"/> Mon <input checked="" type="checkbox"/> Tue <input checked="" type="checkbox"/> Wed <input checked="" type="checkbox"/> Thu <input checked="" type="checkbox"/> Fri <input type="checkbox"/> Sat <input type="checkbox"/> Daily			
Time	8	:	0	- 18

Input				
Compound factor	Factor	Comparison operator	Standard value	Duration (minute)
1	00,00,00,Outdoor temp.	=>	86°F	2 <input checked="" type="radio"/> Apply 5
<input type="checkbox"/>	AND Select a factor	=	None	<input checked="" type="radio"/> Cancel <input type="radio"/> Apply 1
<input type="checkbox"/>	AND Select a factor	=	None	<input checked="" type="radio"/> Cancel <input type="radio"/> Apply 1

Output	
Factor	Command
3 <input checked="" type="checkbox"/> 00,00,00,Power	<input checked="" type="radio"/> On <input type="radio"/> Select a factor
<input checked="" type="checkbox"/> 00,00,01,Power	<input type="radio"/> On <input type="radio"/> Select a factor
<input checked="" type="checkbox"/> 00,00,02,Power	<input type="radio"/> On <input type="radio"/> Select a factor
<input checked="" type="checkbox"/> 00,00,03,Power	<input type="radio"/> On <input type="radio"/> Select a factor

Figure 21. Applying custom control logic to indoor units: If (1) the outdoor air temperature is equal to or less than 78°F, then (2) power off all units.

2nd Control logic

Name	PowerOff_Temp25			
Period	2010	3	23	- 2011
Day	<input type="checkbox"/> Sun <input checked="" type="checkbox"/> Mon <input checked="" type="checkbox"/> Tue <input checked="" type="checkbox"/> Wed <input checked="" type="checkbox"/> Thu <input checked="" type="checkbox"/> Fri <input type="checkbox"/> Sat <input type="checkbox"/> Daily			
Time	8	:	0	- 18

Input				
Compound factor	Factor	Comparison operator	Standard value	Duration (minute)
1	00,00,00,Outdoor temp.	=<	78°F	<input checked="" type="radio"/> Cancel <input type="radio"/> Apply 1
<input type="checkbox"/>	AND Select a factor	=	None	<input checked="" type="radio"/> Cancel <input type="radio"/> Apply 1
<input type="checkbox"/>	AND Select a factor	=	None	<input checked="" type="radio"/> Cancel <input type="radio"/> Apply 1

Output	
Factor	Command
2 <input checked="" type="checkbox"/> 00,00,00,Power	<input checked="" type="radio"/> Off <input type="radio"/> Select a factor
<input checked="" type="checkbox"/> 00,00,01,Power	<input type="radio"/> Off <input type="radio"/> Select a factor
<input checked="" type="checkbox"/> 00,00,02,Power	<input type="radio"/> Off <input type="radio"/> Select a factor
<input checked="" type="checkbox"/> 00,00,03,Power	<input type="radio"/> Off <input type="radio"/> Select a factor

Note: Custom control logic must be applied to indoor units to take effect.

Figure 22. Custom control logic applied to indoor units



Power Interface Module (PIM)

Used for tenant billing applications.

- System requirements
- Current source is VRF System Controller
- Field-supplied watt-hour meter
 - Watt-hour meter shall be dry contacts
 - Pulse rate: 1–10,000 Wh/pulse rate (no decimal pulse rate allowed)
 - Pulse width: 20–400 ms (in 1 ms units) with $\pm 5\%$ tolerance
 - Time interval between pulses: 3 ms minimum
 - Must be able to handle: 15 mA minimum
 - Withstanding voltage: 15 Vdc minimum
- Field-supplied current transformer
 - Must be sized to system amperage
 - Trane® has partnered with Continental Control Systems LLC to provide kits for our systems. Please contact Continental Control Systems for pricing and availability at 888-928-8663.
- Terms and definitions
 - Main capacity is the total capacity requested by the indoor units that are operating.
 - Fan capacity is the fan speed and power consumed depending on motor type (feedback vs. non-feedback motor, depends on the indoor unit type)
 - Standby capacity is the capacity of the indoor units that are powered on but not operating.
 - System power consumption includes:
 - Main power

- Fan power
- Stand-by power
- Compressor operation
- Indoor/outdoor unit fan operation
- Indoor/outdoor main control board

Figure 23. Power-consuming devices

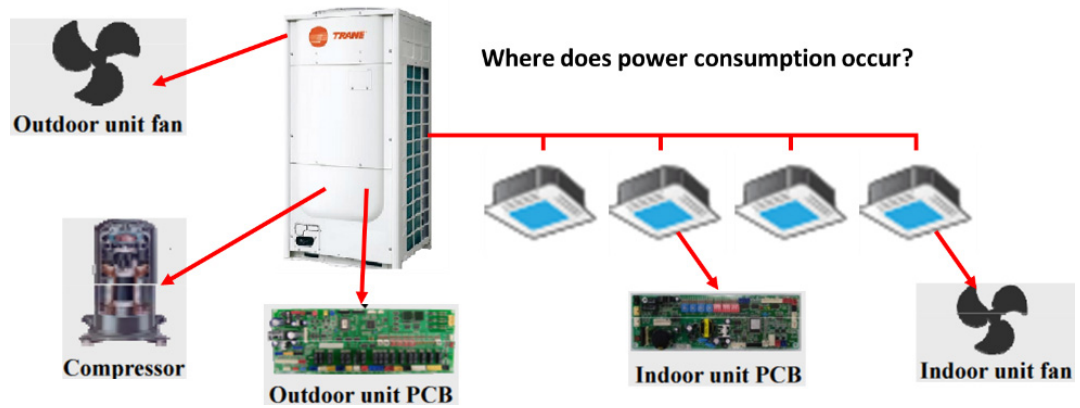
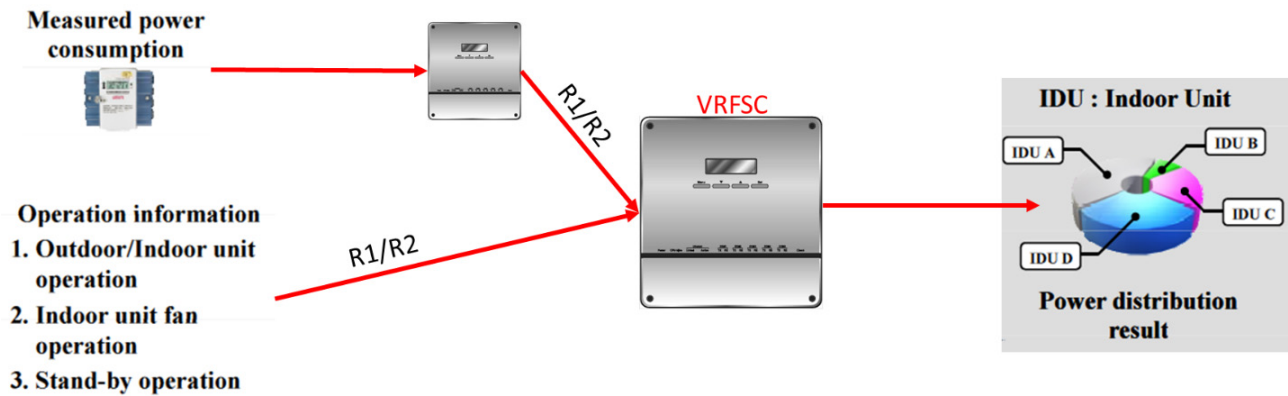

Figure 24. Calculation of power consumption



$$\text{IDU A's electric power consumption} = \text{Total power consumption} \times \frac{\text{Demand capacity of IDU A}}{\text{Total demand capacity of all IDUs}}$$

Here, Demand capacity = Main capacity + Fan capacity + Stand-by capacity

Figure 25. How power consumption is measured

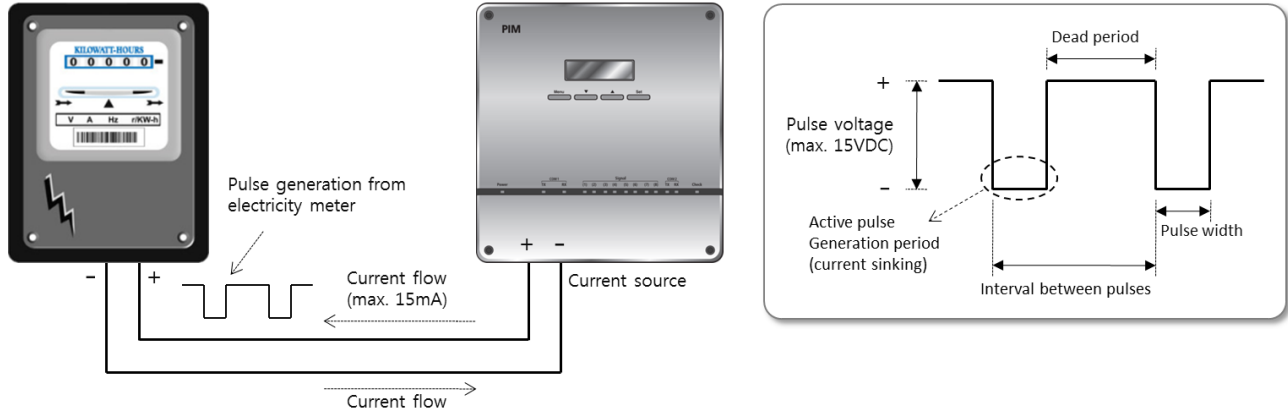

Figure 26. Power usage data storage

VRFC gathers power consumption and capacity values every minute through the centralized controllers and watt-hour meter interface modules. At midnight, 1-day power consumption is distributed with the gathered information to the indoor units.

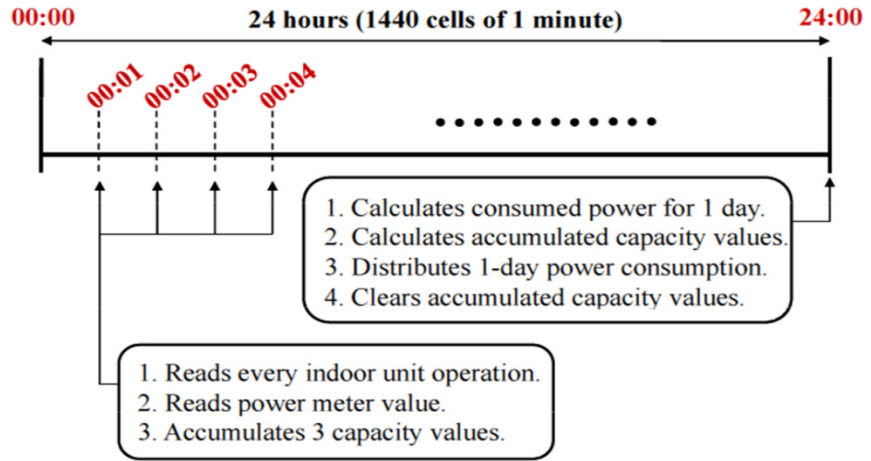
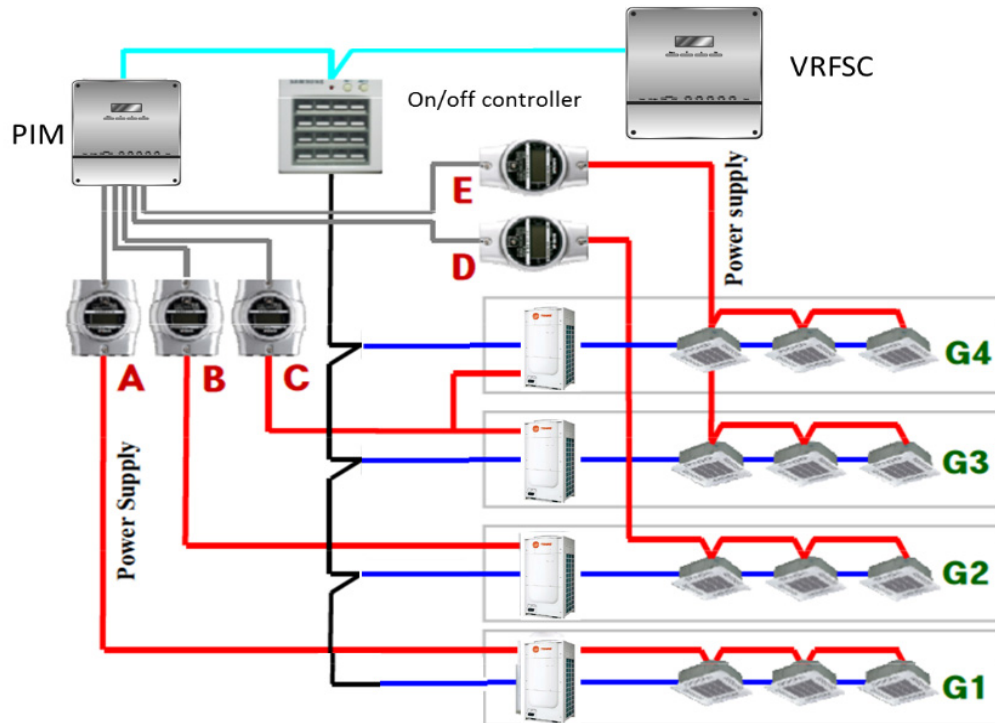

Figure 27. Typical PIM setup and power usage distribution over multiple systems (Example 1)



Indoor unit power X in G1 = Watt-hour A × $\frac{\text{Main + Fan + Stand-by capacity of indoor unit X}}{\text{Total capacity of G1}}$
Indoor unit power X in G2 = Watt-hour B × $\frac{\text{Main + Fan + Stand-by capacity of indoor unit X}}{\text{Total capacity of G2}}$ + Watt-hour D × $\frac{\text{FAN + Stand-by capacity of indoor unit X}}{\text{Total FAN/Stand-by capacity of G2}}$
Indoor unit power x in G3+G4 = Watt-hour C × $\frac{\text{Main + Fan + Stand-by capacity of indoor unit X}}{\text{Total capacity of G3+G4}}$ + Watt-hour E × $\frac{\text{FAN + Stand-by capacity of indoor unit X}}{\text{Total FAN/Stand-by capacity of G3+G4}}$

Warning : Correct watt-hour assignment is a must.

Figure 28. Typical PIM setup and power usage distribution over single systems (Example 2)

Suppose capacity values accumulated at 24:00 during one whole day is as follows.

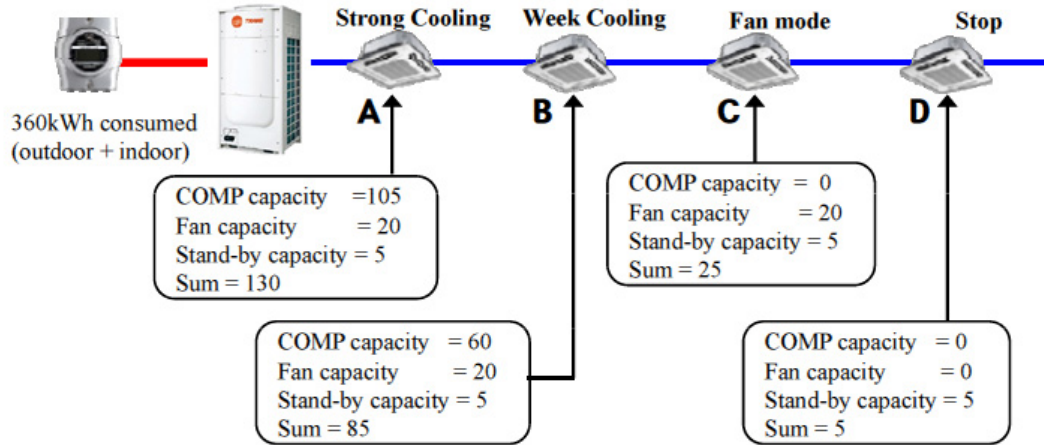

$$\text{Pd of Indoor unit A} = \frac{\text{Indoor unit capacity}}{\text{Total capacity}} \times \text{Total kWh} = \frac{130 \times 360}{130 + 85 + 25 + 5} = 192.020 \text{ kWh}$$

$$\text{Pd of Indoor unit B} = \frac{85 \times 360}{130 + 85 + 25 + 5} = 124.900 \text{ kWh}$$

$$\text{Pd of Indoor unit C} = \frac{25 \times 360}{130 + 85 + 25 + 5} = 36.735 \text{ kWh}$$

$$\text{Pd of Indoor unit D} = \frac{5 \times 360}{130 + 85 + 25 + 5} = 7.347 \text{ kWh}$$

Figure 29. Typical PIM setup and power usage distribution while in standby (Example 3)

Suppose capacity values accumulated at 24:00 during one whole day is as follows.

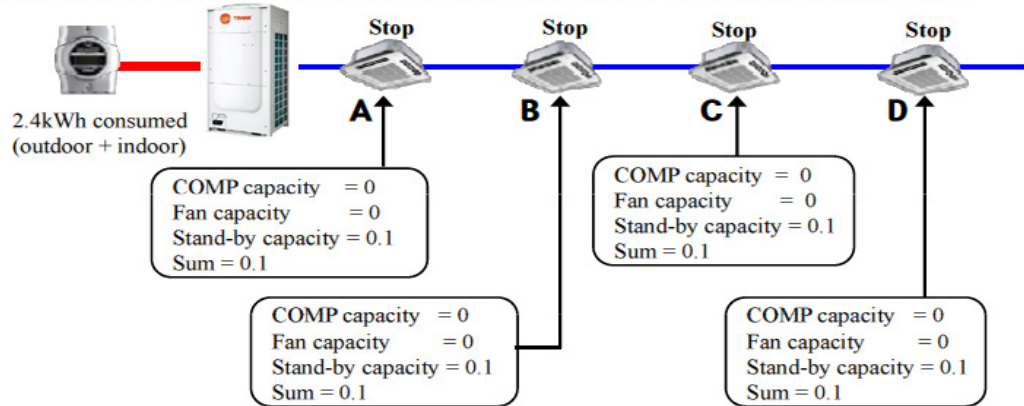

$$Pd \text{ of Indoor unit A} = \frac{\text{Indoor unit capacity}}{\text{Total capacity}} \times \text{Total kWh} = \frac{0.1 \times 2.4}{0.1 + 0.1 + 0.1 + 0.1} = 0.6 \text{ kWh}$$

$$Pd \text{ of Indoor unit B} = \frac{0.1 \times 2.4}{0.1 + 0.1 + 0.1 + 0.1} = 0.6 \text{ kWh}$$

$$Pd \text{ of Indoor unit C} = \frac{0.1 \times 2.4}{0.1 + 0.1 + 0.1 + 0.1} = 0.6 \text{ kWh}$$

$$Pd \text{ of Indoor unit D} = \frac{0.1 \times 2.4}{0.1 + 0.1 + 0.1 + 0.1} = 0.6 \text{ kWh}$$

On/Off Controller

Sixteen button on/off controller used to manually turn on/off a maximum of 256 indoor units (up to 16 indoor units per button).

Indoor Units

Terms and Definitions

Electronic Expansion Valve (EEV)

A 12 Vdc, gear driven, refrigerant metering device.

EVA_{in} Temperature Sensor

In Cooling mode, senses the refrigerant temperature after the refrigerant leaves the EEV and before it enters the indoor coil.

In Heating mode, senses the refrigerant temperature after leaving the indoor coil and before entering the EEV.

EVA_{out} Temperature Sensor

In Cooling mode, senses the refrigerant temperature after leaving the indoor coil.

In Heating mode, senses the refrigerant temperature before entering the indoor coil.

Thermo On

Used to describe the operation of an indoor unit in which the EEV is actively controlling the refrigerant flow for the purpose of comfort heating and cooling.

Thermo Off

Used to describe the operation of an indoor unit that has satisfied space temperature and therefore the EEV is closed (cooling) or at a minimum step (heating).

Air-Handling Unit (AHU) Kit

Used to convert a non-VRF indoor coil to a VRF indoor coil.

Note: *Indoor coils must be rated for heat pump operation.*

Return Air Temperature Sensor (RAT)

Senses the return air temperature at the indoor unit. Default space temperature sensor for comfort heating and cooling on all indoor units.

Notes:

- *To change the sensor to sense the space air temperature at the wired controller, change the configuration at the wired controller.*
- *The external room temperature sensor can be used as an alternative to the RAT.*

Discharge Air Temperature Sensor (DAT)

Senses the discharge air temperature on a ducted indoor unit or on an AHU kit.

Can be used for discharge air temperature control when the appropriate option code is set. Can only be set through the wired controller or the VRF System Controller.

Figure 31. Minimizing fan speed during thermo off

Mode	Thermo	EEV	Fan	"02" SEG4 setting
Cooling	ON	Open	On	0, 1, 2, 3
	OFF	Closed (0 or 35 Steps)	On	0, 1, 2, 3
			Off	4, 5, 6, 7
Heating	ON	Open	On	0
	OFF	Open 120 step	Off & On(↑) 69°F	0, 4
			Off & On (69°F↑, 20sec on every 5mins)	2, 6
		Off	1, 3, 5, 7	

"02" SEG 4	External room s/s	Minimizing fan operation
0	Disuse	Disuse
1	Use	Disuse
2	Disuse	Use-Heating
3	Use	Use-Heating
4	Disuse	Use-Cooling
5	Use	Use-Cooling
6	Disuse	Use-Both
7	Use	Use-Both

* If you set "02" SEG4 as external room s/s use, Heating compensation temperature will be set as 0°F

Low Low Fan Speed

Not user selectable. Usually seen during Auto mode/thermal off when the unit is satisfied or when a change in mode request is initiated. Seen only on cassettes which have feedback-type motors. (see Figure 10).

Auto Fan Mode

User selectable. When selected, the fan speed is determined by the ΔT between setpoint and space temperature. If less than 1.8°F from setpoint, the fan will run in low speed. If between 1.9°F and 5.3°F, the fan will run at medium speed. If greater than 5.4°F the fan will run at high speed. This logic applies to both Heating and Cooling modes of operation.

Figure 32. Auto fan speed profile

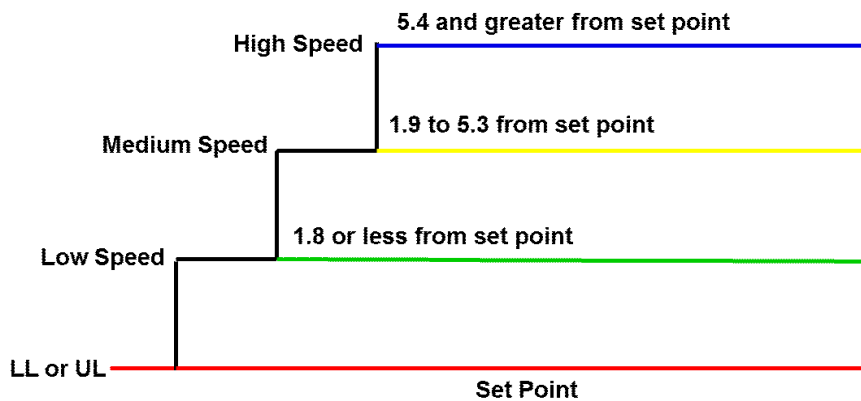

If a heat recovery system is set to Auto mode at the indoor unit, the fan defaults to Auto mode and cannot be changed. If continuous fan operation (low, mid, or high speed) is desired when the unit is in Cooling mode, the indoor unit must be set to Cooling mode. If the indoor unit is in Heating mode, the fan will *not* run continuously regardless of mode or fan setting. The unit will transition to off when the space temperature is satisfied.

Operating Modes

Cooling Mode

In Cooling only mode, the fan can run in aAuto fan mode. It will follow the same fan profile as for Auto operating mode. If high, medium or low fan speed is required while actively cooling the fan will run continuously in the set speed while the indoor unit is thermo on and while it is thermo off.

Heating Mode

In Heating only mode, the fan can run in aAuto fan mode. It will follow the same fan profile as auto. If high, medium, or low fan speed is required while actively heating, the fan will run continuously while the indoor unit is actively heating. Unlike cooling only mode, in heating only mode the fan will transition to off when the space temperature satisfies the space temperature setpoint. This is because the EEV on a HP or HR unit is always open to between 80-230 steps in heating mode. On a HR unit, the heating solenoid in the MCU is also open anytime the indoor unit is in heating mode (thermo on or thermo off) and the outdoor unit is actively attempting to satisfy capacity requirements. Because of the solenoid being open on the MCU, the risk of overheating the space exists due to refrigerant flow through the indoor coil.

Dry Mode

Dry mode is user selectable and the fan speed will run in low or LL/UL speed in order to dehumidify while operating in the cool mode.

Turbo Mode

Note: High wall indoor units only.

Turbo is user selectable through the wireless remote control only.

- Once selected it will increase fan speed to High or Turbo for 30 minutes maximum in heating or cooling. When that time has elapsed, the system will return to its previous control method.
- If turbo is selected while in quiet mode, it will cancel quiet mode.
- You will be unable to change setpoint during Turbo mode.

Auto Mode (Auto Changeover)

Heat Recovery

Auto mode for a heat recovery indoor unit will change between heat and cool modes and cool to heat modes based on the space temperature relationship to setpoint. (Refer to [Figure 33](#) and [Figure 34, p. 40.](#))

- Auto Heat to Auto Cool: If the indoor unit is in heat mode and the space temperature is above the setpoint 1.8°F for 5 minutes (default setting) the indoor unit will change to cool mode.
- Auto Cool to Auto Heat: If the indoor unit is in cool mode and the space temperature is below the setpoint 1.8°F for 5 minutes (default setting) the indoor unit will change to heat mode.

Indoor Units

Figure 33. Heat recovery auto changeover logic

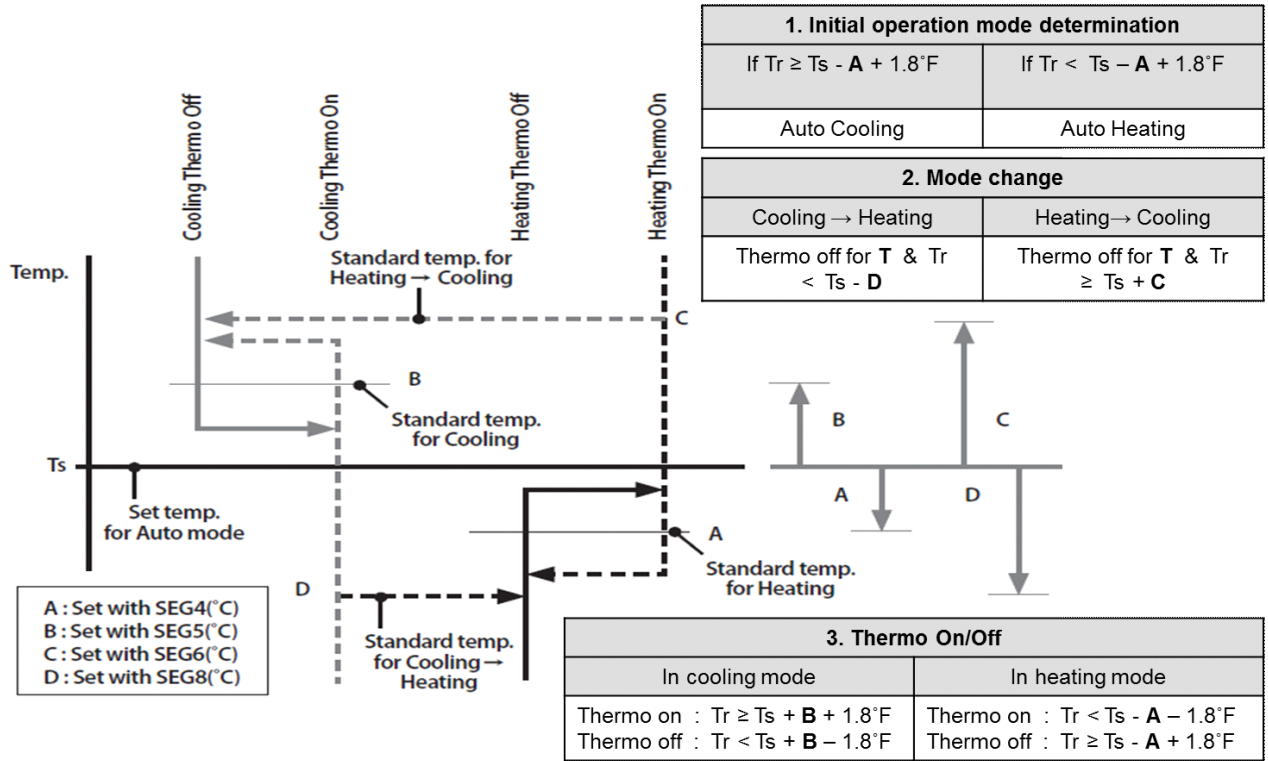
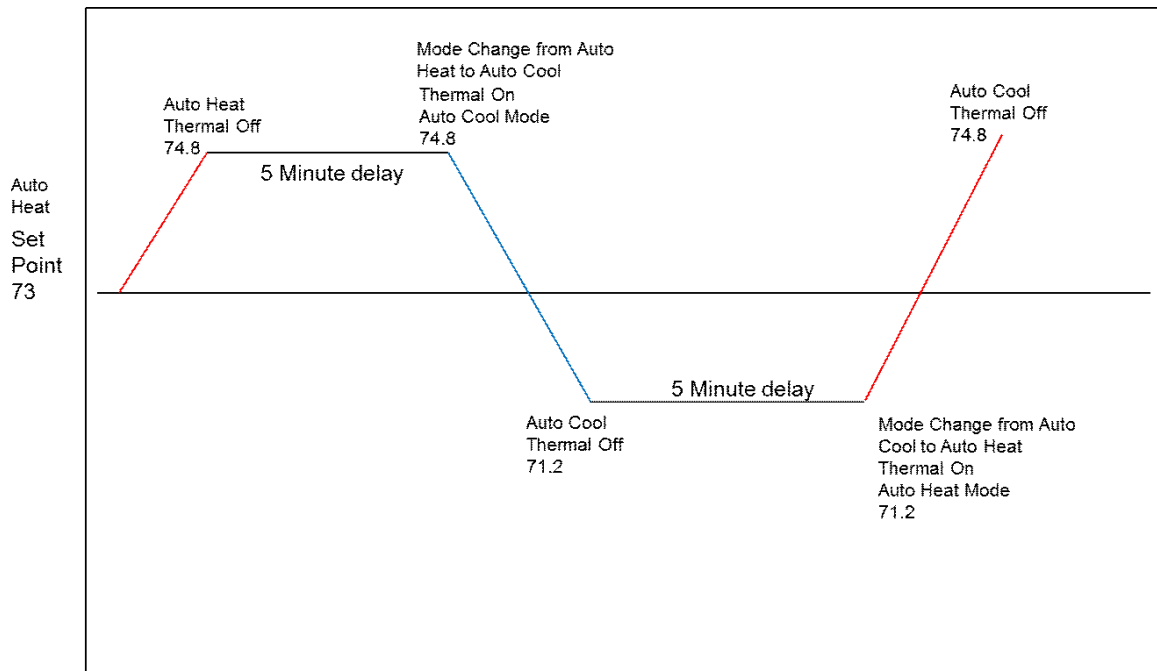

Figure 34. Heat recovery auto changeover logic example



Heat Pump

Auto mode for a 1-to-1 application heat pump system (one outdoor unit and one indoor unit) will change between heat and cool modes and cool to heat modes based on the space temperature relationship to setpoint. To enable this function, increment the product option code digit 5 by 2. After the setpoint is satisfied, the indoor unit must be in thermo off for 30 minutes before mode change is possible.

Note: Auto mode changeover will not work if more than one indoor unit is connected to a heat pump system.

Figure 35. Heat pump system auto changeover

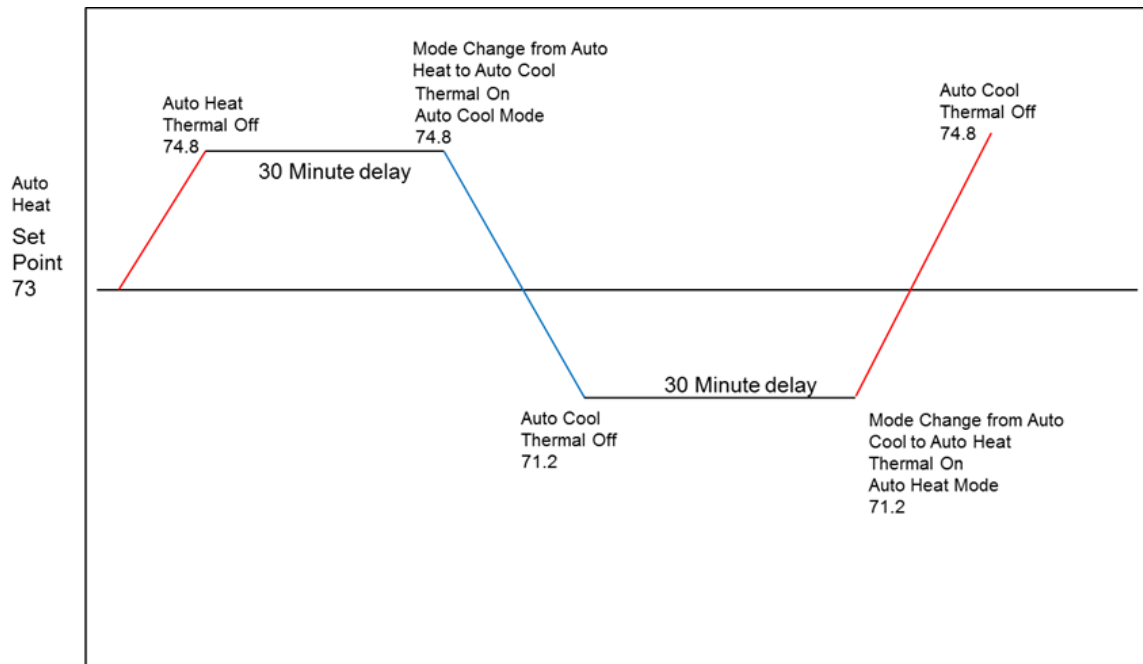

Special Operations

Oil Recovery

The EEV will open to a predetermined position based on indoor unit operation when an oil recovery mode is initiated. If the unit is off, the fan will remain off during the oil recovery cycle. If the indoor unit is actively heating or cooling, the fan will run as it was prior to entering the oil recovery cycle.

Defrost

During a defrost cycle the fan shuts off until the cycle is complete. The fan will remain off once heating is re-initiated and the coil temperature reaches a temperature that will prevent cold air from blowing where it is not desired.

Discharge Air Control

Ducted indoor units and units that have AHU kits installed are the only indoor units that allow discharge air control. While the indoor unit is actively heating or cooling, the end user can set a discharge air temperature setpoint and a space temperature setpoint. The thermal on/thermal off of the unit will be based on the desired space temperature setpoint relationship to the space temperature while the discharge air setpoint is met. To use this function either a wired controller or a VRF System Controller will be required (refer to the IOM for specific details).

For ducted indoor units only, while the indoor units are operating in cool or heat mode, the EEV and fan will adjust to meet the discharge air setpoint temperature while maintaining space temperature setpoint.

For an AHU kit installed on an indoor unit, while the indoor units are operating in cool or heat mode, the EEV will adjust to meet the discharge air setpoint temperature while maintaining space temperature setpoint. Fan control is not possible when using an AHU kit applied to an indoor unit. You will only have on/off control with an AHU kit.

The difference between discharge air temperature and discharge air setpoint temperature will not start the thermal on/thermal off operation of the indoor unit. The space temperature setpoint will start and stop the unit. The space temperature setpoint for heating or cooling can be adjusted in whole numbers to between 64°F and 86°F. The target discharge air setpoint can be adjusted between 46°F and 64°F for cooling mode and between 86°F and 109°F for heating mode using a wired controller or VRF System Controller.

Note: External condition or protective logic may not allow for the discharger air control to satisfy the discharge air temperature setpoint.

Heating Temperature Compensation

The heating temperature compensation is set by the product option code as default. If a different setting is desired, a change to digit 21 of the installation option code is required. If using an external room sensor, then digit 4 of the installation option code has been set to reflect that, it will override the factory default and digit 21 settings.

Figure 36. Heating temperature compensation process

✓ $\Delta T^{\circ}\text{C}$ (= Heating compensation temperature)

1. Factory default when using return temp sensor

- 1) 4way type : $\Delta T = 9^{\circ}\text{F}$
- 2) others : $\Delta T = 3.6^{\circ}\text{F}$

2. Installation setting(installation option code SEG21)

SEG21 Setting	$\Delta T^{\circ}\text{F}$
0	Factory default
1	3.6°F
2	9°F

3. When using external room temp. sensor(Installation option SEG4 = 1) it will disable the factory default and override the factory default and the installation option code digit 21 settings.

: $\Delta T^{\circ}\text{F} = 0^{\circ}\text{F}$

※ Priority : Ext. Room Sensor setting > Installation option setting > Factory Default
(If higher priority setting is applied, lower will be ignored.)

Indoor Unit Freeze Up Protection

This function is to prevent an indoor unit from freezing up.

- If any EVA_{in} temperature is lower than 35°F for 40 seconds, the outdoor unit will hold the compressor hertz at the current speed.

- If any EVA_{in} temperature less than 32°F for 40 seconds, the compressor hertz will be reduced by 10%.
- If, after 2 minutes, the problem EVA_{in} temperature returns to 39°F, the outdoor unit will return to normal control. If any EVA_{in} temperature is between 32°F and 39°F, the compressor hertz will hold. If any EVA_{in} temperature continues to be less than 32°F after 2 minutes, the hertz will be reduced by 5 hertz.
- If any EVA_{in} temperature is less than 28°F for 40 seconds, the outdoor unit will stop until the EVA_{in} temperature is greater than 39 for 2 minutes.

Defrost

During the defrost cycle the indoor units will reverse cycle from heat to cool and the fan will stop, which prevents the indoor unit from blowing cold air into the space. The EEV will go to a predetermined step. If an indoor unit is in the thermal off state, the EEV will open to 400 steps. If the indoor unit is actively heating, the EEV will open to 480 steps.

Oil Recovery

During an oil recovery cycle, the indoor unit EEV will open to a minimum of 400 steps in cooling mode and 300 steps in heating mode. If the operating units have EEVs that are open more than the minimum amount, the EEVs will remain under normal control.

Accessories

Drain Pump

The drain pump will be energized if the indoor unit is actively operating in cool mode, auto cool, or dry mode. (See indoor unit IOM installation option codes for selectable pump settings). When the indoor unit is satisfied the pump will shut off based on the installation option setting.

While the indoor unit is running in auto cool, cool, or dry mode, the drain pump will always be energized to run. The first time the float switch opens, an error code 702 will appear on the outdoor unit and associated controller(s). If the float switch is open for more than 60 seconds, an error code 153 will result and the associated indoor unit will shut down until the error is cleared. The rest of the system will continue to run.

Figure 37. Drain pump operation

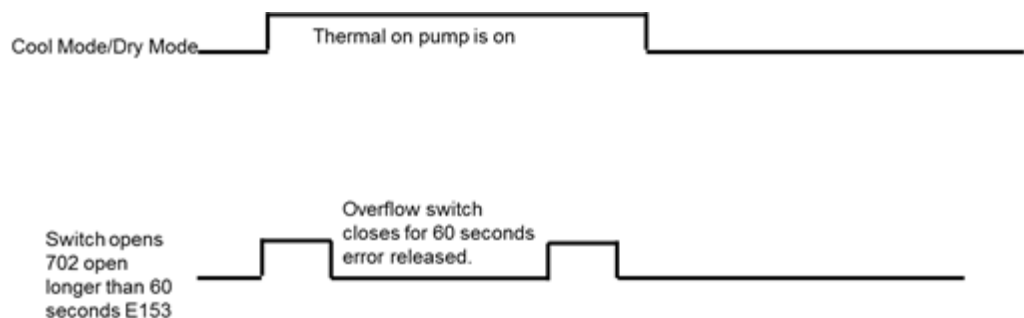

While the indoor unit is in auto heat mode, heat mode, fan mode, or thermal off state, the pump will be off. While off, if the float switch opens, the pump will run for 3 minutes to clear the drain pan of any condensation. If the float switch reopens within 60 seconds after that, the indoor unit will display error code (E153). The rest of the system will continue to operate. (Refer to [Figure 38, p. 44.](#))

Figure 38. Heating and fan mode drain pump operation with error code

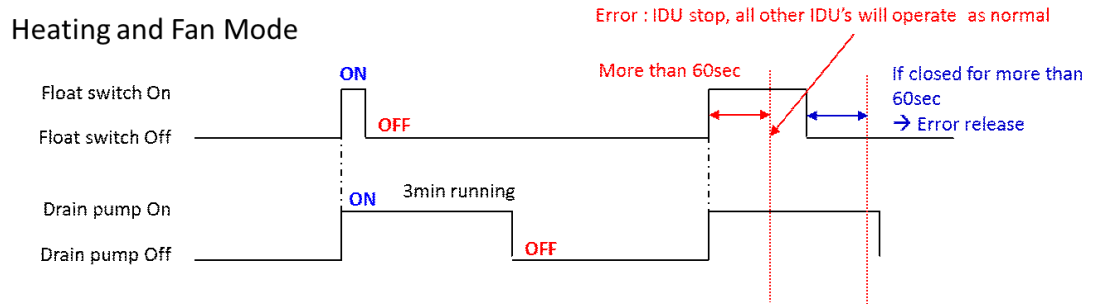

Louver Operation on Cassette Units

Cassette units have louvers that can be changed to a fixed position to prevent the discharge air from blowing directly on a person. The swing function allows the louvers to oscillate up and down to help mix the air and to prevent air from blowing on a person any time the unit is operating.

Motion Detector on Mini 4-Way Cassette Units

This device contains a sensor that causes the unit to cycle off if no motion is detected within the specified time period set for installation option code, digit 23.

Standard Mode

If no motion is detected after the specified number of “soft off” minutes elapses, the unit will turn off. If motion is detected before the specified number of “hard off” minutes elapses, the unit will restart. If the unit shuts off after reaching the hard off time limit, the unit must be manually restarted. Refer to [Table 2](#).

Table 2. Mini 4-way cassette motion detector timer options descriptions

OFF Function Description		
Soft OFF	Turns off indoor unit but can restart with motion detection before HARD OFF.	
	System:	OFF
	MDS:	ON
	Auto ON:	ON
Hard OFF	Turns unit off but will not turn back on after motion is sensed. Unit will need to be manually powered ON.	
	System:	OFF
	MDS:	OFF
	Auto ON:	OFF

Premium Mode

This mode functions the same as standard mode with the following exceptions. Refer to [Table 3, p. 45](#).

- **Comfort Flow:** When the motion sensor detects motion, the blade direction adjusts to prevent air from blowing directly on anyone in the room.
- **Comfort Temperature:** When the temperature difference between the upper and lower areas of a room is extreme, the blade direction lowers to mix the air, which reduced the temperature difference and makes the air temperature more comfortable.
- **Comfort Saving:** When motion is not detected and a hard off occurs, the maximum cooling increase is 3.6°F from current setpoint; the maximum heating decrease is 3.6°F from current setpoint.

Table 3. Mini 4-way cassette motion detector: digit settings for timer options

Digit	Set digit to...	Function		
		Mode	Soft Off (minutes)	Hard Off (minutes)
23	0	Disabled (factory default)		
	1	Standard	20	30
	2		40	60
	3		80	120
	4		120	180
	5	Premium	20	30
	6		40	60
	7		80	120
	8		120	180

Note:
Standard mode: If no motion is detected after the specified number of Soft Off minutes elapses, the unit turns off. If motion is detected before the specified number of Hard Off minutes elapses, the unit restarts. If no motion is detected before the specified number of Hard Off minutes, the unit must be restarted.
Premium mode: The function in this mode is the same as standard mode. The following control logic is activated:
Comfort flow: The motion sensor adjusts blade directions when motion is detected to prevent air flow from blowing directly onto a person.
Comfort temperature: When the temperature between the upper and lower areas of a room is extreme, the blade direction is lowered to mix the air to reduce the temperature difference.
Comfort saving: When motion is detected, the maximum cooling increase is 3.6°F, the maximum heating increase is 3.6°F.

External Contact Control Board

This accessory can be used in many situations. Three examples are provided below. All uses of the external contact control board require a specific installation option code setting. The terminals are rated at 250 Vac, 3 A.

- **Error-reporting terminals:** Terminals 1 and 2 can be used as an error reporting signal. When the indoor unit is energized, these contacts will be closed and will open if an error occurs at the indoor unit. There is no voltage at these terminals (dry contacts).
- **Interlocking terminals:** Terminals 3 and 4 can be used to interlock other devices such as but not limited to ERVs, dampers, exhaust fans, and auxiliary heat relays. There is no voltage at these terminals (dry contacts). These terminals can be used to close when the indoor unit is powered up or when the unit is actually heating or cooling, depending on the installation option code setting. Please refer to the indoor unit IOM. (Refer to [Figure 39](#).)
- **Shutdown terminals:** Terminals 5 and 6 can be used for either a start/stop or a stop operation that would require a manual reset. This operation is dependent on the installation option code setting for digits 14 and 15.

Figure 39. Interlocking terminals using the External Contact Control Board

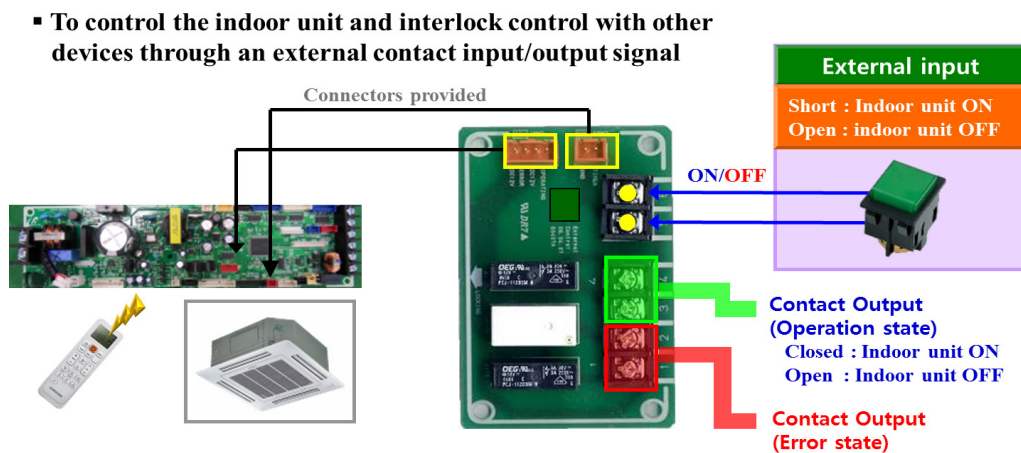

External Contact Control Board Used for Auxiliary Heat Operation

A secondary heat source maybe needed on some systems. For the use of auxiliary heat, all indoor units require an external contact control board. To enable this function, a specific installation option code is required to be set that will allow auxiliary heat to turn on. In addition, a specific temperature offset and designated time period can be set (refer to the external contact control board IOM).

Important: At this time the use of electric heat is not allowed in the supply duct of any indoor unit.

Multi-Tenant Control Board

If power is interrupted to any indoor unit, the entire system will shut down within 3 minutes. This control function prevents the entire system from shutting down if power is lost to an indoor unit. It will allow the communications from the affected indoor unit to be active while power is interrupted. By powering the 24 V step-down transformer from an independent power source, the transformer can power the multi-tenant function controller. This allows 12 Vdc to the V1/V2 terminals on the indoor unit main control board. It also provides 5 Vdc to the download plug on the main control board of the indoor unit. This will prevent the system from shutting down during an unexpected power loss to an indoor unit. Each indoor unit requires its own multi-function control board.

Figure 40. Multi-function control board wiring diagram

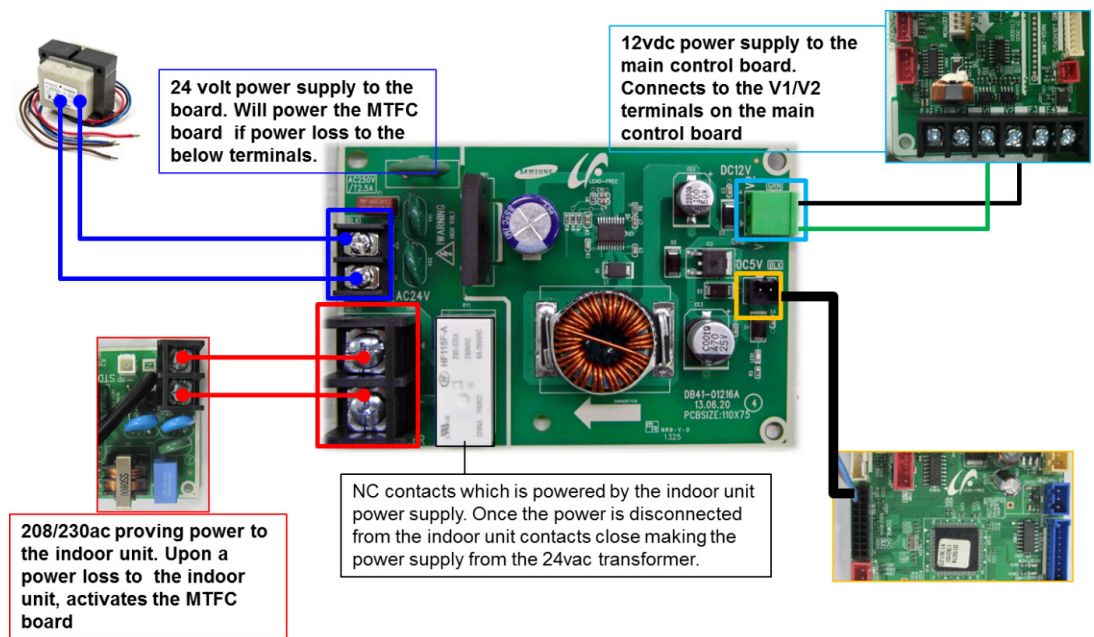

Mode Change Unit (MCU)

This unit applies only to heat recovery (HR) systems.

Component Identification

1. **Cooling solenoid**—Energizes on a call for cooling from the indoor unit
2. **Heating solenoid**—Energizes on a call for heating from the indoor unit
3. **MCU EEV (equalizing EEV)**—Opens to equalize the pressure during mode change of an indoor unit. Opens to 480 steps during cooling mode. Closed during mainly cooling mode.
4. **Sub-cooling loop**—Provides extra sub-cooling at the MCU during certain conditions
5. **Sub-cooling EEV**—Controls the sub-cooling with in the MCU
6. **MCU liquid bypass valve**—Opens to allow for extra sub-cooling within the MCU. Also opens to flush the MCU of oil during partial operation of indoor units
7. **Sub-cooling temperature sensors**—Measures the sub-cooling loop, refrigerant temp in and refrigerant out

Figure 41. MCU cycle diagram showing components

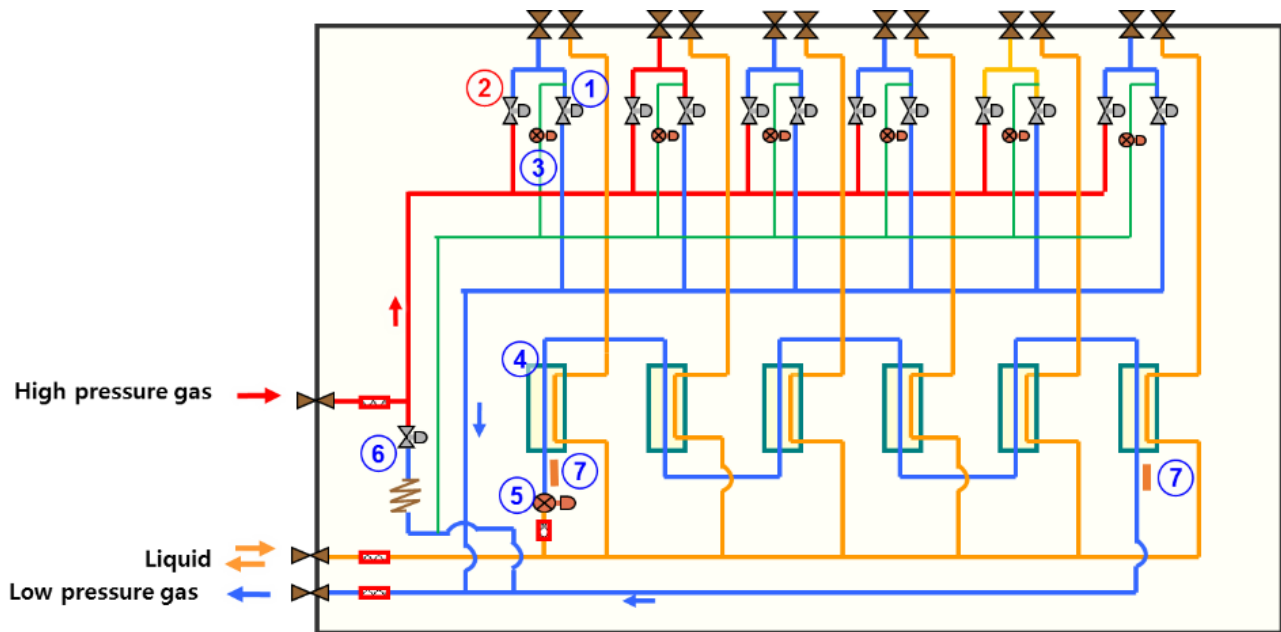

Mode Change Unit (MCU)

Figure 42. Component identification

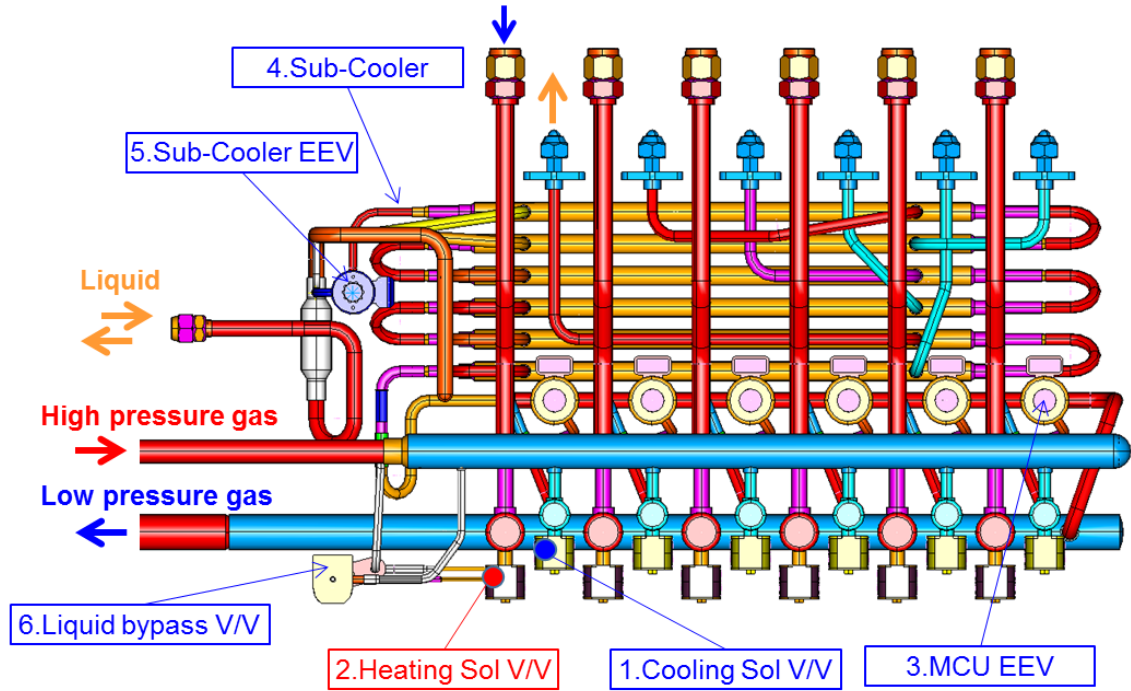

Modes of Operation

Figure 43. Cooling

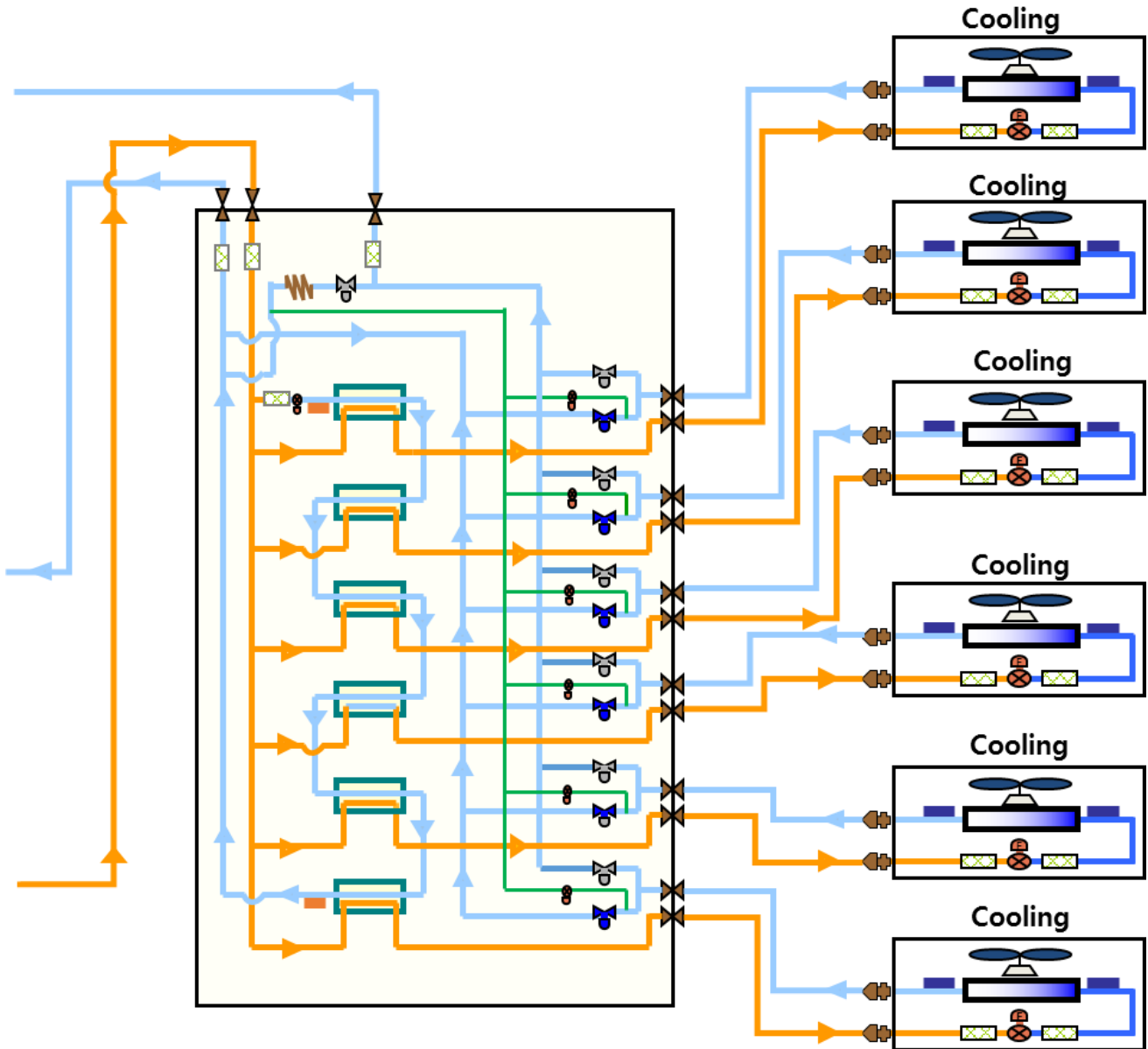

Figure 44. Heating

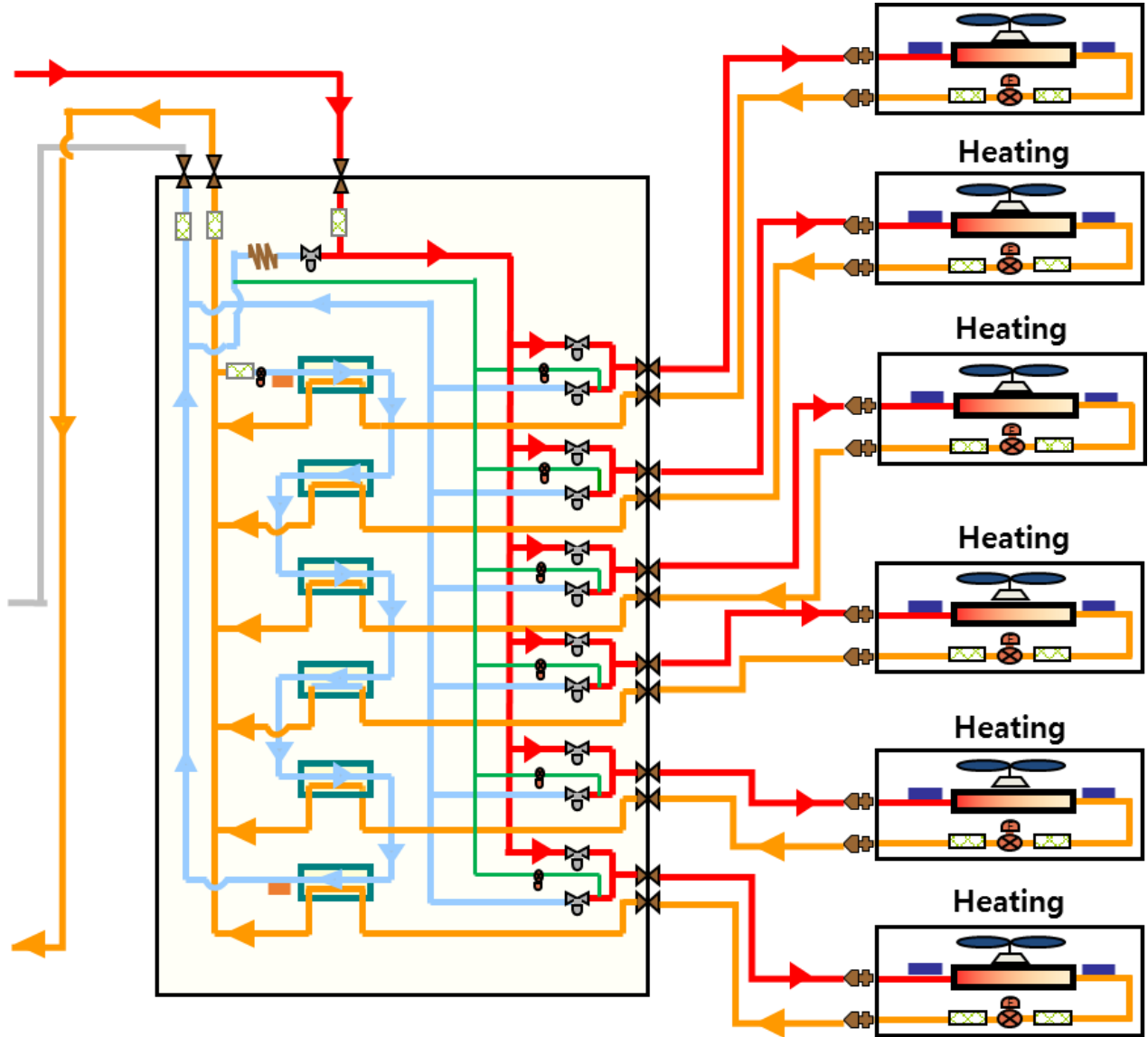

Figure 45. Mainly Cooling

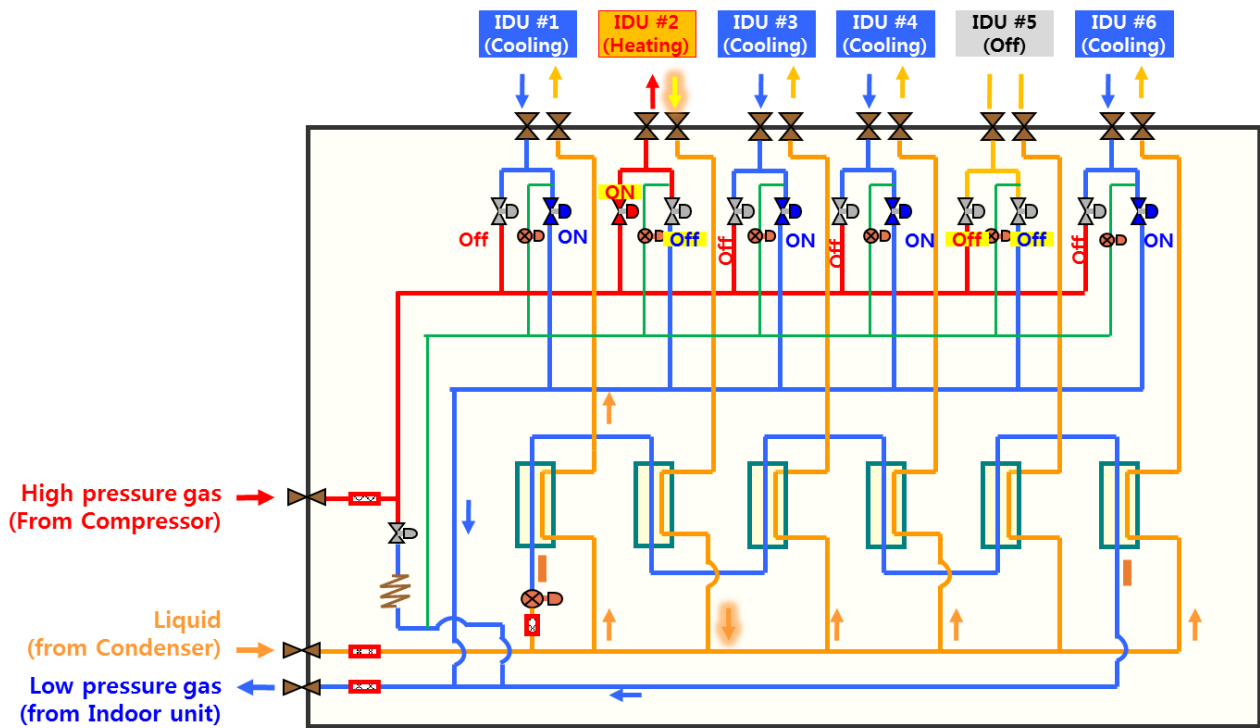
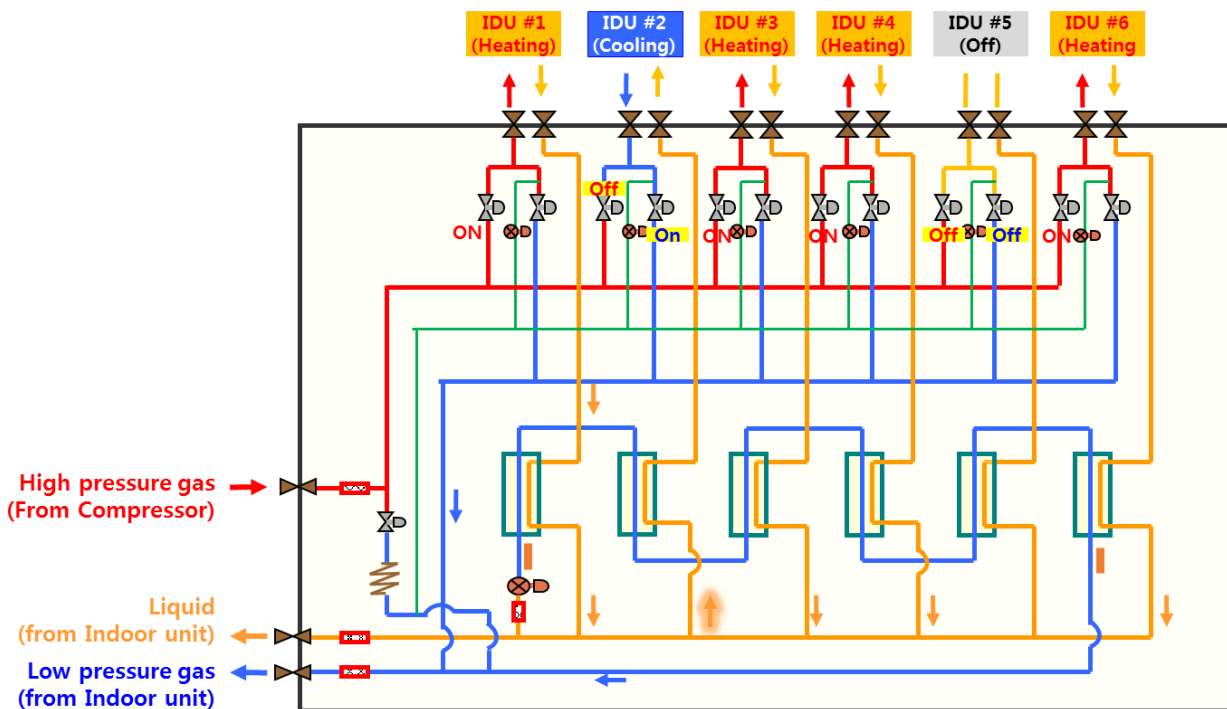

Figure 46. Mainly Heating



MCU Sequence of Operations

MCU EEV (equalizing EEV)

A 480-step EEV that is open when the system is off, open in cooling mode, and closed in heating mode. An MCU EEV is on each MCU port. Each MCU EEV that is properly addresses will function as follows:

- Used to equalize pressure in the system while the system is off.
- Used to minimize noise generated during mode change from heating to cooling.

Heating Solenoid Valves

Opens to allow hot gas refrigerant to flow through the indoor unit coil in heating mode. Valve is always energized in heat mode, even if the indoor unit itself is thermal off. This heating solenoid valve allows the flow of refrigerant through the coil to prevent hoarding of oil and refrigerant.

This valve is also used during the "all cooling mode" to help maintain the mass flow rate of refrigerant back to the compressor. When used for this reason, the HGBP2 is also open.

Cooling Solenoid Valves

Opens to allow low-temperature, low-pressure refrigerant to exit the indoor unit in the cooling mode. This cooling solenoid valve is energized anytime the indoor unit is energized in cooling mode and actively cooling (thermal on).

Subcooling Loop

The subcooling loop is used to secure optimal subcooling to the indoor unit units. It is active only during main cooling or main heating operation.

While mainly heating, the refrigerant will leave an indoor unit that is heating as a high-pressure liquid that travels through the subcooler to be subcooled. After being subcooled, the refrigerant is available for use by an indoor unit requesting cooling. This process increases performance of the system and helps to reduce noise within the MCU that serves an indoor unit that is requesting cooling.

While mainly cooling, the refrigerant will leave an indoor unit that is cooling as a low-pressure, low-temperature gas that travels through the subcooler as the subcooling medium used to increase the subcooling of the refrigerant that is going to be used by an indoor unit in cooling mode. Upon leaving the subcooling loop, the refrigerant suction gas is returned to the compressor.

Subcooling EEV

Serves multiple purposes. It controls subcooling across the subcooling loop. The superheat across the subcooling loop is what drives the valve to open and close. Superheat across the subcooling loop is measured using the MCU subcooling loop in/out temperature sensors.

Opens periodically to flush oil and refrigerant from the MCU during low or no capacity request from the indoor units connected to that MCU.

Liquid Bypass Valve (LBV)

Prevents refrigerant from being trapped in the high-pressure gas pipe. It utilizes several logic-based routines to judge when this refrigerant accumulation is most likely to happen.

When all heating solenoids in the MCU are de-energized for 30 minutes continuously, the valve will open for 10 seconds. This routine will run during mainly cooling, mainly heating, and heating only mode(s).

During cooling only mode, 5 minutes after release from safety start, the LBV opens for 1 minute.

During cooling only mode, if the system has been operating for more than 1 hour, the LBV opens for 3 minutes and then resets the 1 hour timer.

If the compressor shuts down to change modes or if the system is satisfied and shuts off, the LBV opens for 5 minutes.

The LBV opens for 5 minutes every 15 minutes while operating in cooling mode.

The LBV is open for 1 minute when a changeover from mainly cooling to mainly heating is executed.

Subcooling Sensor

Used to determine ΔT between the in and out temperature of the subcooling loop. Resulting temperature drives the subcooling EEV open or closed accordingly.

Low Ambient Cooling

Any unit between 18 MBh and 30 MBh that will be used for cooling down to 5°F, requires that the Y-joints provided with the MCU are used. By combining two ports and feeding the indoor unit, adequate refrigerant is supplied to the indoor unit during low ambient conditions. The outdoor unit option 12 setting (expand temperature operational range in cooling mode) must be changed as well to ensure proper operation.

Outdoor Unit

Definition of Terms

Heat Pump (HP)

Two pipe, heat only, or cool only variable refrigerant flow (VRF) HVAC system.

Heat Recovery (HR)

Three pipe, simultaneous heating and cooling variable refrigerant flow (VRF) HVAC system.

Cooling

Refers to a VRF system in which the mode of operation is cooling for all indoor and outdoor units. Applies to both HP and HR systems.

Mainly Cooling

Refers to a VRF system in which the mode of operation is cooling for all outdoor units and the majority of indoor units, while at least one indoor unit is operating in heating mode. Applies to HR only.

Heating

Refers to a VRF system in which the mode of operation is heating for all indoor and outdoor units. Applies to both HP and HR systems.

Mainly Heating

Refers to a VRF system in which the mode of operation is heating for all outdoor units and the majority of indoor units, while at least one indoor unit is operating in cooling mode. Applies to HR only.

High Pressure, High Temperature Gas

Discharge gas leaving the compressor.

High Pressure, High Temperature Liquid

Condensed refrigerant.

Low Pressure, Low Temperature Gas

Suction gas returning to the compressor.

Inverter Compressor

Single or dual inverter driven scroll compressors depending on unit size and voltage. Standard operating frequency range is between 20–140 Hz. The frequency of the compressor changes based on indoor unit capacity requests. A capacity request from an indoor unit is required to turn on a compressor. In special situations, it will turn down to 14 Hz after being initiated. Compressor(s) run continuously until all indoor unit capacity requests are satisfied.

Vapor Injection

Boosts heating capacity of the compressor by 20%. Maintains mass flow rate of refrigerant in cooling mode at start up and helps to maintain suction pressure.

Outdoor Fan

Modulating inverter-driven fan motor utilized on air-cooled units. The number of outdoor fans will depend on the tonnage and voltage of the unit.

Cooling Mode

The fan is driven by the high-pressure sensor. As the compressor discharge pressure increases, the fan speeds up. As the discharge pressure decreases, the fan slows down. Default target high pressure in cooling mode is 355 psig.

Heating Mode

The fan is driven by the low-pressure sensor. As the outdoor air (OA) temperature changes, the fan will speed up or slow down to maintain a target low pressure. Target low pressure is dependent on OA temperature. As the OA temperature decreases, so will the target low pressure, and vice versa. As the OA temperature increases, so will the target low pressure.

Heat Exchanger (HX)

Allows for the transfer of heat. Air-cooled units use tube and fin heat exchangers. Water-cooled units use brazed plate heat exchangers.

Cyclone Oil Separator

Used to separate oil from the refrigerant at the discharge of the compressor. On a two-compressor model, oil is returned to the common suction line of the compressors.

Accumulator

Protects the compressor from liquid refrigerant flooding by separating liquid refrigerant from gas refrigerant. As the refrigerant boils off, the accumulator allows refrigerant to enter the compressor as a vapor.

Accumulator Oil Return Valve (ARV)

Prevents liquid refrigerant from flowing directly to the compressor while it is stopped or during the initial start-up process. When the compressor is running in normal operation, the ARV opens to allow oil return to the compressor from the accumulator or return valve.

Intercooler

Secures up to 36°F of sub-cooling for liquid refrigerant used during cooling mode. Secures up to 3.6°F superheat for use during vapor injection to the compressor in heating mode.

Refrigerant Cooled Heat Sink (IPM)

Utilizes liquid refrigerant to cool the insulated-gate bipolar transistor (IGBT) on the compressor inverter board(s).

Crankcase Heaters

Drives refrigerant from the compressor sump. Used during cold start to help secure a discharge superheat (DSH) of 18°F at start up.

High Pressure Sensor

Utilizes a 0–5 Vdc signal to report compressor discharge pressure to the main control board. This allows for control of the outdoor unit fan motor in cooling mode and of compressor operation in heating mode. Also used as a secondary safety to the high pressure switch to aid in the prevention of a high-pressure situation.

Low Pressure Sensor

Utilizes a 0–5 Vdc signal to control the compressor speed in the cooling operation and the OD fan motor in heating mode.

High Pressure Switch

Primary device used to prevent high pressure situations. Opens at 650 psi. Resets at 575 psi.

Main EEV

Refrigerant metering device used in heating mode for the air-source and the water-cooled outdoor units.

- The main EEV is fully open in cooling mode. The main EEV is closed when the unit is stopped.
- In mainly cooling mode (HR only), the main EEV is used as a regulating device to force high-temperature, high-pressure refrigerant through the main cooling valve. The amount of refrigerant needed for heating during the mainly cooling mode will dictate how much the main EEV is open/closed.

Electronic Vapor Injection Electronic Expansion Valve (EVI EEV)

Metering device used to regulate subcooling and superheat in heating mode through the intercooler refrigerant circuit.

Cooling Mode

Target subcooling is 36°F across the intercooler. By opening or closing the EVI EEV, the ΔT across the intercooler will rise or fall to meet the target system subcooling. As a result of keeping the target subcooling at approximately 36°F, the proper refrigerant temperature for vapor injection will be maintained.

Heating Mode

Target superheat (SH) during vapor injection is 3.6°F across the intercooler to the compressor (EVI EEV energized). If SH is above 3.6°F, the EVI EEV will open more to reduce the SH. If the SH is below 3.6°F, the EVI EEV will close down to increase SH.

Target superheat (SH) in EVI bypass mode (EVI EEV de-energized) is 18°F and a compressor discharge temperature of 194°F.

For Increased Compressor Reliability

If the compressor discharge temperature is abnormally high, the EVI EEV will open to decrease the discharge temperature.

Electronic Vapor Injection (EVI) Bypass Valve

The EVI bypass valve opens anytime the EVI solenoid valve is closed. The open EVI bypass valve allow refrigerant to recirculate back to the suction side of the compressor through the accumulator while maintaining adequate subcooling through the intercooler. In EVI bypass mode, target superheat is 18°F.

Electronic Vapor Injection (EVI) Solenoid Valve

The EVI solenoid valve is used to maintain mass flow rate during compressor operation at start-up and during heating mode. Refer to [Figure 47, p. 57](#).

- At start-up, the EVI bypass valve closes and the EVI solenoid valve opens to ensure that the compressor is supplied with sufficient refrigerant to operate safely. Typically, the EVI solenoid valve will close 5-8 minutes after start-up.
- In the heating mode, the EVI bypass valve closes and the EVI solenoid valve opens to boost heating capacity by up to 20% in low ambient, low-load conditions.
- Also, the EVI solenoid valve helps to equalize suction pressure between operating outdoor unit modules (T_{out} is 96°F cooling/50°F heating).

Figure 47. EEV operation for heating and cooling mode

- ✓ Purpose
- To increase sub-cool of system : Sub-cool ↑ → Efficiency ↑

Valve	EVI Bypass mode	EVI On mode (Vapor Injection)	EVI Off mode
1 EEV	Open	Open	Close
2 Sol	Open	Open	Open
3 Bypass	Open	Close	Open
*Condition	Normal	All comp 60hz ↑ Tout < 96°F(c)/50°F(h)	Safety start

EVI mode	EVI Bypass mode	EVI On(Vapor Injection) mode
Cooling	▷ Sub-cooling control : 36°F (High pressure Saturated temp. – Liquid tube temp.) 	▷ SH(EVI out temp. – EVI in temp.) control : 3.6°F If main EEV SH is lower than target SH, EVI SH is 9°F
Heating	▷ SH control EVI out temp. – EVI In temp. : 50°F	
Remark	※ If comp discharge temp. is abnormally high, the EEV will open to decrease the discharge temperature	

Mainly Cooling Valve

Used in mainly cooling mode to allow hot gas to flow the mode change unit (MCU)/indoor unit in order to satisfy indoor unit(s) request for heating.

Hot Gas Bypass Valve 1 (HGBP1)

Used to compensate for an abnormally low suction pressure condition. On during **Safety Start**. On during low pressure protection control.

Valve Position	Cooling (psi)	Heating (psi)
Off	59	34
On	45	19

Hot Gas Bypass Valve 2 (HGBP2)

Note: Applies to heat recovery units in cooling only mode.

When open, it increases the suction line volume back to the compressor by allowing the low pressure, low temperature gas line and the high pressure, high temperature gas line to be "combined."

Opens to equalize refrigerant pressure between the high pressure and low pressure gas lines when the system is stopped. This function increases the volume of refrigerant being brought back to the compressor, which reduces pressure drops due to long line lengths.

4-Way Valve

Diverts refrigerant flow based on mode of operation. Energizes to heating mode and de-energizes to cooling mode.

Outdoor Unit

Cooling Mode

Diverts high-pressure, high-temperature gas to the heat exchanger for condensing.

Heating Mode

Diverts high-pressure, high-temperature gas to the MCU/indoor units.

Outdoor EEV Bypass Solenoid Valve

Valve closes in the mainly cooling mode, which forces high-pressure liquid through the main EEV. This valve is energized only in cooling mode.

Outdoor EEV Bypass Check Valve

Allows for flow in one direction through the EEV bypass solenoid valve.

Discharge Check Valve

Prevents discharge from an online compressor from entering the discharge line of an off-line compressor.

Heat Recovery (HR) Check Valve

Prevents high-pressure gas from entering the suction line through the 4-way valve.

Discharge Temperature Sensor (DTS)

Measures the temperature of the refrigerant as it leaves the compressor. The measurements are used to protect the compressor from damage by holding at or reducing capacity, up to and including shutdown, when a high discharge temperature is sensed.

212°F	221°F	230°F	248°F
Hz hold	Hz down by 10%	Capacity reduced by 10%	Units shuts down (E416)

Suction Temperature Sensor (STS)

Measures the temperature of the suction gas returning to the compressor.

Condenser (HX) Out Temperature Sensor

Measures the temperature of the refrigerant leaving the condenser in cooling mode. Also, used as an input to terminate defrost mode.

EV_{in} and EV_{out} Temperature Sensor

Measures the temperature across the intercooler. Provides a reference for target superheat.

Liquid Tube Temperature Sensor (LTT)

Measures the liquid line temperature after the intercooler.

Compressor Top Temperature (CTT)

Temperature reference for the dome of the compressor.

- Input is utilized to help diagnose under or overcharged system(s).
- Input is utilized to prevent damage to the compressor.

These measurements are used to protect the compressor from damage by holding at or reducing capacity, up to and including shutdown, when a high compressor top temperature is sensed.

221°F	230°F	239°F	248°F
Hz hold	Hz down by 10%	Capacity reduced by 10%	Units shuts down (E416)

Outdoor Temperature Sensor (ODT)

Senses the outdoor temperature. Used as a reference for:

- Heating mode lockout: 86°F for heating mode.
- Commissioning mode: 14°F to 104°F. Above 50°F, it will commission in cooling mode. Below 50°F, it will commission in heating mode.

Service Valves

Heat pump and heat recovery units have a liquid and suction gas isolation valve. Heat recovery units will also have a discharge gas isolation valve.

Discharge Superheat (DSH)

Discharge superheat is the difference between Compressor Discharge Temperature (CDT) and High Pressure Saturated Temperature (HPST) → $DSH = CDT - HPST$.

Subcooling Control (SC)

Used to increase efficiency of the VRF system by modulating the EVI EEV to maintain a difference between High Pressure Saturated Temperature and Liquid Tube Temperature ($SC = HPST - LTT$). Optimal system subcooling is 36°F.

Superheat (SH)

Superheat is the difference between Suction Temperature and Low Pressure Saturated Temperature ($SH = ST - LPST$).

Superheat Control

Modulation of the EVI EEV is used in heating mode to maintain a difference between EVI_{out} temp and EVI_{in} temp (EVI_{out} temp - EVI_{in} temp = 18°F). Optimal system superheat in heating mode is 18°F.

Safety Start

A combination of a pump down or pump out, soft start, and a mild start. Time associated with a safety start is directly related to securing 27°F DSH. Could last as long as 12 minutes. Compressor speed and capacity increase is limited during a safety start.

Normal Start

No limitations at start up. Compressors will start one at a time with normal increase in frequency and speed.

Cold Start

Cold start is based on (higher of CTT or CDT) – ODT < 27°F temperature at start up. By limiting the maximum frequency and the speed at which the compressor increases, cold start will minimize oil foaming and ensure proper oil levels in the compressor. Cold start will last until DSH is > 27°F.

Normal Operation

Judged after the soft start has ended. If DSH is greater than 18°F at point of judgment, the system will enter into normal operation.

Cold Operation

Judged at the point where soft start ends. If DSH is less than 18°F at point of judgment, the system will enter into cold operation until DSH is > 27°F.

Outdoor Unit

Quick Start

If there is more than a 30% request for capacity at start up. Outdoor unit(s) will start multiple compressors to meet heating and cooling requirements faster. Only applies within the heating/cooling quick start envelope. Cold start will take precedence over a quick start.

Oil Recovery Cycle

Used to bring oil back to the compressors in both heating and cooling mode. A fixed operation that operates off of system variables to determine the frequency of the oil recovery cycle. It will calculate the time between oil recovery cycles to be between 40 minutes – 7 hours based on outdoor unit capacity request and the compressor frequency.

Pump Down

After stopping the system in cooling mode, the indoor unit will close its EEV to pump down the indoor unit coil to prevent liquid refrigerant flood back at start up.

Pump Out

After stopping the system in heating mode, the outdoor unit will close its main EEV and pump refrigerant out of the outdoor unit coil to prevent liquid refrigerant flood back at start up.

Component Locations and Descriptions: Air-Cooled Units

Note: The number in parenthesis that follows each component name refers to the number (white on red) in the illustration that follows.

- Inverter Compressor (1)** Single or dual inverter-driven scroll compressors depending on unit size and voltage. Operating frequency range is between 20–140 Hz. The frequency of the compressor will change based on indoor unit capacity requests. A capacity request from an indoor unit is required to bring on a compressor. Once running, it will turn down to 14 Hz in special situations. Compressor(s) will run continuously until all indoor unit capacity requests are satisfied. Vapor injection can boost heating capacity by 20%.
- Cyclone Oil Separator (2)** Used to separate oil from the refrigerant at the discharge of the compressor. On a two-compressor model, oil is returned to the common suction line.
- Intercooler (3)** Secures up to 36°F of sub-cooling for liquid refrigerant used for cooling mode. Secures up to 3.6°F superheat for use during vapor injection to the compressor in heating mode.
- Accumulator (4)** Protects the compressor from liquid refrigerant flooding by separating liquid refrigerant from gas refrigerant. The accumulator collects excessive refrigerant. As the refrigerant boils off, it allows refrigerant in the form of vapor to enter the compressor.

Figure 48. Component locations: Major components

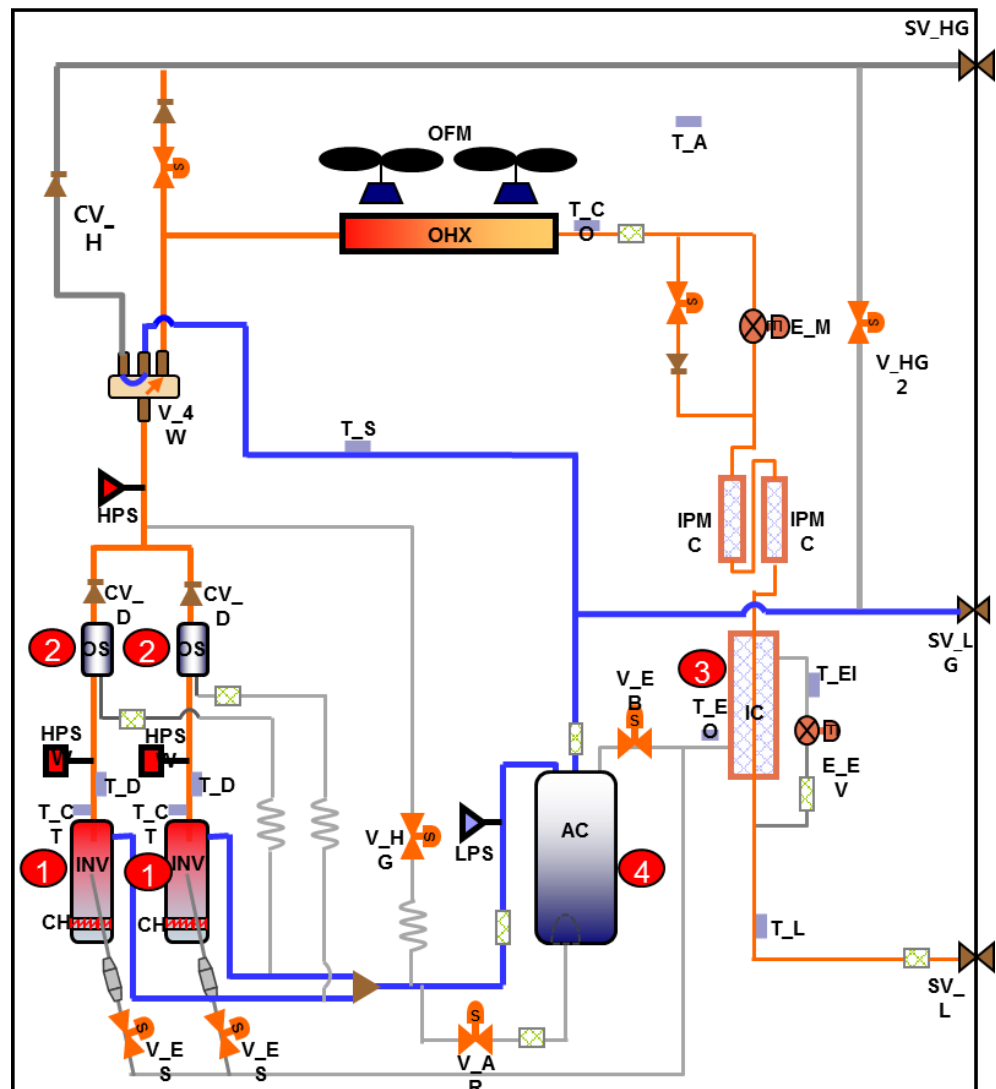

Outdoor Unit

Note: The number in parenthesis that follows each component name refers to the number (white on red) in the illustration that follows.

- Discharge temperature sensor (1)** 204CT type sensor. Measures the discharge line temperature.
- Compressor top temperature sensor (2)** 204CT type sensor. Measures the compressor top temperature.
- High pressure switch (3)** Safety switch opens on high pressure (650 psi). Power to the hub board is supplied through the high pressure switch. When the switch is open, power to the hub board is lost.
- High pressure sensor (4)** Measures high pressure.
- Ambient air temperature sensor (5)** 103AT type measures the outdoor ambient temperature.
- Condenser out temperature sensor (6)** 103AT type measures the refrigerant temperature when it leaves the outdoor unit coil.
- Liquid tube temperature sensor (7)** 103AT type, measures the liquid line temperature.
- EVlin and EVlout temperature sensor (8)** Two 103AT type measures the difference across the intercooler
- Suction tube temperature sensor 1 & 2 (9)** 1003AT type measures the suction tube temp of each compressor
- Suction pressure sensor (10)** Measures suction line pressure.

Figure 51. Component locations: Sensors

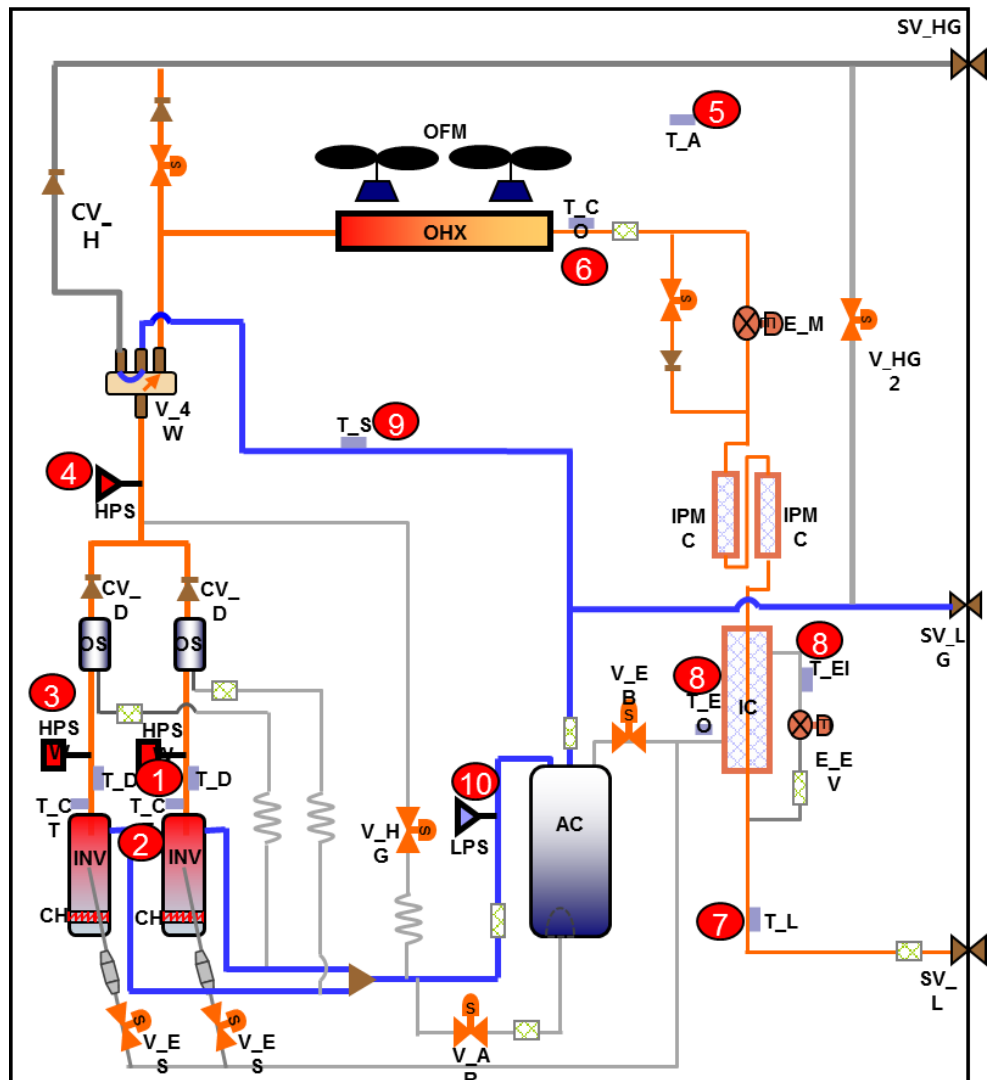

Component Locations and Descriptions: Water-Cooled Units

Figure 52. Major components for water-cooled units

Note: The numbers in red in the table to the right correspond to the numbers (white on red) in the illustration below.

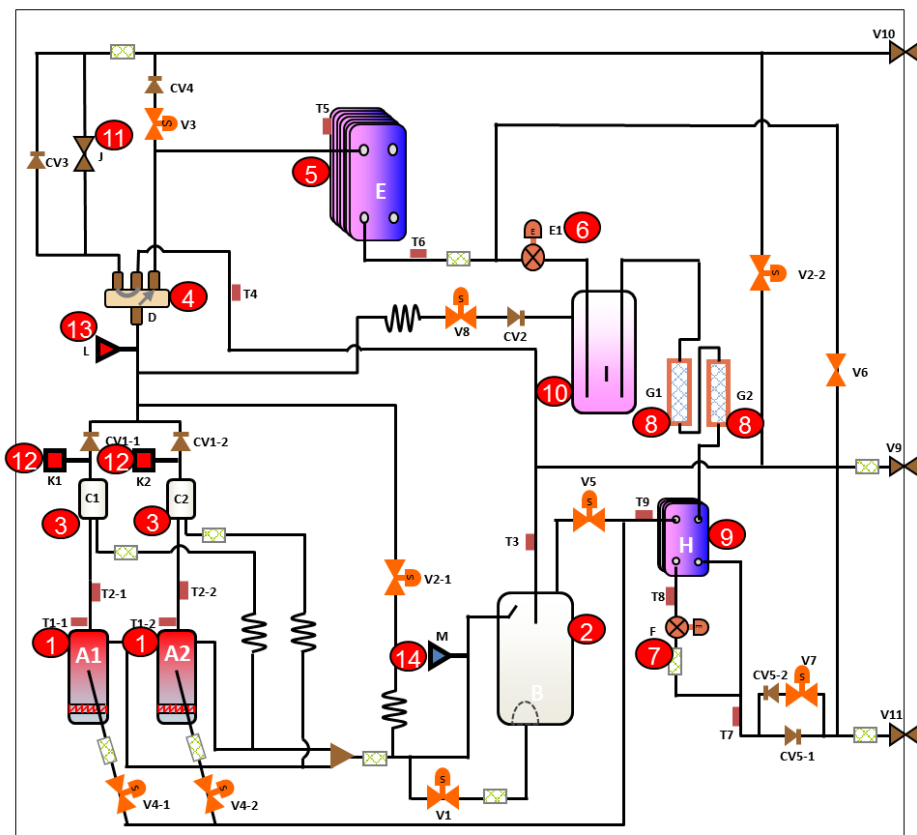

		Name
1	A1, A2	INV COMP
2	B	ACCUM
3	C1, C2	O/S
4	D	4WAY V/V
5	E	PLATE HEAT EXCHANGER
6	E1	MAIN EEV
7	F	EVI EEV
8	G1, G2	IPM COOLER
9	H	SUB COOLER
10	I	RECEIVER
11	J	HEAT PUMP V/V
12	K1, K2	HIGH PRE. S/W
13	L	HIGH PRE. SENSOR
14	M	LOW PRE. SENSOR
15	V1	ACCUM RETRUN V/V
16	V2-1, V2-2	HOT GAS BYPASS V/V
17	V3	MAIN COOLING V/V
18	V4-1, V4-2	EVI V/V
19	V5	EVI B/P V/V
20	V6	DPR V/V
21	V7	LIQUID TUBE V/V
22	V8	HOT GAS CHARGING V/V
23	V9	LOW PRE. GAS SERVICE V/V
24	V10	HIGH PRE. GAS SERVICE V/V
25	V11	LIQUID SERVICE V/V
26	CV1-1, CV-2	DISC. CHECK V/V
27	CV2	HRV CHECK V/V
28	CV3	HR CHECK V/V
29	CV4	MAIN COOL CHECK V/V
30	CV5-1, CV5-2	LIQUID TUBE CHECK V/V
31	T1-1, T1-2	COMP TOP SENSOR
32	T2-1, T2-2	DISC. SENSOR
33	T3	SUC. SENSOR 2
34	T4	SUC. SENSOR 1
35	T5	WATER SENSOR
36	T6	COND OUT SENSOR
37	T7	LIQUID TUBE SENSOR
38	T8	SC IN SENSOR
39	T9	SC OUT SENSOR

Outdoor Unit

Figure 53. Solenoid valves in water-cooled units

Note: The numbers in red in the table to the right correspond to the numbers (white on red) in the illustration below.

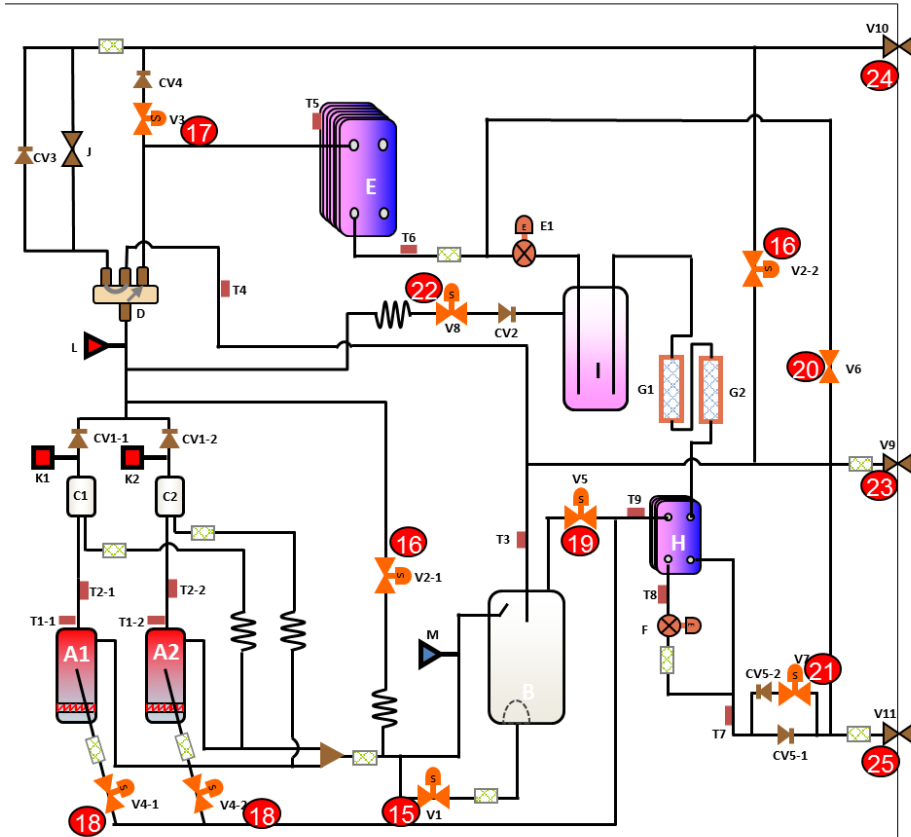

		Name
1	A1, A2	INV COMP
2	B	ACCUM
3	C1, C2	O/S
4	D	4WAY V/V
5	E	PLATE HEAT EXCHANGER
6	E1	MAIN EEV
7	F	EVI EEV
8	G1, G2	IPM COOLER
9	H	SUB COOLER
10	I	RECEIVER
11	J	HEAT PUMP V/V
12	K1, K2	HIGH PRE. S/W
13	L	HIGH PRE. SENSOR
14	M	LOW PRE. SENSOR
15	V1	ACCUM RETRUN V/V
16	V2-1, V2-2	HOT GAS BYPASS V/V
17	V3	MAIN COOLING V/V
18	V4-1, V4-2	EVI V/V
19	V5	EVI B/P V/V
20	V6	DPR V/V
21	V7	LIQUID TUBE V/V
22	V8	HOT GAS CHARGING V/V
23	V9	LOW PRE. GAS SERVICE V/V
24	V10	HIGH PRE. GAS SERVICE V/V
25	V11	LIQUID SERVICE V/V
26	CV1-1, CV-2	DISC. CHECK V/V
27	CV2	HRV CHECK V/V
28	CV3	HR CHECK V/V
29	CV4	MAIN COOL CHECK V/V
30	CV5-1, CV5-2	LIQUID TUBE CHECK V/V
31	T1-1, T1-2	COMP TOP SENSOR
32	T2-1, T2-2	DISC. SENSOR
33	T3	SUC. SENSOR 2
34	T4	SUC. SENSOR 1
35	T5	WATER SENSOR
36	T6	COND OUT SENSOR
37	T7	LIQUID TUBE SENSOR
38	T8	SC IN SENSOR
39	T9	SC OUT SENSOR

Figure 54. Check valves in water-cooled units

Note: The numbers in red in the table to the right correspond to the numbers (white on red) in the illustration below.

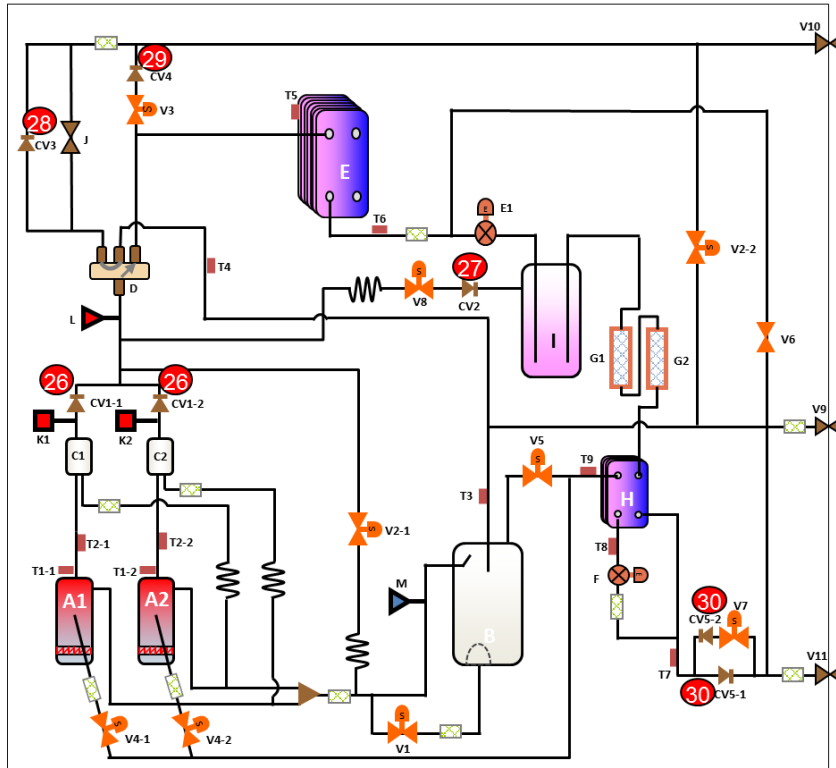

		Name
1	A1, A2	INV COMP
2	B	ACCUM
3	C1, C2	O/S
4	D	4WAY V/V
5	E	PLATE HEAT EXCHANGER
6	E1	MAIN EEV
7	F	EVI EEV
8	G1, G2	IPM COOLER
9	H	SUB COOLER
10	I	RECEIVER
11	J	HEAT PUMP V/V
12	K1, K2	HIGH PRE. S/W
13	L	HIGH PRE. SENSOR
14	M	LOW PRE. SENSOR
15	V1	ACCUM RETRUN V/V
16	V2-1, V2-2	HOT GAS BYPASS V/V
17	V3	MAIN COOLING V/V
18	V4-1, V4-2	EVI V/V
19	V5	EVI B/P V/V
20	V6	DPR V/V
21	V7	LIQUID TUBE V/V
22	V8	HOT GAS CHARGING V/V
23	V9	LOW PRE. GAS SERVICE V/V
24	V10	HIGH PRE. GAS SERVICE V/V
25	V11	LIQUID SERVICE V/V
26	CV1-1, CV-2	DISC. CHECK V/V
27	CV2	HRV CHECK V/V
28	CV3	HR CHECK V/V
29	CV4	MAIN COOL CHECK V/V
30	CV5-1, CV5-2	LIQUID TUBE CHECK V/V
31	T1-1, T1-2	COMP TOP SENSOR
32	T2-1, T2-2	DISC. SENSOR
33	T3	SUC. SENSOR 2
34	T4	SUC. SENSOR 1
35	T5	WATER SENSOR
36	T6	COND OUT SENSOR
37	T7	LIQUID TUBE SENSOR
38	T8	SC IN SENSOR
39	T9	SC OUT SENSOR

Outdoor Unit

Figure 55. Sensors

Note: The numbers in red in the table to the right correspond to the numbers (white on red) in the illustration below.

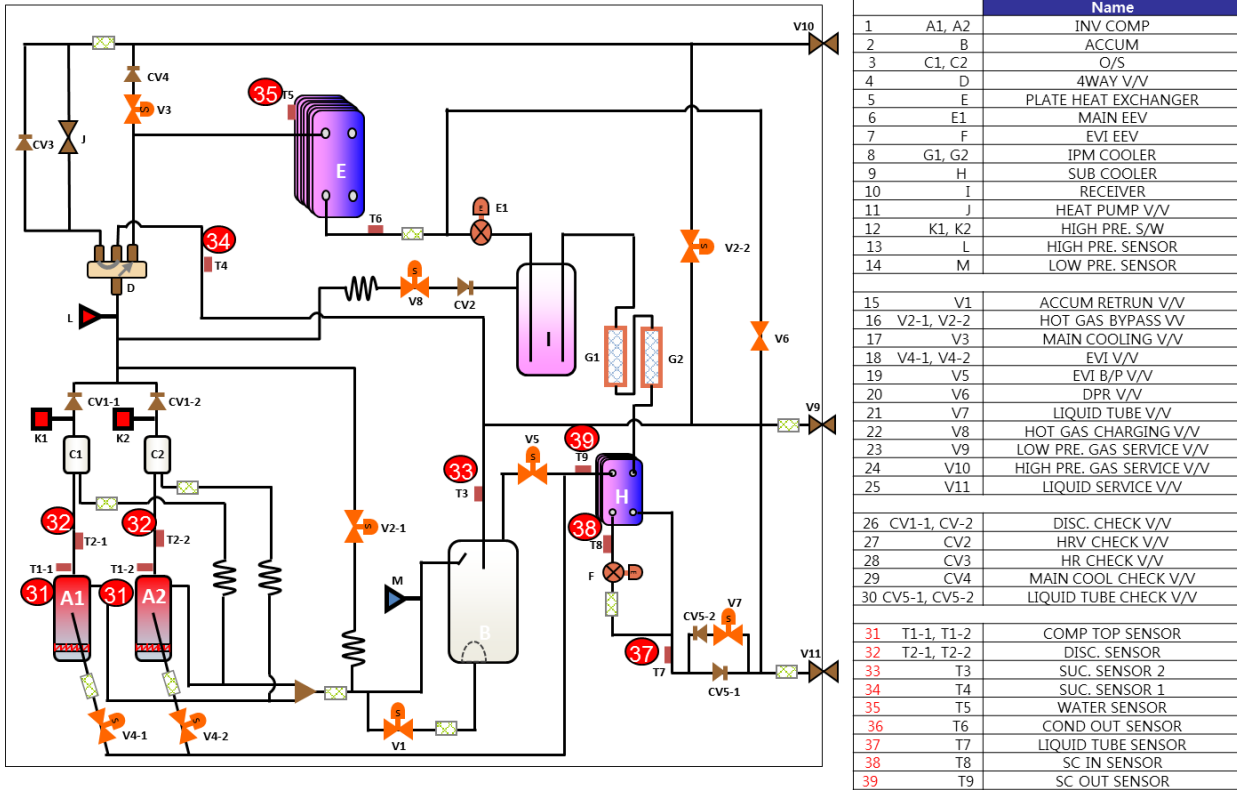

Flow Switch (Water-Cooled Unit)

Mandatory, field-provided flow switch to prove water flow prior to compressor starting.

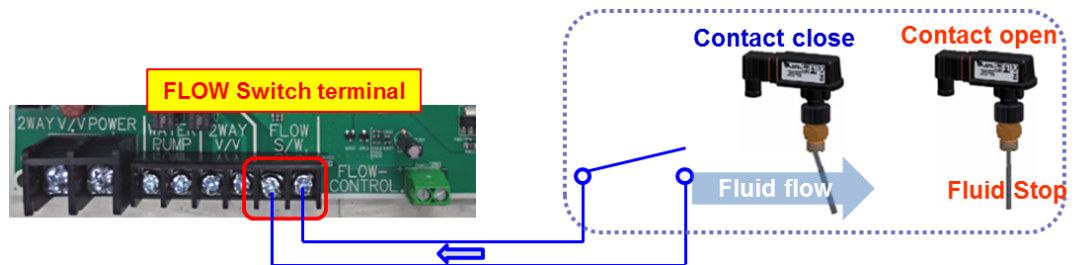

Water flow rate	Contact signal	Set working
Above setpoint	Close	System working normally
Below setpoint	Open	System stop and error (E435)

Strainer (Water-Cooled Unit)

Mandatory field-supplied strainer for removing particulate matter from the cooling water.

Flow Control Valve (Water-Cooled Unit)

Control Range

WCU option setting (option 15)

Note: Minimum: 3 V. (Supply can be unstable below 3 V.)

Digit 1, 2	Digit 3, 4	Control range
15	00	Not used
	01	7-10 V
	02	5-10 V
	03	3-10 V

Control Start

Valve begins control 10 minutes after compressor is on.

Flow Rate Decrease

- Current condition = voltage down condition for 20 minutes
- Output = current value – 1 V
- Flow rate increase (full open)
- Any protection control output = 10 V (immediately)

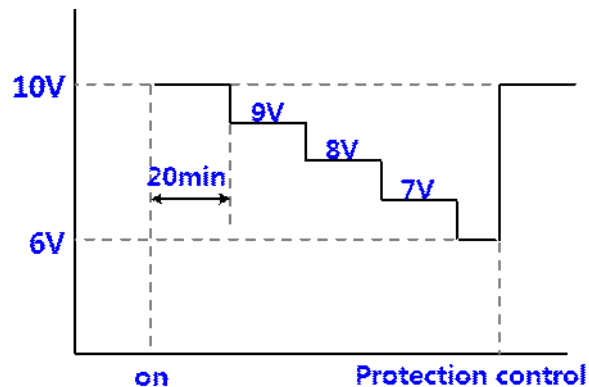

Voltage down conditions				
Water temperature	< 50°F	< 68°F	< 95°F	< 122°F
For cooling	<(max. comp Hz)*0.8°F	<(max. comp Hz)*0.6°F	<(max. comp Hz)*0.4°F	<(max. comp Hz)*0.2°F
For heating	<(max. comp Hz)*0.2°F	<(max. comp Hz)*0.4°F	<(max. comp Hz)*0.6°F	<(max. comp Hz)*0.8°F
Time	Stabilize for 20 minutes			

- **Signal output terminal:** 0-10 V
- **Power supply:** 220 V (max 0.2 A, 250 V)
- **Outdoor unit option setting required**
- **Two scenarios for wiring valve** (Figure 56 and Figure 57)

Figure 56. Wiring flow control valve where amp draw exceeds 0.2 A

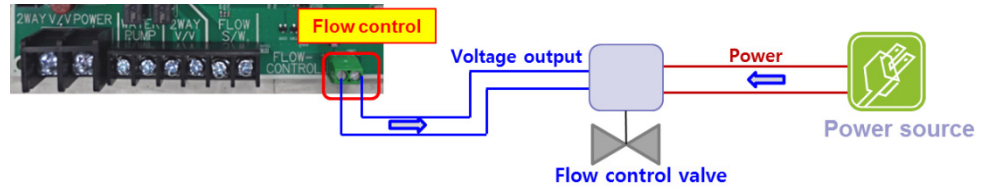
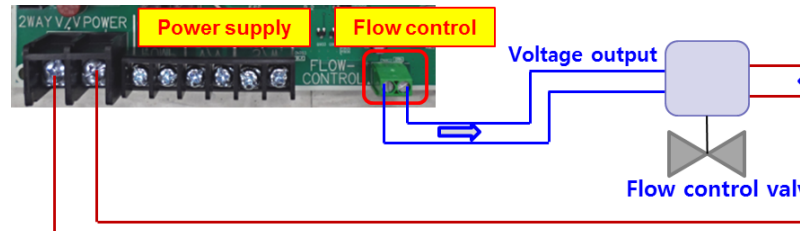
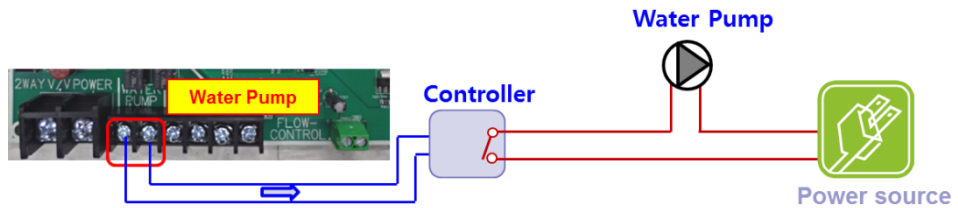

Figure 57. Wiring flow control valve where amp draw does not exceed 0.2 A



Water Pump (Water-Cooled Unit)

Supplies water to the unit for heating and cooling operation.



Remote controller	Contact signal	Water pump	Notes
On	Close (30 seconds after controller On)	On	Delay for water pump On
Off	Open (30 seconds after controller Off)	Off	Delay for PHE

Modes of Operation

Heat Pump

Heat pump outdoor units have two modes of operation: Heating and Cooling. Mixed mode operation is not allowed.

Heat Recovery

Heat recovery outdoor units have four modes of operation: Cooling, Mainly Cooling, Heating, and Mainly Heating. A heat recovery system must be used in conjunction with a mode control unit (MCU) to accomplish mixed modes of operation.

Figure 58. Heat Recovery: Cooling

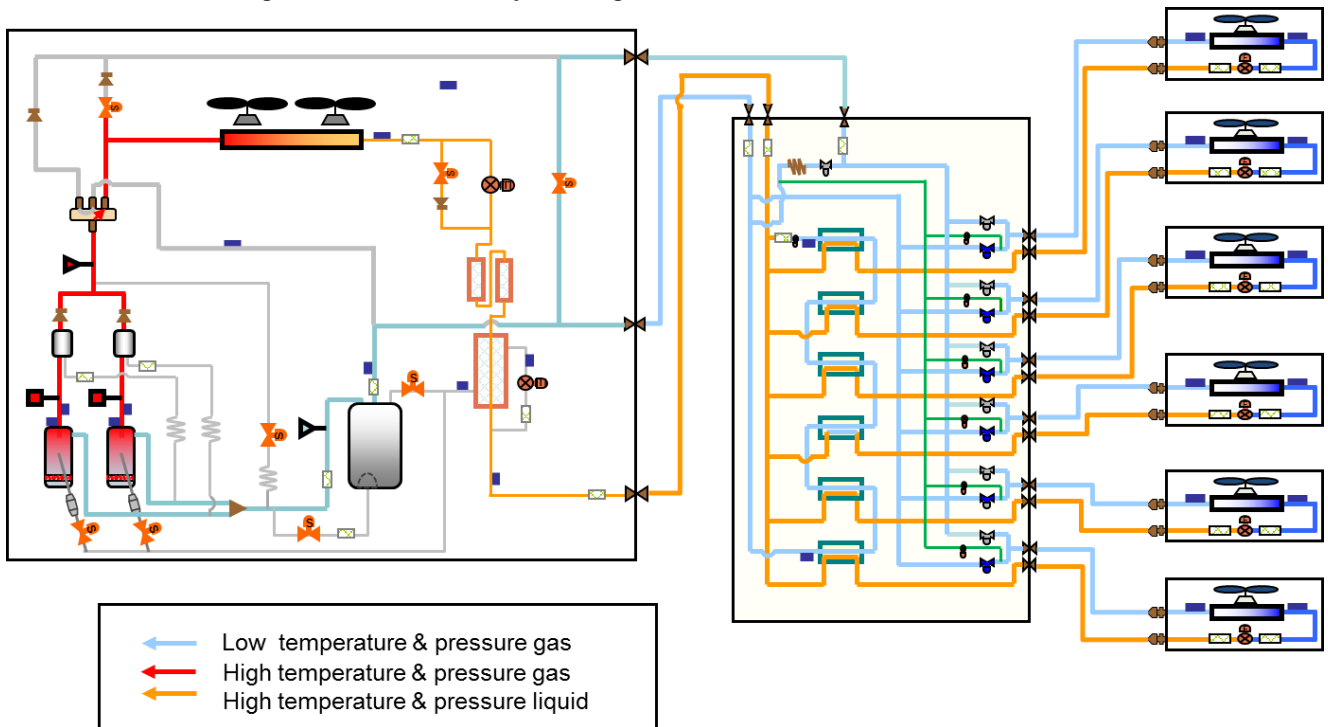

Figure 59. Heat Recovery: Mainly Cooling

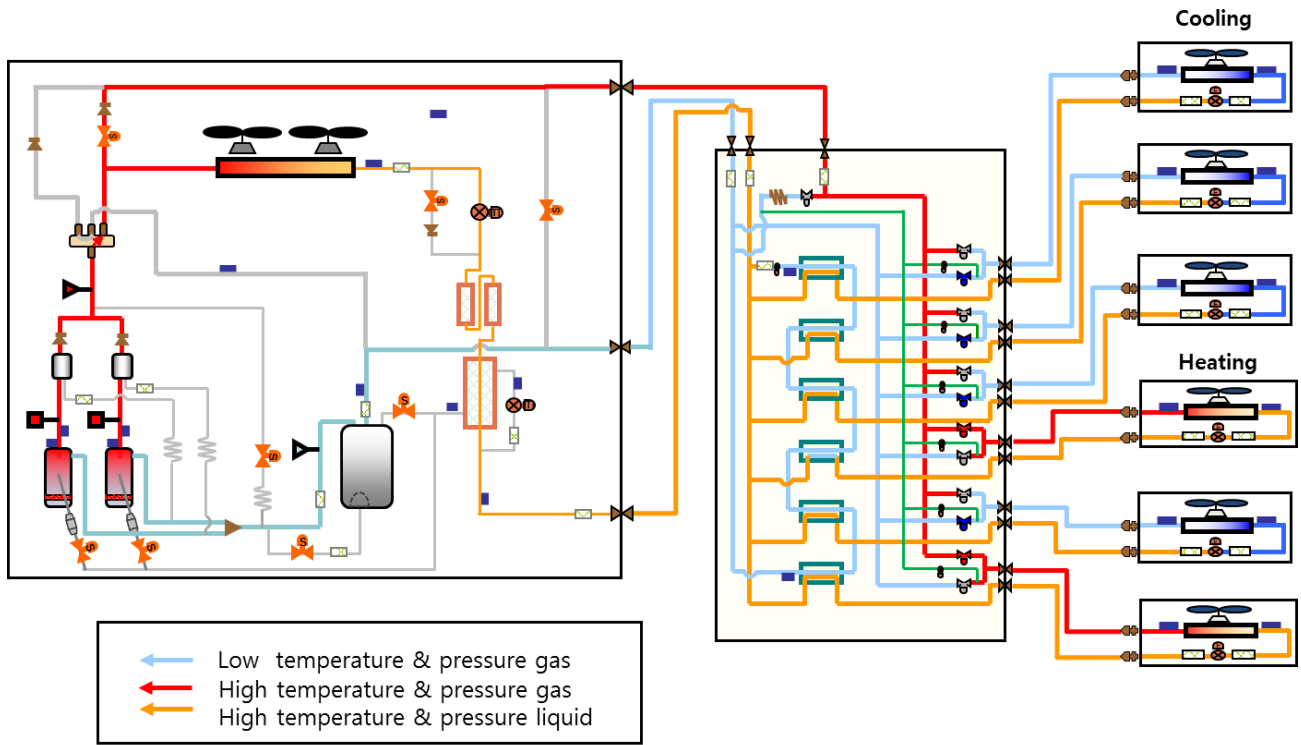

Figure 60. Heat Recovery: Heating

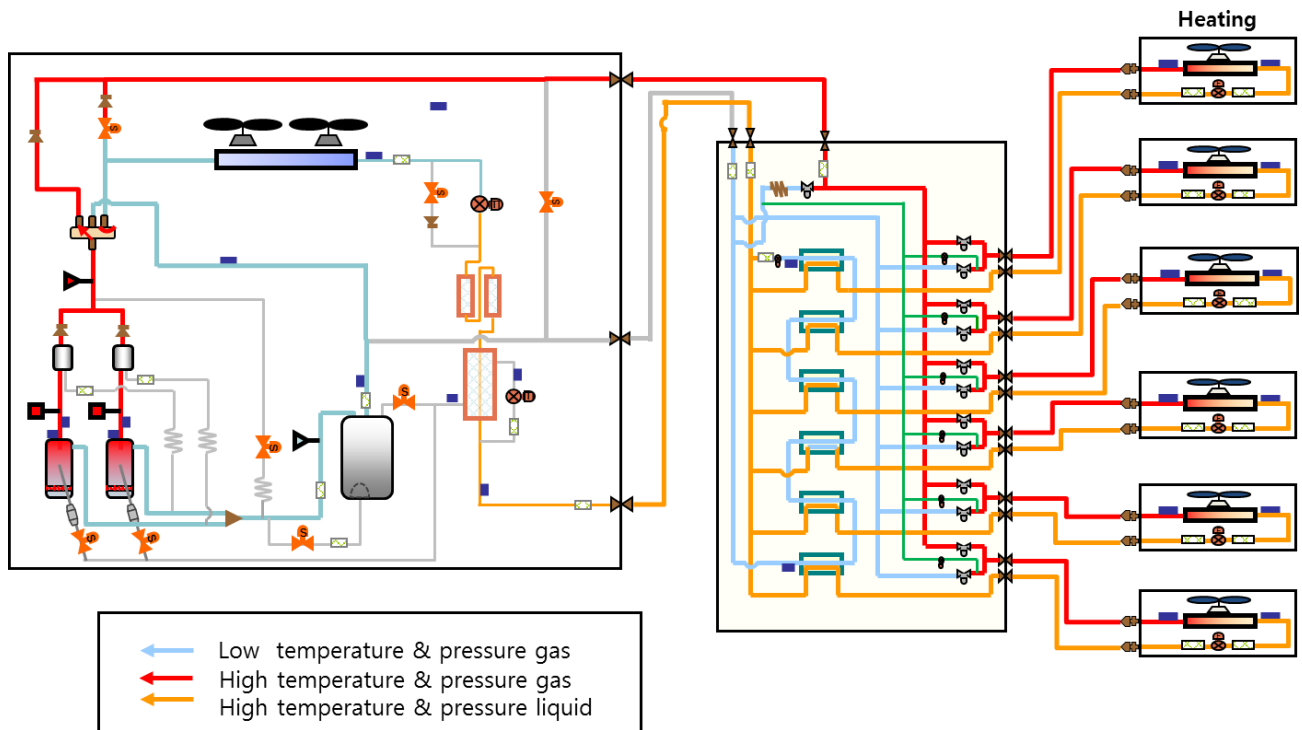
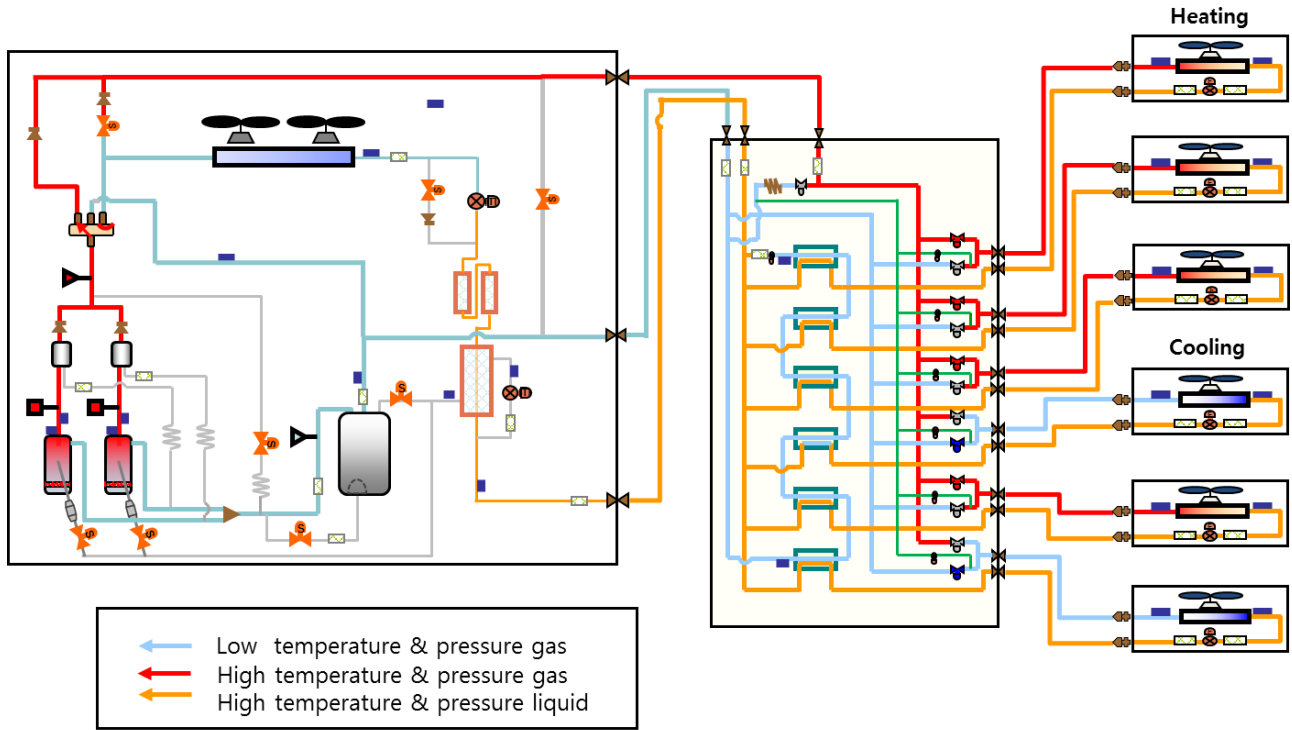

Figure 61. Heat Recovery: Mainly Heating



Water-Cooled Units: Heat Pump Installations

Water-cooled units can be installed as either heat pump or heat recovery units. For heat pump installations, only two pipes are used.

Figure 62. Water-Cooled Unit—Heat Pump: Cooling

Note: On a water-cooled heat pump installation, only two pipes are used.

- ▷ Low Pressure Gas Indoor Y-joint
- ▷ High Pressure Liquid Indoor Y-joint

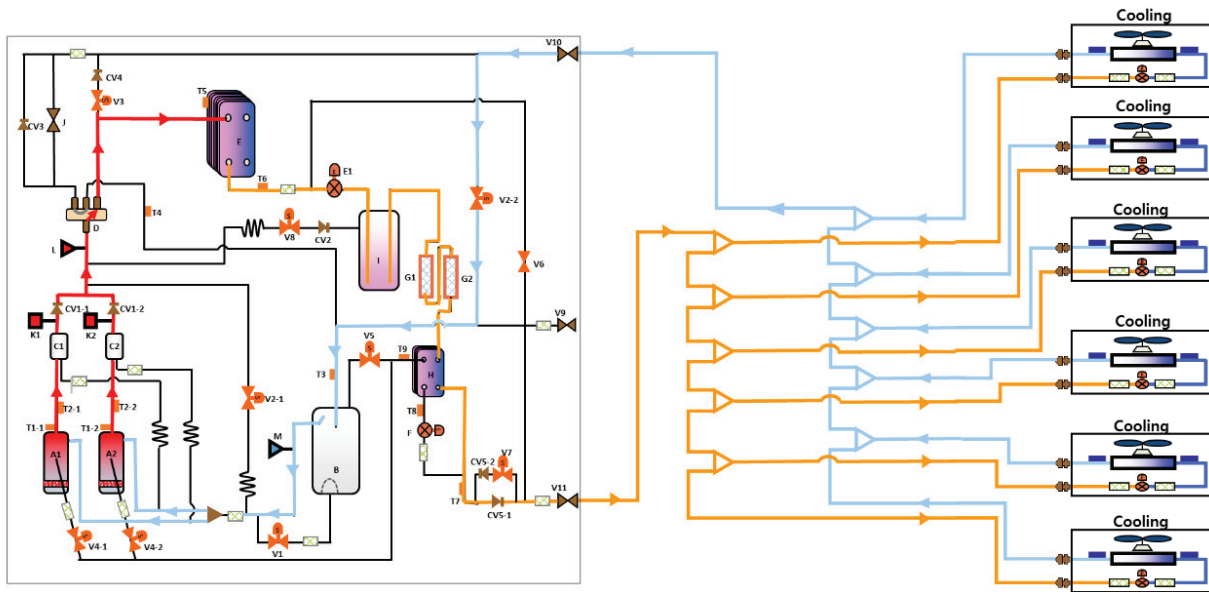

Figure 63. Water-Cooled Units—Heat Pump: Heating

Note: On a water-cooled heat pump installation, only two pipes are used.

- ▷ High Pressure Gas Indoor Y-joint
- ▷ High Pressure Liquid Indoor Y-joint

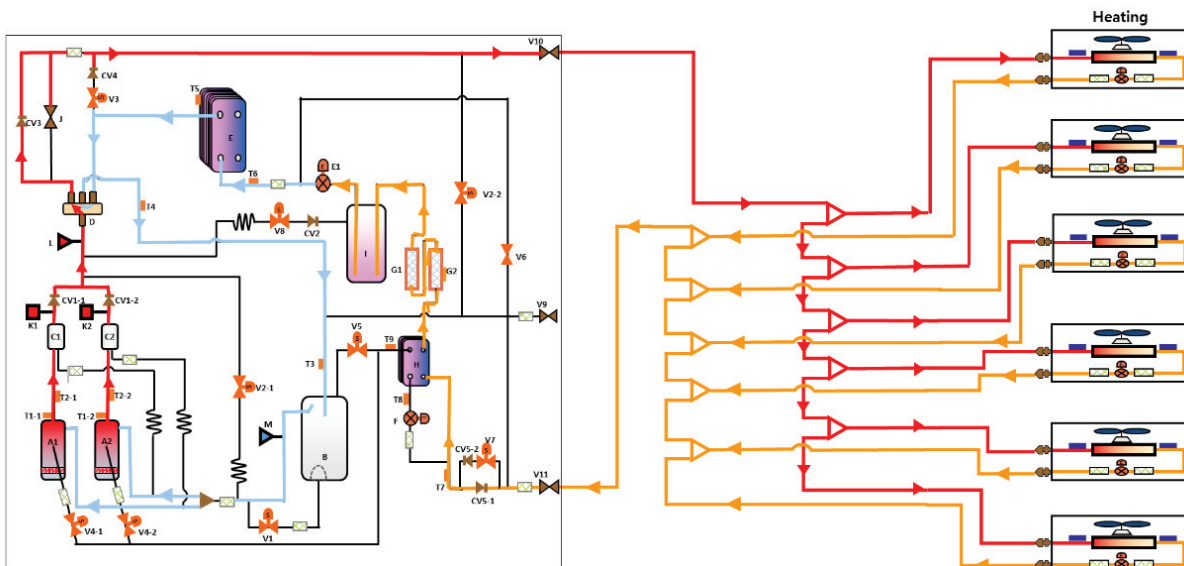

Figure 64. Water-Cooled Units—Heat Recovery: Cooling

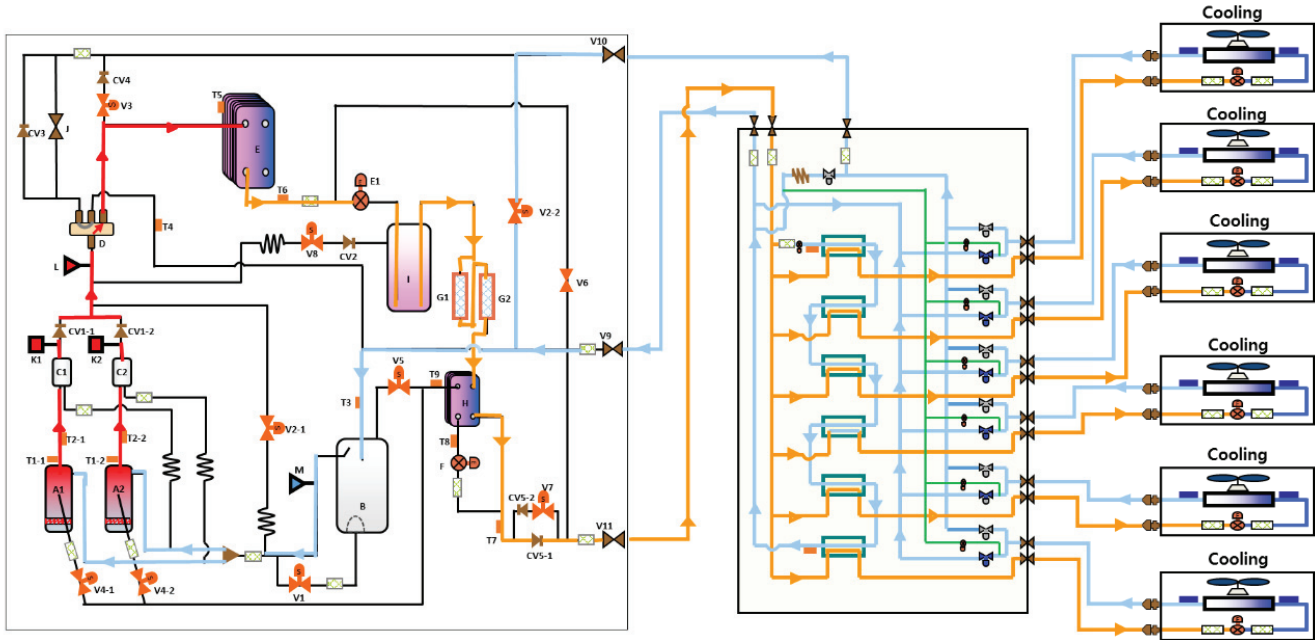

Figure 65. Water-Cooled Units—Heat Recovery: Mainly Cooling

Heat Recovery Mainly Cooling

- ← Low temperature & pressure gas
- ← High temperature & pressure gas
- ← Mid temperature & High pressure liquid
- ← Equalizing line

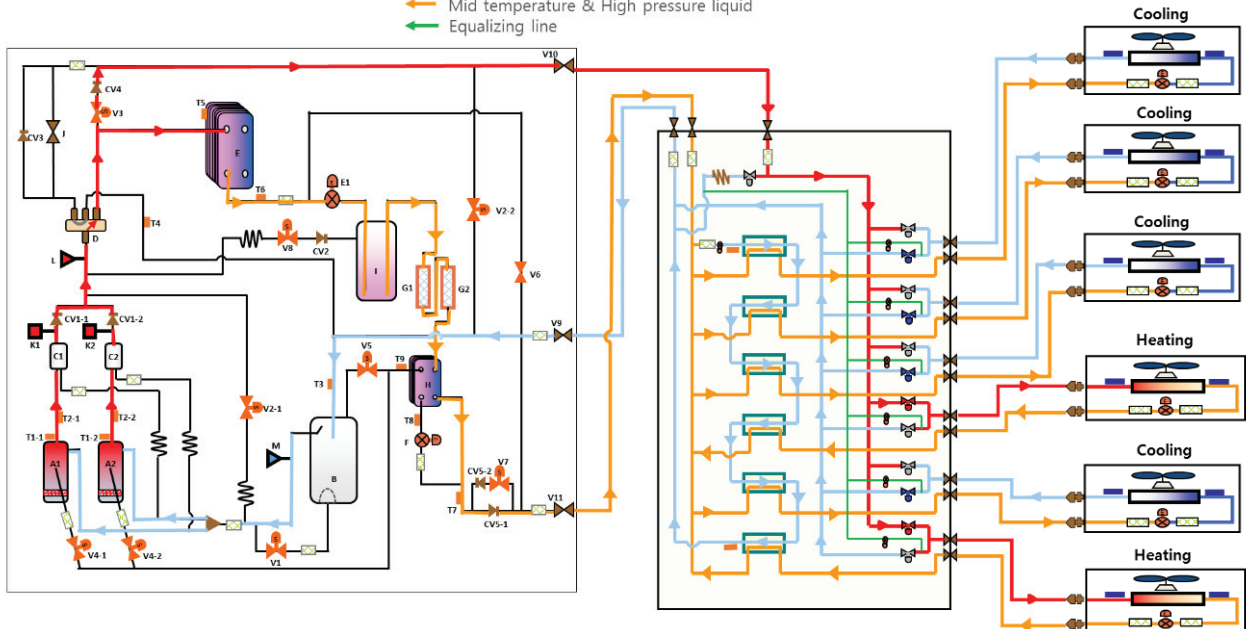

Figure 66. Water-Cooled Units—Heat Recovery: Heating

Heat Recovery Heating Only

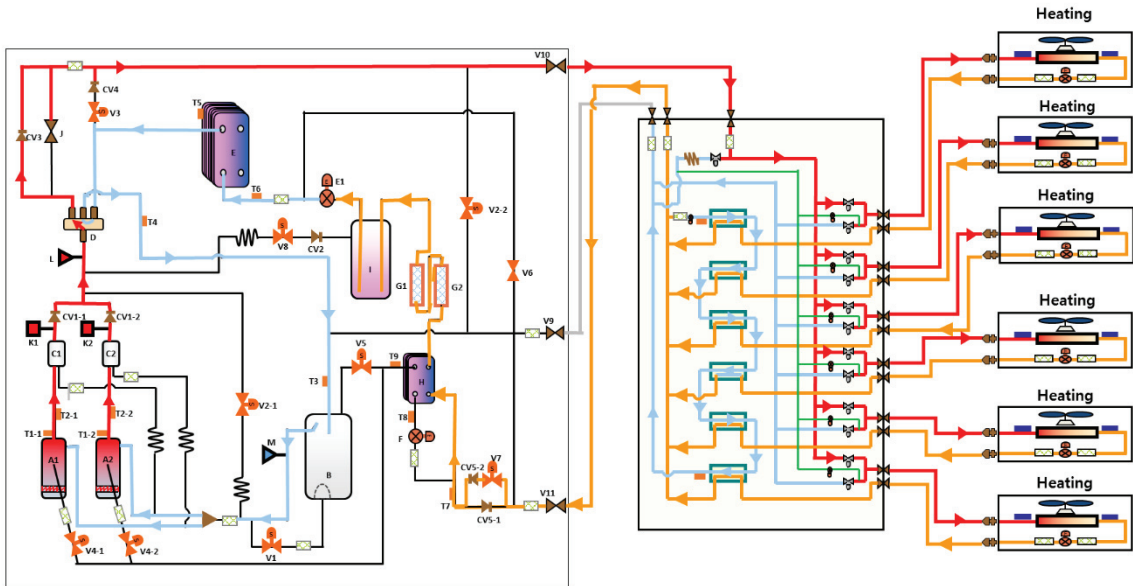
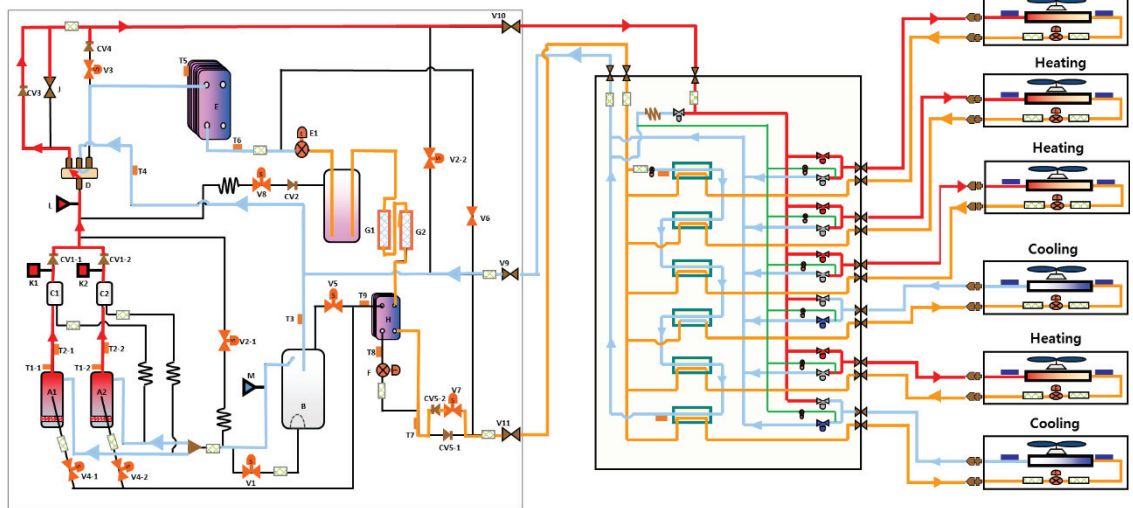

Figure 67. Water-Cooled Units—Heat Recovery: Mainly Heating

Heat Recovery Mainly Heating

- ← Low temperature & pressure gas
- ← High temperature & pressure gas
- ← Mid temperature & High pressure liquid
- ← Equalizing line



Outdoor Unit and Compressor Operating Priority

The main outdoor unit changes priority based on operating conditions. This is different from the main designated by DIP switches. The main designated by DIP switches will always remain the main outdoor unit from which all error codes are read and communications between the systems are transmitted and received.

The main outdoor unit based on operating priority is the main for no more than 60 minutes after which a new main outdoor unit is chosen. A new main will also be chosen if a defrost cycle, oil recovery cycle, or all outdoor units are off because they have satisfied setpoint and the main has operated for more than 60 minutes.

Another method by which a new main by operating priority is chosen is when an outdoor unit is off for more than 40 minutes, it will be started to become the new main. The old main will be shut down if not needed.

Compressor Starting and Rotation

Compressor #1 of the designated main outdoor unit will always be the first to run at initial start-up or when power is restored after a loss. After the outdoor unit operating priority changes (see "Outdoor Unit and Compressor Operating Priority"), the compressor with the least amount of runtime in the main outdoor unit designated by operating priority will be the first to start upon a call for capacity.

After initial start-up, the designated compressor, determined the operating priority, will start upon any request for capacity by an indoor unit. The remaining compressors will be brought online until all compressors in the system are running. If capacity is such that all compressors running is not necessary, compressors will be shut down until compressor capacity matches indoor unit capacity request.

When more capacity is needed from compressors, any subsequent compressors are brought online when the first compressor reaches 60 Hz for 3 minutes or the first compressor reaches 76 Hz. At 76 Hz, the second compressor will start without delay. Compressor #2 will always run at compressor #1 frequency ± 5 Hz. After capacity requirements have been determined, any unnecessary compressors will be shut down.

Compressors are designed to run between 30–80 Hz for maximum efficiency.

Figure 68. Control logics: Dual compressors starting

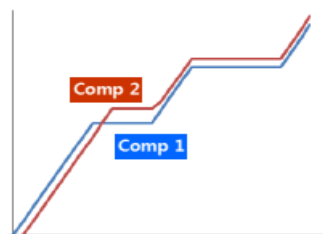

Figure 69. Additional compressor starting



Special Functions

Special functions are available to maximize operation of the VRF system. Their use is determined by application or by need. For details about the special functions that require configuration, see the outdoor unit IOM (VRF-SVN34*).

Emergency Compressor Operation

Auto Backup

In the event of a compressor error code for a two-compressor system, the second compressor will run for 12 hours if the occupant turns it on at the controller and sets mode and setpoint in order for the system to run. The error code will appear every 12 hours and the system will shut down every 12 hours. The system will have to be restarted every 12 hours through the controller. The remaining compressors will run minus the failed compressor for 12 hours. This will not have to be accessed through the K-buttons. It is a default operation.

Compressor Lockout

An outdoor unit selectable function that locks out a compressor that has produced an error code. The remaining compressors will run minus the compressor that is locked out. If this function is enabled, this function disables the auto backup function along with subsequent error codes for the compressor that is locked out.

Note: If either of these conditions (auto backup and compressor lockout) exist, the indoor unit capacity request will have to be reduced manually (unit is off at controller) to match remaining compressor capacity in order to prevent loss of oil back to the operating compressor.

Cooling Capacity Correction

Changes targeted EVA_{in} temperature in order to affect indoor unit discharge air temperature. Default target EVA_{in} temperature is 44.6 – 48.2°F.

Cooling capacity correction	Main	0	1	0	0	44.6-48.2 (7-9): factory default	Targeted evaporating temperature: °F(°C). When low temperature value is set, indoor unit discharged air temperature will decrease.
				0	1	41-44.6 (5-7)	
				0	2	48.2-51.8 (9-11)	
				0	3	50-53.6 (10-12)	
				0	4	51.8-55.6 (11-13)	
				0	5	53.6-57.2 (12-14)	
				0	6	55.4-59 (13-15)	

Heating Capacity Correction

Changes targeted head pressure to affect indoor unit discharge air temperature. Default target pressure is 435.1 psig.

Heating capacity correction	Main	0	2	0	0	435.1 (3.0): factory default	Targeted high pressure: psi (MPa). When low pressure value is set, discharged air temperature of the indoor unit will decrease.
				0	1	362.6 (2.5)	
				0	2	377.1 (2.6)	
				0	3	391.6 (2.7)	
				0	4	406.1 (2.8)	
				0	5	420.6 (2.9)	
				0	6	449.6 (3.1)	
				0	7	464.1 (3.2)	
				0	8	478.6 (3.3)	

Current Restriction Rate

When current restriction rate is set, this function allows for energy management to use real-time control of the maximum operating current during either low power supply conditions or when excessive use of power needs to be restricted.

Figure 70. Current restriction rate

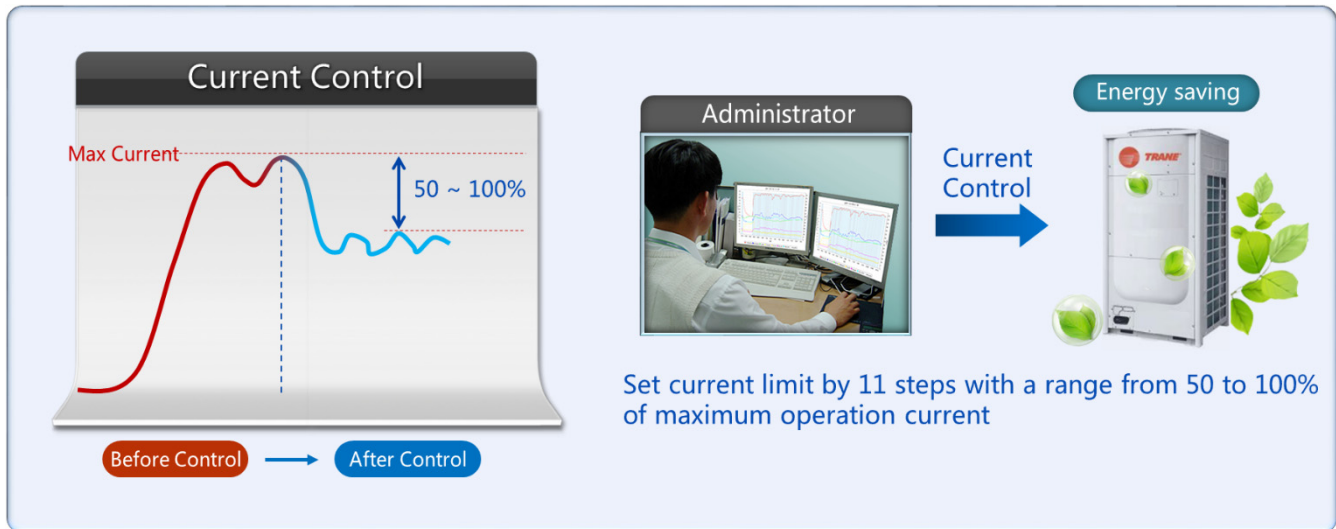

Outdoor Unit Fan Speed Correction

When outdoor unit fan speed correction is set, this function will increase or decrease maximum outdoor unit fan step to help maintain target head pressure in cooling mode and target low pressure in heating mode. One step is approximately 20 rpm.

Tonnage	6	8	10	12	Remarks
Maximum Fan Steps Cooling and Heating	19	29	29	31	Default option set
Cooling ODT 89.6°F	23	35	35	35	Example
Heating ODT 50°F	17	25	25	25	Example

Nighttime Silent Mode

After six hours of peak outdoor temperature operation, the unit will reduce decibel output based on outdoor unit setting for a maximum of 12 hours. There are three nighttime silent mode level settings at the outdoor unit.

Level	Outdoor fan	Compressor Hz
1	Ave. max. step 10 % ↓	-
2	Ave. max. step 36 % ↓	Ave. max. Hz 17% ↓
3	Ave. max. step 55 % ↓	Ave. max. Hz 30% ↓

Outdoor Unit

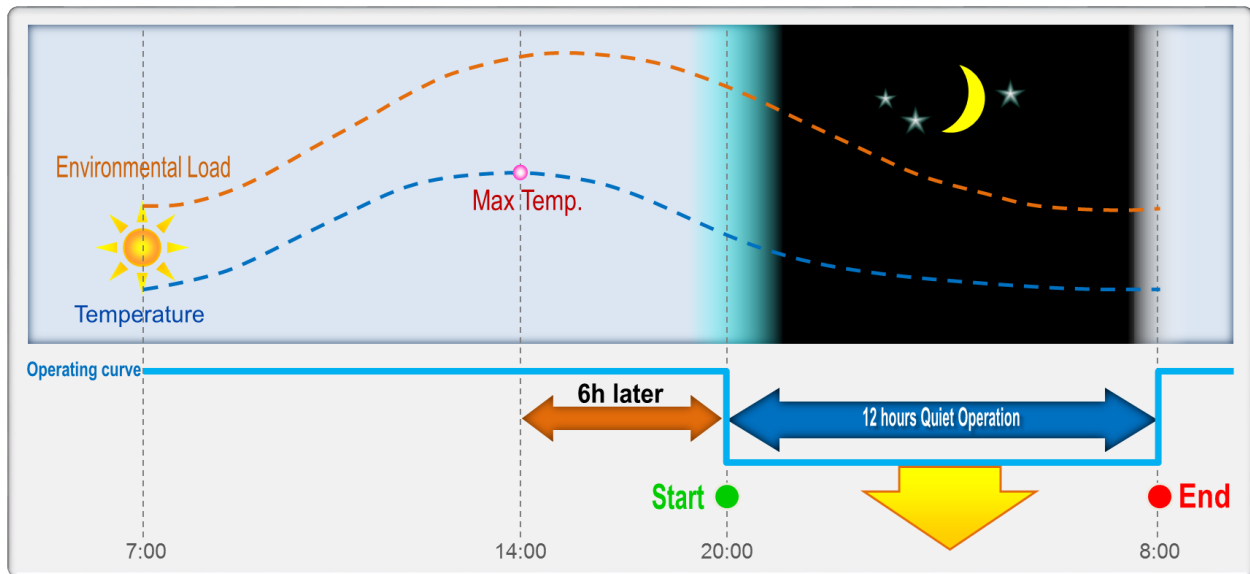

High Head Condition Setting

When high head condition is set, it compensates for high head pressure due to a large height differential caused by outdoor unit located above or below indoor unit. This function may need to be enabled when height differential exceeds 131 feet. There are three cases for which this function applies:

- Case 1—Outdoor unit is above indoor unit by 131–261 ft.
- Case 2—Outdoor unit is above indoor unit by more than 262 ft.
- Case 3—Outdoor unit is below the indoor unit by more than 98 ft.

Long Piping Situation

When a long piping situation exists, this setting optimizes system operation based on installation pipe lengths, EEVs, and other controls. It compensates for the pressure drops associated with longer piping lengths. There are two settings available that are based on the distance of the farthest indoor unit from the outdoor unit.

- Disabled—Factory default
- Level 1—The farthest indoor unit is 328–557 ft from the outdoor unit.
- Level 2—The farthest indoor unit is > 557 ft from the outdoor unit.

Energy Saving Mode

Note: Available only for heating mode.

When enabled, if the average (set temperature – room temperature) < 3.6°F, the target high pressure is then reduced by 42 psig. In heating mode, target high pressure will not be reduced to below 369 psig.

Expanded Operation for Low Ambient Cooling

Note: Applies only to heat recovery units.

When selected, provides continuous cooling even when the outdoor temperature falls to 5°F. This function requires two ports on the MCU to serve 18–30 MBh.

MCU models	4MCUCUY6NC****	4MCUCUY4NC****	4MCUCUY2NC****
Normal operation	1 port 30 MBh	1 port 30 MBh	2 port 36 MBh
Low ambient operation to 5°F	2 port 18–30 MBh	2 port 18–30 MBh	
Note: Outdoor unit main control board should be set for expanded cooling operation.			

Snow Accumulation Prevention

Factory default is set to enable this function. When enabled, the outdoor unit is in satisfied or standby mode, and the outdoor temperature is below 34°F, the outdoor unit fan will run for 1 minute every 30 minutes to prevent snow accumulation on the outdoor unit fan. This function prevents premature failure of the fan or outdoor unit caused by snow accumulation on the outdoor unit fan.

VRF System

System Start Conditions

Air-Cooled Units

Trane VRF systems provide reliable startup of compressors down to 5°F in Cooling mode. Units can start below cataloged temperatures, but their startup reliability is reduced. Units will not shut down if running below cataloged temperatures.

Trane VRF systems provide reliable starting of compressors down to -14°F in Heating mode. Units will not shut down if running below cataloged temperatures. Units will stop heating operation when the outdoor ambient temperature exceeds 86°F.

Figure 71. Heating and cooling operating envelope

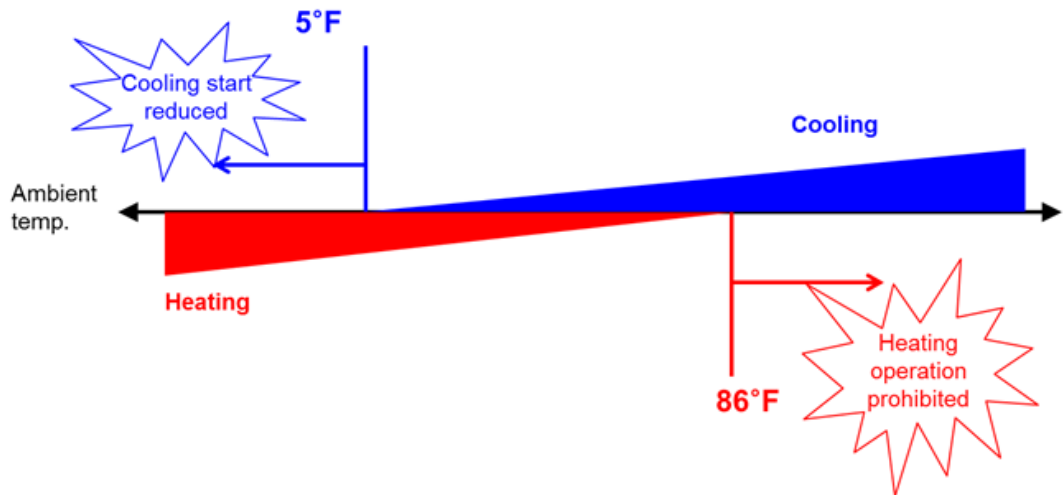

Water-Cooled Units

For the operating envelope for water-cooled units, refer to the Water-Source Unit Series IOM (VRF-SVN070*).

For water-cooled units, the sequence shown in the pre-start flow chart (Figure 72) occurs prior to the logic explained in the sections that follow.

Figure 72. Water-cooled unit pre-start flow chart

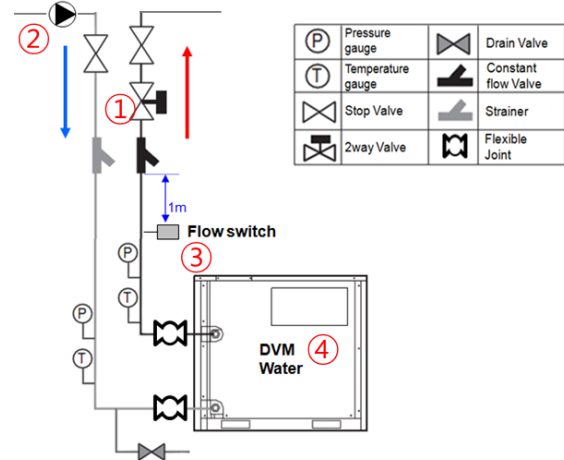
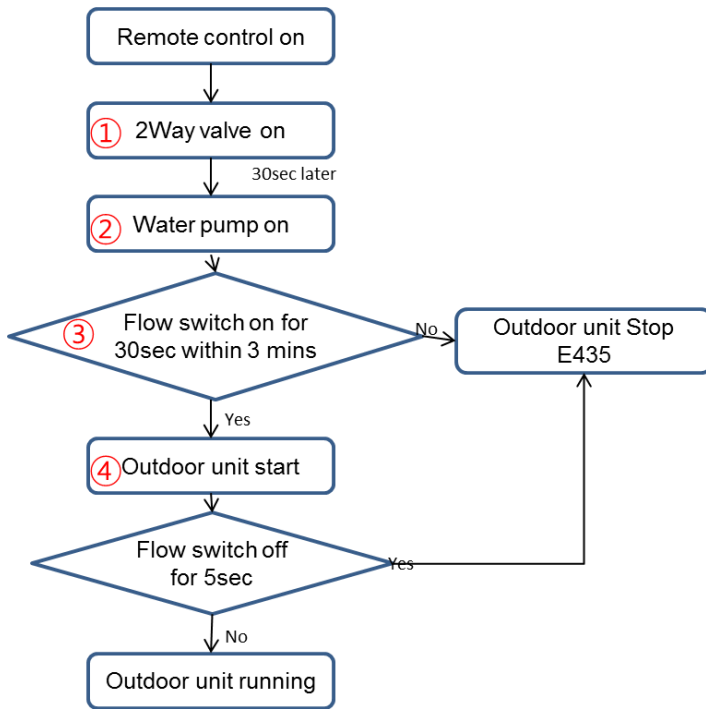

Cooling Mode

Note: The following sequence is based on a two-compressor system. For single-compressor systems, disregard references to a second compressor.

Compressor Starting Sequence

Upon a call for cooling from an indoor unit, a safety start is implemented for upwards of 12 minutes to ensure an optimal system start. During this time, and before the compressor starts, a logic judgment is made on how best to safely start the system based on the requested capacity and outdoor ambient temperature while preventing liquid floodback to the compressors.

After the judgment is complete, all enabled MCU EEVs open to 480 steps. When the cooling solenoid valve energizes on the MCU, any unit not requesting cooling capacity or in Heating mode will have its MCU EEV driven to 0 steps. The indoor unit EEV will open to 250 steps for the duration of safety start. EVI solenoid 1 and EVI solenoid 2 energize. The main EEV opens to 2000 steps. The EVI bypass solenoid energizes. The HGBP 1 energizes. The crankcase heaters energize if power has not been applied for more than 12 hours prior to start.

When the designated main compressor starts, but is still in a Safety Start mode, a logic judgment is made on how best to safely start the system while preventing liquid floodback to the compressors.

Figure 73. System start-up flow chart

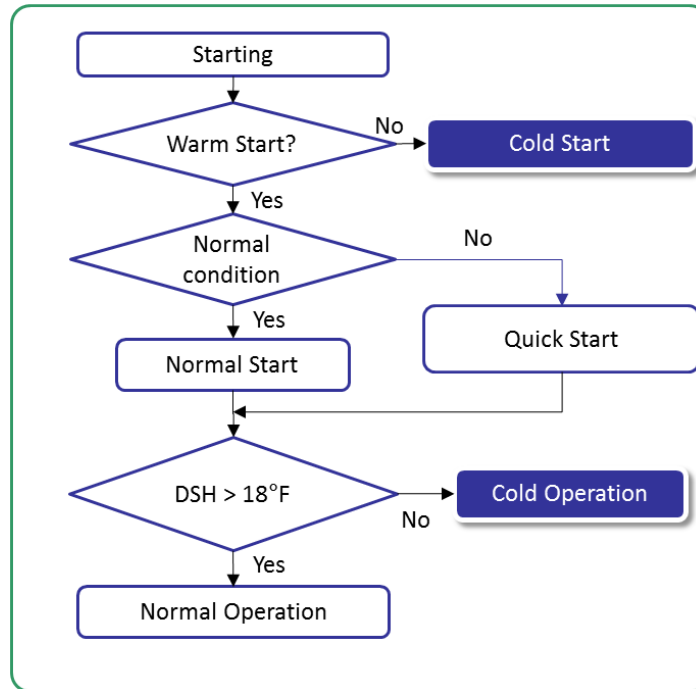

After the judgment is complete, the offline compressor EVI solenoid closes. While still in a Safety Start mode, the second compressor starts and the EVI solenoid associated with that compressor energizes. After 27°F discharge superheat (DSH) is achieved, the system will exit the Safety Start mode and the HGBP 1 valve de-energizes. If necessary, the HGBP 1 will energize during abnormally low suction pressure with normal operation in Cooling mode. If the suction pressure falls to 45 psig, the HGBP 1 will energize to increase suction pressure. If the suction pressure rises above 59 psig, the HGBP 1 will de-energize.

Normal Start

Outdoor Unit

After the release to a normal start, all compressors will start in both single unit or module systems. If capacity request does not meet the need for multiple compressors to be running, any unnecessary compressors and associated valves will shut down when their minimum run timers expire. If capacity request dictates that multiple compressors are required, the required compressors will continue to run.

When the system has settled out, HGBP 2 will open (HR system, Cooling mode only) to bring back low pressure suction gas on the low pressure suction line and the high pressure suction line together. Doing so effectively increases the volume of refrigerant that is returned to the compressor, which will aid in minimizing pressure drops caused by long line lengths.

In order to maintain target head pressure, the outdoor unit fan speed varies: The fan speed increases to reduce head pressure and decreases to increase head pressure. Conditions, such as low load, low ambient, and limited indoor unit capacity request, can occur and may prevent the outdoor unit fan from running.

Indoor unit EEVs will meter refrigerant to maintain target EVA_{in} temperatures set by the outdoor unit option settings. The outdoor unit will also dynamically change the target suction pressure based on the average EVA_{in} temperature of the operating indoor units.

The outdoor unit will speed up or slow down the compressor to meet the target suction pressure: As the suction pressure decreases to below target, the compressor slows down to increase suction pressure. As the pressure increases to above target, the compressor speeds up to decrease suction pressure.

Example

Figure 74 and Table 4 give an example that uses specific conditions (outdoor temperature -5°F to 50°F, return air temperature 64°F to 77°F). This example is not to be used for judgment in all cases. If the ambient or return air temperature is outside of typical cooling, the values will be different.

Figure 74. Example of a system operating in Cooling mode: Ideal temperatures and target temperatures, based on ambient conditions

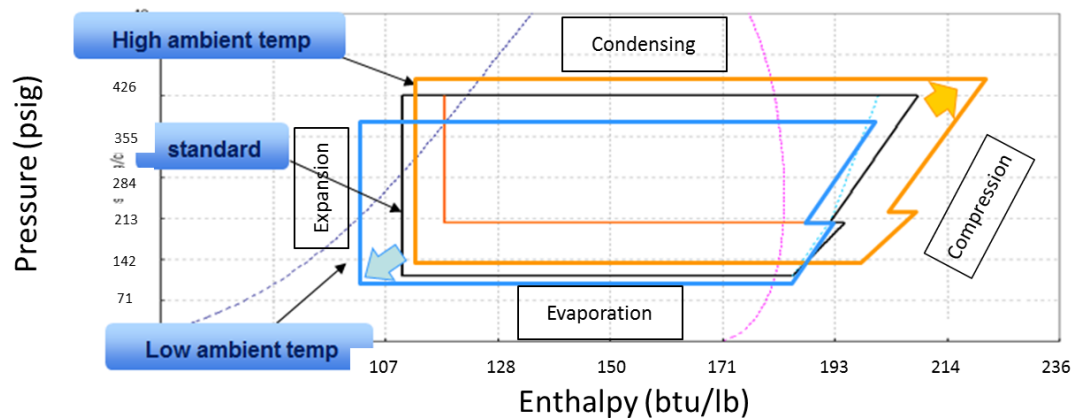

Table 4. Approximate operating temperatures and pressures at low, standard, and high ambient conditions: Cooling mode

Item	Low ambient	Normal	Checkpoint	High ambient
Low pressure	Standard or lower	85.3-135 psig	<ul style="list-style-type: none"> The low pressure will normally vary from 85-135 psig according to piping length and target low pressure. When the ambient temperature is high or the indoor load is big, the low pressure may be higher. High pressure will rise when the ambient temperature rises (maximum: 512 psig) When the ambient temperature decreases, high pressure may decrease as well. If pressure is higher than 355 psig but discharge temperature is lower than 140°F (DSH lower than 36°F), check for leaking ESC EEV, PHE, indoor unit EEV opening error, indoor unit fan operation error. Condensing temperature will change based on high pressure. Condensing temperature - liquid tube temperature = subcooling (normal 41°F-68°F). 	Standard or higher
High pressure		355-469 psig		
Compressor discharge temperature		140-221°F		
Condensing temperature		95-131°F		
Liquid tube temperature		77-122°F		

Indoor Unit Fan Operation in Cooling Mode

When the fan speed is set to Auto, the fan will run at a speed that is dependent on the indoor unit space temperature ΔT from setpoint (see Table 5 and the indoor unit sequence of operation section for more details).

Table 5. Indoor unit target: Cooling mode

Item	Low ambient	Normal	Checkpoint	High ambient
EVA _{in} temperature	Standard or lower	44–57°F	<ul style="list-style-type: none"> • Check target EVA_{in} temperature in outdoor unit option setting (cooling capacity correction) Default: EVA_{in} 44°F–48°F, Superheat = EVA_{out} – EVA_{in} = 3°F–7°F (normal) • Refrigerant undercharge quick check: With all indoor units operating, if over 50% of indoor units have superheat of over 9°F and the indoor unit EEV steps are over 900 (for high wall EEV: 1300 steps), the system is undercharged. • Refrigerant overcharge quick check: With all indoor units operating and room temperature is over 77°F, the majority of indoor units have superheat of 0–1°F and the indoor unit EEV steps are less than 200 (high wall unit EEV steps: 300), the system is overcharged. OR If only a few indoor unit EEV steps approach maximum, check the pipe length from the first branch pipe to indoor unit (limited to 147 ft) and ensure that there is no refrigerant flow restriction. 	Standard or higher
EVA _{out} temperature		44–57°F		
EEV step of indoor unit		250–900 steps		

When the fan speed is manually set to low, medium, or high from the controller, the fan will run continuously at the set speed regardless of the indoor unit space temperature ΔT from setpoint.

Heating Mode

Note: The following sequence is based on a two-compressor system. For single-compressor systems, disregard references to a second compressor.

Compressor Starting Sequence

Upon a call for heating from an indoor unit, a safety start is implemented for upwards of 12 minutes ensure an optimal system start. During this time, and before the compressor starts, a logic judgment is made on how best to safely start the system based on the requested capacity and outdoor ambient temperature while preventing liquid floodback to the compressors.

After the judgment is complete, any enabled MCU EEVs are at 0 steps. The indoor unit EEV will open to 960 steps for the duration of safety start. EVI solenoid 1 and EVI solenoid 2 open. The main EEV opens to 1200 steps. The EVI bypass solenoid energizes. The HGBP 1 energizes. The crankcase heaters energize if power has not been applied for more than 12 hours prior to start.

Just before the compressor starts, the MCU heating solenoids energize open and all offline indoor unit EEVs in Heating mode go to between 80–230 steps. The number of steps is dependent on compressor Hz. This dependency prevents hoarding of refrigerant and oil in units that are not actively heating.

When the designated main compressor starts, but still is in a Safety Start mode, a logic judgment is made on best to safely start the system and prevent liquid floodback to the compressors.

Figure 75. System start-up flow chart

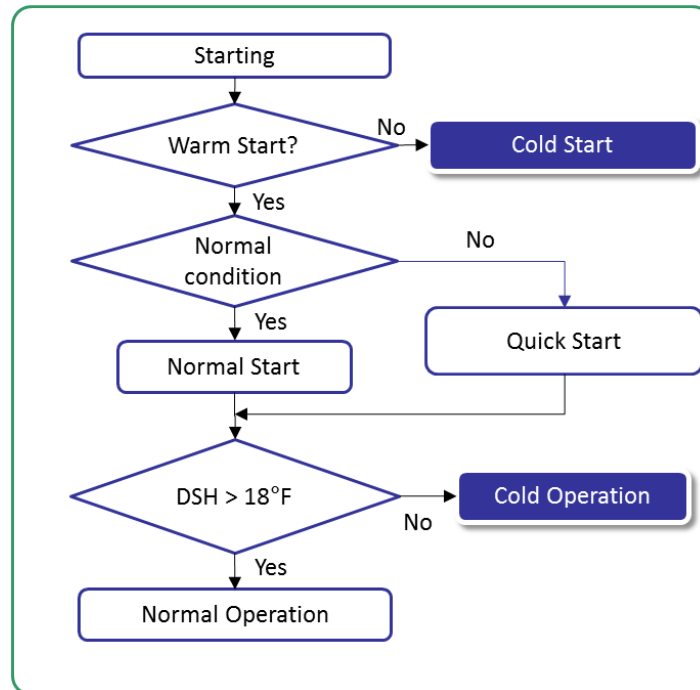

After the judgment is complete, the offline compressor EVI solenoid closes. While still in a Safety Start mode, the second compressor starts and the EVI solenoid associated with that compressor energizes. After 27°F DSH is achieved, the system exits the Safety Start mode and the HGBP 1 valve de-energizes. If necessary, the HGBP 1 will energize during abnormally low suction pressure during normal operation in Heating mode. If the suction pressure falls below 19 psig suction pressure, the HGBP 1 will energize. It will then de-energize at 34 psig suction pressure.

Normal Start

Outdoor Unit

After the release to a normal start, all compressors will start in both single unit or module systems. If capacity request does not meet the need of having multiple compressors running, any unnecessary compressors and associated valves will shut down when their minimum run timers expire. If capacity request dictates that multiple compressors are required, the required compressors will continue to run.

The outdoor unit will speed up or slow down compressor(s) to meet the target high pressure set by the outdoor unit. As the pressure decreases below target, the compressor will speed up to increase head pressure. When the pressure increases above target, the compressor slows down to decrease head pressure. In response, the EVA_{out} temperatures at the indoor unit coil increase or decrease.

In order to maintain target suction pressure, the outdoor unit fan speed varies: The fan speed increases to reduce head pressure and decreases to increase head pressure. The lower the ambient temperature, the faster the outdoor unit fan will run. Conditions can occur that prevent the outdoor unit fan from running.

Example

Figure 76 and Table 6 give an example that uses specific conditions (outdoor temperature -5°F to 50°F , return air temperature 64°F to 77°F). This example is not to be used for judgment in all cases. If the ambient or return air temperature is outside of typical heating, the values will be different.

Figure 76. Example of a system operating in Heating mode: Ideal temperatures and target temperatures, based on ambient conditions

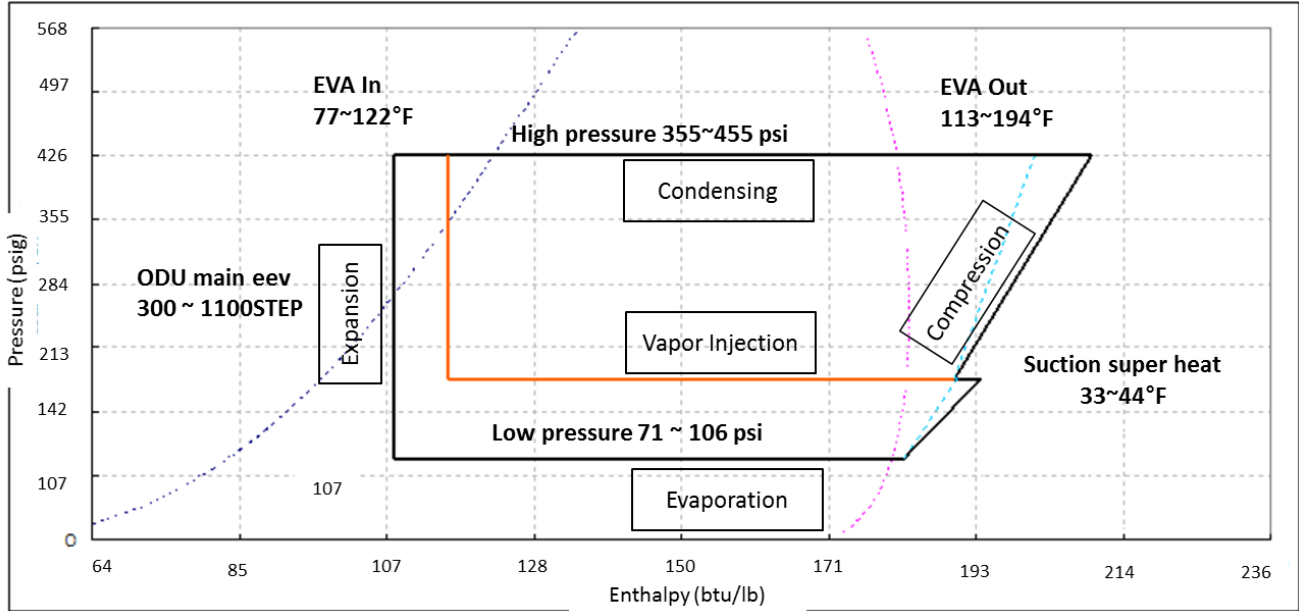

Table 6. Approximate operating temperatures and pressures at low, standard, and high ambient conditions: Heating mode

Item	Normal	Checkpoint
High pressure	355-455 psig	<ul style="list-style-type: none"> High pressure can be lower than normal when the ambient temperature is lower than 32°F, the heat load design is incorrect, or the return air temperature is lower than 68°F. Note: Low pressure is just a reference value, because it can be affected by ambient temperature.
Low pressure	71-106 psig	
Compressor discharge temperature	149-221°F	<ul style="list-style-type: none"> If all indoor units are operating and both conditions listed below are satisfied, the temperature may be normal: <ul style="list-style-type: none"> - DSH (discharge temperature - high pressure saturated temperature) $\geq 36^\circ\text{F}$ - Maximum discharge temperature $\leq 221^\circ\text{F}$
Suction	33-44°F	<ul style="list-style-type: none"> If suction superheat is not satisfied, verify that outdoor unit main EEV is working. If outdoor unit main EEV step is maximum and superheat is high, check for an undercharged system.

Indoor Unit Fan Operation in Heating Mode

When the fan speed is set to Auto, the fan will run at a speed that is dependent on the indoor unit space temperature ΔT from setpoint (see [Table 7](#) and the indoor unit sequence of operation section for more details.)

Table 7. Indoor unit target: Heating mode

Item	Normal	Checkpoint
EVA _{out} temperature	113–194°F	<ul style="list-style-type: none"> Can be normal if EVA_{out} temperatures are satisfied below this range. <ul style="list-style-type: none"> - Discharge air 55°F higher than room temperature (46°F for ducted models). - EVA_{out} temperature is no more than 62°F ΔT from high-pressure saturated temperature (71°F for ducted model). If all indoor units have EVA_{in} temperature lower than 91°F or the high pressure is lower than 355 psig, check if ambient temperature is lower than 23°F and check load design for heating. Incorrect load design or refrigerant overcharge can be the cause. If only a few indoor units have lower than normal EEV_{in} temperatures, check the pipe length from the first branch joint to indoor unit (limited to 147 ft) and ensure that no refrigerant flow restriction exists.
EVA _{in} temperature	91–122°F	
EEV step of indoor unit	600–1500 steps	

Fan speed set to Auto in Heating mode differs from Auto in Cooling mode in the following way only: Upon initial start in heating mode or upon a change from cooling mode to heating mode, the fan will not start until the average of the EVA_{in} and EVA_{out} temperatures for an indoor unit is above 82°F. The purpose of this limit is to prevent cold air from blowing on the occupant ([Figure 77](#)).

Figure 77. Initial start in heating mode or when changing from cooling to heating mode.

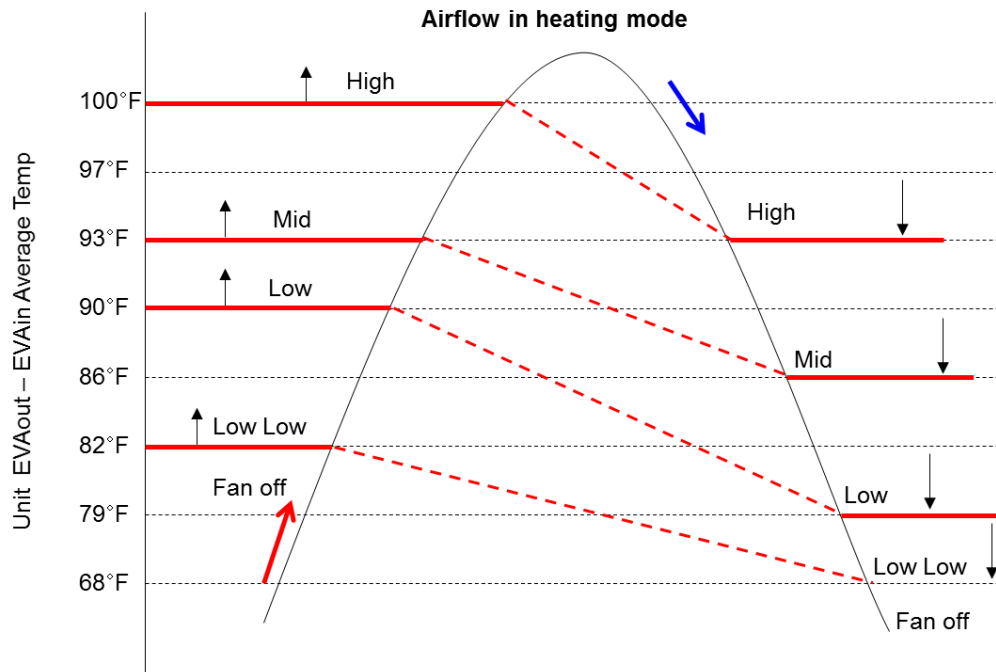

When the fan speed is manually set to low, medium or high from the controller, the fan will run continuously in low, medium or high speed regardless of the indoor unit(s) space temperature ΔT from setpoint.

Mainly Cooling Mode (Heat Recovery Units Only)

When a capacity request is initiated by the indoor unit(s) for mixed mode of operation where the majority of the capacity request is for cooling, the outdoor unit will start in Mainly Cooling Mode. System start-up will follow the sequence of Cooling only mode with the exception that indoor units requesting heat will energize the heating solenoid in the associated MCU.

Mainly Heating Mode (Heat Recovery Units Only)

When a capacity request is initiated by the indoor unit(s) for mixed mode of operation where the majority of the capacity request is for heating, the outdoor unit will start in Mainly Heating Mode. System start-up will follow the sequence of Heating only mode with the exception that indoor units requesting cool will energize the cooling solenoid in the associated MCU.

Mode Change: Heat Pump System

Mode change for a heat pump unit is limited. At start up, in either 100% Heating or 100% Cooling Mode, the outdoor unit is limited to that specific mode of operation and an opposite mode of operation cannot be selected from another controller or indoor unit without shutting the system down. Removal of the heat pump limit is accomplished in one of three ways, as described below.

Manual

- Turn off all indoor units.
- Turn one indoor unit on and set a new mode.
- Changes mode of operation to that system.
- Turn on any remaining units in the new mode.
- This will change the mode of operation of a heat pump system.

Time and manual

- All indoor units have transitioned to thermal off (satisfied).
- A 30-minute timer expires with no new call.
- The opposite mode is manually shifted to the opposite mode at the wired controller or through an upper level controller.

Release of mode restriction through upper level controller(s)

- VRF System Controller (see controller sequence of operation section for details).
- Touchscreen (see controller sequence of operation section for details).

Mode Change: Heat Recovery System

The Criterion of Heat Capacity Ratio (HCR) is used for mode changeover on a heat recovery system. The ratio is represented by the line in Figure 34, which is based on the indoor cooling temperature, the indoor heating temperature, and the operation capacity ratio of the indoor units that are operating. This line is continually changing. If the HCR is above the line, the mode will change from Mainly Cooling to Mainly Heating. If the HCR is below the line, the mode will change from Mainly Heating to Mainly Cooling.

$$\text{Heating Capacity Ratio (HCR)} = \frac{\Sigma(\text{Heating})}{\{\Sigma(\text{Heating}) + \Sigma(\text{Cooling})\}}$$

which says that the HCR is equal to the sum of the indoor units in Heating mode divided by the sum of the total units operating in Heating mode and Cooling mode.

For example, if:

- the average heating indoor room temperature is 68°F
- the average cooling indoor room temperature is 75°F

- the indoor operating ratio is at 50%

The Criterion of HCR becomes a straight line on a graph where the HCR is the y-axis and the outdoor temperature is the x-axis (see Figure 78).

Figure 78. Criterion of HRC example

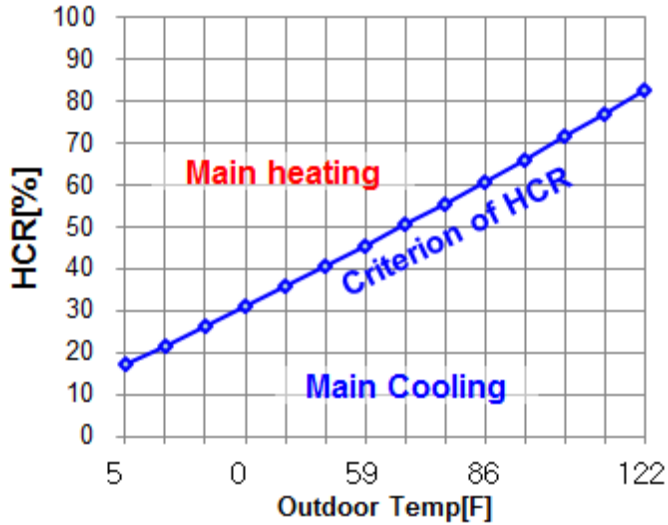

So, if the HCR is within 20% of the Criterion of HCR for 30 minutes while running in Mainly Heating, the unit will change mode to Mainly Cooling. The opposite is true when running in Mainly Cooling. If the HCR is within 15% of the Criterion of HCR for 30 minutes, the unit will change to Mainly Heating. If the HCR has exceeded the Criterion for HCR, changeover will disregard the 30-minute timer and the changeover will take place. (See Figure 79.)

Figure 79. Mode changeover

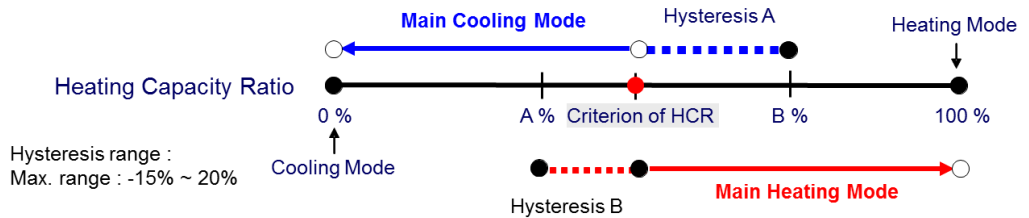

Special Operations

Oil Recovery Mode

Oil Recovery mode is used to bring any oil trapped in the system back to the compressor(s). In the absence of an oil-equalizing line, Oil Recovery is accomplished using a logic-based algorithm. This algorithm is based on system operating time and compressor Hz. The slower compressor Hz, the sooner an Oil Recovery cycle is initiated. The faster compressor Hz, the longer the time between cycles. The Oil Recovery mode can take place at any point between 40 minutes to 7 hours and will last 3 minutes in Cooling mode and 6 minutes in Heating mode. Not all compressors will run during the Oil Recovery cycle. The number of compressors that will run is based on the current capacity request plus 10%. If based on the additional 10%, another compressor is required. The system will start and run all compressors at capacity plus 10% or a minimum of 20 Hz. If the system is operating in Heating mode and a defrost cycle takes place between Oil Recovery cycles and lasts for longer than 3 minutes, this operation is considered to be an Oil Recovery cycle. Consequently, the cycle

timer is reset. After the Oil Recovery cycle has completed, the outdoor unit that has operated the least in the last 60 minutes will become the master outdoor unit (for details, see "Outdoor Unit and Compressor Operating Priority" in the outdoor unit sequence of operations section).

When Oil Recovery is initiated in Cooling mode, the indoor unit EEV(s) go to a minimum of 400 steps or stay the same if already above minimum steps. If the unit is in thermo off, its EEV will go to 400 steps.

When Oil Recovery is initiated in Heating mode, the indoor unit EEV(s) go to a minimum of 300 steps or stay the same if already above minimum steps. If the unit is in thermo off, its EEV will go to 300 steps.

Intelligent Defrost

Used to remove frost and ice from the outdoor unit coil to minimize capacity loss. Intelligent Defrost is a logic-based defrost cycle utilizing temperature, time, and airflow through the outdoor coil to initiate a defrost cycle. Condenser out temperature is utilized to terminate the defrost cycle. Maximum defrost cycle time is 12 minutes. Intelligent defrost functions with both heat pump and heat recovery systems.

For heat recovery module systems only, intelligent defrost operates as rotational defrost. It must be set using the outdoor unit option codes.

When rotational defrost is operating, one outdoor unit transitions to defrost while the other outdoor unit(s) continue to actively heat. To accomplish one defrost cycle, two rotations must complete for a system with two outdoor units, and three rotations must complete for a system with three outdoor units.

Figure 80. Rotational defrost cycle with three outdoor units

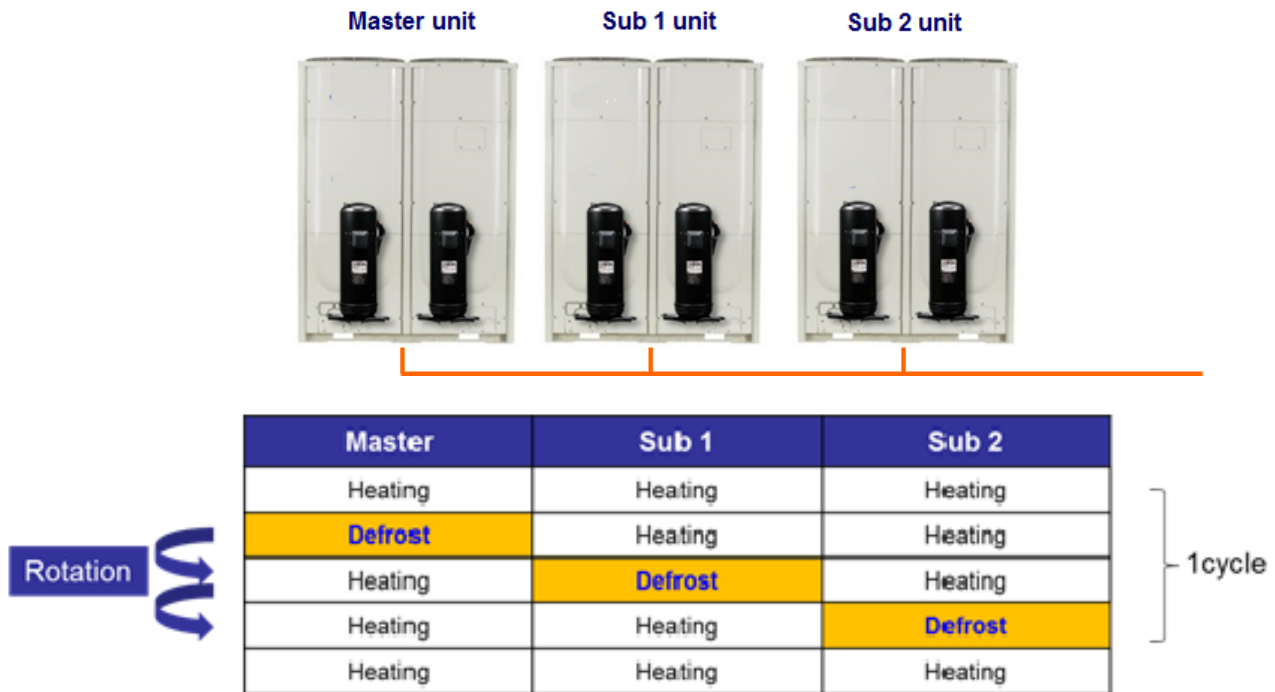

During rotational defrost, hot gas from the outdoor unit(s) in Heating mode is supplied to the indoor unit for uninterrupted heating operation. Suction gas is pulled from the actively heating outdoor units to the outdoor unit in defrost to provide refrigerant back to the compressor for conversion to

hot gas and to defrost the coil. The liquid that is produced by the unit in defrost is sent to the outdoor unit(s) that are actively heating to compensate for the reduction in suction gas.

Figure 81. Rotational defrost cycle diagram

◆ Defrost operation (R-defrost)

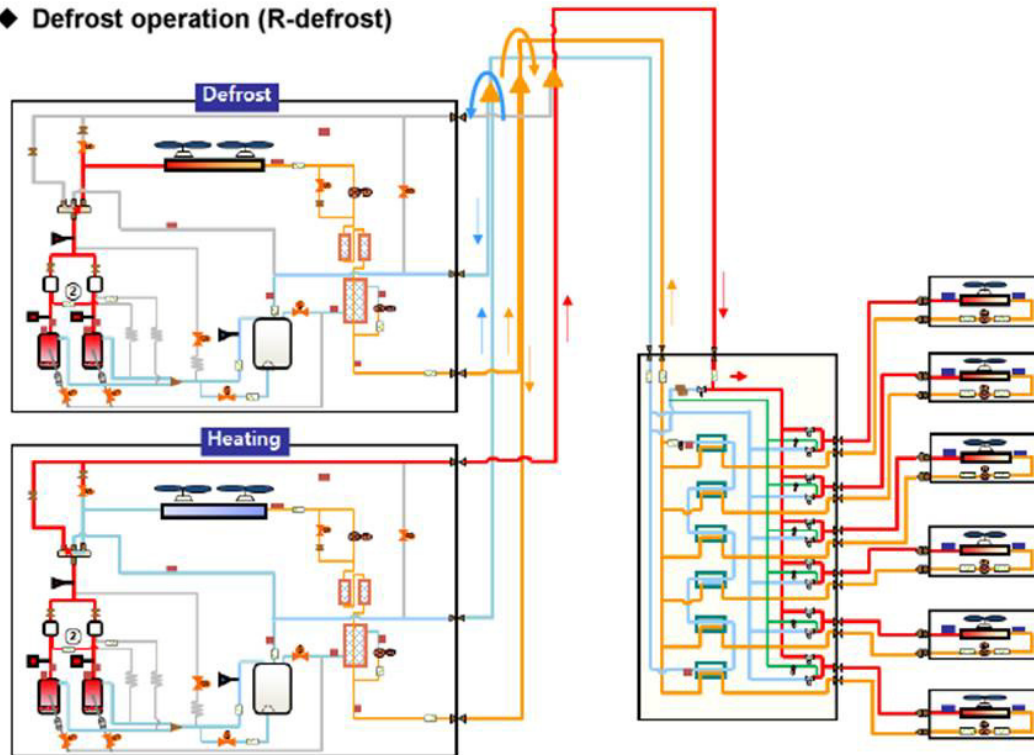

Pump Down/Out

A process used to minimize refrigerant shortage and liquid floodback at the outdoor unit during the start-up and shutdown routine. This process lasts for approximately 60 seconds at initial safety start. It is part of the stop routine before compressor shutdown.

In Cooling mode, the indoor unit EEV closes while the compressor continues to run in order to pump down refrigerant in the indoor unit coil. In Heating mode, the main EEV closes when the compressor starts to pump out refrigerant from the condenser.

Figure 82. Pump down/out process

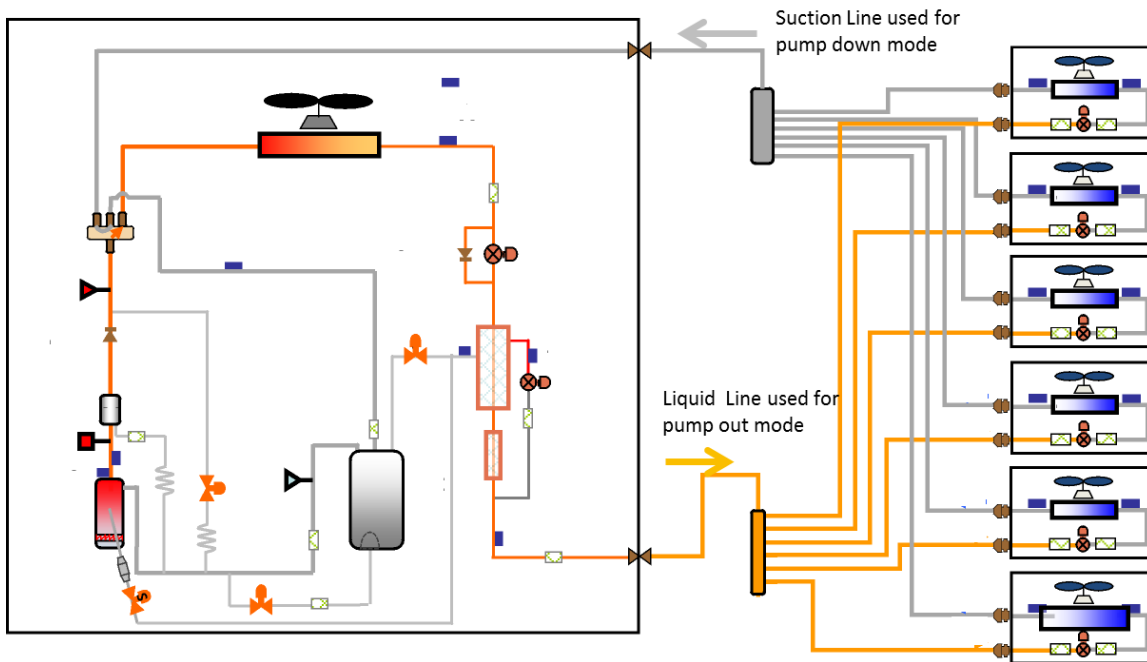

Freeze Protection

Used to prevent an indoor unit coil from freezing up during operation. The logic is as follows: If the EVA_{in} temperature of any one indoor unit falls below 35°F for 40 seconds, the outdoor unit initiates an Hz hold on compressor frequency. If the EVA_{in} temp of any indoor unit falls below 32°F for 40 seconds, the outdoor unit begins to drop compressor Hz by 5 Hz every 20 seconds. If the EVA_{in} on any indoor unit falls below 28°F for 40 seconds, target cooling capacity is reduced. If the EVA_{in} continues to fall to 24°F for 3 minutes, the outdoor unit will shut down. It will remain shut down until the EVA_{in} temperature rises to 44°F. There is no error code if the system shuts down.

Figure 83. Freeze Protection flow chart

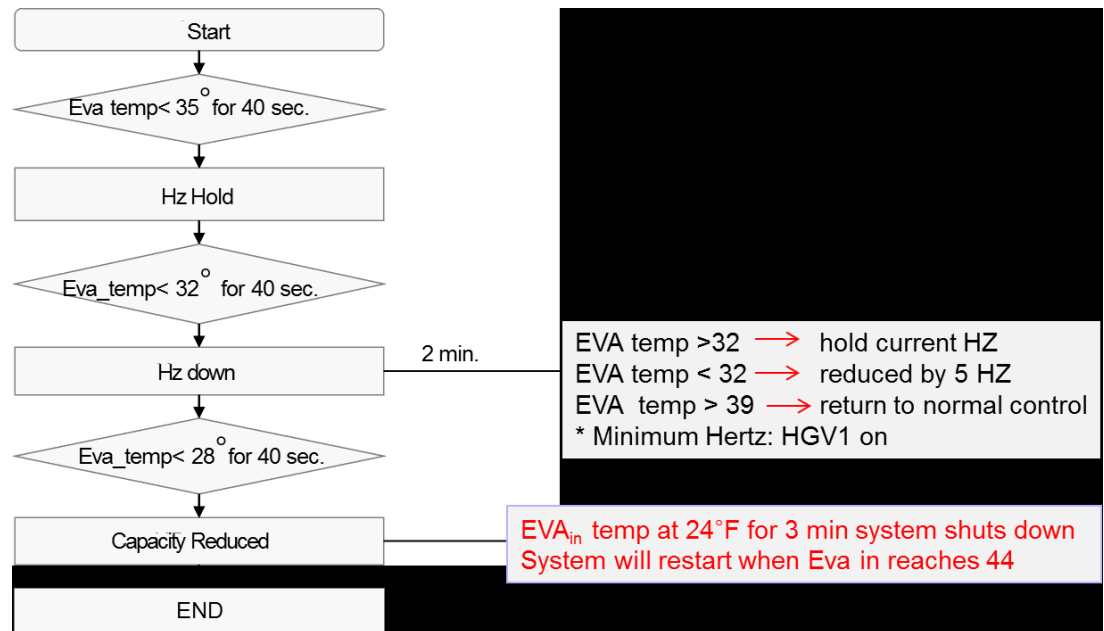

Safety Start

Safety start is a process that protects the VRF system during start-up. A series of judgments that minimize compressor maximum Hz and the rate at which the frequency increases helps to prevent liquid refrigerant from overflowing the accumulator and slugging the compressor. Safety start consists of a pump down, soft start, mild start, cold operation, and, ultimately, normal operation.

Mild Start

Mild start is the 2-minute settle-out period at the end of the safety start.

Cold Start

Cold start is based on (A or B) + C + D where:

- A. Higher of (CTT or CDT) – ODT < 27°F temperature at start up
- B. Or the higher of CTT and CDT < 122°F
- C. And power applied less than 12 hours before start
- D. And ambient temperature less than
 - a. 68°F in heating
 - b. 86°F in cooling

Figure 84. Cold start

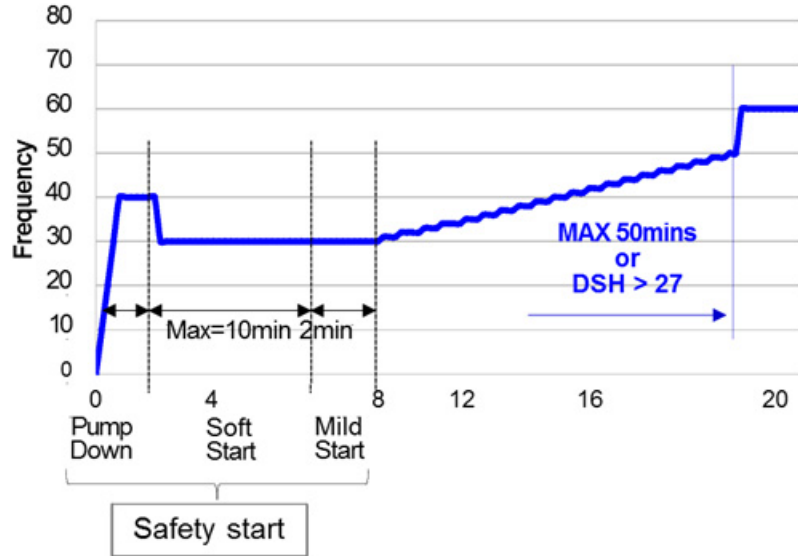

This start-up procedure lasts until discharge superheat (DSH) is > 27°F or for a maximum of 50 minutes run time. Limiting the maximum frequency and the speed at which the compressor increases will minimize oil foaming and ensure proper oil levels in the compressor.

Cold Operation

Cold operation is initiated at the end of soft start if the discharge superheat (DSH) fails to meet the 18°F requirement or the compressor top temperature, or if the compressor discharge temperature fails to make 122°F. Cold operation will run until DSH achieves 27°F or for a maximum of 30 minutes.

Figure 85. Cold Operation

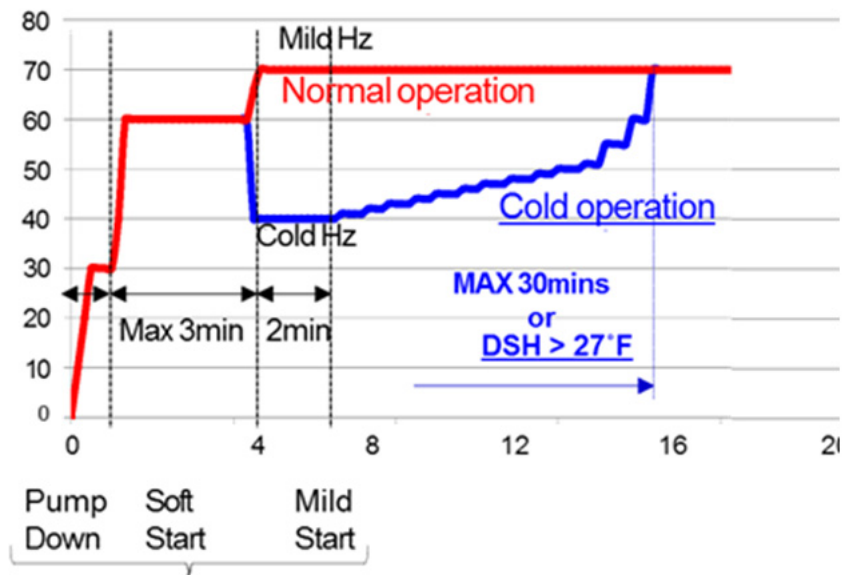

Normal Start

Normal start begins after safety start has completed its judgment routine.

Figure 86. Normal start flow chart

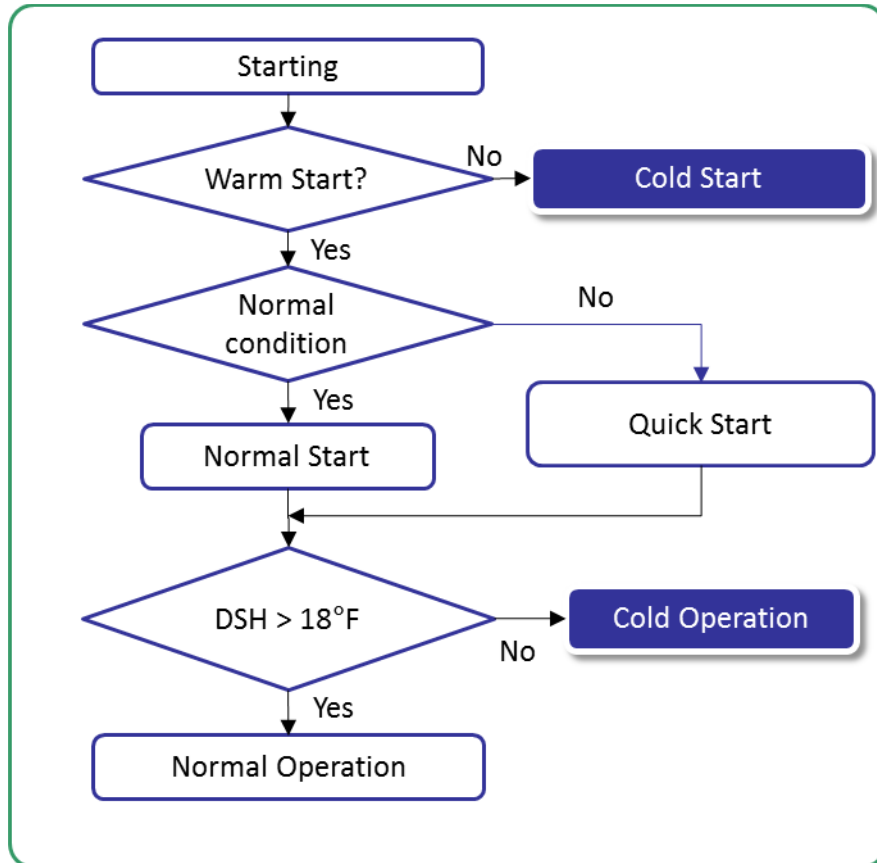

Quick Start

At start up, with a 30% or greater capacity request from the indoor unit(s), all compressors will start in the requested mode of operation. Quick start is allowed within the operating envelope. A quick start does not override the need to do a cold start. A cold start has higher priority than a quick start.

Figure 87. Quick start graph

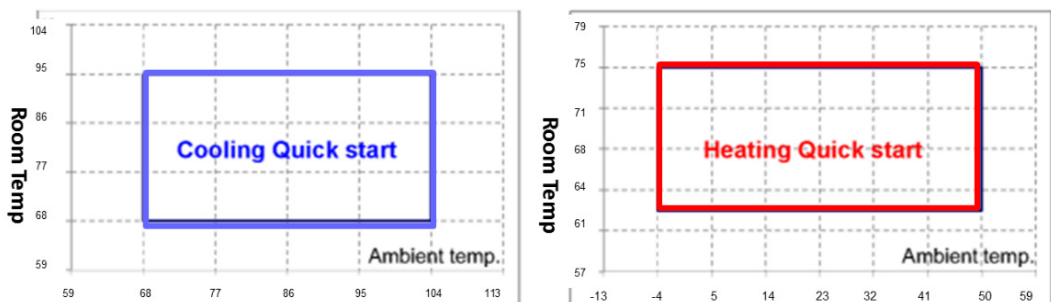

Low Ambient Cooling

Cooling start in low ambient conditions is rated to 23°F. If low ambient cooling is required during these temperatures, the “expanded operational temperature range for cooling” option setting (option 12) on the outdoor unit must be set (for heat recovery only). Also, two MCU ports must be utilized for any indoor unit between 18-48 MBh to achieve low ambient cooling operation below 23°F.

Discharge Air Control

Refers to the ability to control the discharge air temperature from a ducted indoor unit or a unit that has an installed AHU kit while maintaining the space temperature setpoint. While the indoor unit is actively heating or cooling, the end user can set a discharge air temperature setpoint and a space temperature setpoint. The thermal on/thermal off of the unit will be based on the desired space temperature setpoint relationship to the space temperature while the discharge air setpoint is met.

Discharge air control is possible with the following conditions:

- Only with ducted indoor units or units with installed AHU kits. Systems can contain a mixture of these unit types.
- Any units on the system that are not ducted or AHU must be thermo off.
- Units must be operating in Cooling Only or Heating Only mode.
- For heat pump systems: 1-to-1 only.

Auto-Commissioning Mode

Releases the VRF system from unprepared (UP).

Note: *Unprepared refers to the period of time when tracking is finished and the system is ready for auto-commissioning, but it is not ready to run.*

By pressing K1 for 5 seconds on the outdoor unit main control board, the system will commission using a predetermined algorithm. It will last approximately 1 hour or less depending on system size and total indoor units. After completion, the system is ready for comfort heating and cooling control.

The seven segment display will scroll addresses for the indoor units (for both HP and HR) and the MCUs (HR only).

Ingersoll Rand (NYSE:IR) advances the quality of life by creating comfortable, sustainable and efficient environments. Our people and our family of brands—including Club Car®, Ingersoll Rand®, Thermo King® and Trane®—work together to enhance the quality and comfort of air in homes and buildings; transport and protect food and perishables; and increase industrial productivity and efficiency. We are a global business committed to a world of sustainable progress and enduring results. For more information, visit www.ingersollrand.com.

Ingersoll Rand has a policy of continuous product and product data improvement and reserves the right to change design and specifications without notice.