

- NOTES:
- UNLESS OTHERWISE NOTED ALL SWITCHES ARE SHOWN AT 25°C (77°F), AT ATMOSPHERIC PRESSURE, AT 50% RELATIVE HUMIDITY, WITH ALL UTILITIES TURNED OFF, AND AFTER A NORMAL SHUTDOWN HAS OCCURRED.
 - DASHED LINES INDICATE RECOMMENDED FIELD WIRING BY OTHERS. DASHED LINES ENCLOSURES AND/OR DASHED LINES OUTLINES INDICATE COMPONENTS PROVIDED BY THE FIELD. PHANTOM LINES INDICATE CONTROL OPTION. PHANTOM LINES ENCLOSURES INDICATE ALTERNATE CIRCUITRY OR AVAILABLE SALES OPTIONS. SOLID LINES INDICATE WIRING BY TRANE.
 - AN UNDERLINED NUMBER INDICATES A NORMALLY CLOSED CONTACT, AN OPEN ARROWHEAD BELOW THE LINE NUMBER POINTING UPWARD INDICATES A TIMED CONTACT WHICH BEGINS TIMING WHEN ENERGIZED.
 - ALL FIELD WIRING MUST BE IN ACCORDANCE WITH THE NATIONAL ELECTRICAL CODE, STATE, AND LOCAL REQUIREMENTS. OTHER COUNTRIES APPLICABLE NATIONAL AND/OR LOCAL REQUIREMENTS SHALL APPLY. FIELD CONDUCTORS SHALL HAVE INSULATION RATING NOT LESS THAN 600V COPPER CONDUCTORS ONLY.

- CONNECTIONS ARE INTENDED FOR CLASS 2 ONLY.
- ALL AVAILABLE END DEVICES SHOWN. SEE UNIT CONFIGURATION FOR END DEVICES ON UNIT.
- USE INSET A WHEN UNIT HAS THREE SUPPLY FANS.
- USE INSET B WHEN R32 BEEN USED.

AREA	LOCATION
1	MAIN CONTROL PANEL
2	SUPPLY FAN&COIL SECTION
3	ELECTRIC HEAT CONTROL BOX
4	FILTER SECTION
5	MIXING BOX SECTION
6	COIL ACCESS SECTION
7	EXTERNAL PIPING
8	FIELD INSTALLED DEVICE
9	VFD CONTROL PANEL

DEVICE	DESCRIPTION
1W1	ADAPTER BOARD
2M1	SUPPLY FAN 1
2M2	SUPPLY FAN 2
2M3	SUPPLY FAN 3
2R1	MIXED AIR SENSOR
2R2	DISCHARGE AIR SENSOR
2S1	LOW LIMIT SWITCH
2S2	CONDENSATE OVERFLOW SWITCH
2S3	FAN STATUS SWITCH
2S4	FILTER STATUS SWITCH
2S5	LEAK DETECTION SENSOR (R454B,R32)
5M1	DAMPER ACTUATOR

CAUTION
 USE COPPER CONDUCTORS ONLY!
 UNIT TERMINALS ARE NOT DESIGNED TO ACCEPT OTHER TYPES OF CONDUCTORS.
 FAILURE TO DO SO MAY CAUSE DAMAGE TO THE EQUIPMENT.

ATTENTION
 N'UTILISER QUE DES CONDUCTEURS EN CUIVRE!
 LES BORNES DE L'UNITÉ NE SONT PAS CONÇUES POUR RECEVOIR D'AUTRES TYPES DE CONDUCTEURS.
 L'UTILISATION DE TOUT AUTRE CONDUCTEUR PEUT ENDOMMAGER L'ÉQUIPEMENT.

PRECAUCIÓN
 ¡UTILICE ÚNICAMENTE CONDUCTORES DE COBRE!
 LAS TERMINALES DE LA UNIDAD NO ESTÁN DISEÑADAS PARA ACEPTAR OTROS TIPOS DE CONDUCTORES.
 SI NO LO HACE, PUEDE OCASIONAR DAÑO AL EQUIPO.

WARNING
 HAZARDOUS VOLTAGE!
 DISCONNECT ALL ELECTRIC POWER INCLUDING REMOTE DISCONNECTS AND FOLLOW LOCK OUT AND TAG PROCEDURES BEFORE SERVICING. INSURE THAT ALL MOTOR CAPACITORS HAVE DISCHARGED STORED VOLTAGE. UNITS WITH VARIABLE SPEED DRIVE, REFER TO DRIVE INSTRUCTIONS FOR CAPACITOR DISCHARGE. FAILURE TO DO THE ABOVE BEFORE SERVICING COULD RESULT IN DEATH OR SERIOUS INJURY.

AVERTISSEMENT
 TENSION DANGEREUSE!
 COUPER TOUTES LES TENSIONS ET OUVRIER LES SECTIONNEURS A DISTANCE, PUIS SUIVRE LES PROCÉDURES DE VERROUILLAGE ET DES ÉTIQUETTES AVANT TOUTE INTERVENTION. VÉRIFIER QUE TOUTS LES CONDENSATEURS DES MOTEURS SONT DÉCHARGÉS. DANS LE CAS D'UNITÉS COMPORTANT DES ENTRAÎNEMENTS À VITESSE VARIABLE, SE REPORTER AUX INSTRUCTIONS DE L'ENTRAÎNEMENT POUR DÉCHARGER LES CONDENSATEURS.

ADVERTENCIA
 ¡VOLTAJE PELIGROSO!
 DESCONECTE TODA LA ENERGÍA ELÉCTRICA, INCLUIDO LAS SECCIONNEURS REMOTOS Y SIGA LOS PROCEDIMIENTOS DE CIERRE Y ETIQUETADO ANTES DE PROCEDER AL SERVICIO. ASEGURESE DE QUE TODOS LOS CAPACITORES DEL MOTOR HAYAN DESCARGADO EL VOLTAJE ALMACENADO. PARA LAS UNIDADES CON EJE DE DIRECCIÓN DE VELOCIDAD VARIABLE, CONSULTE LAS INSTRUCCIONES PARA LA DESCARGA DEL CONDENSADOR. EL NO REALIZAR LO ANTERIORMENTE INDICADO, PODRÁ OCASIONAR LA MUERTE O SERIAS LESIONES PERSONALES.

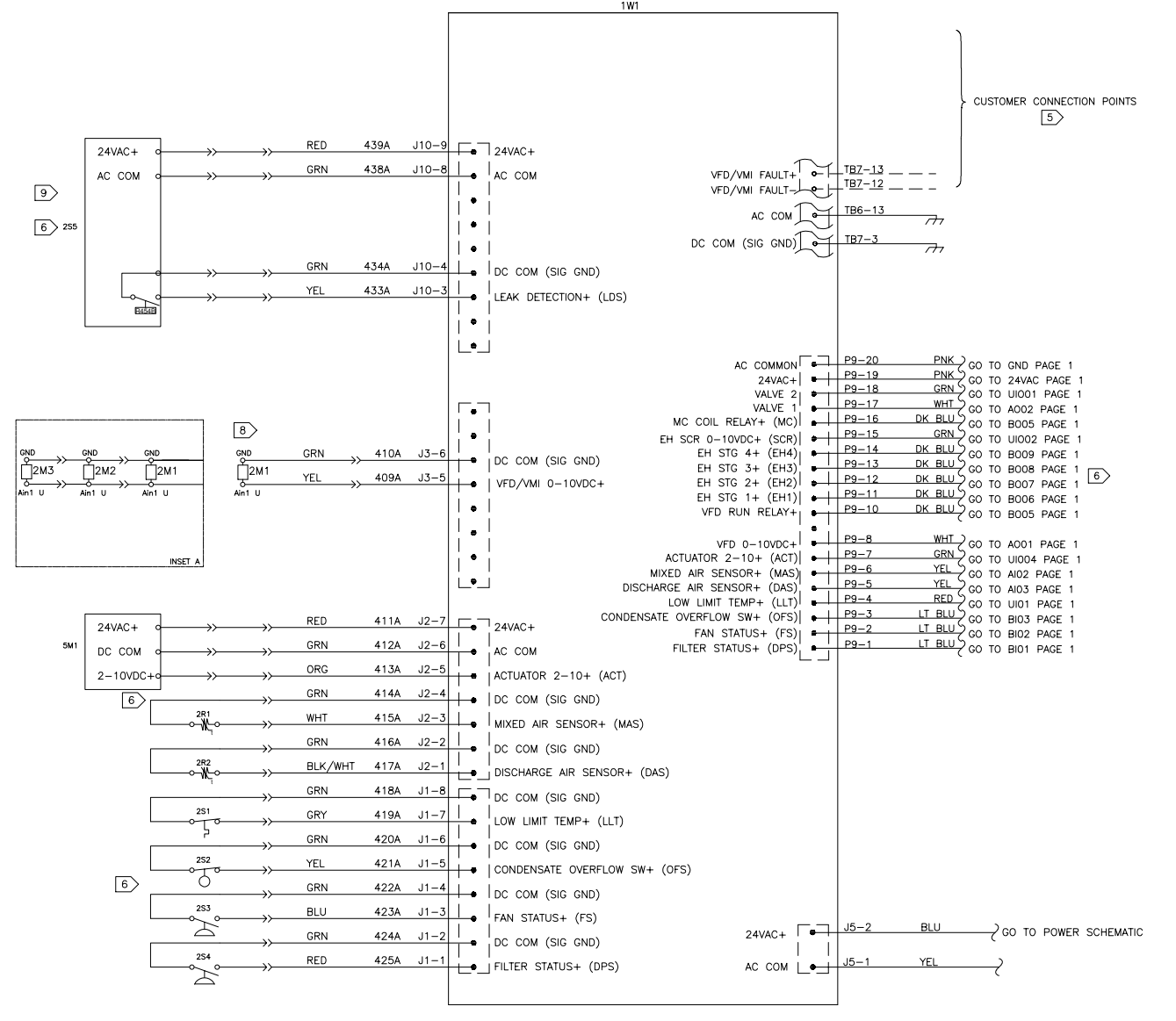
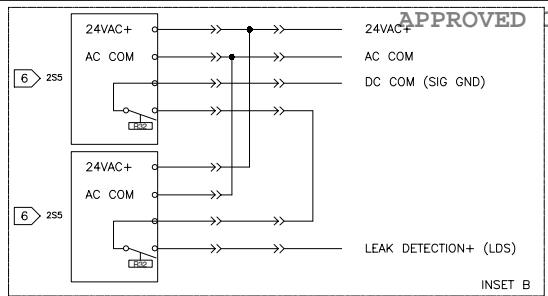

- NOTES:
- UNLESS OTHERWISE NOTED ALL SWITCHES ARE SHOWN AT 25°C (77°F), AT ATMOSPHERIC PRESSURE, AT 50% RELATIVE HUMIDITY, WITH ALL UTILITIES TURNED OFF, AND AFTER A NORMAL SHUTDOWN HAS OCCURRED.
 - DASHED LINES INDICATE RECOMMENDED FIELD WIRING BY OTHERS. DASHED LINES ENCLOSURES AND/OR DASHED DEVICE OUTLINES INDICATE COMPONENTS PROVIDED BY THE FIELD. PHANTOM LINES INDICATE CONTROL OPTION. PHANTOM LINES ENCLOSURES INDICATE ALTERNATE CIRCUITRY OR AVAILABLE SALES OPTIONS. SOLID LINES INDICATE WIRING BY TRANE.
 - AN UNDERLINED NUMBER INDICATES A NORMALLY CLOSED CONTACT. AN OPEN ARROWHEAD BELOW THE LINE NUMBER POINTING UPWARD INDICATES A TIMED CONTACT WHICH BEGINS TIMING WHEN ENERGIZED.
 - ALL FIELD WIRING MUST BE IN ACCORDANCE WITH THE NATIONAL ELECTRICAL CODE, STATE, AND LOCAL REQUIREMENTS. OTHER COUNTRIES APPLICABLE NATIONAL AND/OR LOCAL REQUIREMENTS SHALL APPLY. FIELD CONDUCTORS SHALL HAVE INSULATION RATING NOT LESS THAN 600V COPPER CONDUCTORS ONLY.
- 5 CONNECTIONS ARE INTENDED FOR CLASS 2 ONLY.
- 6 ALL AVAILABLE END DEVICES SHOWN. SEE UNIT CONFIGURATION FOR END DEVICES ON UNIT.
- 8 USE INSET A WHEN UNIT HAS THREE SUPPLY FANS.
- 9 USE INSET B WHEN R32 BEEN USED.

AREA	DEVICE PREFIX	LOCATION CODE	LOCATION
1			MAIN CONTROL PANEL
2			SUPPLY FAN&COIL SECTION
3			ELECTRIC HEAT CONTROL BOX
4			FILTER SECTION
5			MIXING BOX SECTION
6			COIL ACCESS SECTION
7			EXTERNAL PIPING
8			FIELD INSTALLED DEVICE
9			VFD CONTROL PANEL

DEVICE	DESCRIPTION
1W1	ADAPTER BOARD
2M1	SUPPLY FAN 1
2M2	SUPPLY FAN 2
2M3	SUPPLY FAN 3
2R1	MIXED AIR SENSOR
2R2	DISCHARGE AIR SENSOR
2S1	LOW LIMIT SWITCH
2S2	CONDENSATE OVERFLOW SWITCH
2S3	FAN STATUS SWITCH
2S4	FILTER STATUS SWITCH
2S5	LEAK DETECTION SENSOR (R454B,R32)
5M1	DAMPER ACTUATOR

CAUTION
 USE COPPER CONDUCTORS ONLY!
 UNIT TERMINALS ARE NOT DESIGNED TO ACCEPT OTHER TYPES OF CONDUCTORS.
 FAILURE TO DO SO MAY CAUSE DAMAGE TO THE EQUIPMENT.

ATTENTION
 N'UTILISER QUE DES CONDUCTEURS EN CUIVRE!
 LES BORNES DE L'UNITÉ NE SONT PAS CONÇUES POUR RECEVOIR D'AUTRES TIPIES DE CONDUCTEURS.
 L'UTILISATION DE TOUT AUTRE CONDUCTEUR PEUT ENDOMMAGER L'ÉQUIPEMENT.

PRECAUCIÓN
 ¡UTILICE ÚNICAMENTE CONDUCTORES DE COBRE!
 LAS TERMINALES DE LA UNIDAD NO ESTÁN DISEÑADAS PARA ACEPTAR OTROS TIPIOS DE CONDUCTORES.
 SI NO LO HACE, PUEDE OCASIONAR DAÑO AL EQUIPO.

WARNING
 HAZARDOUS VOLTAGE!
 DISCONNECT ALL ELECTRIC POWER INCLUDING REMOTE DISCONNECTS AND FOLLOW LOCK OUT AND TAG PROCEDURES BEFORE SERVICING. INSURE THAT ALL MOTOR CAPACITORS HAVE DISCHARGED STORED VOLTAGE. SERVICING WITH VARIABLE SPEED DRIVE, REFER TO DRIVE INSTRUCTIONS FOR CAPACITOR DISCHARGE. FAILURE TO DO THE ABOVE BEFORE SERVICING COULD RESULT IN DEATH OR SERIOUS INJURY.

AVERTISSEMENT
 TENSION DANGEREUSE!
 COUPER TOUTES LES TENSIONS ET OUVRIER LES SECTIONNEURS A DISTANCE, PUIS SUIVRE LES PROCEDURES DE VERROUILLAGE ET DES ETIQUETTES AVANT TOUTE INTERVENTION. VÉRIFIER QUE TOUTS LES CONDENSATEURS DES MOTEURS SONT DÉCHARGÉS. DANS LE CAS D'UNITÉS COMPORTANT DES ENTRAÎNEMENTS À VITESSE VARIABLE, SE REPORTER AUX INSTRUCTIONS DE L'ENTRAÎNEMENT POUR DÉCHARGER LES CONDENSATEURS.

ADVERTENCIA
 ¡VOLTAJE PELIGROSO!
 DESCONECTE TODA LA ENERGÍA ELÉCTRICA, INCLUIDO LOS SECCIONNEURS REMOTOS Y SIGA LOS PROCEDIMIENTOS DE CIERRE Y ETIQUETADO ANTES DE PROCEDER AL SERVICIO. VERIFIQUE QUE TODOS LOS CAPACITORES DEL MOTOR HAYAN DESCARGADO EL VOLTAJE ALMACENADO. PARA LAS UNIDADES CON EJE DE DIRECCIÓN DE VELOCIDAD VARIABLE, CONSULTE LAS INSTRUCCIONES PARA LA DESCARGA DEL CONDENSADOR. EL NO REALIZAR LO ANTERIORMENTE INDICADO, PODRÁ OCASIONAR LA MUERTE O SERIAS LESIONES PERSONALES.