

NOTES:

- UNLESS OTHERWISE NOTED ALL SWITCHES ARE SHOWN AT 25°C (77°F), AT ATMOSPHERIC PRESSURE, AT 50% RELATIVE HUMIDITY, WITH ALL UTILITIES TURNED OFF, AND AFTER A NORMAL SHUTDOWN HAS OCCURRED.
 - DASHED LINES INDICATE RECOMMENDED FIELD WIRING BY OTHERS. DASHED POWER LINES ENCLOSURES AND/OR DASHED DEVICE OUTLINES INDICATE COMPONENTS PROVIDED BY THE FIELD. PHANTOM LINES INDICATE CONTROL OPTION. PHANTOM LINES ENCLOSURES INDICATE ALTERNATE CIRCUITRY OR AVAILABLE SALES OPTIONS. SOLID LINES INDICATE WIRING BY TRANE.
 - AN UNDERLINED NUMBER INDICATES A NORMALLY CLOSED CONTACT. AN OPEN ARROWHEAD BELOW THE LINE NUMBER POINTING UPWARD INDICATES A TIMED CONTACT WHICH BEGINS TIMING WHEN ENERGIZED.
 - ALL FIELD WIRING MUST BE IN ACCORDANCE WITH THE NATIONAL ELECTRICAL CODE, STATE, AND LOCAL REQUIREMENTS. OTHER COUNTRIES APPLICABLE NATIONAL AND/OR LOCAL REQUIREMENTS SHALL APPLY. FIELD CONDUCTORS SHALL HAVE INSULATION RATING NOT LESS THAN 600V COPPER CONDUCTORS ONLY.
5. CONNECTIONS ARE INTENDED FOR CLASS 2 ONLY.
6. ALL AVAILABLE END DEVICES SHOWN. SEE UNIT CONFIGURATION FOR END DEVICES ON UNIT.
8. USE INSET A WHEN UNIT HAS THREE SUPPLY FANS.
9. USE INSET B WHEN R32 BEEN USED.

| AREA | DEVICE PREFIX LOCATION CODE | LOCATION |
|------|-----------------------------|---------------------------|
| 1 | | MAIN CONTROL PANEL |
| 2 | | SUPPLY FAN&COIL SECTION |
| 3 | | ELECTRIC HEAT CONTROL BOX |
| 4 | | FILTER SECTION |
| 5 | | MIXING BOX SECTION |
| 6 | | COIL ACCESS SECTION |
| 7 | | EXTERNAL PIPING |
| 8 | | FIELD INSTALLED DEVICE |
| 9 | | VFD CONTROL PANEL |

| DEVICE | DESCRIPTION |
|--------|-----------------------------------|
| 1W1 | ADAPTER BOARD |
| 2M1 | SUPPLY FAN 1 |
| 2M2 | SUPPLY FAN 2 |
| 2M3 | SUPPLY FAN 3 |
| 2R1 | MIXED AIR SENSOR |
| 2R2 | DISCHARGE AIR SENSOR |
| 2S1 | LOW LIMIT SWITCH |
| 2S2 | CONDENSATE OVERFLOW SWITCH |
| 2S3 | FAN STATUS SWITCH |
| 2S4 | FILTER STATUS SWITCH |
| 2S5 | LEAK DETECTION SENSOR (R454B,R32) |
| 5M1 | DAMPER ACTUATOR |

CAUTION
 USE COPPER CONDUCTORS ONLY!
 UNIT TERMINALS ARE NOT DESIGNED TO ACCEPT OTHER TYPES OF CONDUCTORS.
 FAILURE TO DO SO MAY CAUSE DAMAGE TO THE EQUIPMENT.

ATTENTION
 N'UTILISER QUE DES CONDUCTEURS EN CUIVRE!
 LES BORNES DE L'UNITÉ NE SONT PAS CONÇUES POUR RECEVOIR D'AUTRES TYPES DE CONDUCTEURS.
 L'UTILISATION DE TOUT AUTRE CONDUCTEUR PEUT ENDOMMAGER L'ÉQUIPEMENT.

PRECAUCIÓN
 ¡UTILICE ÚNICAMENTE CONDUCTORES DE COBRE!
 LAS TERMINALES DE LA UNIDAD NO ESTÁN DISERDAS PARA ACEPTAR OTROS TIPOS DE CONDUCTORES.
 SI NO LO HACE, PUEDE OCASIONAR DAÑO AL EQUIPO.

WARNING
 HAZARDOUS VOLTAGE!
 DISCONNECT ALL ELECTRIC POWER INCLUDING REMOTE DISCONNECTS AND FOLLOW LOCK OUT AND TAG PROCEDURES BEFORE SERVICING. INSURE THAT ALL MOTOR CAPACITORS HAVE DISCHARGED STORED VOLTAGE. UNITS WITH VARIABLE SPEED DRIVE, REFER TO DRIVE INSTRUCTIONS FOR CAPACITOR DISCHARGE. FAILURE TO DO THE ABOVE BEFORE SERVICING COULD RESULT IN DEATH OR SERIOUS INJURY.

AVERTISSEMENT
 TENSION DANGEREUSE!
 COUPER TOUTES LES TENSIONS ET OUVRIER LES SECTIONNEURS A DISTANCE, PUIS SUIVRE LES PROCÉDURES DE VERROUILLAGE ET DES ÉTIQUETTES AVANT TOUTE INTERVENTION. VÉRIFIER QUE TOUTES LES CONDENSATEURS DES MOTEURS SONT DÉCHARGÉS. DANS LE CAS D'UNITÉS COMPORTANT DES ENTRAÎNEMENTS À VITESSE VARIABLE, SE REPORTER AUX INSTRUCTIONS DE L'ENTRAÎNEMENT POUR DÉCHARGER LES CONDENSATEURS.

ADVERTENCIA
 ¡VOLTAJE PELIGROSO!
 DESCONECTE TODA LA ENERGÍA ELÉCTRICA, INCLUIDO LOS SECCIONNEURS A DISTANCIA Y SIGA LOS PROCEDIMIENTOS DE CIERRE Y ETIQUETADO ANTES DE PROCEDER AL SERVICIO. ASEGURESE DE QUE TODOS LOS CAPACITORES DEL MOTOR HAYAN DESCARGADO EL VOLTAJE ALMACENADO. PARA LAS UNIDADES CON EJE DE DIRECCIÓN DE VELOCIDAD VARIABLE, CONSULTE LAS INSTRUCCIONES PARA LA DESCARGA DEL CONDENSADOR. EL NO REALIZAR LO ANTERIORMENTE INDICADO, PODRÁ OCASIONAR LA MUERTE O SERIAS LESIONES PERSONALES.

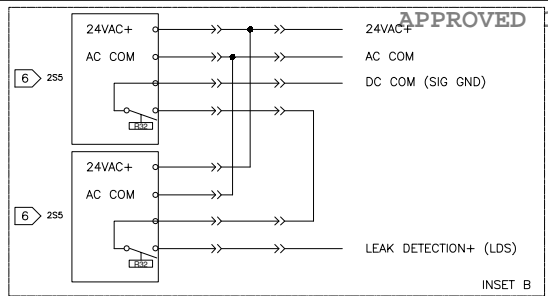

INSET B

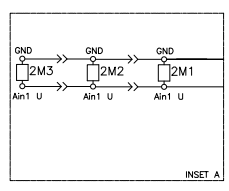
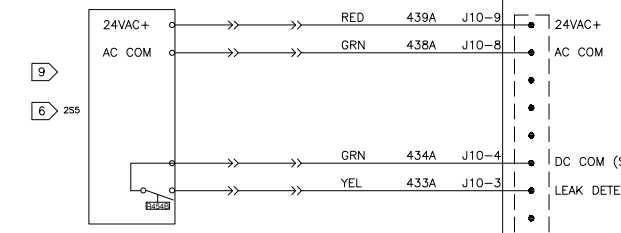

INSET A

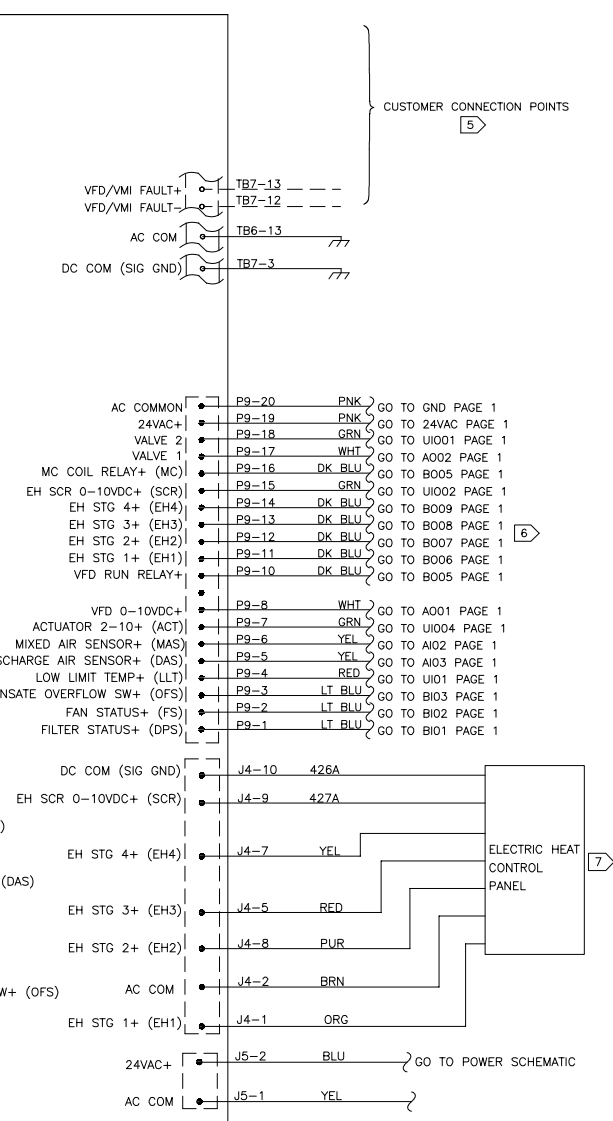
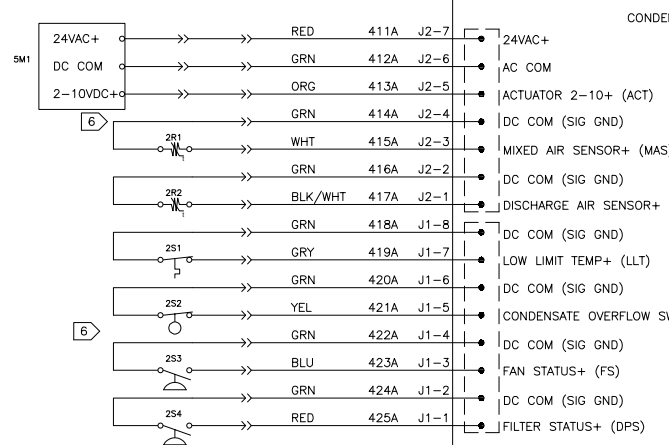

NOTES:

- UNLESS OTHERWISE NOTED ALL SWITCHES ARE SHOWN AT 25°C (77°F), AT ATMOSPHERIC PRESSURE, AT 50% RELATIVE HUMIDITY, WITH ALL UTILITIES TURNED OFF, AND AFTER A NORMAL SHUTDOWN HAS OCCURRED.
- DASHED LINES INDICATE RECOMMENDED FIELD WIRING BY OTHERS. DASHED LINES ENCLOSURES AND/OR DASHED DEVICE OUTLINES INDICATE COMPONENTS PROVIDED BY THE FIELD. PHANTOM LINES INDICATE CONTROL OPTION. PHANTOM LINES ENCLOSURES INDICATE ALTERNATE CIRCUITRY OR AVAILABLE SALES OPTIONS. SOLID LINES INDICATE WIRING BY TRANE.
- AN UNDERLINED NUMBER INDICATES A NORMALLY CLOSED CONTACT. AN OPEN ARROWHEAD BELOW THE LINE NUMBER POINTING UPWARD INDICATES A TIMED CONTACT WHICH BEGINS TIMING WHEN ENERGIZED.
- ALL FIELD WIRING MUST BE IN ACCORDANCE WITH THE NATIONAL ELECTRICAL CODE, STATE, AND LOCAL REQUIREMENTS. OTHER COUNTRIES APPLICABLE NATIONAL AND/OR LOCAL REQUIREMENTS SHALL APPLY. FIELD CONDUCTORS SHALL HAVE INSULATION RATING NOT LESS THAN 600V COPPER CONDUCTORS ONLY.

- CONNECTIONS ARE INTENDED FOR CLASS 2 ONLY.
- ALL AVAILABLE END DEVICES SHOWN. SEE UNIT CONFIGURATION FOR END DEVICES ON UNIT.
- ALL AVAILABLE ELECTRIC HEAT STAGES OR SCR SHOWN, SEE UNIT CONFIGURATION FOR ELECTRIC HEAT STAGES OR SCR ON UNIT.
- USE INSET A WHEN UNIT HAS THREE FANS.
- USE INSET B WHEN R32 BEEN USED.

| AREA | DEVICE PREFIX | LOCATION CODE | LOCATION |
|------|---------------|---------------|---------------------------|
| 1 | | | MAIN CONTROL PANEL |
| 2 | | | SUPPLY FAN&COIL SECTION |
| 3 | | | ELECTRIC HEAT CONTROL BOX |
| 4 | | | FILTER SECTION |
| 5 | | | MIXING BOX SECTION |
| 6 | | | COIL ACCESS SECTION |
| 7 | | | EXTERNAL PIPING |
| 8 | | | FIELD INSTALLED DEVICE |
| 9 | | | VFD CONTROL PANEL |

| DEVICE | DESCRIPTION |
|--------|-----------------------------------|
| 1W1 | ADAPTER BOARD |
| 2M1 | SUPPLY FAN 1 |
| 2M2 | SUPPLY FAN 2 |
| 2M3 | SUPPLY FAN 3 |
| 2R1 | MIXED AIR SENSOR |
| 2R2 | DISCHARGE AIR SENSOR |
| 2S1 | LOW LIMIT SWITCH |
| 2S2 | CONDENSATE OVERFLOW SWITCH |
| 2S3 | FAN STATUS SWITCH |
| 2S4 | FILTER STATUS SWITCH |
| 2S5 | LEAK DETECTION SENSOR (R454B,R32) |
| 5M1 | DAMPER ACTUATOR |

CAUTION
 USE COPPER CONDUCTORS ONLY!
 UNIT TERMINALS ARE NOT DESIGNED TO ACCEPT OTHER TYPES OF CONDUCTORS.
 FAILURE TO DO SO MAY CAUSE DAMAGE TO THE EQUIPMENT.

ATTENTION
 N'UTILISER QUE DES CONDUCTEURS EN CUIVRE!
 LES BORNES DE L'UNITÉ NE SONT PAS CONÇUES POUR RECEVOIR D'AUTRES TYPES DE CONDUCTEURS.
 L'UTILISATION DE TOUT AUTRE CONDUCTEUR PEUT ENDOMMAGER L'ÉQUIPEMENT.

PRECAUCIÓN
 ¡UTILICE ÚNICAMENTE CONDUCTORES DE COBRE!
 LAS TERMINALES DE LA UNIDAD NO ESTÁN DISEÑADAS PARA ACEPTAR OTROS TIPOS DE CONDUCTORES.
 SI NO LO HACE, PUEDE OCASIONAR DAÑO AL EQUIPO.

WARNING
 HAZARDOUS VOLTAGE!
 DISCONNECT ALL ELECTRIC POWER INCLUDING REMOTE DISCONNECTS AND FOLLOW LOCK OUT AND TAG PROCEDURES BEFORE SERVICING. INSURE THAT ALL MOTOR CAPACITORS HAVE DISCHARGED STORED VOLTAGE WITH VARIABLE SPEED DRIVE. REFER TO DRIVE INSTRUCTIONS FOR CAPACITOR DISCHARGE. FAILURE TO DO THE ABOVE BEFORE SERVICING COULD RESULT IN DEATH OR SERIOUS INJURY.

AVERTISSEMENT
 TENSION DANGEREUSE!
 COUPER TOUTES LES TENSIONS ET OUVRIER LES SECTIONNEURS A DISTANCE, PUIS SUIVRE LES PROCEDURES DE VERROUILLAGE ET DES ÉTIQUETTES AVANT TOUTE INTERVENTION. VÉRIFIER QUE TOUTS LES CONDENSATEURS DES MOTEURS SONT DÉCHARGÉS. DANS LE CAS D'UNITÉS COMPORTANT DES ENTRAÎNEMENTS À VITESSE VARIABLE, SE REPORTER AUX INSTRUCTIONS DE L'ENTRAÎNEMENT POUR DÉCHARGER LES CONDENSATEURS.

ADVERTENCIA
 ¡VOLTAJE PELIGROSO!
 DESCONECTE TODA LA ENERGÍA ELÉCTRICA, INCLUIDOS LOS SECCIONNEURS REMOTOS Y SIGA LOS PROCEDIMIENTOS DE CIERRE Y ETIQUETADO ANTES DE PROCEDER AL SERVICIO. ASEGURESE DE QUE TODOS LOS CAPACITORES DEL MOTOR HAYAN DESCARGADO EL VOLTAJE ALMACENADO. PARA LAS UNIDADES CON EJE DE DIRECCIÓN DE VELOCIDAD VARIABLE, CONSULTE LAS INSTRUCCIONES PARA LA DESCARGA DEL CONDENSADOR. EL NO REALIZAR LO ANTERIORMENTE INDICADO, PODRÁ OCASIONAR LA MUERTE O SERIAS LESIONES PERSONALES.