

SEE NAMEPLATE FOR VOLTAGE

SINGLE PHASE

SELECTIONS:
VOLTAGES ARE 115V/60HZ, 208V/60HZ, 230V/60HZ,
277V/60HZ, 220V/50HZ, 240V/50HZ

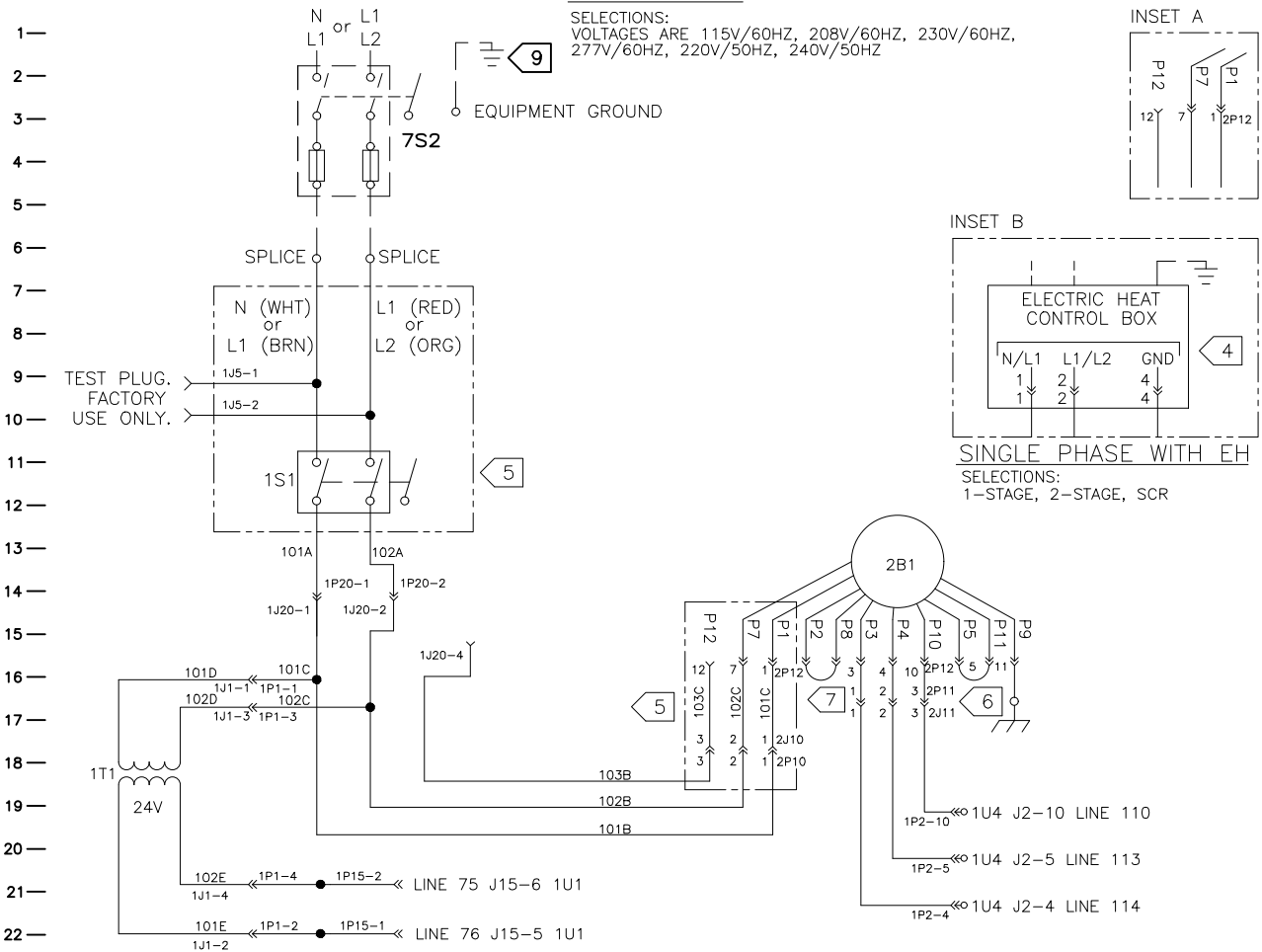

INSET A

INSET B

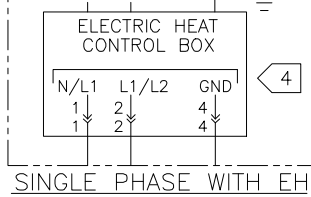

SINGLE PHASE WITH EH
SELECTIONS:
1-STAGE, 2-STAGE, SCR

HAZARDOUS VOLTAGE!

DISCONNECT ALL ELECTRIC POWER INCLUDING REMOTE DISCONNECTS AND FOLLOW LOCK OUT AND TAG PROCEDURES BEFORE SERVICING. INSURE THAT ALL MOTOR CAPACITORS HAVE DISCHARGED STORED VOLTAGE. UNITS WITH VARIABLE SPEED DRIVE, REFER TO DRIVE INSTRUCTIONS FOR CAPACITOR DISCHARGE.

FAILURE TO DO THE ABOVE BEFORE SERVICING COULD RESULT IN DEATH OR SERIOUS INJURY.

AVERTISSEMENT TENSION DANGEREUSE!

COUPER TOUTES LES TENSIONS ET OUVRIR LES SECTIONNEURS A DISTANCE, PUIS SUIVRE LES PROCEDURES DE VERROUILLAGE ET DES ETIQUETTES AVANT TOUTE INTERVENTION. VERIFIER QUE TOUS LES CONDENSATEURS DES MOTEURS SONT DECHARGES, DANS LE CAS D'UNITES COMPORTANT DES ENTRAINEMENTS A VITESSE VARIABLE, SE REPORTER AUX INSTRUCTIONS DE L'ENTRAINEMENT POUR DECHARGER LES CONDENSATEURS.

NE PAS RESPECTER CES MESURES DE PRECAUTION PEUT ENTRAINER DES BLESSURES GRAVES POUVANT ETRE MORTELLES.

ADVERTENCIA

¡VOLTAJE PELIGROSO!
DESCONECTE TODA LA ENERGIA ELECTRICA, INCLUIDO LAS DESCONECIONES REMOTAS Y SIGA LOS PROCEDIMIENTOS DE CIERRE Y ETIQUETADO ANTES DE PROCEDER AL SERVICIO. ASEGURESE DE QUE TODOS LOS CAPACITORES DEL MOTOR HAYAN DESCARGADO EL VOLTAJE ALMACENADO. PARA LAS UNIDADES CON EJE DE DIRECCION DE VELOCIDAD VARIABLE, CONSULTE LAS INSTRUCCIONES PARA LA DESCARGA DEL CONDENSADOR.

EL NO REALIZAR LO ANTERIORMENTE INDICADO, PODRIA OCASIONAR LA MUERTE O SERIAS LESIONES PERSONALES.

NOTICE

USE COPPER CONDUCTORS ONLY!
UNIT TERMINALS ARE NOT DESIGNED TO ACCEPT OTHER TYPES OF CONDUCTORS.
FAILURE TO DO THE ABOVE COULD RESULT IN EQUIPMENT DAMAGE.

AVIS

N'UTILISER QUE DES CONDUCTEURS EN CUIVRE!
LES BORNES DE L'UNITE NE SONT PAS CONÇUES POUR RECEVOIR D'AUTRES TYPES DE CONDUCTEURS.
FAIRE DÉFAUT À LA PROCÉDURE CI-DESSUS PEUT ENTRAINER DES DOMMAGES À L'ÉQUIPEMENT.

AVISO

¡UTILICE ÚNICAMENTE CONDUCTORES DE COBRE!
LAS TERMINALES DE LA UNIDAD NO ESTÁN DISEÑADAS PARA ACEPTAR OTROS TIPOS DE CONDUCTORES.
NO SEGUIR LAS INSTRUCCIONES ANTERIORES PUEDE PROVOCAR DAÑOS EN EL EQUIPO.

LEGEND		
DEVICE DESIGNATION	DESCRIPTION	LINE NUMBER
SINGLE PHASE		
7S2	FUSED DISCONNECT SWITCH	3
1S1	MANUAL DISCONNECT SWITCH	12
1T1	TRANSFORMER	18
2B1	FAN MOTOR	14
THREE PHASE (0.5, 1, 2.3 HP)		
7S2	FUSED DISCONNECT SWITCH	27
1S1	MANUAL DISCONNECT SWITCH	37
1T1	TRANSFORMER	44
2B1	FAN MOTOR	39
THREE PHASE (1.5, 3.0, 3.5, 5.0 HP)		
7S2	FUSED DISCONNECT SWITCH	54
1S1	MANUAL DISCONNECT SWITCH	63
1T1	TRANSFORMER	70
2B1	FAN MOTOR	58
2U1	MOTOR DRIVER	67

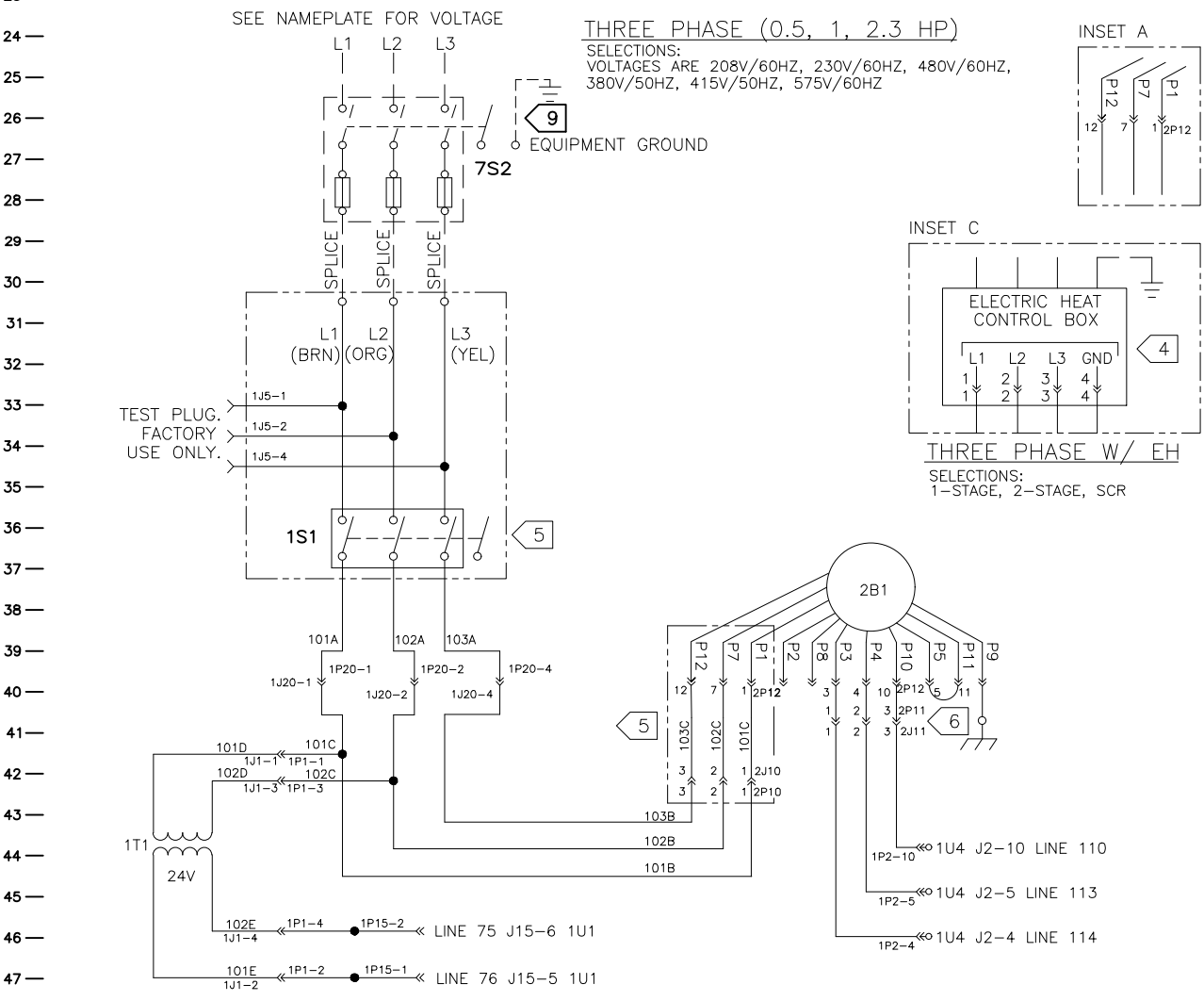

INSET A

INSET C

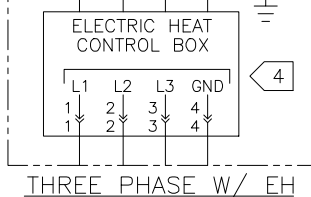

THREE PHASE W/ EH
SELECTIONS:
1-STAGE, 2-STAGE, SCR

DEVICE PREFIX LOCATION CODE	
AREA	LOCATION
1	MAIN CONTROL PANEL
2	SUPPLY FAN AND COIL SECTION
3	
4	MIXING BOX
5	EXTERNAL PIPING
6	ELECTRIC HEAT CONTROL BOX
7	FIELD INSTALLED DEVICE

THREE PHASE W/ DRIVER (1.5, 3.0, 3.5, 5.0 HP)

SELECTIONS:
VOLTAGES ARE 208V/60HZ, 230V/60HZ, 480V/60HZ,
380V/50HZ, 415V/50HZ, 575V/60HZ

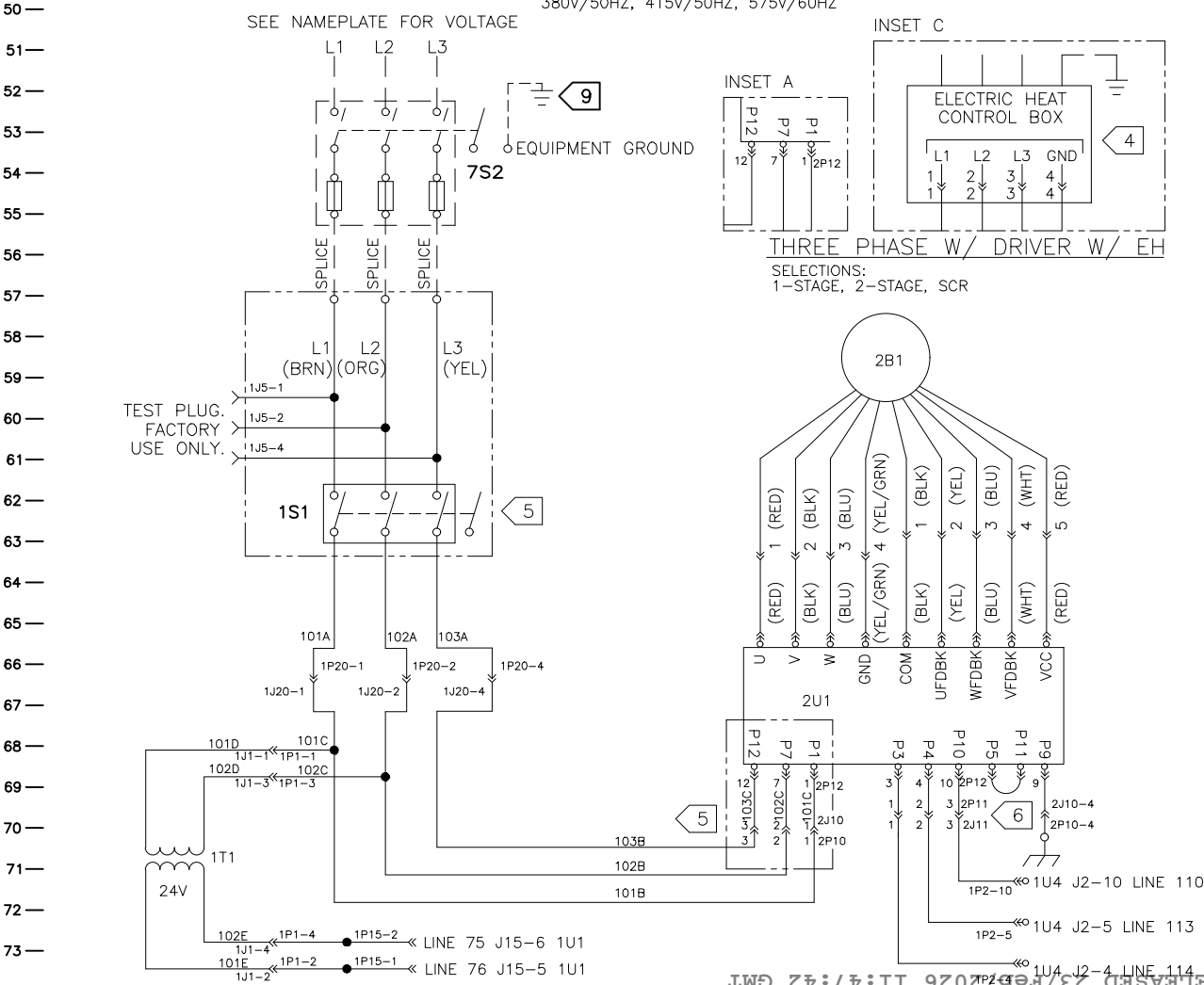

INSET A

INSET C

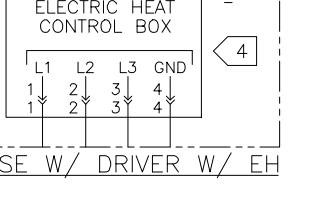

THREE PHASE W/ DRIVER W/ EH
SELECTIONS:
1-STAGE, 2-STAGE, SCR

NOTES:

- UNLESS OTHERWISE NOTED, ALL SWITCHES ARE SHOWN AT 25° C (77° F), AT ATMOSPHERIC PRESSURE, AT 50% RELATIVE HUMIDITY, WITH ALL UTILITIES TURNED OFF, AND AFTER A NORMAL SHUTDOWN HAS OCCURRED.
- DASHED LINES INDICATE RECOMMENDED FIELD WIRING BY OTHERS. DASHED LINE ENCLOSURES AND/OR DASHED DEVICE OUTLINES INDICATE COMPONENTS PROVIDED BY THE FIELD. PHANTOM LINED ENCLOSURES INDICATE ALTERNATE CIRCUITRY OR AVAILABLE SALES OPTIONS. SOLID LINES INDICATE WIRING BY TRANE CO.
- ALL FIELD WIRING MUST BE IN ACCORDANCE WITH THE NATIONAL ELECTRIC CODE (NEC), STATE AND LOCAL REQUIREMENTS.
- ELECTRIC HEAT SCHEMATIC IS LOCATED IN THE ELECTRIC HEAT CONTROL BOX PANEL.
- WIRING SHOWN IS FOR NO ELECTRIC HEAT. FOR ELECTRIC HEAT SINGLE PHASE SEE INSET A&B. FOR ELECTRIC HEAT THREE PHASE SEE INSET A&C.
- CW JUMPER IS PRESENT FROM PIN P5 TO P11 ON UNITS WITH CW MOTOR ROTATION AS VIEWED FROM SHAFT END.
- MOTOR VOLTAGE CONFIGURATION P2-P8 JUMPERED FOR 115V OPERATION ONLY.
- USE COPPER CONDUCTORS ONLY.
- ATTACH EQUIPMENT GROUND.

DATE	28-SEP-2025
REVISION DATE	
DRAWN BY	
CHECKED BY	
SCALE	1:1
SIMILAR TO	
TRANE	50262935
SCHEMATIC DIAGRAM	
UC-400-B, SYMBD 400-B	
POWER	
BLOWER COIL - BCKE	