



User Guide

Trane Communicating Thermostats for Heat Pump Control

BACnet MS/TP version X13511542010



SAFETY WARNING

Only qualified personnel should install and service the equipment. The installation, starting up, and servicing of heating, ventilating, and air-conditioning equipment can be hazardous and requires specific knowledge and training. Improperly installed, adjusted or altered equipment by an unqualified person could result in death or serious injury. When working on the equipment, observe all precautions in the literature and on the tags, stickers, and labels that are attached to the equipment.



Introduction

Warnings, Cautions, and Notices

Safety advisories appear throughout this manual as required. Your personal safety and the proper operation of this machine depend upon the strict observance of these precautions.

The three types of advisories are defined as follows:

⚠ WARNING Indicates a potentially hazardous situation which, if not avoided, could result in death or serious injury.

⚠ CAUTION Indicates a potentially hazardous situation which, if not avoided, could result in minor or moderate injury. It could also be used to alert against unsafe practices.

NOTICE Indicates a situation that could result in equipment or property-damage only accidents.

Important Environmental Concerns

Scientific research has shown that certain man-made chemicals can affect the earth's naturally occurring stratospheric ozone layer when released to the atmosphere. In particular, several of the identified chemicals that may affect the ozone layer are refrigerants that contain Chlorine, Fluorine and Carbon (CFCs) and those containing Hydrogen, Chlorine, Fluorine and Carbon (HCFCs). Not all refrigerants containing these compounds have the same potential impact to the environment. Trane advocates the responsible handling of all refrigerants-including industry replacements for CFCs and HCFCs such as saturated or unsaturated HFCs and HCFCs.

Important Responsible Refrigerant Practices

Trane believes that responsible refrigerant practices are important to the environment, our customers, and the air conditioning industry. All technicians who handle refrigerants must be certified according to local rules. For the USA, the Federal Clean Air Act (Section 608) sets forth the requirements for handling, reclaiming, recovering and recycling of certain refrigerants and the equipment that is used in these service procedures. In addition, some states or municipalities may have additional requirements that must also be adhered to for responsible management of refrigerants. Know the applicable laws and follow them.

⚠ WARNING

Proper Field Wiring and Grounding Required!

Failure to follow code could result in death or serious injury. All field wiring MUST be performed by qualified personnel. Improperly installed and grounded field wiring poses FIRE and ELECTROCUTION hazards. To avoid these hazards, you MUST follow requirements for field wiring installation and grounding as described in NEC and your local/state electrical codes. Failure to follow code could result in death or serious injury.

⚠ WARNING**Personal Protective Equipment (PPE) Required!**

Failure to wear proper PPE for the job being undertaken could result in death or serious injury. Technicians, in order to protect themselves from potential electrical, mechanical, and chemical hazards, **MUST** follow precautions in this manual and on the tags, stickers, and labels, as well as the instructions below:

- Before installing/servicing this unit, technicians **MUST** put on all PPE required for the work being undertaken (Examples; cut resistant gloves/sleeves, butyl gloves, safety glasses, hard hat/bump cap, fall protection, electrical PPE and arc flash clothing). **ALWAYS** refer to appropriate Safety Data Sheets (SDS) and OSHA guidelines for proper PPE.
- When working with or around hazardous chemicals, **ALWAYS** refer to the appropriate SDS and OSHA/GHS (Global Harmonized System of Classification and Labeling of Chemicals) guidelines for information on allowable personal exposure levels, proper respiratory protection and handling instructions.
- If there is a risk of energized electrical contact, arc, or flash, technicians **MUST** put on all PPE in accordance with OSHA, NFPA 70E, or other country-specific requirements for arc flash protection, **PRIOR** to servicing the unit. **NEVER PERFORM ANY SWITCHING, DISCONNECTING, OR VOLTAGE TESTING WITHOUT PROPER ELECTRICAL PPE AND ARC FLASH CLOTHING. ENSURE ELECTRICAL METERS AND EQUIPMENT ARE PROPERLY RATED FOR INTENDED VOLTAGE.**

⚠ WARNING**Follow EHS Policies!**

Failure to follow instructions below could result in death or serious injury.

- All Trane personnel must follow the company's Environmental, Health and Safety (EHS) policies when performing work such as hot work, electrical, fall protection, lockout/tagout, refrigerant handling, etc. Where local regulations are more stringent than these policies, those regulations supersede these policies.
- Non-Trane personnel should always follow local regulations.

Copyright

This document and the information in it are the property of Trane, and may not be used or reproduced in whole or in part without written permission. Trane reserves the right to revise this publication at any time, and to make changes to its content without obligation to notify any person of such revision or change.

Trademarks

All trademarks referenced in this document are the trademarks of their respective owners.

Revision History

Miscellaneous edits.



Table of Contents

Product Overview	5
Features and Benefits	5
Theory of Operation	5
Features Overview	6
Heat Pump Model Specific Features	7
Installation	8
Before Installation	8
Thermostat Location	8
Installation Procedure	8
Screw Terminal Arrangement	11
Detailed Wiring Diagram Models	12
User Menu Flow Chart	13
Status Display Instructions	14
Sequence of Auto-Scroll Status Display	14
User Programming Instructions Menu	16
The User Menu Sequence	17
Detailed Description of Menu Settings	17
Temporary Setpoint Changes	18
Installer Configuration Parameter Menu	20
Troubleshooting Guide (All Models)	25
Troubleshooting Guide	27
Specifications	28
Drawings and Dimensions	29



Product Overview

The Trane Communicating Heat Pump Thermostat is specifically designed for control of self-contained heating/cooling heat pump units. The product features an intuitive, menu-driven, backlit LCD display, which walks users through the programming steps, making the process extremely simple. Accurate temperature control is achieved due to the product's PI time proportional control algorithm, which virtually eliminates temperature offset associated with traditional, differential-based thermostats.

Two digital inputs can be set by the installer to monitor filter status, activate a remote temporary occupancy switch, and/or used as a general purpose service indicator.

Three remote sensor inputs are provided: Remote room or return air temperature, outdoor air temperature, and supply air temperature for monitoring purposes.

An SPST auxiliary switch output that operates with the occupancy can be used to control lighting or disable the economizer minimum fresh air function.

The thermostats are also compatible with the occupancy sensor cover accessories. Thermostats equipped with an occupancy sensor cover provide advanced active occupancy logic, which will automatically switch occupancy levels from Occupied to Unoccupied as required by local activity being present or not. This advanced occupancy functionality provides advantageous energy savings during occupied hours without sacrificing occupant comfort.

Features and Benefits

Features	Benefits
Advanced occupancy functions	Through the network or smart local occupancy sensing
Ready for occupancy sensor accessory cover	Fully integrated advanced occupancy functionality with a occupancy sensor accessory cover
Two extra digital inputs	Adds functionality
Smart fan operation	Saves energy during night mode
Unique configuration key with password protection	Minimizes parameter tampering
Lockable keypad	Tamper proof, no need for thermostat guards
Remote room and outdoor temperature sensor	Increase flexibility and functionality
Auxiliary output	Can be used for lighting and/or economizer override
Discharge air sensor input	Can be used to monitor unit efficiency

Theory of Operation

The Trane Communicating Thermostat uses a proprietary adaptive logic algorithm to control the space temperature. This algorithm controls the heating / air conditioning system to minimize overshoot while still providing comfort. It provides exceptional accuracy due to its unique PI time proportioning control algorithm, which virtually eliminates temperature offset associated with traditional, differential-based on/off thermostats.

Figure 1. On/off mechanical control vs pi electronic control

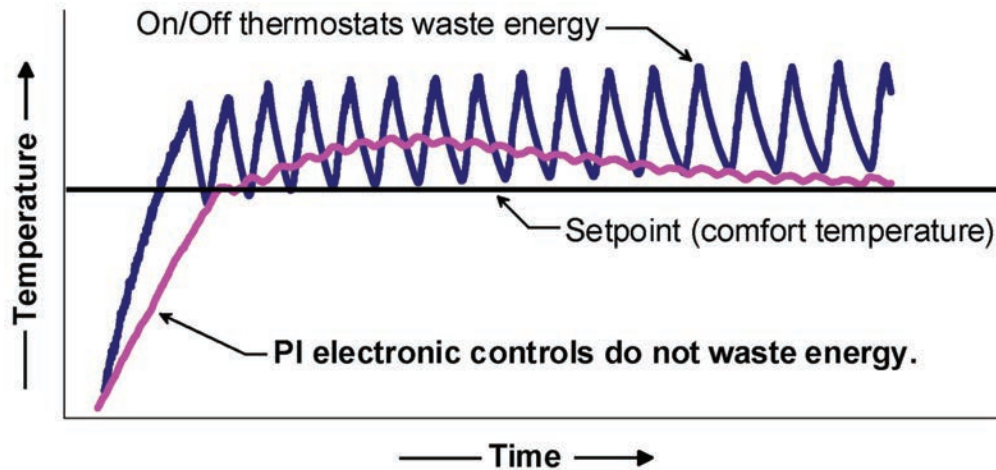

Features Overview

The Trane Communicating Thermostat includes the following features:

- Remote outdoor sensing capability for added flexibility
 - System mode lock out
 - Heat pump balance point settings
- Remote discharge air sensor input for monitoring purpose
 - System efficiency feedback
- Lockable keypads for tamper proofing (No need for thermostat guards)
- Automatic frost protection to prevent costly freeze damage
- Anti short cycle and minimum on/off run time protection. Reduces wear and maximizes life span of mechanical equipment
- Two programmable digital inputs for added flexibility. Each input can be programmed as the following:
 - **None:** No function will be associated with the input.
 - **Service:** A backlit flashing **Service** alarm will be displayed on the thermostat LCD screen when the input is energized. It can be tied in to the AC unit control card, which provides an alarm in case of malfunction.
 - **Filter:** A backlit flashing Filter alarm will be displayed on the thermostat LCD screen when the input is energized. It can be tied to a differential pressure switch that monitor filters.
 - **Rem NSB:** Remote NSB timer clock input. Will disable the internal scheduling of the thermostat. The scheduling will now be set as per the digital input. The menu part related to scheduling is disabled and no longer accessible. It provides low cost setback operation via occupancy sensor or from a dry contact.
 - **RemOVR:** Temporary occupancy contact. Disables all override menu function of the thermostat. The override function is now controlled by a manual remote momentarily closed contact. When configured in this mode, the input operates in a toggle mode.

With this function enabled it is now possible to toggle between unoccupied and occupied setpoints for the amount of time set by parameter (TOccTime) temporary occupancy time.

- **Fan lock:** Used in conjunction with a local air flow sensor connected to the input. Locks out the thermostat heating and cooling action and displays a local alarm if no air flow is detected 10 seconds after the fan (G terminal) is energized.
- Programmable smart fan operation saves energy during night mode
- Non volatile EEPROM memory prevents loss of parameters during power shortage
- Built in default profile set-up for easier start up and commissioning
- Configurable SPST output relay on programmable models for lighting, exhaust fan or fresh air control

Heat Pump Model Specific Features

The Trane Communicating Thermostat includes the following features:

- Selectable single or dual stage compressor stages
- High balance point:
Locks out auxiliary heating when outside air temperature is above this value
- Low balance point:
Locks out heat pump compressor operation when outside air temperature is below this value
- Comfort/economy mode:
In economy mode, heat pump use is maximized before turning on auxiliary heating
- Compressor/auxiliary interlock:
Adds flexibility by locking out heat pump operation during auxiliary heating to prevent high pressure trip when the coil is downstream of the auxiliary heat source



Installation

This section explains preliminary installation tasks, location considerations, and the installation procedure.

Before Installation

Complete the following steps:

1. Remove the security screw on the bottom of Terminal Equipment Controller cover.
2. Open unit by pulling on the bottom side of Terminal Equipment Controller (see the below figure).
3. Remove wiring terminals from sticker.

Figure 2. Opening unit



Thermostat Location

Install the thermostat

- On an inside wall only.
- Away from any direct heat source.
- Away from any air discharge grill.
- Away from direct sun radiation.

Nothing should restrict vertical air circulation to the Terminal Equipment Controller.

Installation Procedure

1. Swing open the Terminal Equipment Controller PCB to the left by pressing the PCB locking tabs ([Figure 3, p. 9](#)).
2. Pull out cables 6 inch out from the wall.
3. Wall surface must be flat and clean.
4. Insert cable in the central hole of the base.

5. Align the base and mark the location of the two mounting holes on the wall. Install proper side of base up.
6. Install anchors in the wall.
7. Insert screws in mounting holes on each side of the base (see the figure below).

Figure 3. Location of PCB retaining tabs

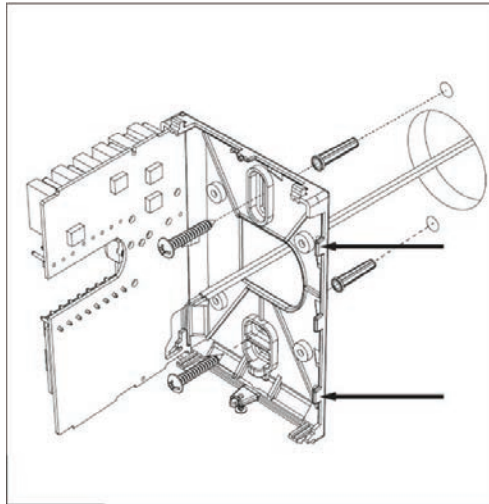

8. Gently swing back the circuit board on the base and push on it until the tabs lock it.
9. Strip each wire 1/4 inch from end.
10. Insert each wire according to wiring diagram.
11. Gently push excess wiring back into hole (see the figure below).
12. Re-install wiring terminals in their correct locations (see the figure below).
13. Re-install the cover (top side first) and gently push extra wire length back into the hole in the wall.
14. Install security screw.

Figure 4. Reinstall terminal blocks

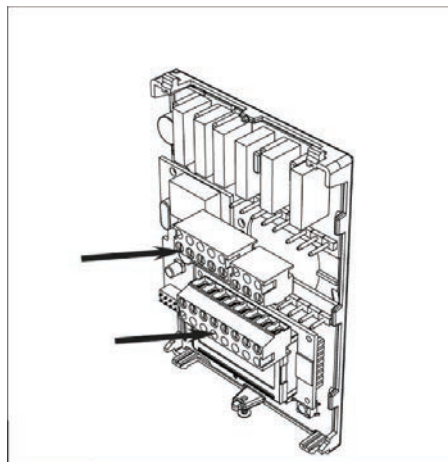

⚠ CAUTION**Take adequate precautions during installation!**

If replacing an existing Communicating RTU Thermostat, label the wires before removal of the thermostat.

Electronic controls are static sensitive devices. Discharge yourself properly before manipulating and installing the controller.

A short circuit or wrong wiring may permanently damage the Terminal Equipment Controller or the equipment.

⚠ CAUTION**Use proper safety measures to protect system!**

All Communicating RTU thermostats are for use as operating controls only and are not safety devices. These instruments have undergone rigorous tests and verifications prior to shipment to ensure proper and reliable operation in the field. Whenever a control failure could lead to personal injury and/or loss of property, it becomes the responsibility of the user / installer / electrical system designer to incorporate safety devices (such as relays, flow switch, thermal protections, etc.) and/or an alarm system to protect the entire system against such catastrophic failures. Tampering with the devices or misapplication of the device will void warranty.

Screw Terminal Arrangement

The screw terminals are arranged as follows.

Figure 5. Screw terminal diagram

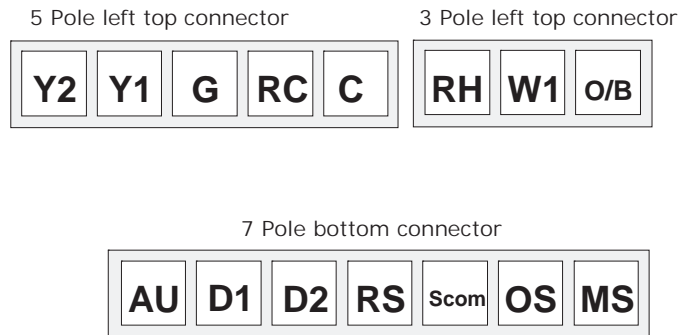

Observe the following wiring considerations and requirements:

- If the same power source is used for auxiliary heating stages, install jumper across RC and RH. Maximum current is 2.0 amps.
- If auxiliary output is used to toggle occupancy of the electronic control card inside the equipment, configure the relay parameter (Aux cont) to the N.O. setting. A second relay can be added for additional functionality of the occupancy output.
- Electromechanical contacts are to be used with the digital inputs. Electronic triacs cannot be used as a means of switching for the input. The switched leg to the input for the input to activate is terminal C (common).
- The transformer of the unit provides power to the thermostat and the additional loads that will be wired to the thermostat.

Detailed Wiring Diagram Models

Figure 6. Wiring diagram

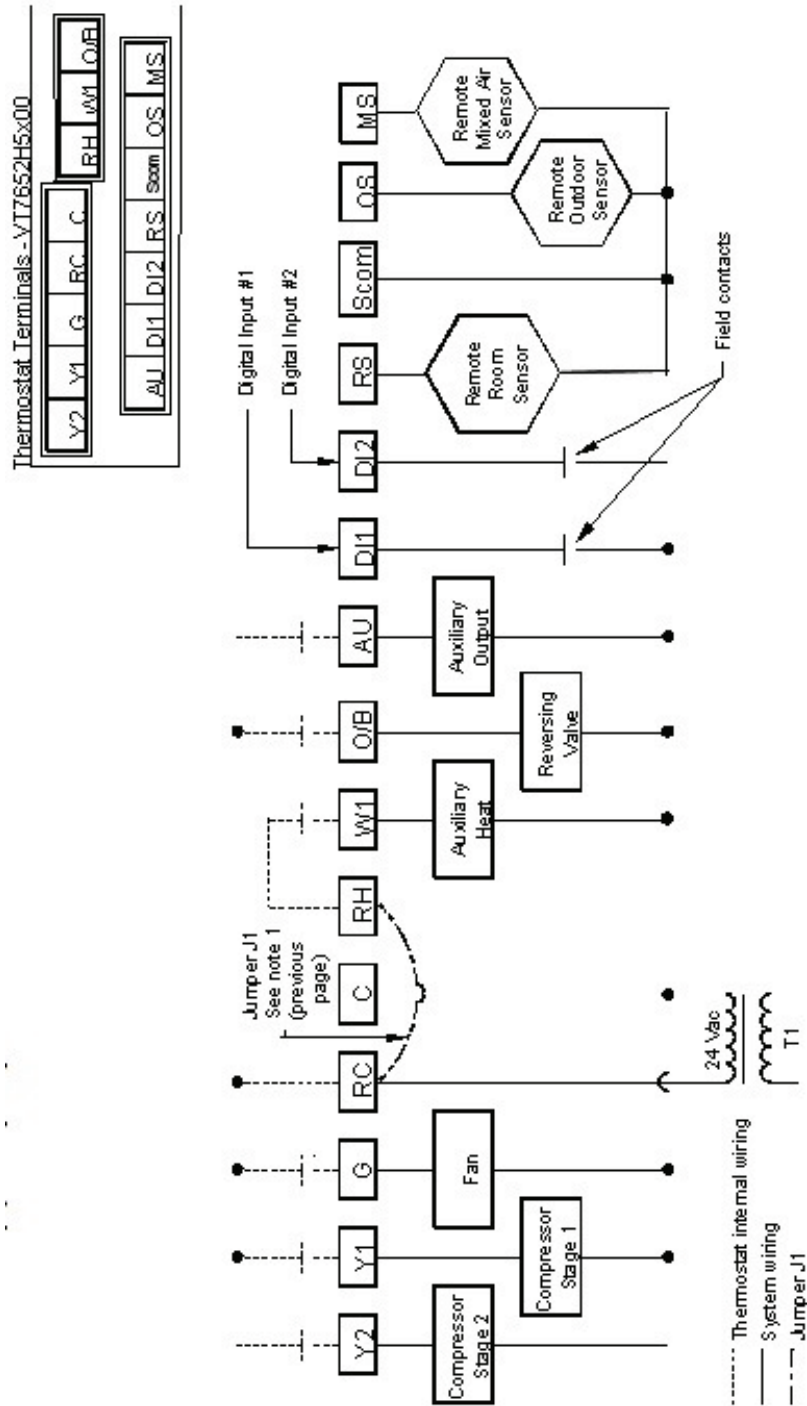

User Menu Flow Chart

The following flow diagram indicates the menu items in order of appearance.

Figure 7. User menu flow chart

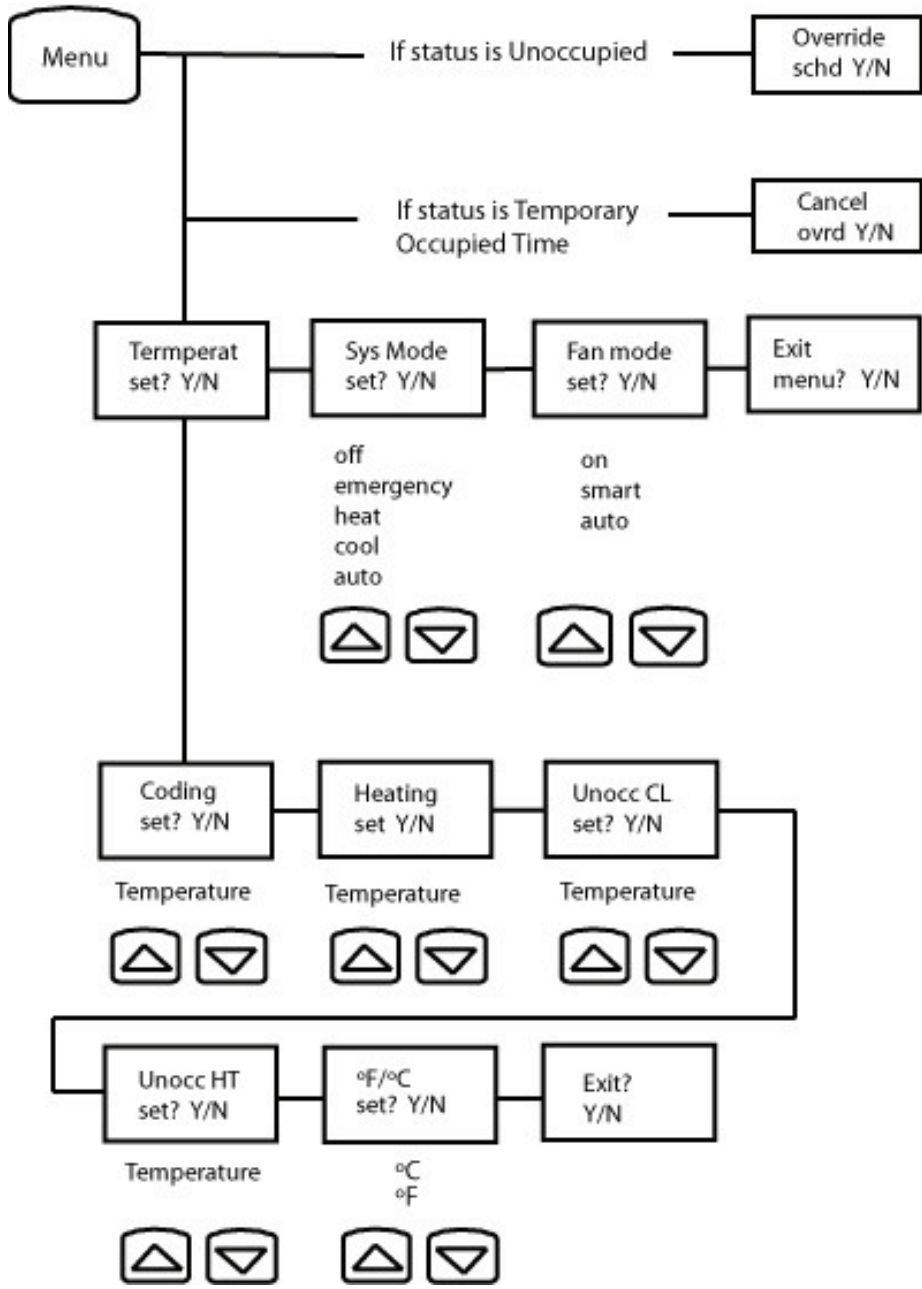



Status Display Instructions

The thermostat features a two-line, eight-character display. There is a low level back-light level that is always active and can only be seen at night. When left unattended, the thermostat has an auto scrolling display that shows the actual status of the system. Each item is scrolled one by one with the back lighting off. Pressing any key will cause the back light to come on.

Sequence of Auto-Scroll Status Display

Room Temperature	System Mode	Schedule Status	Outdoor Temperature	Alarms
Room Temp x.x°C or °F	Sys mode auto	Occupied	Outdoor x.x°C or °F	Service
	Sys mode off	Unoccup		Frost ON
	Sys mode heat	Override		SetClock
	Sys mode cool			Filter
	Sys mode emergenc			Fan lock

Manual scroll of each menu item is achieved by pressing the Yes (scroll) key repetitively. The last item viewed will be shown on the display for 30 seconds before returning to automatic scrolling. Temperature is automatically updated when scrolling is held.

The outdoor air temperature display is enabled only when an outdoor air temperature sensor is connected.

A maximum range status display of 50°C (122°F) indicates a shorted sensor. Associated functions, such as mode lockouts and economizer function are automatically disabled.

A minimum range status -40°C (-40°F) is not displayed and indicates a opened sensor or a sensor not connected. Associated functions, such as mode lockouts and economizer function are automatically disabled.

If alarms are detected, they are automatically displayed at the end of the status display scroll. During an alarm message display, the back lit screen lights up at the same time as the message and shuts off during the rest of the status display. Two alarms maximum can appear at any given time.

The priority for the alarms is as follows:

Frost ON	Indicates that the heating is energized by the low limit frost protection room temperature setpoint 5.6°C (42°F)
SetClock	Indicates that the clock needs to be reset. There has been a power failure which has lasted longer than 6 hours
Service	Indicates that there is a service alarm as per one of the programmable digital input (DI1 or DI2)
Filter	Indicates that the filters are dirty as per one of the programmable digital input (DI1 or DI2)
Fan lock	Indicates that the heating and cooling actions are locked out due to a defective fan operation

Three status LEDs on the thermostat cover are used to indicate the status of the fan, a call for heat, or a call for cooling.

LED Operation	Trane Heat Pump Models
Fan LED on	When G Fan terminal operates
Heating LED on	When Y1 and / or W1 terminal(s) operate in heating mode
Cooling LED on	When Y1 terminal operate in cooling mode

Figure 8. Heat pump models

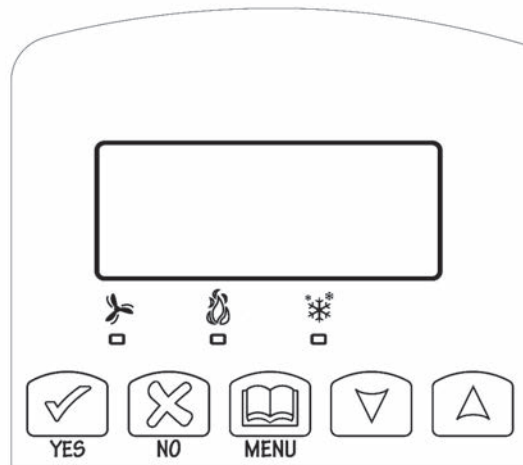



User Programming Instructions Menu

The Trane Communicating Thermostat features an intuitive, menu-driven, back-lit LCD display that walks users through the programming steps, making the programming process extremely simple. This menu is typically accessed by the user to set the parameters such as temperature and time events, system mode, fan mode, and so on.

It is possible to bring up the user menu at any time by depressing the MENU key. The status display automatically resumes after exiting the user-programming menu.





If the user pauses at any given time during programming, Auto Help text is displayed to help and guide the user through the usage and programming of the thermostat.

Example: Press yes key to change cooling temperature setpoint.

Use the up or down arrow to adjust cooling setpoint.

Each of the sections in the menu are accessed and programmed using five keys on the thermostat cover.

The priority for the alarms is as follows:

	The YES key is used to confirm a selection, to move onto the next menu item and to manually scroll through the displayed information.
	The NO key is used when you do not desire a parameter change, and to advance to the next menu item. It can also be used to toggle between heating and cooling setpoints.
	The MENU key is used to access the Main User Menu or exit the menu.
	The down arrow key is used to decrease temperature setpoint and to adjust the desired values when programming and configuring the thermostat.
	The up arrow key is used to increase temperature setpoint and to adjust the desired values when programming and configuring the thermostat.

When left unattended for 45 seconds, the display will resume automatic status display scrolling.

To turn on the back light, press any key on the front panel. The back lit display will turn off when the thermostat is left unattended for 45 seconds.



The User Menu Sequence

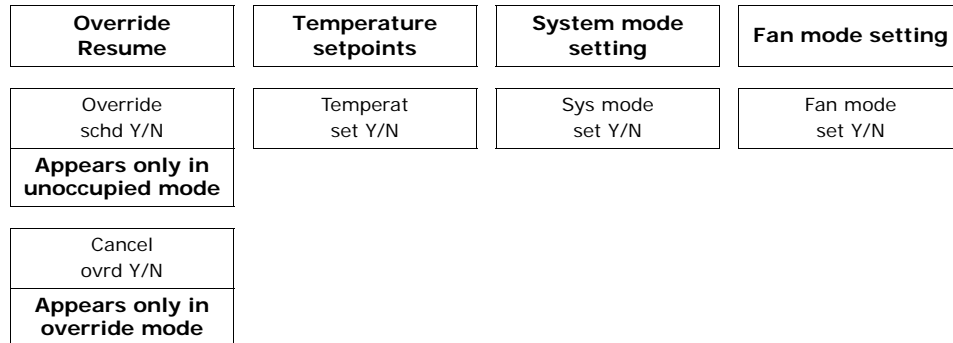

There is a default profile set in the thermostat from the factory. This enables the thermostat to operate as a non-programmable unit in day mode operation at start up.

Programmed default temperature setpoints:	Programmed default modes:
Occupied cooling setpoint = 75°F (24°C)	System mode = Auto
Occupied heating setpoint = 72°F (22°C)	Fan mode = Smart (for models with a communication module or programmable stand-alone models)
Unoccupied cooling setpoint = 82°F (28°C)	Fan mode = Auto (for non-programmable stand-alone models)
Unoccupied heating setpoint = 65°F (18°C)	
Fahrenheit scale	
Setpoint type = Permanent	

Detailed Description of Menu Settings

Override an unoccupied period

Override schd Y/N

This menu will appear only when the thermostat is in unoccupied mode. The unoccupied mode is enabled either by the internal timer scheduling or by a remote NSB contact via D11 or D12.

If D11 or D12 is configured to operate as a remote temporary override contact, this menu will be disabled.

Answering yes to this prompt will cause the thermostat to go into occupied mode for an amount of time equal to the parameter "TOcTime" (1 to 12 hours).

Resume regular scheduling

Cancel Ovrd Y/N

This menu does not appear in regular operation. It will appear only when the thermostat is in Unoccupied override mode.

Answering "Yes" to this question will cause the thermostat to resume the regular programmed setpoints scheduling.

Permanent setpoint changes

Temperat set Y/N

This menu permits the adjustment of all permanent temperature setpoints (occupied and unoccupied) as well as the desired temperature units (°F or °C). Permanent setpoints are written to RAM and EEPROM.

The User Menu Sequence

Cooling setpoint Occupied mode		Heating setpoint Occupied mode		Cooling setpoint Unoccupied mode	
Cooling set? Y/N	No next → Yes down ↓	Heating set? Y/N	No next → Yes down ↓	Unocc CL set? Y/N	No next → Yes down ↓
Use ▲▼ keys to set value, Yes key to confirm					
Cooling 70.0°F	Use ▲▼ To set value	Heating 68.0°F	Use ▲▼ To set value	Unocc CL 80.0°F	Use ▲▼ To set value

Heating setpoint Unoccupied mode		°F or °C display setting	
Unocc HT set? Y/N	No next → Yes down ↓	°F or °C set? Y/N	No next → Yes down ↓
Use ▲▼ keys to set value, Yes key to confirm			
Unocc HT 60.0°F	Use ▲▼ To set value	Units °F	Use ▲▼ To set value

Temporary Setpoint Changes

(▲) (▼)	Temporary setpoints can be modified through the Up arrow key and the Down arrow keys.
(Heating or Cooling)	You are prompted with the present mode of the thermostat and its setpoint.
(▲)	The Up arrow key will increment the setpoint by 0.5 degree (°F or °C).
(▼)	The Down arrow key will decrement the setpoint by 0.5 degree (°F or °C).
	Press the Yes key to accept the new setpoint.

Notes:

- Local changes to the heating or cooling setpoints made directly using the up or down arrow are temporary.
- Local changes remain effective for the duration specified by ToccTime.
- Setpoints revert back to their default value after internal timer ToccTime expires.
- If a permanent change to the setpoints is required, use the **Temperat set?** menu.

System mode setting This menu is accessed to set system mode operation
Use ▲▼ keys to set value, Yes key to confirm.

Sys mode Y/N

Sys mode auto	Automatic mode Automatic changeover mode between heating and cooling operation
Sys mode cooling	Cooling mode Cooling operation mode only
Sys mode heating	Heating mode Heating operation mode only
Sys mode emergency	Emergency heat mode (heat pump models only) Forced auxiliary heat operation mode only
Sys mode off	Off mode Normal cooling or heating operation disabled If enabled in installer parameters, only the automatic heating frost protection at 50°F (10°C) is enabled

The User Menu Sequence

Fan mode setting This section of the menu is permits the setting of the fan mode operation. Use ▲▼ keys to set value, Yes key to confirm.

Sys mode Y/N

Fan mode On	On fan mode Fan is on continuously, even when system mode is OFF.
Fan mode Auto	Automatic fan mode Fan cycles on a call for heating or cooling for both occupied and unoccupied periods.
Fan mode Smart	Smart fan mode During occupied periods, fan is on continuously. In unoccupied mode, fan cycles on a call for heating or cooling. This selection is available on all models with a communication module, on all stand-alone programmable models or if D11 or D12 is set to RemNSB on stand-alone non-programmable models.



Installer Configuration Parameter Menu

You can perform configuration through the network or locally at the thermostat.

1. Press and hold the middle button **Menu** for 8 seconds to enter configuration.
2. If a password lockout is active, "Password" is prompted. Enter the password value using the up and down arrows and press **Yes** to gain access to all configuration properties of the thermostat.

(A wrong password entered prevents local access to the configuration menu.)

3. Once in the configuration menu, press the **No** button repetitively to scroll between all the available parameters.
4. When the desired parameter is displayed, press **Yes** to adjust it to the desired value using up and down arrows. Once set, press **Yes** to scroll to the next parameter.

Configuration parameters	Significance Default value	Adjustments
Pswrd	Configuration parameters menu access password Default value = 0 (no password prompted)	This parameter sets a protective access password to prevent unauthorized access to the configuration menu parameters. A default value of "0" will not prompt a password or lock the access to the configuration menu. Range is: 0 to 1000
Com addr	Thermostat networking address Default value = 254 Range is: 0 to 254	Conditional parameter to BACnet MS/TP models (VT76xxX5x00B) This parameter will only appear when a BACnet or wireless network adapter is present. If the BACnet adapter has been removed or replaced with an Echelon adapter, the parameter will not be used or displayed. For BACnet MS/TP models valid range to use is from 1 to 127. Default value of 254 disables BACnet communication for the thermostat.
DI 1	Digital input no. 1 configuration Open contact input = function not energized Closed contact input = function energized Default value = None	None , No function will be associated with the input. Rem NSB , remote NSB timer clock input. Will disable the internal scheduling of the thermostat. The scheduling will now be set as per the digital input. The time is still displayed as information, but the menu part related to scheduling is disabled and no longer accessible. Open contact = occupied setpoints Closed contacts = unoccupied setpoints RemOVR Temporary override remote contact. Disables all override menu function of the thermostat. The override function is now controlled by a manual remote momentarily closed contact. When configured in this mode, the input operates in a toggle mode. With this function enabled it is now possible to toggle between unoccupied and occupied setpoints for the amount of time set by parameter (TOccTime) temporary occupancy time. When Override is enabled, an Override status message will be displayed. Filter , a back-lit flashing Filter alarm will be displayed on the thermostat LCD screen when the input is energized. Service , a back-lit flashing Service alarm will be displayed on the thermostat LCD screen when the input is energized. Fan lock , a back-lit flashing Fan lock alarm will be displayed on the thermostat LCD screen when the input is not energized. Used in conjunction with a local airflow sensor connected to the input. Locks out the thermostat heating and cooling action if no airflow is detected 10 seconds after the fan (G terminal) is energized. Open contact = no airflow Closed contacts = airflow present
DI 2	Digital input no. 2 configuration Default value = None	Same as above. It is possible to configure both inputs to have the same function.
MenuScro	Menu scroll Default value = On = Scroll active	Removes the scrolling display and only present the room temperature/humidity to the user. With this option enabled, no status is given of mode, schedule and outdoor temperature. On = Scroll active Off = Scroll not active

Installer Configuration Parameter Menu

Configuration parameters	Significance Default value	Adjustments						
lockout	Keypad lockout levels Default value = 0 No lock	0 = No lock 1 = Low level 2 = High level						
Level	Resume/Override scheduling	Permanent Occupied and Unoccupied Setpoints	Temporary setpoints using arrows	System mode setting	Fan mode setting	Schedules setting	Clock setting	Permanent hold
	Resume sched Y/N	RoomTemp set Y/N	Up key (▲) Down key (▼)	Sys mode set Y/N	Fan mode set Y/N	Schedule set Y/N	Clock set Y/N	Schedule hold Y/N
0	Yes access	Yes access	Yes access	Yes access	Yes access	Yes access	Yes access	Yes access
1	Yes access	No access	Yes access	No access	No access	No access	Yes access	No access
2	No access	No access	No access	No access	No access	No access	Yes access	No access
pwr del	Power-up delay Default value = 10 seconds	On initial power up of the thermostat (each time 24 Vac power supply is removed and re-applied) there is a delay before any operation is authorized (fan, cooling or heating). This can be used to sequence start up multiple units / thermostat in one location. 10 to 120 seconds						
Frost pr	Frost protection enabled Default value = Off On heat pump models the system mode will be forced to EMERGENCY mode if frost protection is activated	Off: no room frost protection On: room frost protection enabled in all system mode at: 42°F (5.6°C) Frost protection is enabled even in system Off mode Off or On						
heat max	Maximum heating setpoint limit Default value = 90°F (32°C)	Maximum occupied and unoccupied heating setpoint adjustment. Heating setpoint range is: 40 to 90°F (4.5 to 32.0°C)						
cool min	Minimum cooling setpoint limit Default value = 54°F (12°C)	Minimum occupied and unoccupied cooling setpoint adjustment. Cooling setpoint range is: 54 to 100°F (12.0 to 37.5°C)						
Pband	Proportional Band setting Default value 2 = 2.0°F (0.6°C)	Adjust the proportional band used by the thermostat PI control loop. Warning: Note that the default value of 2.0°F (1.1°C) gives satisfactory operation in most normal installation cases. The use of a superior proportional band different than the factory one is normally warranted in applications where the thermostat location is problematic and leads to unwanted cycling of the unit. A typical example is a wall mounted unit where the thermostat is installed between the return and supply air feeds and is directly influenced by the supply air stream of the unit.						
		Value	F scale Pband		C scale Pband			
		2	2 F		1.1 C			
		3	3 F		1.7 C			
		4	4 F		2.2 C			
		5	5 F		2.8 C			
		6	6 F		3.3 C			
		7	7 F		3.9 C			
8	8 F		4.4 C					

Installer Configuration Parameter Menu

Configuration parameters	Significance Default value	Adjustments
Anticycle	Minimum on/off operation time for stages Default value = 2 minutes Anti-short cycling can be set to 0 minutes for equipment that posses their own anti cycling timer. Do not use that value unless the equipment is equipped with such internal timer. Failure to do so can damage the equipment.	Minimum On/Off operation time of cooling and heating stages. Important: <i>Anti-short cycling can be set to 0 minutes for equipment that posses their own anti cycling timer. Do <u>not</u> use this value unless the equipment is equipped with such internal timer. Failure to do so can damage the equipment.</i> 0, 1, 2, 3, 4 and 5 minutes
Heat cph	Heating stages cycles per hour Default value = 4 C.P.H. For multi stage models, heat cph applies to W1 and W2 For heat pump models, heat cph applies to W1 only (Emergency heat)	Will set the maximum number of heating stage cycles per hour under normal control operation. It represents the maximum number of cycles that the equipment will turn ON and OFF in one hour. Note that a higher C.P.H will represent a higher accuracy of control at the expense of wearing mechanical components faster. 3, 4, 5, 6, 7 and 8 C.P.H.
cool cph	Cooling stages cycles per hour Default value = 4 C.P.H. For multi stage models, cool cph applies to Y1 and Y2 For heat pump models, cool cph applies to Y1 and Y2 in cooling and heating independently of the reversing valve position	Will set the maximum number of cooling stage cycles per hour under normal control operation. It represents the maximum number of cycles that the equipment will turned on and off in one hour. Note that a higher C.P.H will represent a higher accuracy of control at the expense of wearing mechanical components faster. 3 or 4 C.P.H.
Deadband	Minimum deadband Default value = 2.0°F (1.1°C)	Minimum deadband value between the heating and cooling setpoints. If modified, it will be applied only when any of the setpoints are modified. 2, 3 or 4°F (1.0 to 2.0°C)
fan cont	Fan control Default value = On For multi stage models, fan control applies to W1 and W2 For heat pump models, fan control applies to W1 only (Emergency heat)	Fan control in heating mode. When selecting On; the thermostat in all cases will always control the fan (terminal G). Valid for On or Auto fan mode When selecting Off; the fan (terminal G), when heating stages (terminals W1 and W2) are solicited, will not be energized. The fan in this case will be controlled by the equipment fan limit control. Valid only for Auto fan mode. On fan mode will leave the fan always on. On or Off
fan del	Fan delay Default value = Off	Fan delay extends fan operation by 60 seconds after the call for heating or cooling ends. Valid only for Auto fan mode. "On" fan mode will leave the fan always on. Off or On
ToccTime	Temporary occupancy time Default value = 3 hours	Temporary occupancy time with occupied mode setpoints when override function is enabled When the thermostat is in unoccupied mode, function is enabled with either the menu or DI1 or DI2 configured as remote override input. 0,1, 2, 3, 4, 5, 6, 7, 8, 9, 10, 11 and 12 hours
cal RS	Room air temperature sensor calibration Default value = 0.0°F or °C	Offset that can be added/subtracted to actual displayed room temperature ± 5.0°F (± 2.5°C)

Installer Configuration Parameter Menu

Configuration parameters	Significance Default value	Adjustments		
cal OS	Outside air temperature sensor calibration Default value = 0.0°F or °C	Offset that can be added/subtracted to actual displayed outside air temperature ± 5.0°F (± 2.5°C)		
H stage	Number of heating stages. Applicable to 2 stage models only Default value = 2 stages For heat pump models, H stage is limited to 1 stage only (W1 – Aux. Heat)	Will revert the operation of 2 stages thermostat to single stage operation only when the second heating step is not needed. 1 or 2 stages		
HP stage	Number of heat pump stages Default value = 2 stages	Will revert the operation of 2 stage thermostat to single stage operation only when the second compressor heating or cooling step is not needed. 1 or 2 stages		
H lock	Outside air temperature heating lockout Default value = 120°F (49°C)	Disables heating stage operation based on outdoor air temperature. Function will only be enabled if OS (outside air temperature sensor) is connected. From -15°F up to 120°F (-26°C up to 49°C)		
C lock	Outside air temperature mechanical cooling lockout. Default value = -40°F (-40°C)	Disables cooling stage operation based on outdoor air temperature. On economizer model, free cooling will not be disabled by this function. Function will only be enabled if OS (outside air temperature sensor) is connected. From -40°F up to 95°F (-40°C up to 35°C)		
Unocc TM	Unoccupied Timer value Default 0.5 hours	Time delay between the moment where the thermostat toggles from occupied to unoccupied after the last movement has been detected by the PIR. Range is: 0.5 to 24.0 hours in 0.5 hour increments		
aux cont	Auxiliary contact configuration Default value = N.O. normally open	This contact can be used to energize peripheral devices such as: lighting equipment, exhaust fans, economizers, etc. This contact will operate in parallel with the internal occupied/unoccupied schedule of the thermostat or the remote NSB contact if DI1 or DI2 is used. When the system is in OFF mode, the contact will remain in its unoccupied status independently of the occupied / unoccupied schedule.		
		Configured	Contact occupied status	Contact unoccupied status
		N.O.	Closed	Opened
		N.C.	Opened	Closed
high pb	High balance point Default value = 90°F (32.0°C) Function will only be enabled if OS (outside air temperature sensor) is connected.	In <i>Heating or Auto mode</i> , it is the outside air temperature value at which the auxiliary heat will be cut off. Above that value, only the heat pump will be used to maintain the heating setpoint 34 to 90°F (1.0 to 32.0°C)		
low pb	Low balance point Default value = -12°F (-24°C) Function will only be enabled if OS (outside air temperature sensor) is connected.	In <i>Heating, Cooling or Auto mode</i> , it is the outside air temperature value at which the heat pump operation will be cut off. Below that value, only the auxiliary heat will be used to maintain the heating setpoint -40 to 30°F (-40 to -1.0°C)		



Installer Configuration Parameter Menu

Configuration parameters	Significance Default value	Adjustments
Comf/eco	Comfort or economy mode Default value = Comfort	<p>Sets the operation and interaction mode of the heat pump with the auxiliary heat.</p> <p>Comfort mode. In <i>Heating mode</i>. If the heat pump is not able to satisfy the heating setpoint, the auxiliary heat will be energized to satisfy the same heating setpoint.</p> <p>Economy mode. In <i>Heating mode</i>. If the heat pump is not able to satisfy the heating setpoint, the auxiliary heat will be energized to satisfy only when the temperature has dropped 2.0°F (1.1°C) below the heating setpoint. Selecting economy mode will add a deadband between the heat pump and auxiliary heat in heating mode. The actual temperature maintained will be lower than the true heating setpoint to maximize the heat pump operation. When the outdoor air temperature drops below the <i>low balance point</i>, the deadband will be eliminated and the auxiliary heat will maintain the true heating setpoint alone.</p> <p>Economy mode. In <i>Emergency mode</i>. If <i>Emergency heat mode</i> is selected, the setpoint maintained, will be the heating setpoint.</p>
re valve	Reversing valve operation O/B Default value = O	Heat pump reversing valve operation O will energize the valve in cooling operation. B will energize the valve in heating operation O or B
comp/aux	Compressor/auxiliary interlock Default value = Off	<p>Sets the operation and interaction mode of the heat pump with the auxiliary heat.</p> <p>Interlock Off. In <i>Heating mode</i>. If the heat pump is not able to satisfy the heating setpoint, the auxiliary heat will be energized at the same time as the heat pump stage. Typically applies when the air handler heat pump coil is installed before the auxiliary heat. (all electric systems)</p> <p>Interlock On. In <i>Heating mode</i>. If the heat pump is not able to satisfy the heating setpoint, the auxiliary heat will be energized and the heat pump will be cut off. Typically applies when the air handler heat pump coil is installed after the auxiliary heat. (add on systems) There is a 2 minute delay to restart the heat pump, when the auxiliary heat is shut down</p> <p>Off or On</p>

Notes for heat pump models: When the outside air sensor is not connected or is shorted, the thermostat bypasses the heating / cooling lockouts and the low / high balance points. Also, when set in Emergency system mode, the heat pump model bypasses heating lockout and permits auxiliary heating whenever a heating demand occurs.



Troubleshooting Guide (All Models)

Symptom	Possible Cause	Corrective Action
No display on the thermostat	Absent or incorrect supply voltage	Check power supply voltage between C and RC to be from 19-30 Vac Check for tripped fuse or circuit breaker
	Overloaded power transformer	Verify that the transformer used is powerful enough (enough VA's) to supply all controlled devices including the thermostat
Keyboard menu does not access all functions	Keyboard locked	Change configuration parameter LOCKOUT to value "0" to access all levels of the menu
Temperature setpoints revert to original value after a certain time period	Temporary setpoint option selected	The thermostat needs to be in Permanent setpoint mode for the new setpoint to be kept and memory and used all the time Go to the Set temperature menu. The last prompt is setpoint type. Set it to Permanent setpoint
Thermostat will not call for heating	Wrong mode selected	Select heating mode
	Thermostat in Unoccupied mode	Select Occupied Hold in Schedule hold or Override to force the thermostat Occupied heating setpoint
	Anticycle delay active	Wait, the anticycling period will end and the equipment will start
	Heating setpoint is satisfied	Raise the Heating setpoint
	Heating lockout attained	Mode is locked out based on outside air temperature Change configuration parameter H Lock to value 120°F (49°C) to by-pass lockout
	Wiring error	Start the Fan by forcing the Fan ON mode Put a jumper across terminals RH and W1. The heating should come ON. If it does not, verify wiring and check if a jumper is required between RC and RH
Thermostat will not call for cooling	Wrong mode selected	Select cooling mode
	Thermostat in Unoccupied mode	Select Occupied Hold in Schedule hold or Override to force the thermostat Occupied cooling setpoint
	Anticycle delay active	Wait, the anticycling period will end and the equipment will start
	Cooling setpoint is satisfied	Lower the cooling setpoint
	Cooling lockout attained	Mode is locked out based on outside air temperature Change configuration parameter C Lock to value -40°F (-40°C) to by-pass lockout
	Wiring error	Start the Fan by forcing the Fan ON mode Put a jumper across terminals RC and Y1. The cooling should come ON. If it does not, verify wiring



Troubleshooting Guide (All Models)

Symptom	Possible Cause	Corrective Action
The thermostat will not turn on the fan	Wrong mode selected	Start the Fan by forcing the Fan ON mode
	Wiring error	Put a jumper across terminals RC and G. The fan should come ON. If it does not, verify wiring
Digital display shows missing digits or erratic segments	Defective display	Replace thermostat



Troubleshooting Guide

Symptom	Possible Cause	Corrective Action
Auxiliary heat does not operate	Wrong mode selected	Select emergency heat mode
	Thermostat in Unoccupied mode	Select Occupied Hold in Schedule hold or Override to force the thermostat Occupied heating setpoint
	Anticycle delay active	Wait, the anticycling period will end and the equipment will start
	Heating setpoint is satisfied	Raise the Heating setpoint
	High Balance point attained	Mode is locked out based on outside air temperature Change configuration parameter High BP to value 90°F (32°C) to by-pass lockout
	Heating lockout attained	Mode is locked out based on outside air temperature Change configuration parameter H Lock to value 120°F (49°C) to by-pass lockout
	Wiring error	Start the Fan by forcing the Fan ON mode Put a jumper across terminals RH and W1. The heating should come ON. If it does not, verify wiring and check if a jumper is required between RC and RH
Heat pump does not operate in heating mode	Wrong mode selected	Select heating mode
	Thermostat in Unoccupied mode	Select Occupied Hold in Schedule hold or Override to force the thermostat Occupied heating setpoint
	Anticycle delay active	Wait, the anticycling period will end and the equipment will start
	Heating setpoint is satisfied	Raise the Heating setpoint
	Low Balance point attained	Mode is locked out based on outside air temperature Change configuration parameter Low BP to value -12°F (-24°C) to by-pass lockout
	Heating lockout attained	Mode is locked out based on outside air temperature Change configuration parameter H Lock to value 120°F (49°C) to by-pass lockout
	Wiring error	Start the Fan by forcing the Fan ON mode Put a jumper across terminals RH and W1. The heating should come ON. If it does not, verify wiring and check if a jumper is required between RC and RH
	Wrong reversing valve configuration	Wrong selection of parameter Re Valve Select O will energize the valve in cooling operation. Valve is normally heat. Select B will energize the valve in heating operation. Valve is normally cool.



Specifications

Thermostat power requirements:	19-30 Vac 50 or 60 Hz; 2 VA (RC and C) Class 2 RC to RH jumper 2.0 Amps 48 VA maximum
Operating conditions:	32°F to 122°F (0°C to 50°C) 0% to 95% R.H. non-condensing
Storage conditions:	-22°F to 122°F (-30°C to 50°C) 0% to 95% R.H. non-condensing
Sensor:	Local 10 K NTC thermistor
Resolution:	± 0.2°F (± 0.1°C)
Control accuracy:	± 0.9°F (± 0.5° C) @ 70°F (21°C) typical calibrated
Occupied and unoccupied setpoint range cooling:	54 to 100°F (12.0 to 37.5°C)
Occupied and unoccupied setpoint range heating:	40°F to 90°F (4.5°C to 32°C)
Room and outdoor air temperature range	-40°F to 122°F (-40°C to 50°C)
Proportional band for room temperature control:	Factory set, heating and cooling at: 2.0°F (1.1°C)
Digital inputs:	Relay dry contact only across C terminal to DI1 or DI2
Contact output rating:	Each relay output: (Y1, Y2, G, W1, W2 and AU) 30 Vac, 1 Amp. maximum 30 Vac, 3 Amp. in-rush
Wire gauge	18 gauge maximum, 22 gauge recommended
Dimensions:	4.94 in. x 3.38 in. x 1.13 in.
Approximate shipping weight:	0.75 lb (0.34 kg)
Agency Approval all models:	UL: UL 873 (US) and CSA C22.2 No. 24 (Canada), File E27734 with CCN XAPX (US) and XAPX7 (Canada) Industry Canada: ICES-003 (Canada) FCC: Compliant to CFR 47, Part 15, Subpart B, Class A (US) CE: EMC Directive 89/336/EEC (European Union) C-Tick: AS/NZS CISPR 22 Compliant (Australia / New Zealand) Supplier Code Number N10696

Drawings and Dimensions

Figure 9. Thermostat dimensions

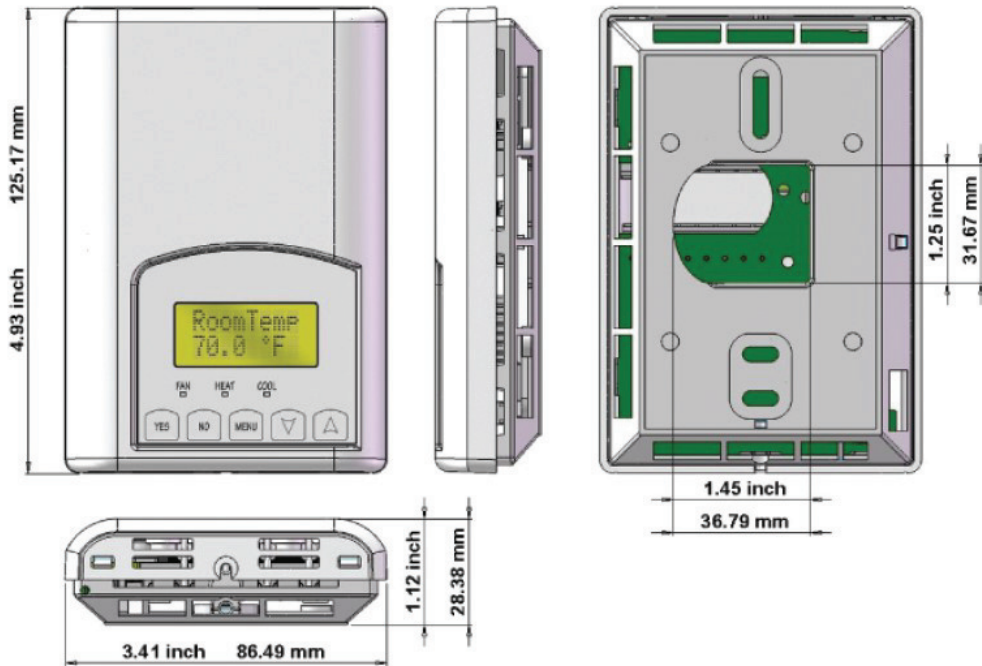

⚠ CAUTION

Use proper safety measures to protect system!

All Communicating RTU thermostats are for use as operating controls only and are not safety devices. These instruments have undergone rigorous tests and verifications prior to shipment to ensure proper and reliable operation in the field. Whenever a control failure could lead to personal injury and/or loss of property, it becomes the responsibility of the user / installer / electrical system designer to incorporate safety devices (such as relays, flow switch, thermal protections, etc.) and/or an alarm system to protect the entire system against such catastrophic failures. Tampering with the devices or misapplication of the device will void warranty.

Trane - by Trane Technologies (NYSE: TT), a global climate innovator - creates comfortable, energy efficient indoor environments for commercial and residential applications. For more information, please visit trane.com or tranetechnologies.com.

Trane has a policy of continuous product and product data improvement and reserves the right to change design and specifications without notice. We are committed to using environmentally conscious print practices.